

Type	Value
Max Weight	28kg / 61lb
IP Class	IP21
UL Type	Type I

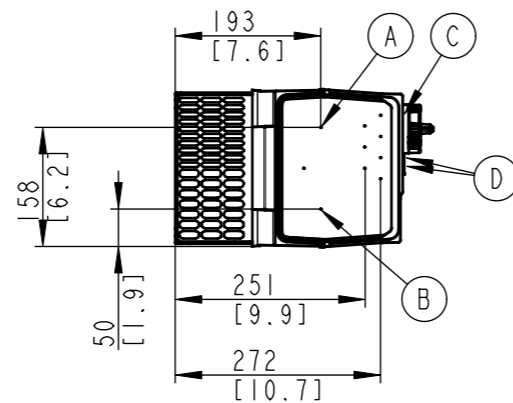

See page 2 for detail

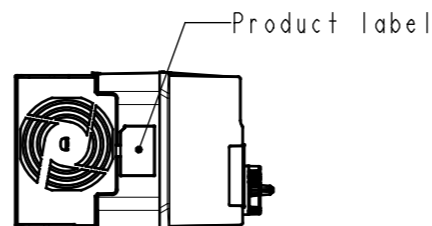
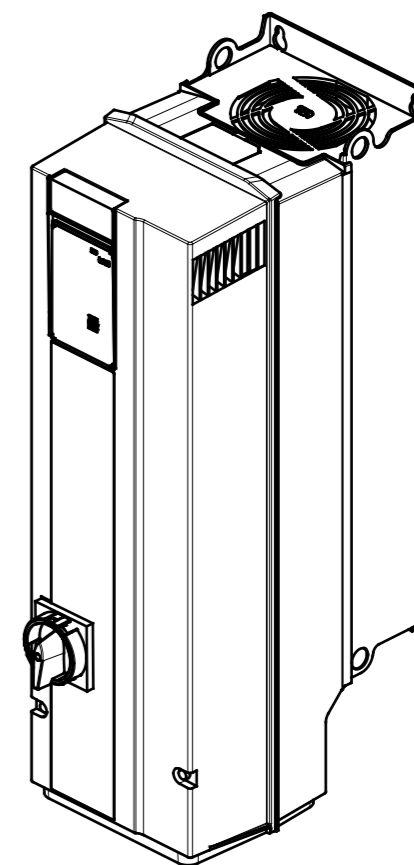
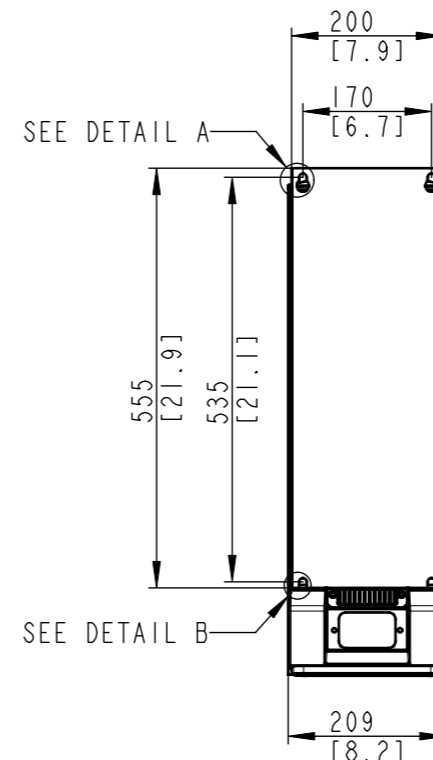
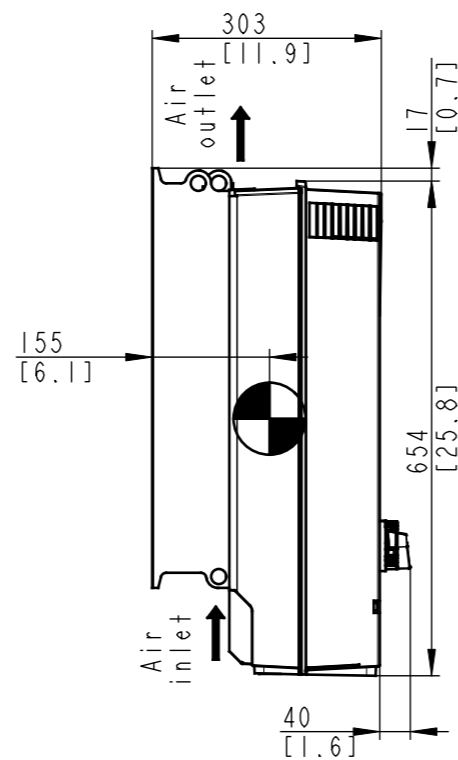
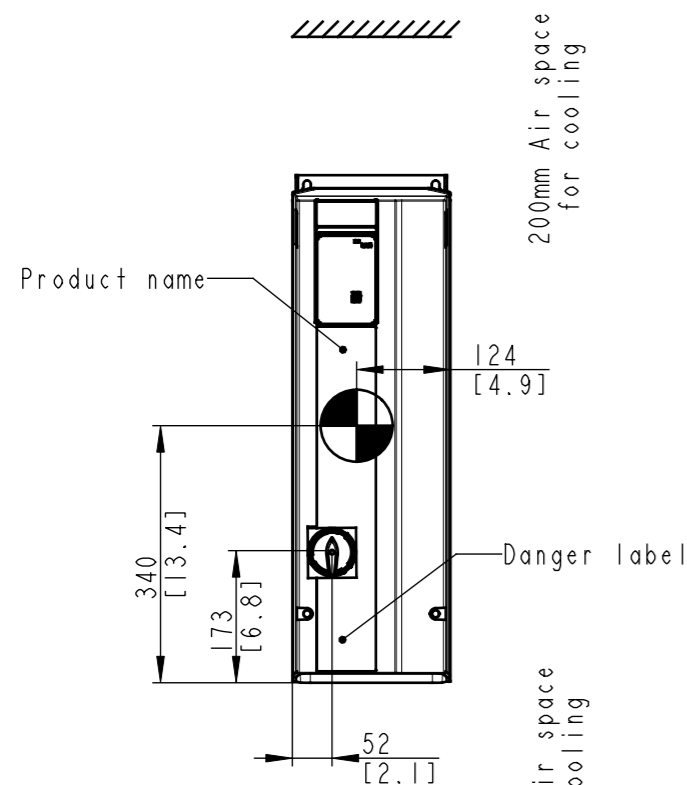
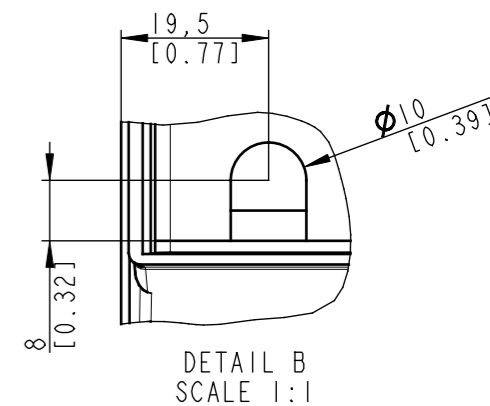
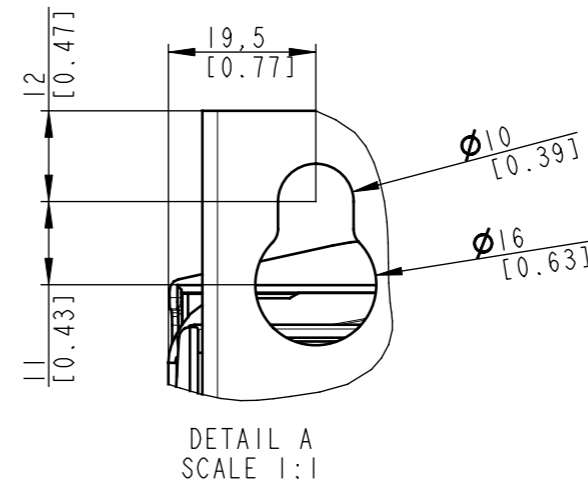

Position of connectors	
A	Line
B	Motor
C	Interface X0
D	Interface X1/X2

THIS DRAWING SHOWS THE MOST COMMON VERSION OF THIS PRODUCT VARIANT. SMALL DIFFERENCES MAY OCCUR DEPENDING ON THE FINAL PRODUCT CONFIGURATION.

CENTER OF GRAVITY: FOR REFERENCE ONLY, THE PRODUCT CONFIGURATION MAY INFLUENCE THE CG IN ALL THREE AXES.

UNLESS OTHERWISE SPECIFIED THE TOLERANCE IS ± 0.1 MM [0.4 INCH]. ALL DIMENSIONS ARE IN MILLIMETERS [INCH].			FIRST ANGLE PROJECTION	SCALE 1:10	DRAWING SIZE A3	MATERIAL -	
						FINISH -	
					DESCRIPTION		
					MCAD FK06 IP21 WITH DISCONNECT		
CHANGED							
DESIGNED	Kishore	2021-10-07					
CHECKED							
PROPERTY OF DANFOSS A/S NORDBOG, DENMARK. TWO OR THREE DIMENSIONAL REPRODUCTION OF CONTENTS TO BE AUTHORIZED BY DANFOSS A/S.						DRAWING NUMBER	REV
						MCAD FK06 IP21 WITH DISCONNECT	
						MODEL	SHEET
						MCAD FK06 IP21 WITH DISCONNECT	1 OF 2

SECTION A-A
LINE TERMINALS

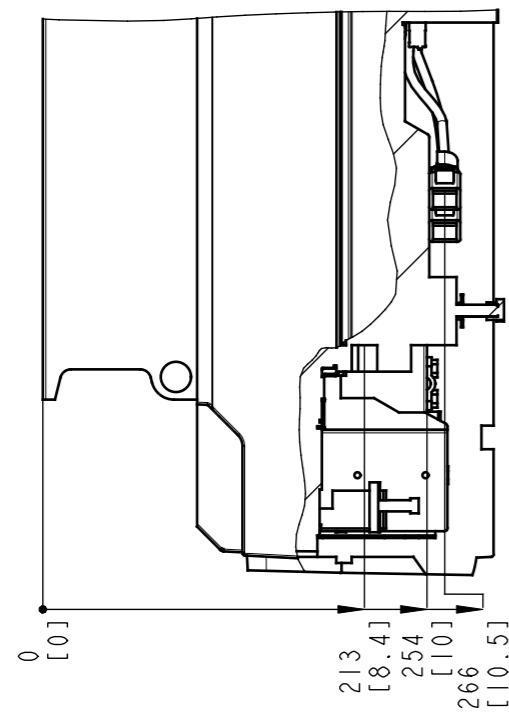

1:5

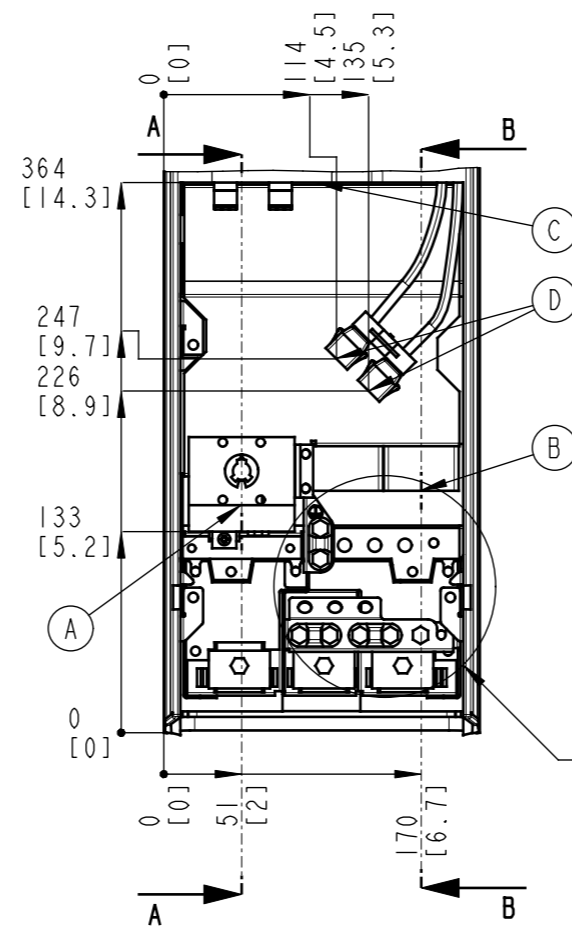

Detailed earthing information SEE DETAIL C

SECTION B-B
MOTOR TERMINALS

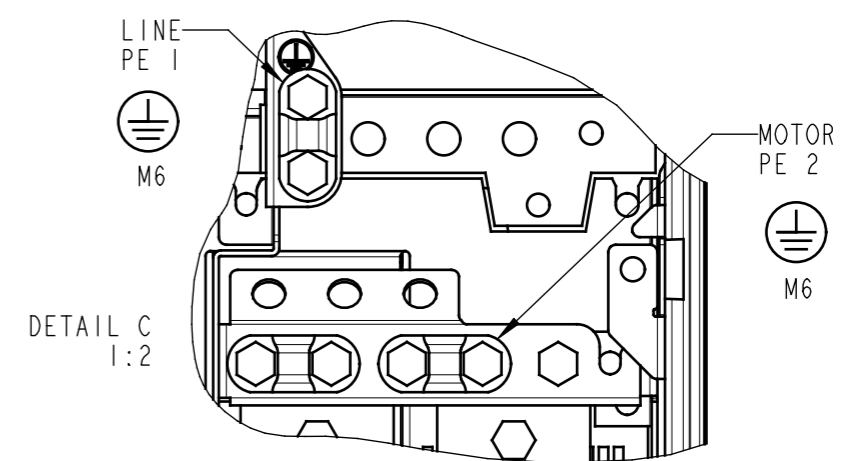
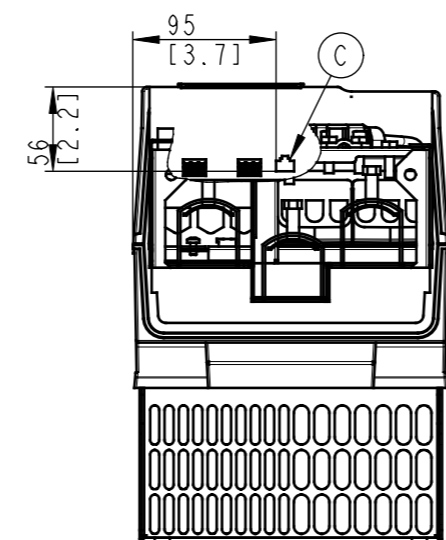
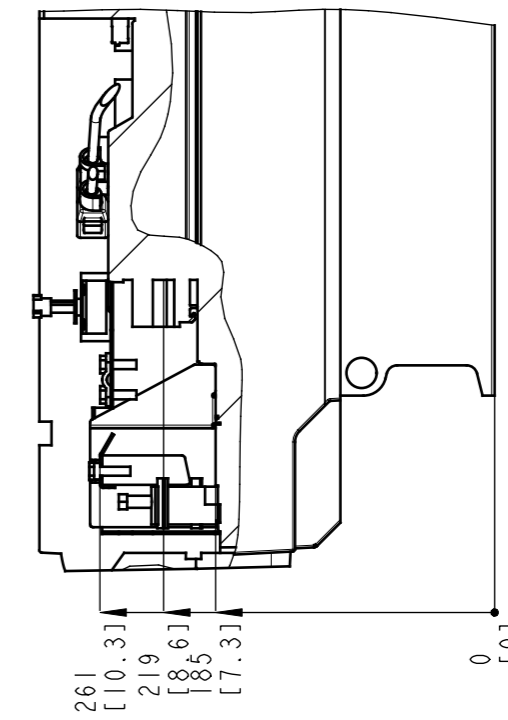

EARTHING INFORMATION

Position of connectors	
A	Line
B	Motor
C	Interface X0
D	Interface X1/X2

THIS DRAWING SHOWS THE MOST COMMON VERSION OF THIS PRODUCT VARIANT.
SMALL DIFFERENCES MAY OCCUR DEPENDING ON THE FINAL PRODUCT CONFIGURATION.

PROPERTY OF DANFOSS A/S NORDBOG, DENMARK. TWO OR THREE DIMENSIONAL REPRODUCTION OF CONTENTS TO BE AUTHORIZED BY DANFOSS A/S.

DRAWING NUMBER	MCAD FK06 1P21 WITH DISCONNECT	REV
MODEL	MCAD FK06 1P21 WITH DISCONNECT	SHEET
		2 OF 2