

Type	Value
Max Weight	38kg/84lb
IP Class	IP20
UL Class	Open

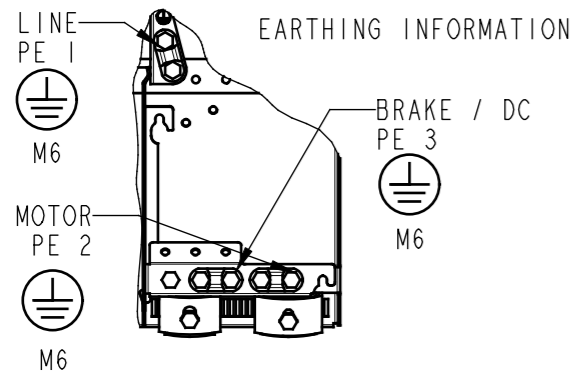

DETAIL C
SCALE 1:5

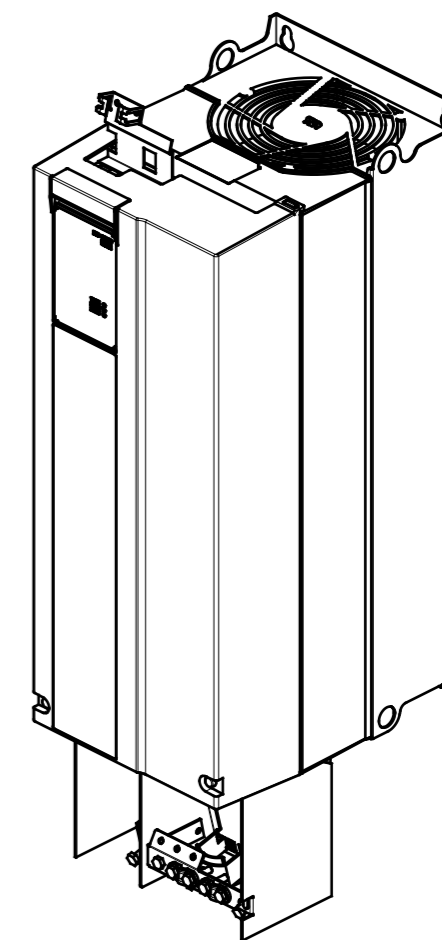
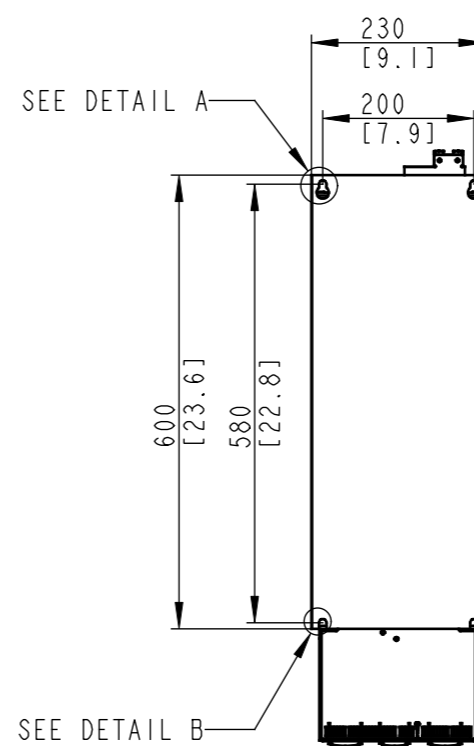
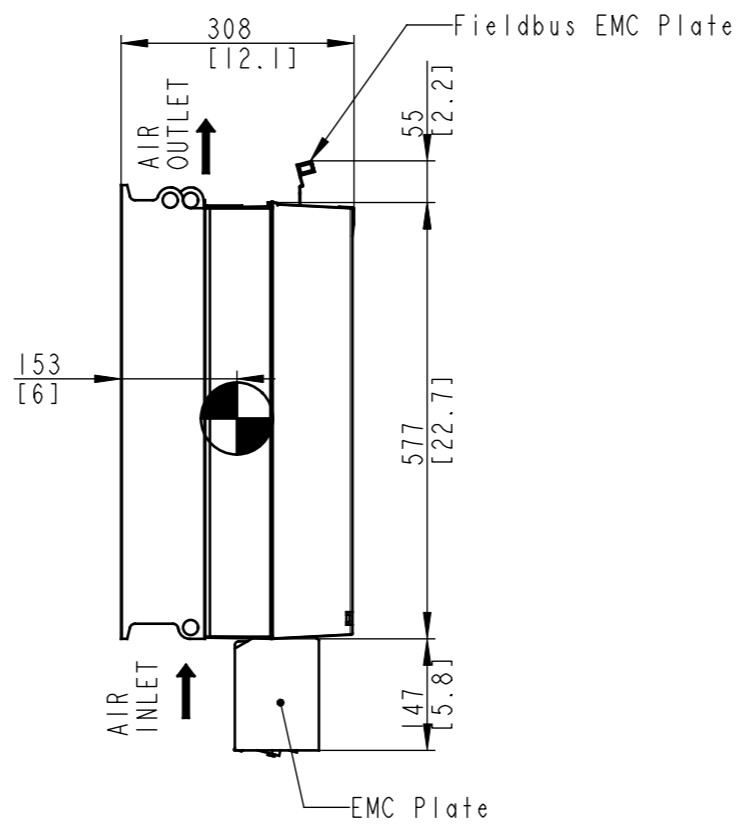
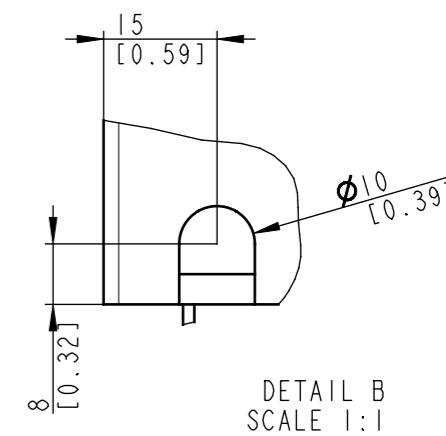
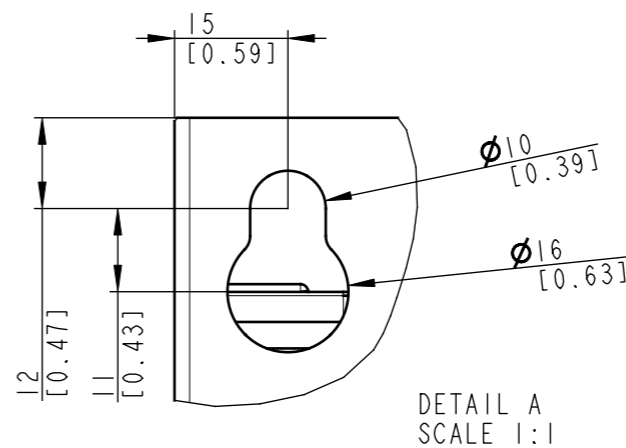
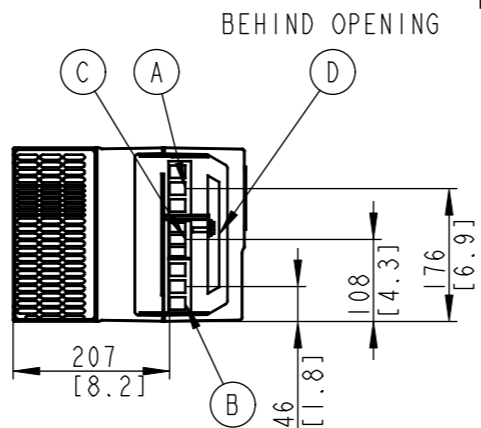
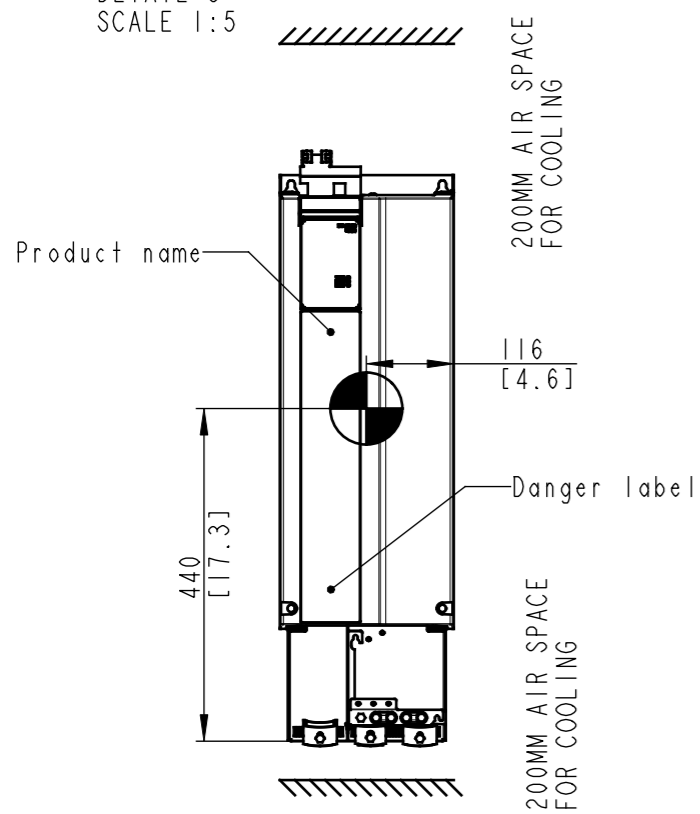

Position of connectors	
A	Line
B	Motor
C	Brake / DC
D	Interface X0
E	Interface X1/X2

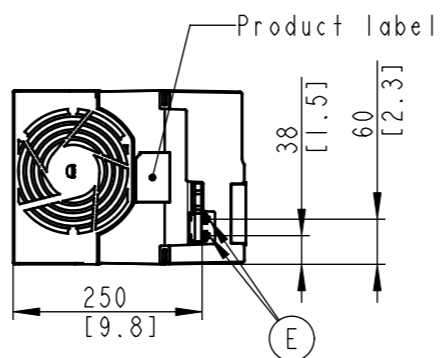

THIS DRAWING SHOWS THE MOST COMMON VERSION OF THIS PRODUCT VARIANT.
SMALL DIFFERENCES MAY OCCUR DEPENDING ON THE FINAL PRODUCT CONFIGURATION.

CENTER OF GRAVITY:
FOR REFERENCE ONLY, THE PRODUCT CONFIGURATION MAY INFLUENCE THE CG IN ALL THREE AXES.

UNLESS OTHERWISE SPECIFIED THE TOLERANCE IS ± 0.4 INCH. ALL DIMENSIONS ARE IN MILLIMETERS [INCH]		FIRST ANGLE PROJECTION	SCALE 1:10	DRAWING SIZE A3	MATERIAL
					FINISH
					DESCRIPTION
					MCAD_FA07_IP20
CHANGED					DRAWING NUMBER
DESIGNED	Danfoss 2020-12-15				MCAD_FA07_IP20
CHECKED					REV
PROPERTY OF DANFOSS A/S NORDBOG, DENMARK. TWO OR THREE DIMENSIONAL REPRODUCTION OF CONTENTS TO BE AUTHORIZED BY DANFOSS A/S.		MODEL	MCAD_FA07_IP20	SHEET	1 OF 1