



Soft-Starter

SSW-08

User Manual



LED FAULT	LED READY	FAULT DESCRIPTION
1x	OFF	FREQUENCY RANGE
1x	ON	OVERTEMPERATURE
2x	OFF	UNDERVOLTAGE
2x	ON	START TIMEOUT
3x	OFF	BY-PASS OPEN
4x	OFF	OVERCURRENT BEFORE BY-PASS
6x	OFF	SCR OR BY-PASS SHORT CIRCUIT

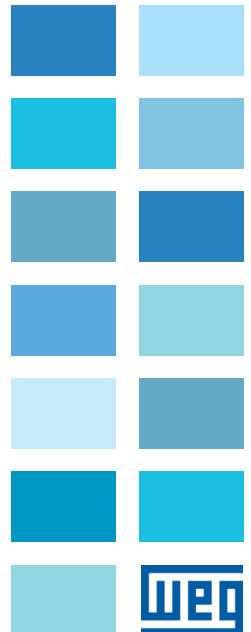



Soft-Starter User Manual

Series/Série: SSW-08

English / Español / Português

Document/Documento: 10000008521 / 09

**Please take this page out when
unpacking the product**



10666272



Soft-Starter User Manual

Series/Série: SSW-08

Document/Documento: 10000008521 / 09

Date/Fecha/Data: 09/2024

The information below describes the revisions in this manual.

Revision	Description	Chapter
1	First Edition	-
2	Size 4 included	-
3	Revision after the size 4 UL certification. Changed: item 3.2; figure 3.4; figure 3.5; item 3.2.4.1; 3.2.4.2; 3.2.7; 3.3; 5.2.2; E77 in the table 6.1; table 8.1. Included new functions of software version V1.4x.	3, 4, 5, 6, 8
4	General revision	-
5	Change in table 7.1	7
6	E19 Included in the table 6.1	6
7	Changes in item 3.2.4	3
8	Changes in item 3.2.7	3
9	General revision	3

La información abajo describe las revisiones ocurridas em este manual.

Revisión	Descripción	Capítulo
1	Primer Edición	-
2	Inclusión Mecánica 4	-
3	Corrección luego de la certificación UL de la mecánica 4. Modificado: ítem 3.2; figura 3.4; figura 3.5; ítem 3.2.4.1; 3.2.4.2; 3.2.7; 3.3; 5.2.2; E77 en la tabla 6.1; tabla 8.1. Inclusión de las nuevas funciones de la version de software V1.4x.	3, 4, 5, 6, 8
4	Revisión general	-
5	Alteración en la tabla 7.1	7
6	Inclusión E19 en la tabla 6.1	6
7	Modificaciones en el ítem 3.2.4	3
8	Modificaciones en el ítem 3.2.7	3
9	Revisión general	3

As informações abaixo descrevem as revisões ocorridas neste manual.

Revisão	Descrição	Capítulo
1	Primeira Edição	-
2	Inclusão da mecânica 4	-
3	Correção depois da certificação UL da mecânica 4. Alterado: ítem 3.2; figura 3.4; figura 3.5; ítem 3.2.4.1; 3.2.4.2; 3.2.7; 3.3; 5.2.2; E77 na tabela 6.1; tabela 8.1. Inclusão das novas funções da versão de software V1.4x.	3, 4, 5, 6, 8
4	Revisão geral	-
5	Alteração na tabela 7.1	7
6	Inclusão de E19 na tabela 6.1	6
7	Alterações no ítem 3.2.4	3
8	Alterações no ítem 3.2.7	3
9	Revisão geral	3

1. SAFETY INSTRUCTIONS	
1.1 SAFETY NOTICES IN THE MANUAL	1
1.2 SAFETY NOTICES ON THE PRODUCT	1
1.3 PRELIMINARY RECOMMENDATIONS.....	1
2. GENERAL INFORMATION	
2.1 ABOUT THIS MANUAL	3
2.2 ABOUT THE SOFT-STARTER SSW-08	3
2.3 SOFT-STARTER SSW-08 IDENTIFICATION PLATE	5
2.4 RECEIVING AND STORAGE	7
3. INSTALLATION AND CONNECTION	
3.1 MECHANICAL INSTALLATION	8
3.1.1 Environmental Conditions.....	8
3.1.2 Soft-Starter SSW-08 Dimensions	8
3.1.3 Mounting Specifications	9
3.1.3.1 Mounting Inside a Panel.....	10
3.1.3.2 Mounting on Surface.....	11
3.2 ELECTRICAL INSTALLATION	11
3.2.1 Power Terminals	12
3.2.2 Location of the Grounding, Control and Power Connections	13
3.2.3 Recommended Power and Grounding Cables	13
3.2.4 Power Supply Connection to the Soft-Starter SSW-08.....	14
3.2.4.1 Short Circuit Capacity, Fuses, Circuit Breaker – UL	15
3.2.4.2 Input Circuit Breakers and Fuses – IEC	15
3.2.4.3 Control Fuse	16
3.2.5 Soft-Starter SSW-08 Connection to the Motor	17
3.2.5.1 Standard Three-Wire Connection	18
3.2.6 Grounding Connections	18
3.2.7 Control and Signal Connections	20
3.3 RECOMMENDED SET-UPS	20
3.3.1 Recommended Set-up with Command via Two-wire Digital Inputs and Isolation Contactor.....	21
3.3.2 Recommended Set-up with Command via Three-wire Digital Inputs and Circuit-Breaker	22
3.3.3 Recommended Set-up with Command via Two-wire Digital Inputs and Direction of Rotation	23
3.3.4 Recommended Set-up with Command via Two-wires Digital Inputs and DC-Braking.....	24
3.3.5 Symbols.....	25
4. SETTING THE SSW-08	
4.1 CONTROL TYPE SETTING	26
4.2 KICK START	27
4.3 INITIAL VOLTAGE SETTING.....	27
4.4 CURRENT LIMIT SETTING	28
4.5 ACCELERATION RAMP TIME SETTING.....	29
4.6 DECELERATION RAMP TIME SETTING.....	29
4.7 MOTOR CURRENT SETTING.....	30
4.8 MOTOR ELECTRONIC OVERLOAD PROTECTION.....	31
4.9 RESET	33
4.10 DI2 DIGITAL INPUT SETTING	33
4.11 OUTPUT RELAY OPERATION	34
4.12 RELAY OUTPUT RL1 PROGRAMMING	34

5. PROGRAMMING INFORMATION AND SUGGESTIONS	
5.1 APPLICATIONS AND PROGRAMMING.....	35
5.1.1 Voltage Ramp Starting	36
5.1.2 Current Limit Starting	37
5.1.3 Starting with Pump Control (P202 = 2).....	37
5.1.4 Programming the control type in pump control	39
5.2 PROTECTIONS AND PROGRAMMING.....	39
5.2.1 Suggestion on How to Program the Thermal Class.....	39
5.2.2 Service Factor.....	42
6. SOLUTION AND TROUBLESHOOTING	
6.1 FAULTS AND POSSIBLE CAUSES.....	44
6.2 TROUBLESHOOTING	47
6.3 PREVENTIVE MAINTENANCE	48
7. OPTIONS AND ACCESSORIES	
7.1 IP20 KIT	49
8. TECHNICAL CHARACTERISTICS	
8.1 NOMINAL POWERS AND CURRENTS ACCORDING TO UL508	50
8.2 NOMINAL POWERS AND CURRENTS FOR STANDARD IP55, IV POLE WEG MOTOR.....	50
8.3 POWER DATA	51
8.4 ELECTRONICS AND PROGRAMMING DATA.....	51

1. SAFETY INSTRUCTIONS

This Manual contains the necessary information for the correct use of the Soft-Starter SSW-08. It was written to be used by qualified personnel with suitable training or technical qualifications to operate this type of equipment.

1.1 SAFETY NOTICES IN THE MANUAL

The following safety notices will be used in the text.



DANGER!

Failure to observe the recommended procedures may lead to serious or fatal injuries and considerable material damage.



ATTENTION!

Failure to observe the recommended procedures in this notice may lead to material damage.



NOTE!

Important information for the correct understanding and good function of the product.

1.2 SAFETY NOTICES ON THE PRODUCT

The following symbols may be attached to the product as a safety notice.



High Voltages.



**Components are sensitive to electrostatic discharge.
Do not touch them.**



Mandatory connection to ground protection (PE).

1.3 PRELIMINARY RECOMMENDATIONS



DANGER!

Only personnel with suitable qualification and familiar with the Soft-Starter SSW-08 and associated equipment should plan or implement the installation, start-up, operation and maintenance of this equipment.

These personnel must follow all safety instructions in this manual and/ or defined by local regulations.

Failure to follow these safety instructions may result in personnel injury and/or equipment damage.

1



NOTE!

In this Manual, qualified personnel are those trained to:

1. Install, ground, power-up, and operate the Soft-Starter SSW-08 according to this manual and the required safety procedures;
2. Use protection equipment according to established regulations;
3. Give First Aid.



DANGER!

Always disconnect the general power supply before touching any electrical component associated to the Soft-Starter SSW-08.

High voltage may be present even after the power supply is disconnected. Wait at least 3 minutes for the total discharge of the capacitors.

Always connect the equipment's heatsink to the protection ground (PE), at the proper connection point.



ATTENTION!

All electronic boards have components that are sensitive to electrostatic discharges. Do not touch these components or connectors directly.

If necessary, first touch the grounded metallic heatsink or use a suitable grounded wrist strap.

**Do not apply any high voltage test on the Soft-Starter SSW-08!
If necessary, contact the manufacturer.**



NOTE!

Soft-Starters SSW-08 may interfere with other electronic equipment. Follow the measures in Chapter 3 to reduce these effects.



NOTE!

Read this manual completely before installing or operating the Soft-Starter SSW-08.

2. GENERAL INFORMATION

2.1 ABOUT THIS MANUAL

This manual presents the Soft-Starter installation, how to start it up, its main technical characteristics and how to identify and correct the most common problems. The manuals listed next must be consulted in order to get more information regarding the functions, accessories and working conditions:

- Programming Manual, with a detailed description of the parameters and its functions;
- RS232 / RS485 Communication Manual.

These manuals are supplied in electronic format on the CD-ROM that accompanies the Soft-Starter, or can be obtained at WEG's web site: <http://www.weg.net>.

2.2 ABOUT THE SOFT-STARTER SSW-08

The Soft-Starter SSW-08 is a high performance product with 2 phases controlled that permits the start control of the three phase AC induction motors. Thus, it prevents mechanical shocks on the load and current peaks in the supply line.

The SSW-08 electronic Soft-Starter has been designed to drive three-phase induction motors applied to light duty loads, such as centrifugal pumps, small fans and screw compressors. If the Soft-Starter shall be applied on heavy duty loads, please contact WEG.

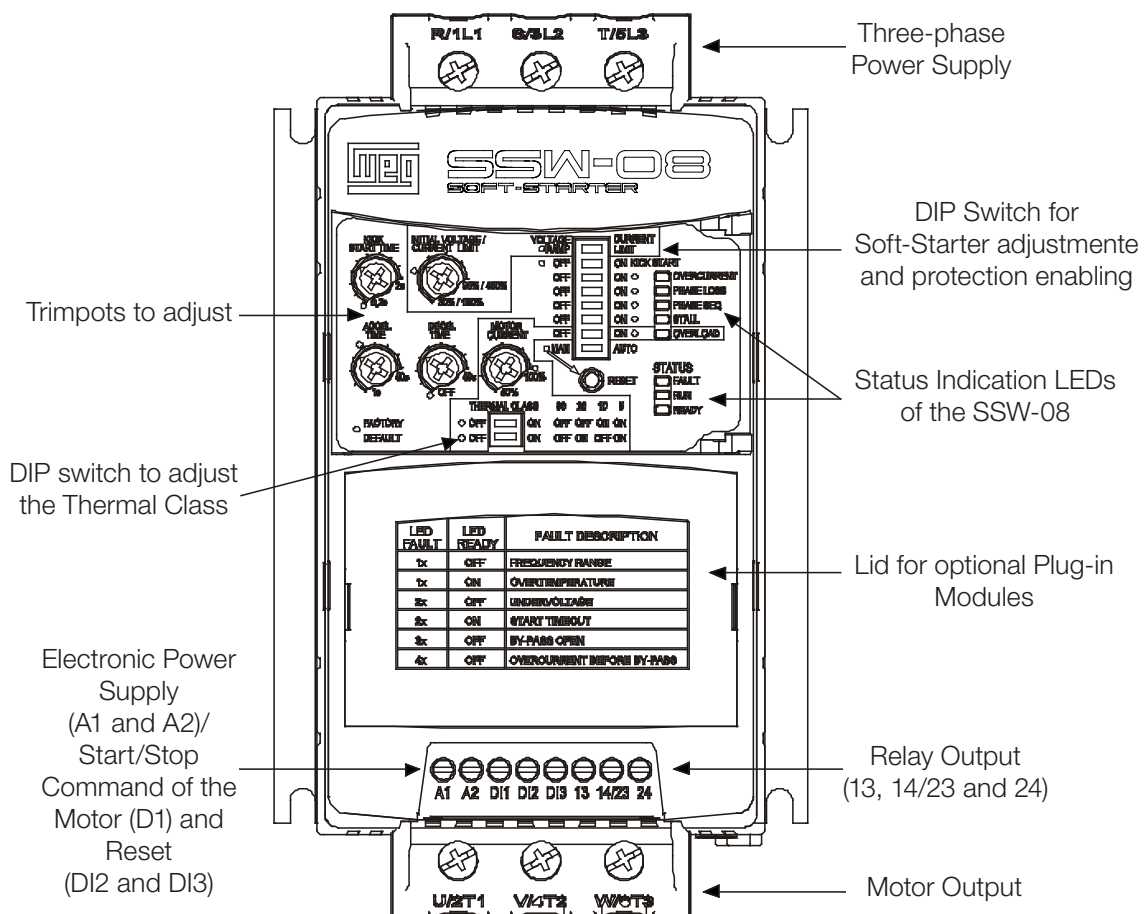

Figure 2.1: Frontal view of the SSW-08

2

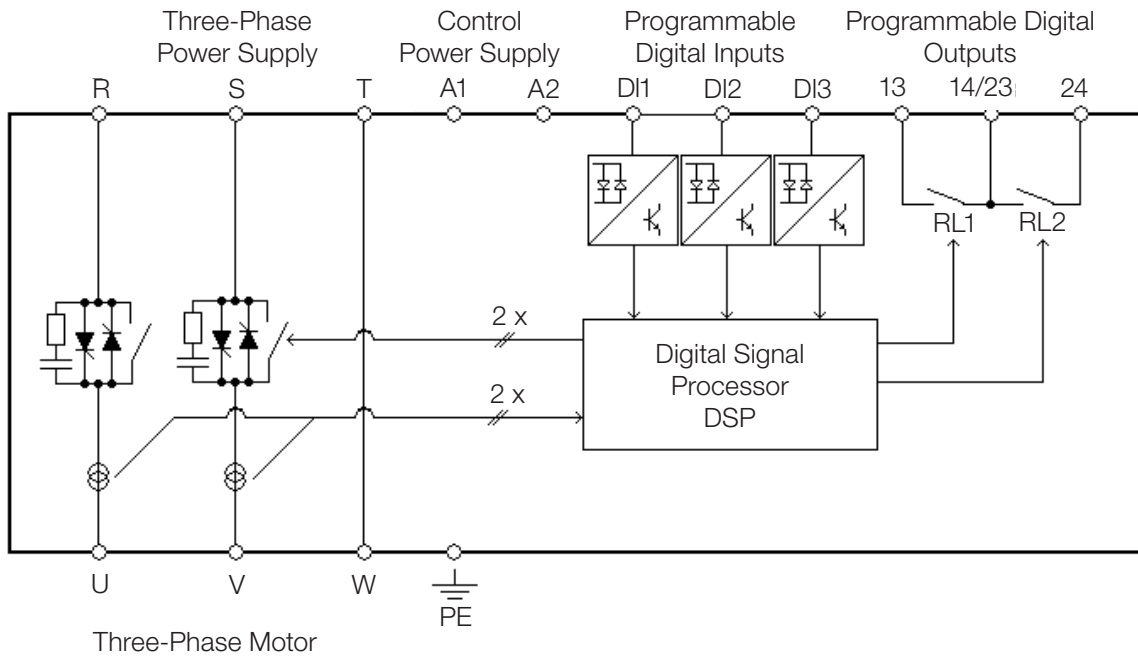

Figure 2.2.1: Soft-Starter SSW-08 size 1,2 and 3 block diagram

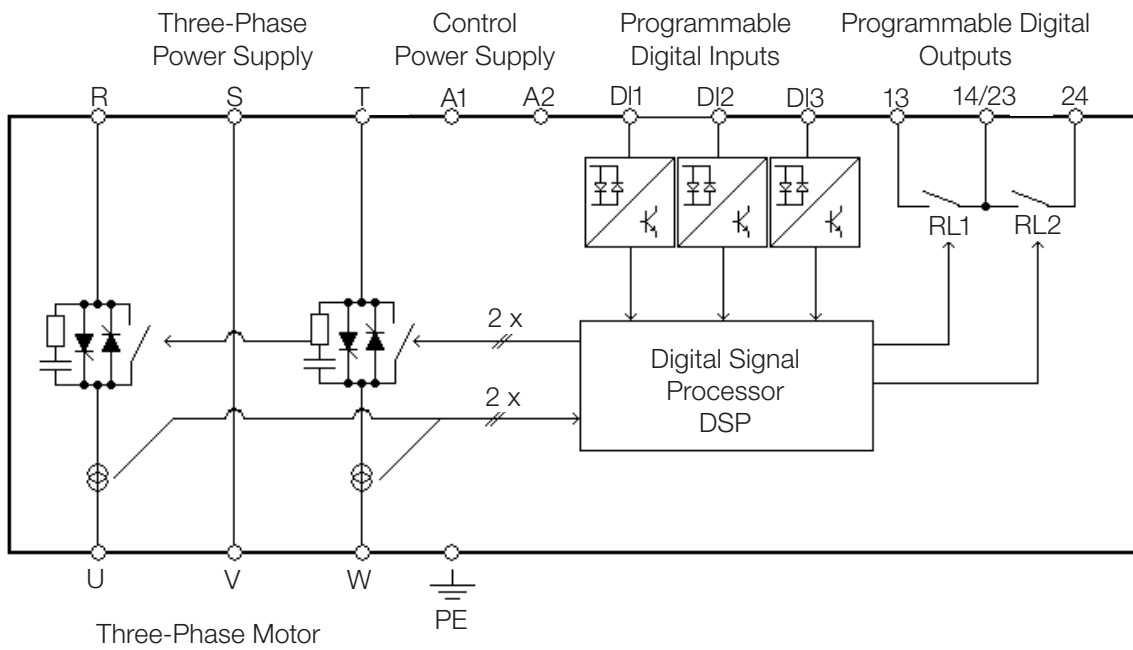

Figure 2.2.2: Soft-Starter SSW-08 Size 4 block diagram

2.3 SOFT-STARTER SSW-08 IDENTIFICATION PLATE

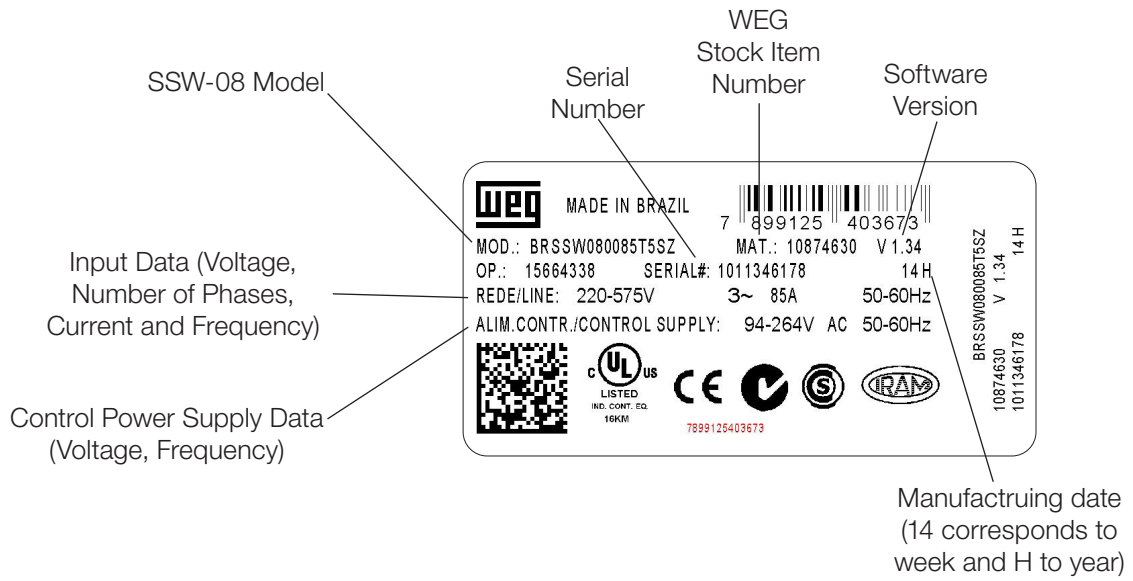

Figure 2.3: Soft-Starter SSW-08 identification plate

Position of the Identification Plate on the Soft-Starter SSW-08:

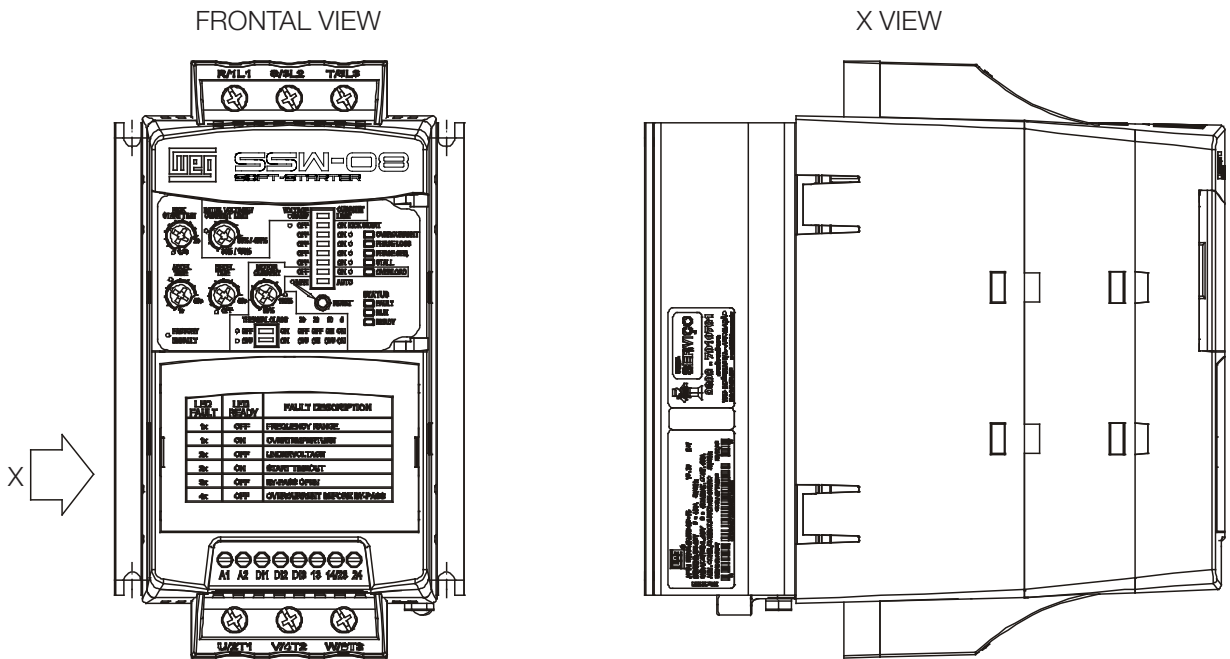

Figure 2.4: Detail of the Soft-Starter SSW-08 identification plate

HOW TO SPECIFY THE SSW-08 MODEL:

EX	SSW08	0017	T	5	S	---	---	Z	
Market/Manual BR = Brazil EX = Export	WEG Soft-Starter Series SSW-08	SSW-08 Nominal Current 0017 = 17 A 0024 = 24 A 0030 = 30 A 0045 = 45 A 0061 = 61 A 0085 = 85 A 0130 = 130 A 0171 = 171 A 0200 = 200 A 0255 = 255 A 0312 = 312 A 0365 = 365 A 0412 = 412 A	Three-Phase Power Supply	220-575 Vac	Optional: S = Standard O = with Optional	Degree of Protection Blank = Standard IP=IP20 ⁽¹⁾	Special Hardware Blank = Standard H1=Electronics supply: 110 to 130 Vac ⁽²⁾ H2= Electronics supply: 208 to 240 Vac ⁽²⁾	Special Software Blank = Standard	End of Code

⁽¹⁾ Only for models 130 A to 412 A.

⁽²⁾ Only for the 255 to 412A models.

REMARQUE!

The option field (S or O) defines if the Soft-Starter SSW-08 will be a standard version or if it will include any optional. If standard, the code ends here.

Always put the letter Z at the end. For example:

EXSSW080017T5SZ = Standard Soft-Starter SSW-08 with 17 A and 220 V to 575 V to three-phase input with the User's Guide in English, Spanish and Portuguese.

If there is any optional, the fields must be filled out in the correct sequence until the code is completed with the letter Z.

The standard product as defined by this code is described as:

- Degree of Protection: IP20 from 17 A to 85 A and IP00 from 130 A to 412 A.

2.4 RECEIVING AND STORAGE

The Soft-Starter SSW-08 is supplied in a cardboard box. On the outside of the package there is an identification plate which is identical to the one placed on the Soft-Starter SSW-08.

To open the package:

- 1- Put it on a table;
- 2- Open the package;
- 3- Take out the Soft-Starter.

Check if:

- The Identification plate of the Soft-Starter SSW-08 matches the model purchased;
- Damage has occurred during transport. If so, contact the carrier immediately.
- If the Soft-Starter SSW-08 is not installed immediately, store it in its package in a clean and dry place with temperature between -25 °C (-13 °F) and 65 °C (149 °F). 1 hour at -40 °C (-40 °F) is permitted.

Table 2.1: Dimensions of the package in mm (in)

SSW-08 Model	Height H mm (in)	Width L mm (in)	Depth P mm (in)	Volume cm ³ (in ³)	Weight kg (lb)
17 A 24 A 30 A	221 (8.70)	180 (7.09)	145 (5.71)	5768 (352.2)	1.65 (3.64)
45 A 61 A 85 A	260 (10.24)	198 (7.80)	245 (9.65)	12613 (770.8)	3.82 (8.42)
130 A 171 A 200 A	356 (14.02)	273 (10.75)	295 (11.61)	28670 (1750)	8.36 (18.43)
255 A 312 A 365 A 412 A	415 (16.34)	265 (10.43)	320 (12.6)	35192 (2147)	10.5 (23.2)

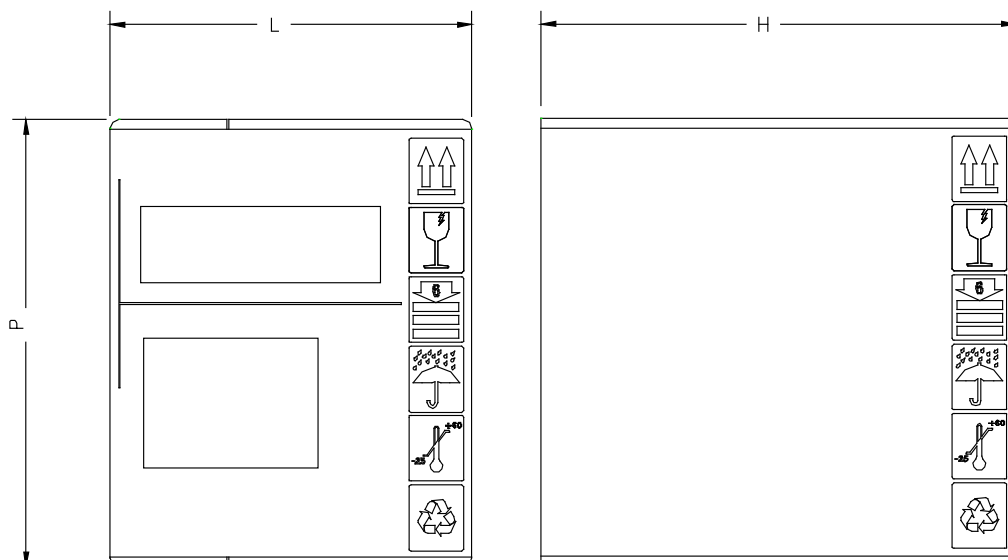

Figure 2.5: Dimensions of the package

3. INSTALLATION AND CONNECTION

This chapter describes the procedures for the electrical and mechanical installation of the Soft-Starter SSW-08. The guidelines and suggestions must be followed for the correct operation of the Soft-Starter SSW-08.

3.1 MECHANICAL INSTALLATION

3.1.1 Environmental Conditions

3

The location of the Soft-Starters SSW-08 is an important factor to assure the correct operation and high product reliability.

Avoid:

- Direct exposure to sunlight, rain, high moisture and sea air ;
- Exposure to explosive or corrosive gases and liquids;
- Exposure to excessive vibration, dust or any metallic and/or oil particles in the air.

Allowed Environmental Conditions:

- Surrounding air Temperature: 0 °C to 55 °C (32 °F to 131 °F) - nominal conditions.
- Relative air moisture: 5 % to 90 %, with no-condensation.
- Maximum altitude: 1,000 m (3,300 ft) above sea level - nominal conditions. From, 1,000 m to 4,000 m (3,300 ft to 13,200 ft) above sea level – current reduction of 1 % for each 100 m (330 ft) above 1,000 m (3,300 ft).
- Pollution degree: 2 (according to the UL508).
Normally, only non conductive pollution. Condensation must not cause conduction in the particles in the air.

3.1.2 Soft-Starter SSW-08 Dimensions

The external dimensions and mounting holes are shown in figure 3.1 and table 3.1 below.

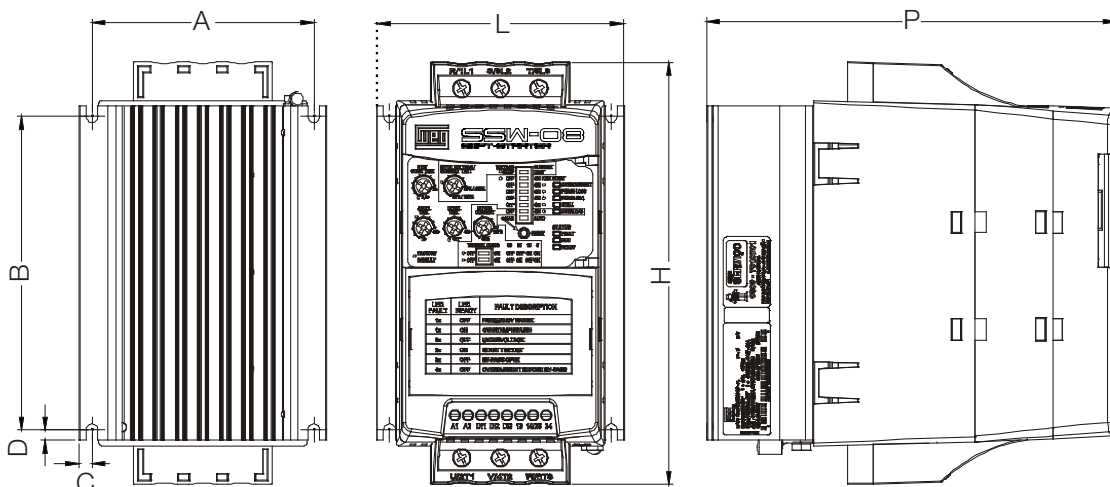

Figure 3.1: SW-08 dimensions

Table 3.1: Installation data with dimensions in mm (in)

SSW-08 Model	Height H mm (in)	Width L mm (in)	Depth P mm (in)	A mm (in)	B mm (in)	C mm (in)	D mm (in)	Mountin Screw	Weight kg (lb)	Degree of Protection
17 A 24 A 30 A	162 (6.38)	95 (3.74)	157 (6.18)	85 (3.35)	120 (4.72)	5 (0.20)	4 (0.16)	M4	1.3 (2.9)	IP20
45 A 61 A 85 A	208 (8.19)	144 (5.67)	203 (7.99)	132 (5.2)	148 (5.83)	6 (0.24)	3.4 (0.13)	M4	3.3 (7.28)	IP20
130 A 171 A 200 A	276 (10.9)	223 (8.78)	220 (8.66)	208 (8.19)	210 (8.27)	7.5 (0.3)	5 (0.2)	M5	7.6 (16.8)	IP00 *
255 A 312 A 365 A 412 A	331 (13.0)	227 (8.94)	242 (9.53)	200 (7.87)	280 (11.0)	15 (0.59)	9 (0.35)	M8	9.2 (20.32)	IP00 *

* IP20 with optional.

3.1.3 Mounting Specifications

To install the Soft-Starter SSW-08 leave at least the free spaces surrounding the Soft-Starter as in figure 3.2 below. The dimensions of these free spaces are described in table 3.2.

Table 3.2: Recommended free spaces

SSW-08 Model	A mm (in)	B mm (in)	C mm (in)
17 A 24 A 30 A	50 (2)	50 (2)	30 (1.2)
45 A 61 A 85 A	80 (3.2)	80 (3.2)	30 (1.2)
130 A 171 A 200 A	100 (4)	100 (4)	30 (1.2)
255 A 312 A 365 A 412 A	150 (6)	150 (6)	30 (1.2)

Install the Soft-Starter SSW-08 in the vertical position according to the following recommendations:

- 1) Install on a reasonably flat surface;
- 2) Do not put heat sensitive components immediately above the Soft-Starter SSW-08.



ATTENTION!

If a Soft-Starter SSW-08 is installed on top of another use the minimum distance A + B and diverge from the top Soft-Starter the hot air that comes from the one beneath it.



ATTENTION!

Independent conduits or cable trays must be planned for physic separation of signal, control and power cables. (Refer to item 3.2 Electric Installation).

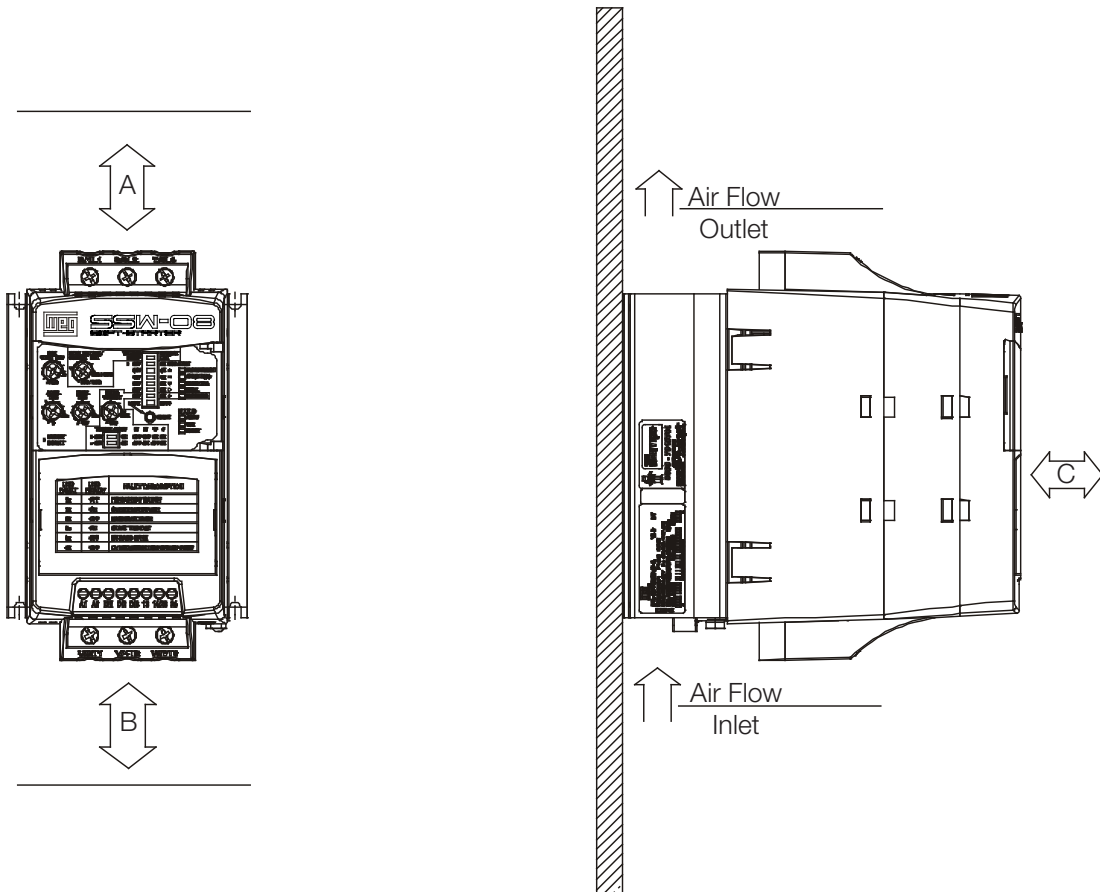

Figure 3.2: Free spaces for ventilation

3.1.3.1 Mounting Inside a Panel

For Soft-Starters SSW-08 installed in panels or closed metallic boxes exhaustion/cooling is required so the temperature does not exceed the maximum allowed. Refer to dissipated nominal power in table 3.3.

Table 3.3: Dissipated power for ventilator panel dimensioning

SSW-08 Model	Dissipated Power in the electronics (W)	Average Power dissipated 10 starts/h 3 x In @ 20 s (W)	Total Average Power dissipated 10 starts/h 3 x In @ 20 s (W)
17 A	12	6.8	18.8
24 A	12	9.6	21.6
30 A	12	12	24
45 A	12	18	30
61 A	12	24.4	36.4
85 A	12	34	46
130 A	12	52	64
171 A	12	68.4	80.4
200 A	12	80	92
255 A	36	102	138
312 A	36	125	161
365 A	36	146	182
412 A	36	165	201

3.1.3.2 Mounting on Surface

Figure 3.3 shows the installation of the Soft-Starter SSW-08 on the surface of a mounting plate.

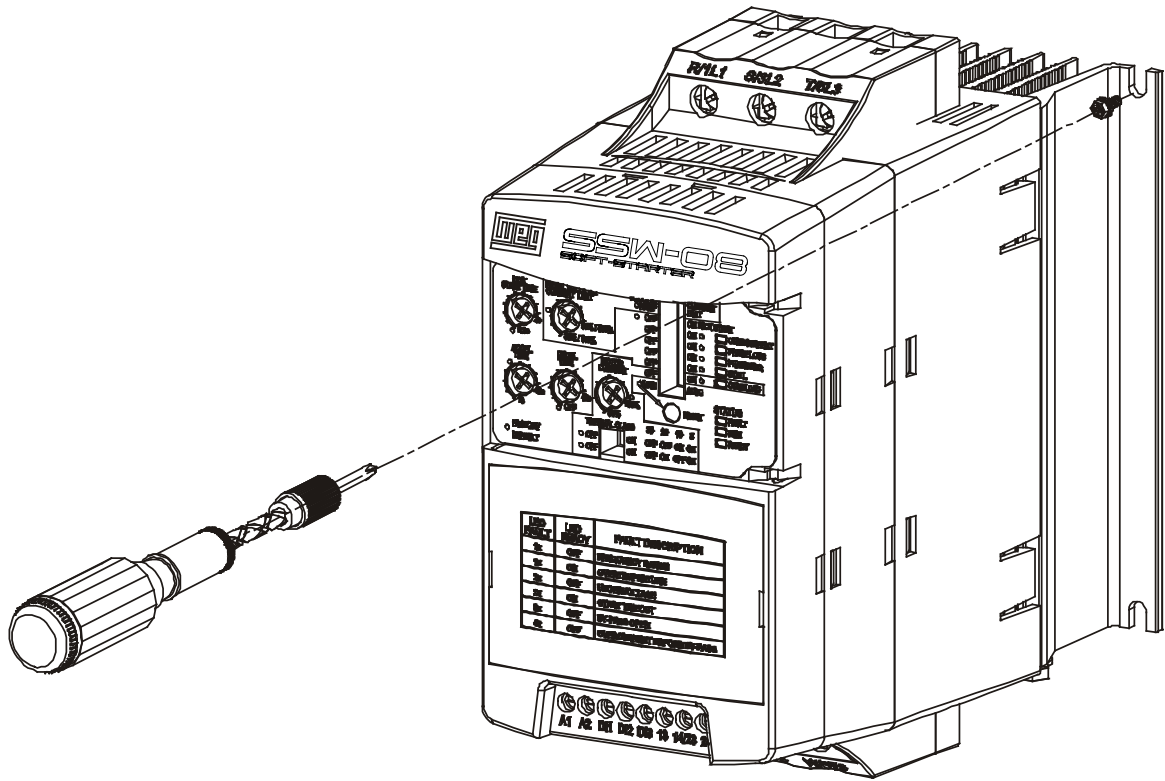

Figure 3.3: Installation procedures of the Soft-Starter SSW-08 on a surface

3.2 ELECTRICAL INSTALLATION



DANGER!

The Soft-Starter SSW-08 cannot be used as an emergency stop device. Always use an isolation contactor or a circuit breaker to disconnect the power supply of the SSW-08.



DANGER!

Be sure that the AC input power is disconnected before making any terminal connection.



ATTENTION!

The information below may be used as a guide to achieve a proper installation. Follow also the applicable local standards for electrical installations.



ATTENTION!

If a power isolating contactor or circuit breaker with minimum voltage coil is not used at the first power on, then power up the electronics first, adjust the trimpots that are necessary to put the SSW-08 into operation and only after this energize the power section.

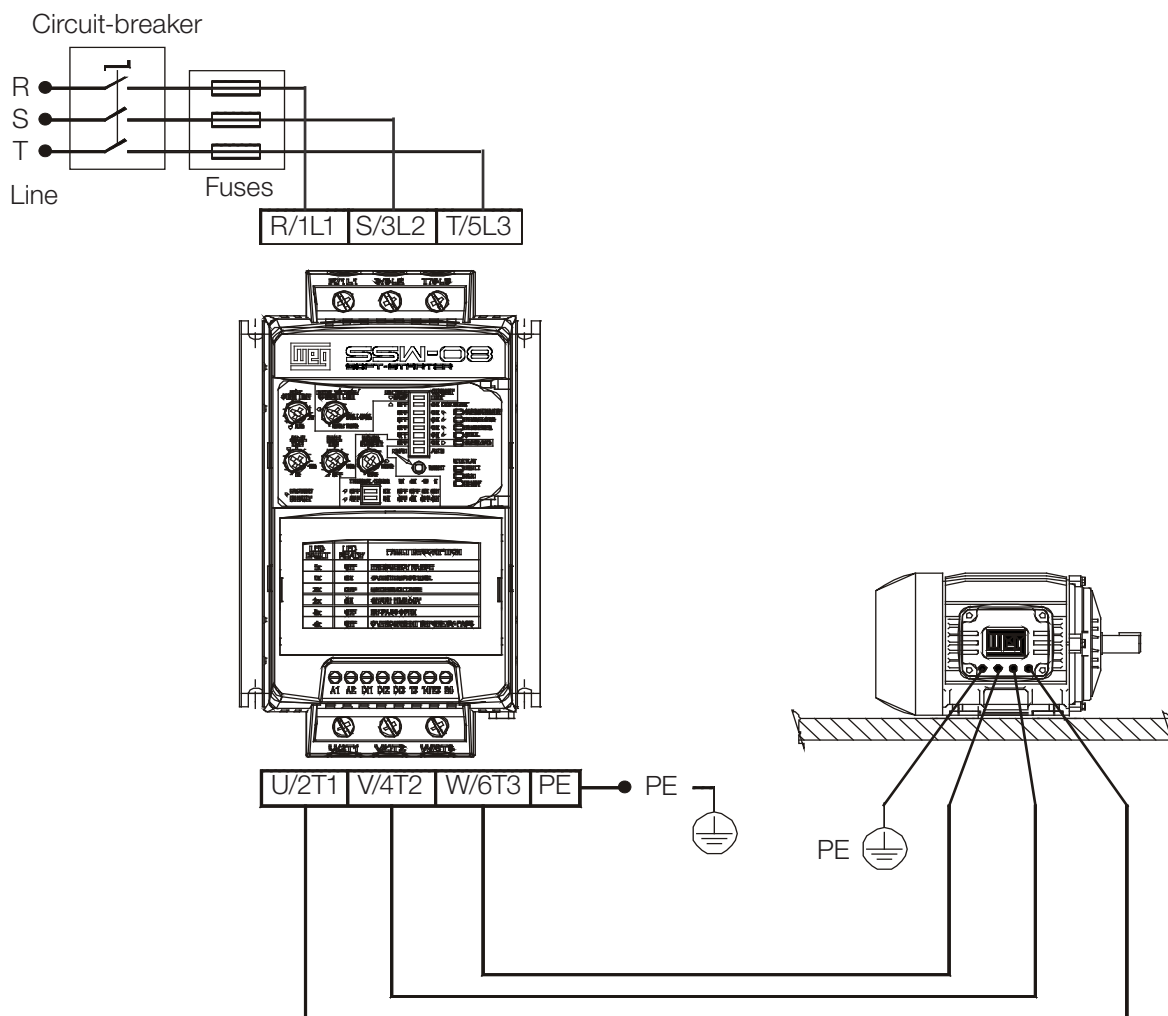

Figure 3.4: Standard power/grounding connections

3.2.1 Power Terminals

The power connection terminals can be of different sizes and configurations depending on the Soft-Starter SSW-08 model as shown in figures 3.5 and 3.6.

Terminals :

R / 1L1, S / 3L2 and T / 5L3: AC supply line.

U / 2T1, V / 4T2 and W / 6T3: Motor connection.

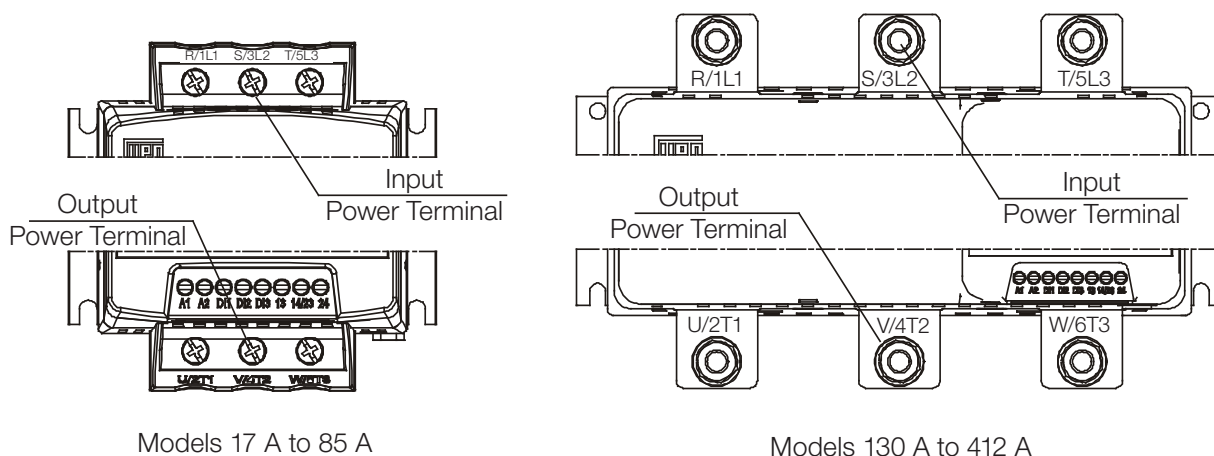

Models 17 A to 85 A

Models 130 A to 412 A

Figure 3.5: Power terminals

Table 3.4: Maximum torque for power connection

SSW-08 Model	Enclosure Size	Line / Motor		Grounding	
		Screw/ Terminal	Torque Nm (in lb)	Screw	Torque Nm (in lb)
17 A 24 A 30 A	Size 01	Terminal	3 (27)	M4 (5/32")	4.5 (40)
45 A 61 A 85 A	Size 02	Terminal	5.5 (49)	M5 (3/16")	6 (53)
130 A 171 A 200 A	Size 03	M8 (5/16")	19 (168)	M6 (1/4")	8.3 (73)
255 A 312 A 365 A 412 A	Size 04	M10 (3/8")	37 (328)	Terminal	0.5 (4.5)

3.2.2 Location of the Grounding, Control and Power Connections

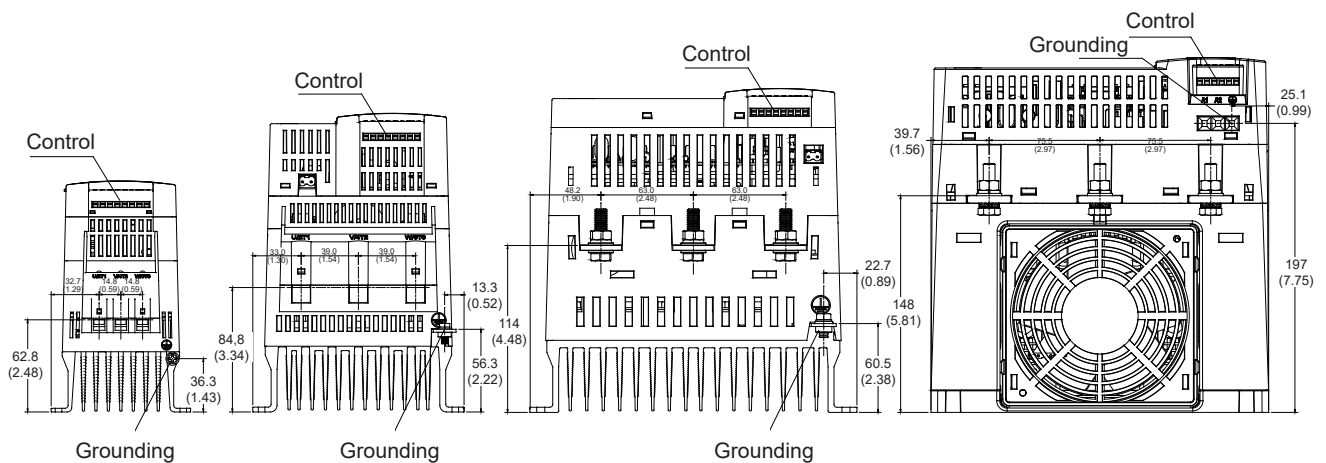

Dimensions in mm (in).

Figure 3.6: Location of the grounding, control and power connections

3.2.3 Recommended Power and Grounding Cables

The described specifications in table 3.5 are valid only for the following conditions:

- Copper wires for 70 °C (158 °F) with PVC insulation for ambient temperature of 40 °C (104 °F), installed in perforated and not agglomerated conduits.
- Naked or silver coated copper busbars with round edges with 1 mm radius with ambient temperature of 40 °C (104 °F) and bus temperature of 80 °C (176 °F).



NOTE!

For correct cable dimensioning, consider the installation condition and the maximum permitted line voltage drop.

Table 3.5: Minimum cable gauge specification

SSW-08 Model	Power Cable		Grounding Cable	
	(mm ²)	AWG	(mm ²)	AWG
17 A	4	12	4	12
24 A	6	10	6	10
30 A	6	10	6	10
45 A	10	8	6	10
61 A	16	6	10	8
85 A	25	4	10	8
130 A	50	1	25	4
171 A	70	2/0	35	2
200 A	95	3/0	50	1
255 A	120	250 kcmil	2.5	14
312 A	185	350 kcmil	2.5	14
365 A	240	500 kcmil	2.5	14
412 A	300	600 kcmil	2.5	14

3

3.2.4 Power Supply Connection to the Soft-Starter SSW-08



DANGER!

The AC input must be compatible with the voltage range of the Soft-Starter SSW-08.



DANGER!

Provide a power supply disconnecting switch for the Soft-Starter SSW-08. This disconnecting switch must disconnect the AC input voltage to the Soft-Starter SSW-08 whenever necessary (for example: during maintenance services).

If a disconnected switch or a contactor is inserted in the motor supply line never operate these devices with the motor running or when the Soft-Starter SSW-08 is enabled.



ATTENTION!

Over-voltage control in the line that supplies the Soft-Starter must be made using over-voltage protections of 680 Vac (phase to phase connection) and energy absorption capacity of 40 joules (17 A to 200 A models) and 80 joules (255 A to 412 A models).



NOTE!

Use the wire sizes and fuses recommended in tables 3.5, 3.6 and 3.7. The connector tightening torque is indicated in table 3.4. Use only copper wires 70 °C (158 °F).

3.2.4.1 Short Circuit Capacity, Fuses, Circuit Breaker – UL

Table 3.6 presents the short circuit capacity, Standard Fault, of the power supply (symmetric Arms) at which the SSW-08 can be installed, provided that protected by means of regular fuses or circuit breakers, used in the UL tests.

Table 3.6: Short circuit capacity – UL Standard Fault

SSW-08 Model	Nominal Rating	Short Circuit Rating $\leq 600V$	Circuit Breaker (CB) - UL489 Any MCCB	Ultra-fast Fuses Ferraz Shawmut/ Mersen Flush End Contacts	Ultra-fast Fuses Cooper Bussmann Bolted Contacts
17 A	17 A	5 kA	< 30 A	6.6URD30TTF0050	170M2611
24 A	24 A	5 kA	< 40 A	6.6URD30TTF0080	170M1366
30 A	30 A	5 kA	< 40 A	6.6URD30TTF0080	170M1366
45 A	45 A	5 kA	< 150 A	6.6URD30TTF0100	170M1367
61 A	61 A	5 kA	< 150 A	6.6URD30TTF0125	170M1368
85 A	85 A	10 kA	< 150 A	6.6URD30TTF0200	170M1370
130 A	130 A	10 kA	< 225 A	6.6URD31TTF0325	170M1372
171 A	171 A	10 kA	< 250 A	6.6URD32TTF0450	170M3170
200 A	200 A	10 kA	< 250 A	6.6URD32TTF0500	170M3171
255 A	255 A	18 kA	< 400 A	6.6URD32TTF0400	170M5158
312 A	312 A	18 kA	< 400 A	6.6URD33TTF0500	170M3171
365 A	365 A	18 kA	< 600 A	6.6URD33TTF0550	170M5161
412 A	412 A	18 kA	< 600 A	6.6URD33TTF0700	170M6161

The fuses in table 3.6 used in the SSW-08 UL tests are of the ultra-fast (aR) type, which also reduce the risk of SCRs being burned by over current transients.

Table 3.7, presents the short circuit capacity, High Fault, of the power supply (symmetric Arms) at which the SSW-08 can be installed within a closed panel, provided that protected by means of circuit breakers, used in the UL tests.

3.2.4.2 Input Circuit Breakers and Fuses – IEC

Ultra-fast fuses (aR), regular fuses or circuit breakers:

For Coordination Type 1, regular fuses or circuit breakers can be used, according to IEC 60947-4-2, which will protect the installation against short circuits, however, the SCRs will not be protected. Circuit breakers of the table 3.6.

For Coordination Type 2, the fuses to be used in the input must be for protection of semiconductors, ultra-fast type (aR), according to IEC 60947-4-2. They reduce the risk of the SCRs to burn out because of overcurrent transients.

Table 3.7: I²t of the SCR and aR Weg fuses

SSW-08 Model	I ² t SCR (A ² s)	FNH aR Blade Contacts
17 A	720	FNH1-63-K-A
24 A	4000	FNH00-80-K-A
30 A	4000	FNH00-100-K-A
45 A	8000	FNH00-160-K-A
61 A	10500	FNH00-200-K-A
85 A	51200	FNH00-250-K-A
130 A	97000	FNH1-400-K-A
171 A	168000	FNH2-500-K-A
200 A	245000	FNH2-630-K-A
255 A	90000	FNH3-500-K-A
312 A	238000	FNH3-710-K-A
365 A	238000	FNH3-710-K-A
412 A	320000	2 x FNH3-500-K-A

Ultra-fast fuses (aR), with I²t smaller than or equal to 75 % of the value of the SCR indicated (A²s) in table 3.7.



NOTE!

The maximum I²t of the fuse of the SSWs varies according to the design of the SCR used; therefore, higher rated currents may present lower I²t.

The fuse rated current should preferably be equal to or higher than the motor starting current in order to prevent cyclic overloads and the tripping of the fuse in the prohibited area of the Time x Current curve.

The proper sizing of the fuse should take into account: the local standards for electrical installations, the starting cycle, number of starts per hour, starting current and starting time, ambient temperature and altitude.

For the correct sizing of the fuses, see WEG Fuse Catalog:

www.weg.net

Automation - Fuses aR and gL/gG - Type NH Blade Contact, NH Flush End and Diametral.

Annex 1: Sizing Criteria for Ultra-Fast Fuses aR Blade Contact and Flush End.

Annex 2: Table for aR Fuse Sizing to Protect SSW Soft-Starters and CFW Inverters.

3.2.4.3 Control Fuse

For the electronic supply protection of the SSW-08 must be used fuse type D, or circuit breaker type C: Fuse 2 A Type D or Circuit breakers 2 A Type C.

3.2.5 Soft-Starter SSW-08 Connection to the Motor

**DANGER!**

Power factor correction capacitors must never be installed at the output of the Soft-Starter SSW-08. (U / 2T1, V / 4T2 and W / 6T3).

**ATTENTION!**

To ensure that the protections based on the current reading and display operate correctly, for example the overload, the motor nominal current must not be lower than 50 % of the nominal Soft-Starter SSW-08 current.

**NOTE!**

Use the wire sizes and fuses recommended in tables 3.5, 3.6 and 3.7. The connector tightening torque is indicated in table 3.4. Use only copper wires.

**NOTE!**

The Soft-Starter SSW-08 is provided with electronic protection against motor overload. This protection must be set according to the specific motor. When several motors are connected to the same Soft-Starter SSW-08 use individual overload relays for each motor.

3.2.5.1 Standard Three-Wire Connection

Line current of the Soft-Starter SSW-08 is equal to the motor current.

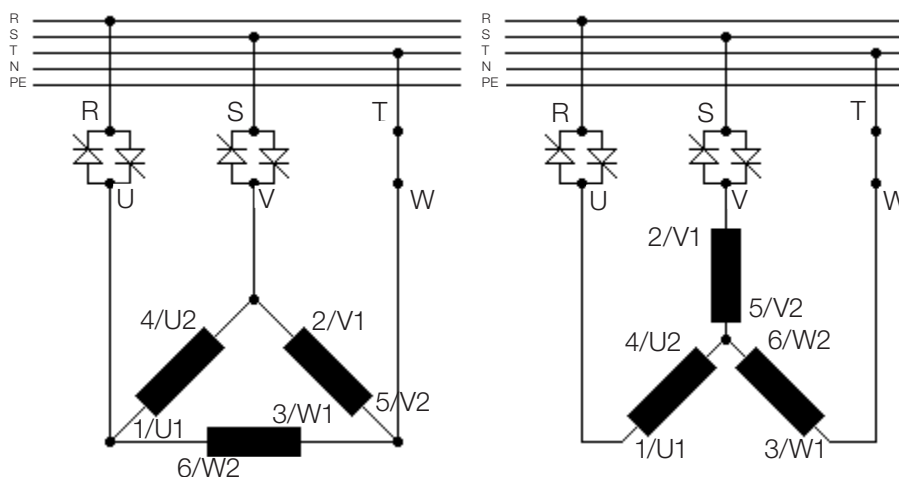

Figure 3.7: Soft-Starter SSW-08 with standard connection

3.2.6 Grounding Connections



DANGER!

The Soft-Starter must be grounded for safety purposes (PE). The ground connection must comply with the local regulations. For grounding use cables with cross sections as indicated in table 3.5. Make the ground connection to a grounding bar or to the general grounding point (resistance ≤ 10 ohms).



DANGER!

The AC input for the Soft-Starter SSW-08 must have a ground connection.



DANGER!

Do not use the neutral conductor for grounding purpose. Use dedicated ground conductor.



ATTENTION!

Do not share the ground wiring with other equipment that operate with high current (for examples: high voltage motors, welding machines, etc.). When several Soft-Starters SSW-08 are used, observe the connections in the figure 3.8.

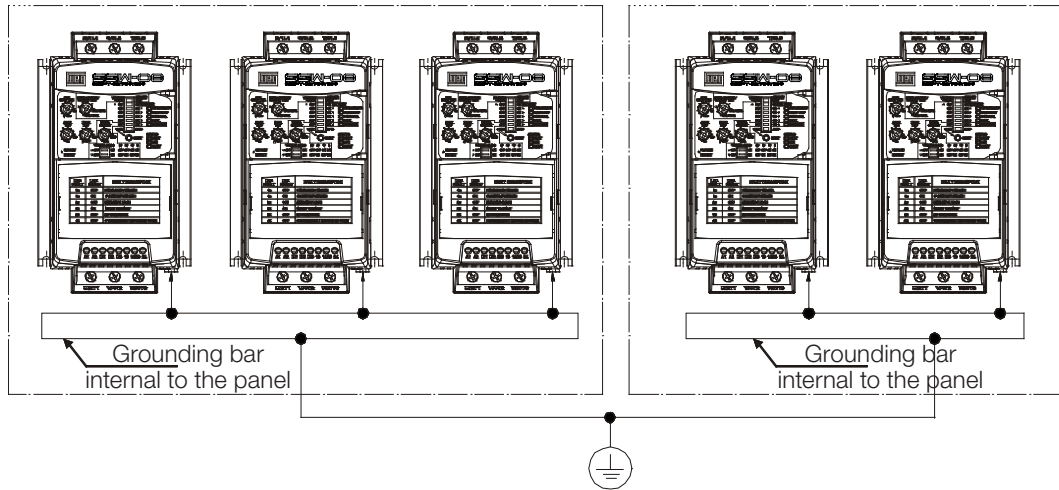

Figure 3.8: Grounding connections for more than one Soft-Starter SSW-08

EMI - Electronic Interference

The Soft-Starter SSW-08 is developed to be used in industrial systems (Class A) according to Standard EN60947-4-2.

It's necessary to have a distance of 0.25 m (10 in) between the Soft-Starter SSW-08 and the cables between the Soft-Starter SSW-08 and the motor.

Example: CLP wiring, temperature controllers, thermocouple cables, etc.

Grounding of the Motor frame

Always ground the motor frame. Ground the motor in a panel where the Soft-Starter SSW-08 is installed. The Soft-Starter SSW-08 output wiring to the motor must be installed separately from the input wiring as well as from the control and signal wiring.

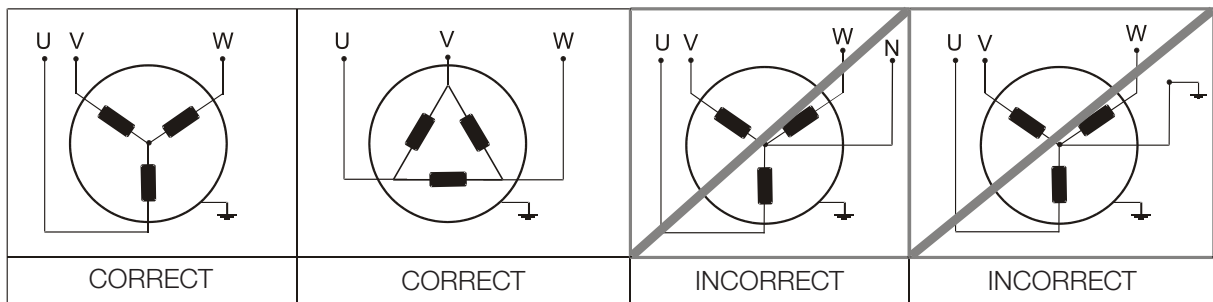

ATTENTION!

Only the motor frame shall be grounded.

3.2.7 Control and Signal Connections

The control connections (digital inputs and relay outputs) are made through the terminals (refer to figure 3.9).

Gauge of the cables: 0.5 mm² (20 AWG) to 1.5 mm² (14 AWG).

Table 3.8: Description of the control connector pins

Terminal	Description	Specifications	Torque Nm (in lb)
A1	Electronics Supply	Voltage: 110 to 240 Vac (-15 % to +10 %) (models from 17 A to 200 A)	0.5 (4.5)
A2		110 to 130 Vac or 208 to 240 Vac (-15 % to 10 %) (models from 255 A to 412 A).	
	Grounding	Only for the 255 to 412 A models	
Terminal	Factory Default	Specifications	
DI1	Starts/Stops Motor	3 isolated digital inputs Voltage: 110 to 240 Vac (-15 % to +10 %) Current: 2 mA Max.	
DI2	Fault reset		
DI3	Fault reset		
13	Relay 1 output - Operation	Contact capacity:	
14/23	Relay common point	Voltage: 250 Vac	
24	Relay 2 output - Full voltage	Current: 1 A	

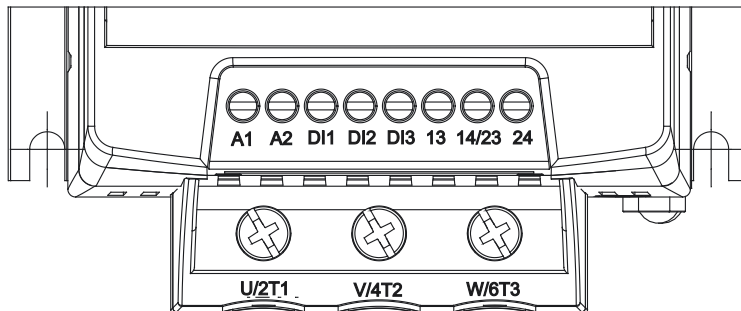

Figure 3.9: Control terminals of the Soft-Starter SSW-08



NOTE!

It is recommended to use shielded cables for the Dix inputs when using long cables (above 30m) in noisy environments. The metallic shield and A2 must be grounded.

3.3 RECOMMENDED SET-UPS

Some recommended set-ups are shown here and they can be completely or partly used. The main warning notes for all the recommended set-ups are shown below and are described in the schemes by their respective numbers.

NOTE!

- ① For the protection of the whole electrical installation it is necessary to use fuses or circuit breakers. The use of ultra-rapid fuses is not required for the operation of the Soft-Starter SSW-08 but they are recommended for the complete SCR protection.
- ② The transformer “T1” is optional and must be used when there is a difference between the line voltage and the electronic power voltage.
- ③ To protect the motor from damage by possible short-circuits in the power circuit of the Soft-Starter SSW-08 use an isolating contactor (K1) or circuit-breaker (Q1).
- ④ Start push-button.
- ⑤ Stop push-button.
- ⑥ Start/Stop switch, remember that when the command via two-wire digital input is used (the switch is normally open with retention) every time the power supply is restored after any fault the motor will start immediately if the switch remains closed.
- ⑦ In case of maintenance of the Soft-Starter SSW-08 or the motor it is necessary to remove the input fuses or disconnect the power supply to ensure the complete equipment disconnection from the power supply.
- ⑧ The emergency stop can be used by disconnecting the electronics power supply.
- ⑨ Undervoltage release for the Q1 power isolation circuit breaker.

3.3.1 Recommended Set-up with Command via Two-wire Digital Inputs and Isolation Contactor

Figure 3.10: Recommended set-up with commands via two-wire digital inputs and isolation contactor

3.3.2 Recommended Set-up with Command via Three-wire Digital Inputs and Circuit-Breaker

3

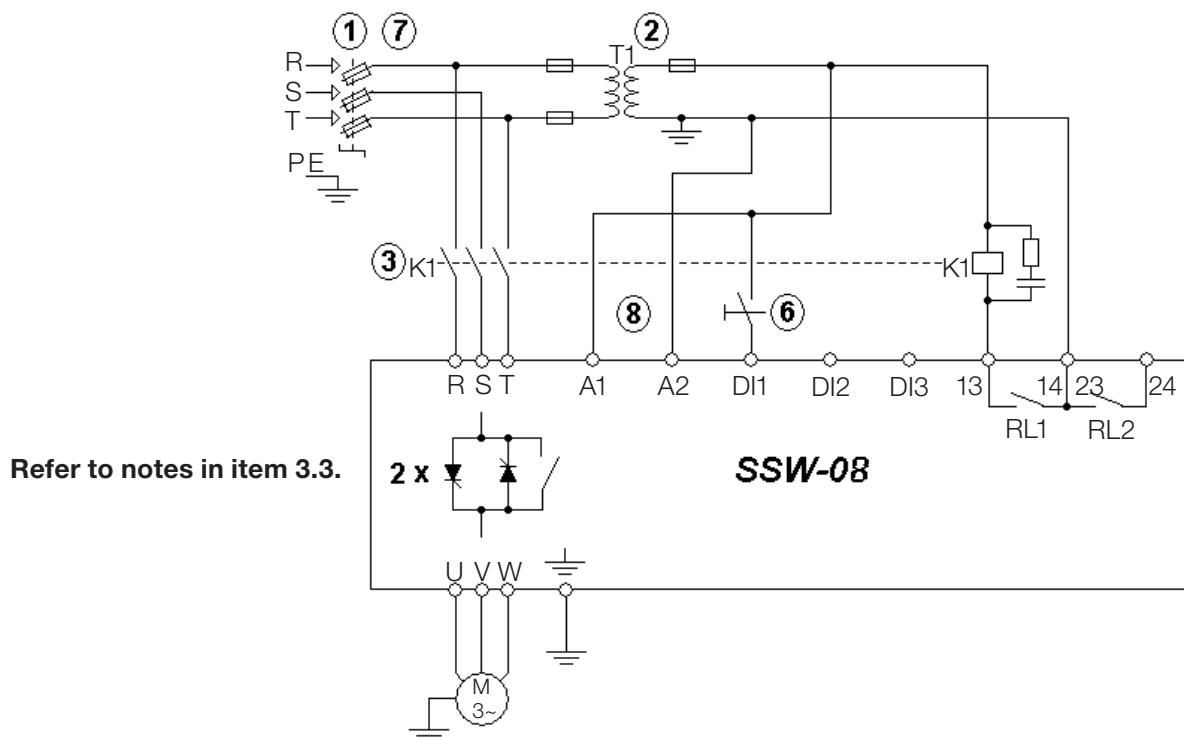
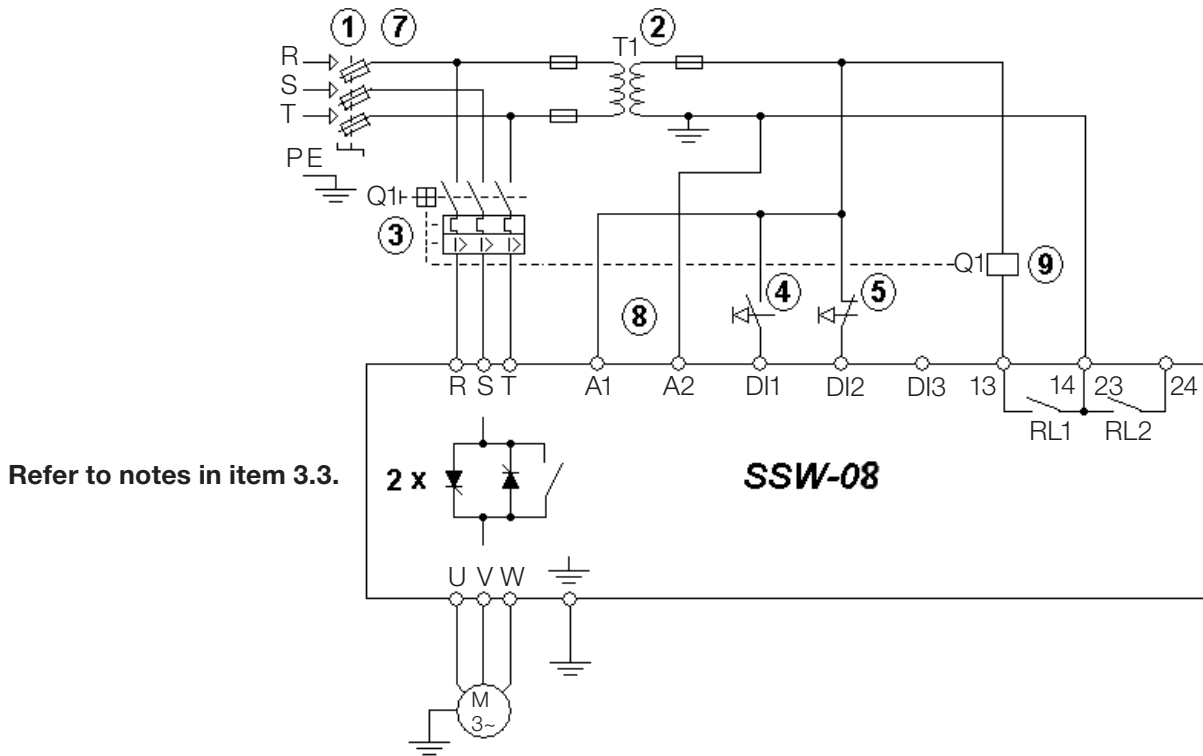

Figure 3.11: Recommended set-up with commands via three-wire digital inputs and a circuit-breaker

✔ **NOTE!**
It's necessary to program the digital input DI2 for the three-wire command. Refer to item 4.10.

✔ **NOTE!**
The RL1 shall be set to the "No fault" function. Refer to item 4.12.

3.3.3 Recommended Set-up with Command via Two-wire Digital Inputs and Direction of Rotation

- P220 = 1
- P230 = 1
- P263 = 1 (DI1 = Start/Stop two wires)
- P265 = 4 (DI3 = Rotation Direction)
- P277 = 4 (RL1 = FWD/REV - K1)
- P278 = 4 (RL2 = FWD/REV - K2)
- P620 = 0 (RST phase sequence = Inactive)

Refer to notes in item 3.3

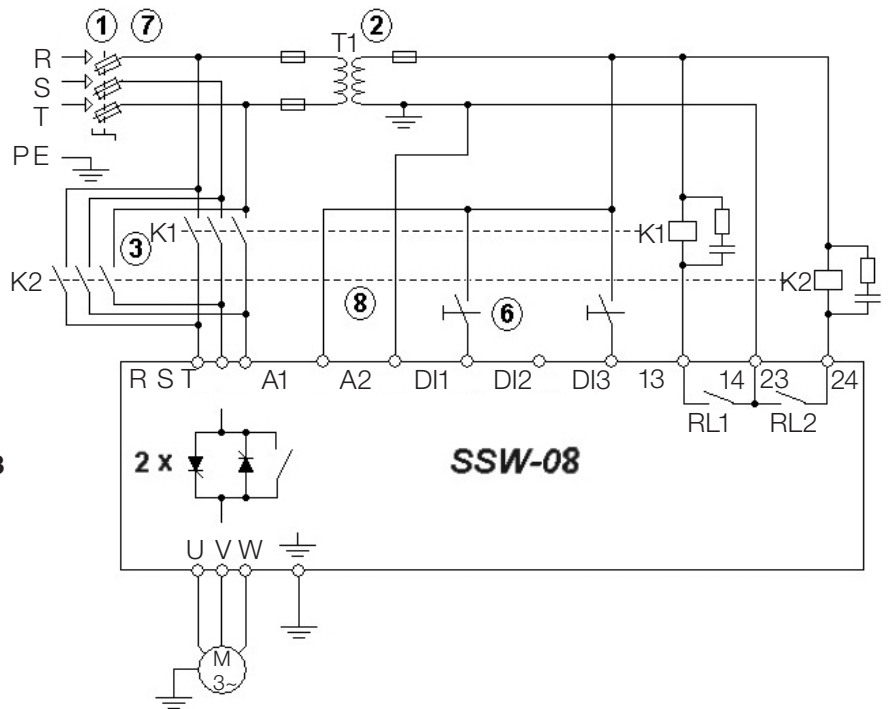

Figure 3.12: Recommended Set-up with Command via Two-wire Digital Inputs and Direction of Rotation



NOTE!

To program the parameters shown above, is necessary the use of keypad or serial communication. See the Programming Manual for more information.

3.3.4 Recommended Set-up with Command via Two-wires Digital Inputs and DC-Braking

- P220 = 1
- P230 = 1
- P263 = 1 (DI1 = Start/Stop two wires)
- P265 = 5 (DI3 = Brake Off)
- P277 = 1 (RL1 = Running)
- P278 = 5 (RL2 = DC-Braking)
- P501 ≥ 1 (DC Braking Time ≥ 1s)

Refer to notes in item 3.3

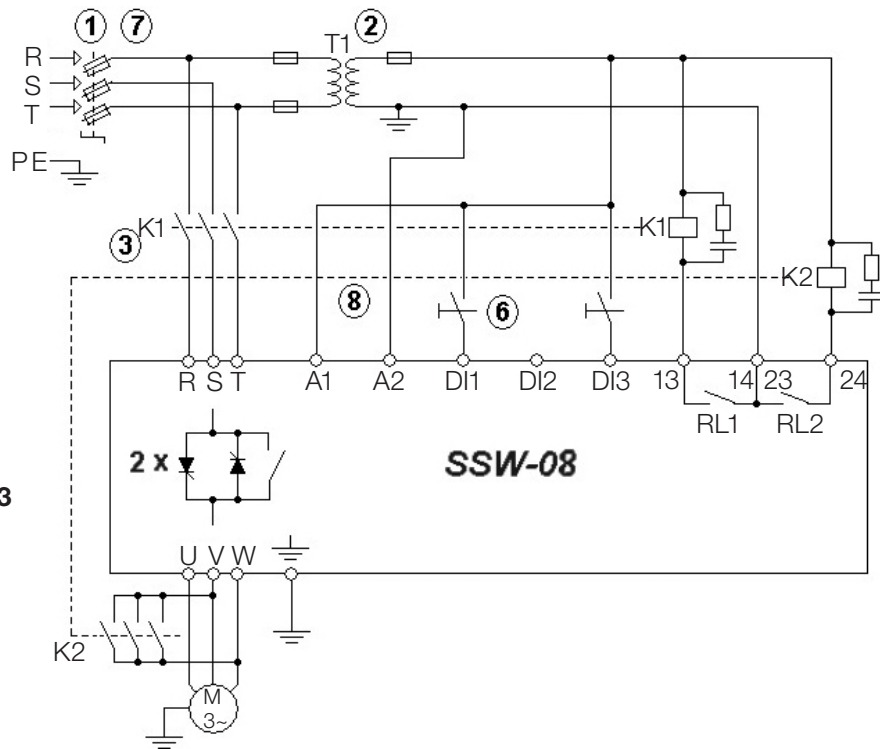

Figure 3.13: Recommended Set-up with Command via Two-wires Digital Inputs and DC-Braking



NOTE!

To program the parameters shown above, is necessary the use of keypad or serial communication. See the Programming Manual for more information.

3.3.5 Symbols

	Electrical connection between two signals
	Connection terminals
	Relay or contactor coil
	Normally open contact (NO)
	Indicator light
	Circuit-breaker (opens under load)
	Resistor
	Capacitor

	Fuse
	Thyristor/SCR
	Three-phase motor
	Emergency button
	Transformer
	N.O Contact (with retention)
	Normally closed (NC) push-button
	Normally open (NO) push-button
	Circuit-breaker with undervoltage release

4. SETTING THE SSW-08

This chapter describes how to make the necessary settings for the correct functioning of the SSW-08.

4.1 CONTROL TYPE SETTING

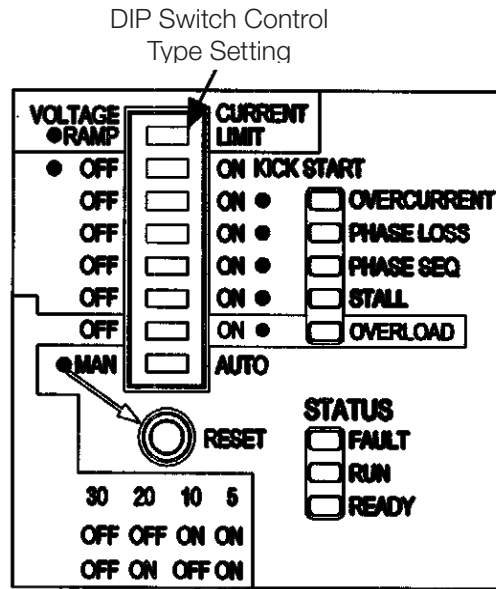

Figure 4.1: Control type setting

Select the type of starting control that best adapts to the application.

Voltage Ramp Starting:

This is the most commonly used method. Very easy to program and set. The Soft-Starter SSW-08 imposes the voltage applied to the motor. Generally applied to loads with a lower initial torque or a square torque. This kind of control can be used as an initial working test.

Current Limit Starting:

The maximum current level is maintained during the start, being set according to the application necessities. Generally applied to loads with a higher initial torque or a constant torque. This kind of control is used to adapt the start to the capacity limits of the supply network.



NOTES!

1. The Current Ramp control type, is only programmed using keypad or serial communication. See the Programming Manual for more details.
2. To program the control type in Pump control, see the Programming Manual or item 5.1.4.

4.2 KICK START

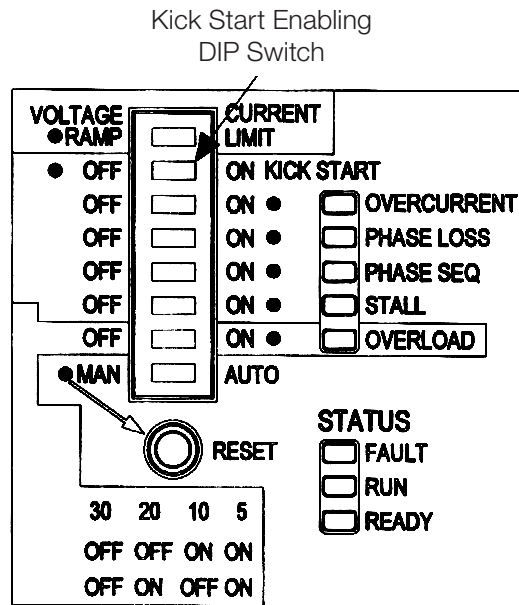

Figure 4.2: Kick Start enabling

Soft-Starter SSW-08 offers a Kick Start function for loads that present a large initial resistance to movement.

This function is enabled through the Kick Start DIP Switch. The duration of the voltage pulse is set through the trimpot Kick Start Time.

The voltage pulse applied is of 80 % U_n during the programmed trimpot Kick Start Time.

NOTE! Use this function only for specific applications and where necessary.

4.3 INITIAL VOLTAGE SETTING

Set the initial voltage to a value that the motor starts to run as soon as the start command is given to the SSW-08.

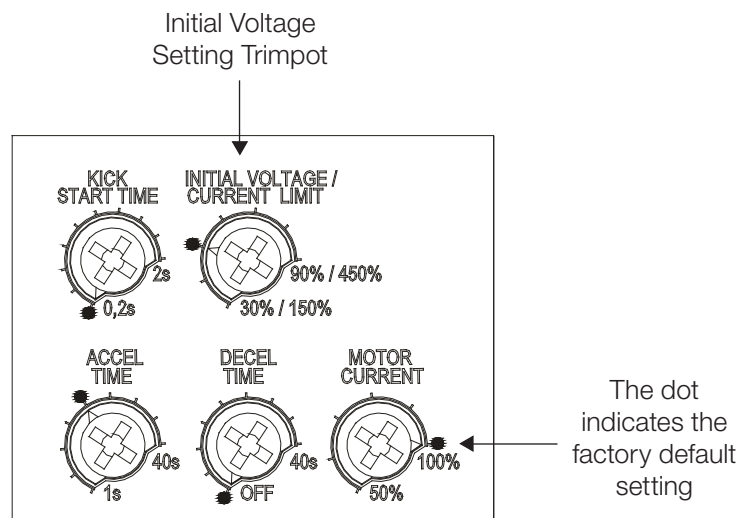

Figure 4.3: Initial voltage setting



NOTE!

The Initial Voltage trimpot has an initial voltage setting function only when the kind of control is programmed to start with a voltage ramp.

4.4 CURRENT LIMIT SETTING

This setting defines the maximum limit of the current from phases R and S during motor starting in percentage of the nominal current of the Soft-Starter.

If the current limit is reached during the start of the motor, Soft-Starter SSW-08 will maintain the current at this limit until the motor reaches nominal speed.

If the current limit is not reached, the motor will start immediately.

The current limitation should be set to a level that the motor acceleration can be observed, otherwise the motor will not start.

4

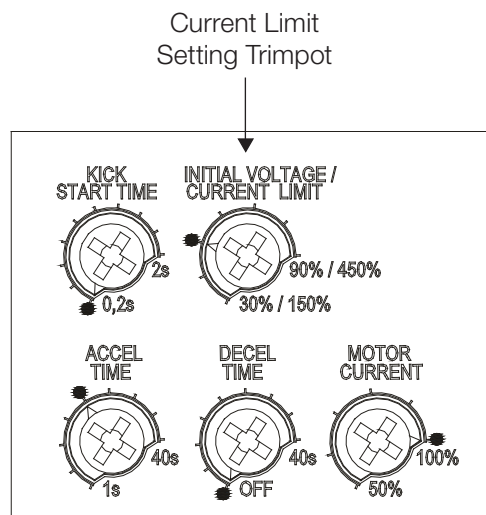

Figure 4.4: Current limit setting



NOTE!

If at the end of the acceleration ramp (set at the Trimpot Acceleration Time), full voltage is not reached, a start timeout Fault will be shown. This fault is indicated through the Fault LED flashing twice with the Ready LED on.

The trimpot Current Limit has a Current Limit setting function only when the kind of control is programmed to start with a Current Limit.

4.5 ACCELERATION RAMP TIME SETTING

When Soft-Starter SSW-08 is programmed to Voltage Ramp control, this is the voltage increment ramp time.

When Soft-Starter SSW-08 is programmed to Current Limit control, this time is used as the maximum starting time, working as a protection against blocked rotors.

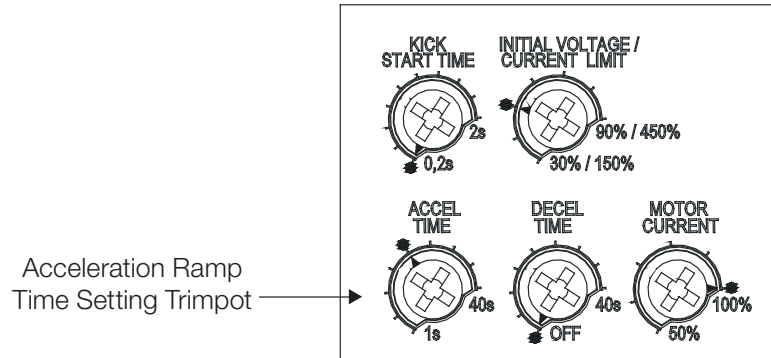

Figure 4.5: Acceleration ramp time setting



NOTE!

The programmed acceleration time is not the exact motor acceleration time, but the time of the voltage ramp or the maximum starting time. The motor acceleration time depends on the motor characteristics and the load.

Please consider that in cases where the relation of the SSW-08 current and the motor nominal current is 1.00, the maximum time that the SSW-08 can work with $3 \times I_n$ is 20 seconds.

4.6 DECELERATION RAMP TIME SETTING

Enables and sets the time of voltage decrease.

This setting should be used only for the deceleration of pumps to reduce the water hammer. This setting must be made to achieve the best pump performance.



NOTE!

This function is used to lengthen the normal deceleration time of a load and not to force a lower time than that imposed by the load itself.

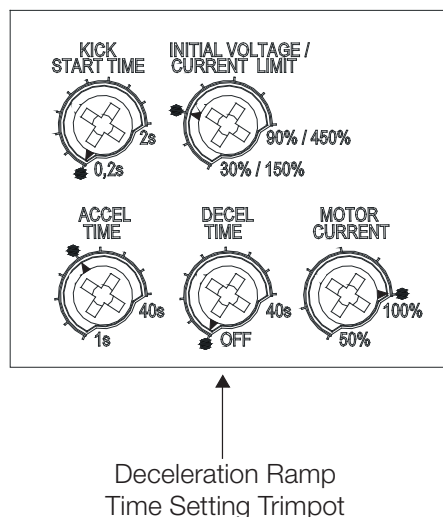

Figure 4.6: Deceleration ramp time setting

4.7 MOTOR CURRENT SETTING

This setting defines the ratio of the SSW-08 current and the motor current. The value of the setting is very important since it defines the protection of the motor driven by the SSW-08. The setting of this function interferes directly in the following motor protections:

- Overload;
- Overcurrent;
- Stall;
- Phase loss.

Calculation Example:

SSW-08 Used: 30 A

Motor Used: 25 A

4 Trimpot for the Motor Current Setting

$$\text{Motor Current Setting} = \frac{I_{\text{motor}}}{I_{\text{SSW-08}}}$$

$$\text{Motor Current Setting} = \frac{25 \text{ A}}{30 \text{ A}}$$

$$\text{Motor Current Setting} = 0.833$$

Therefore it must be set at 83 %

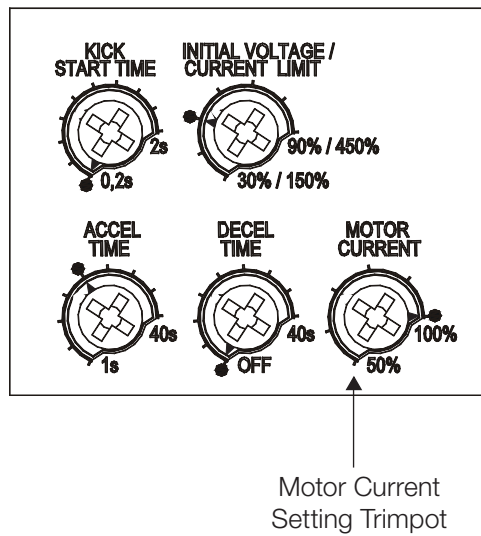

Figure 4.7: Motor current setting

4.8 MOTOR ELECTRONIC OVERLOAD PROTECTION

The motor electronic overload protection simulates the heating and cooling of the motor, also known as thermal image. This simulation uses as input data the True rms current. When the thermal image passes the limit, the overload protection trips and turns the motor off. The adjustment of the thermal class is based on the motor locked rotor current and locked rotor time. With this data it is possible to find a point in the figure to determine, which thermal class protects the motor. Please refer to figure 4.8 for cold stall time or to figure 4.9 for hot stall time. The thermal classes below the point protect the motor.

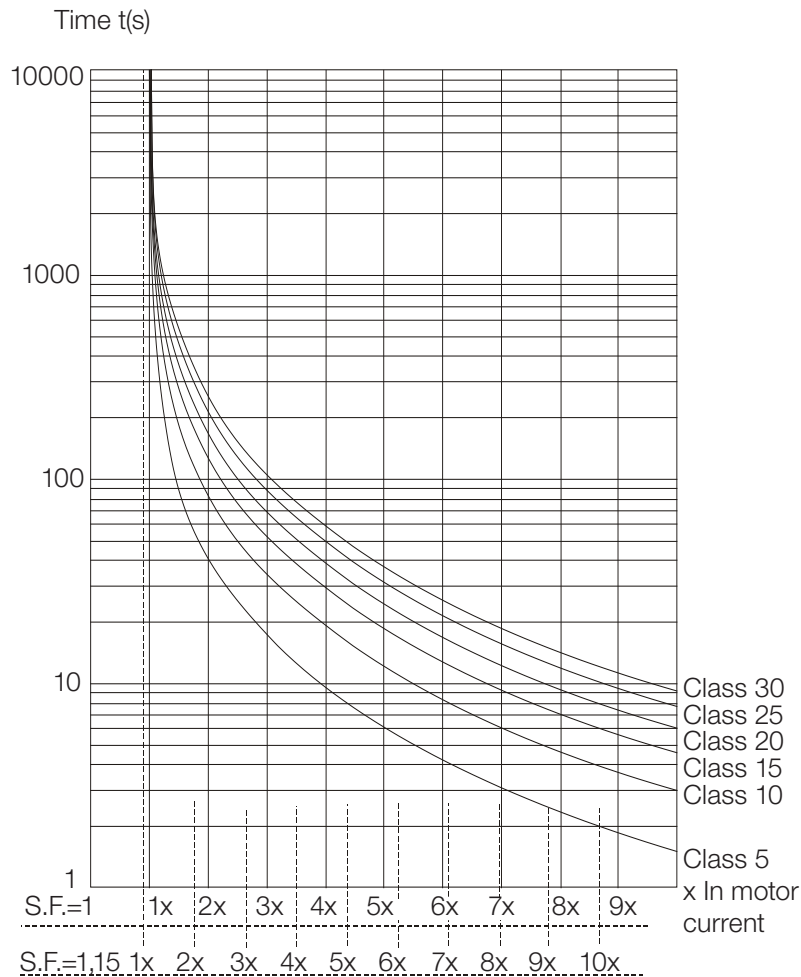

Figure 4.8: Thermal classes of motor protection in cold condition

4

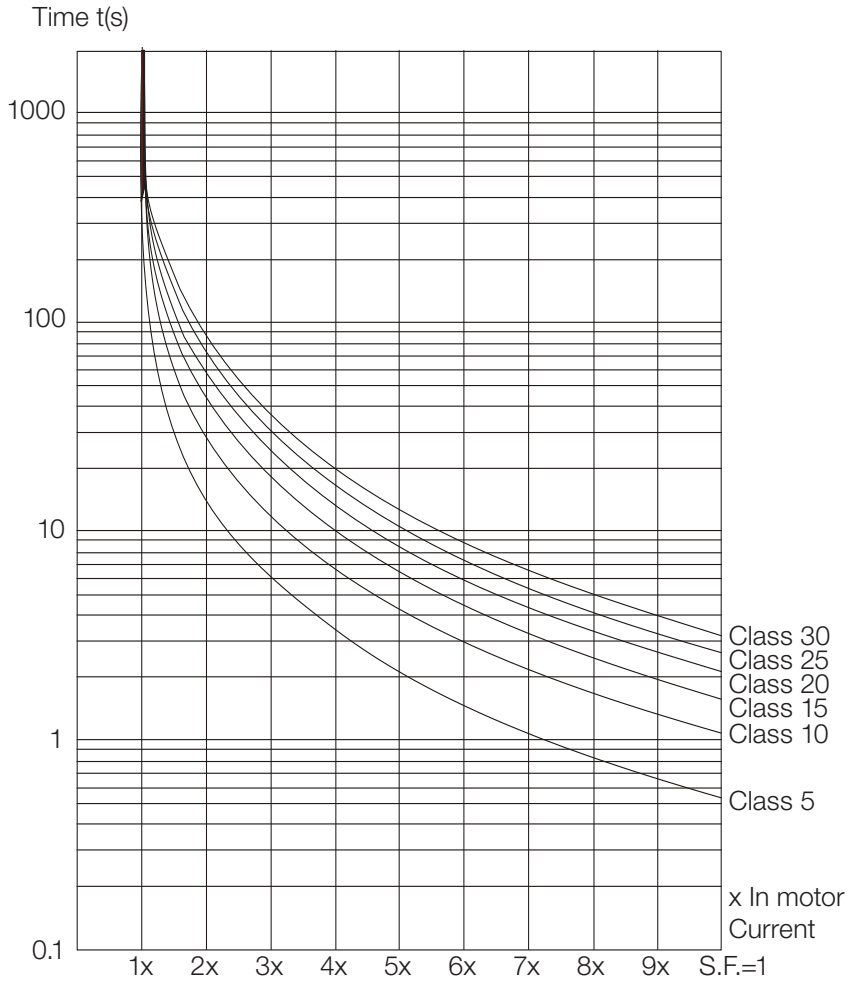

Figure 4.9: Motor protection thermal classes in hot condition at 100 % In

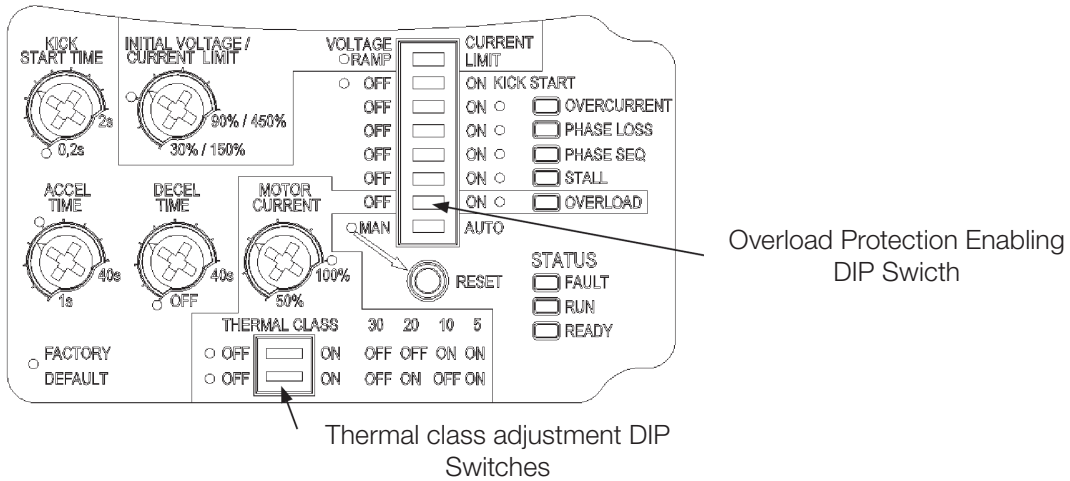

Figure 4.10: Overload protection Enabling and Adjustment

**NOTES!**

- Adjust the motor current according to chapter 4.7 for the correct function of the overload protection;
- This protection is based on Three Phase IP55 Standard WEG motors. If your motor is different, we recommend to adjusting a lower thermal class. For more details refer to chapter 5.2;
- When SSW-08 is without the electronic supply voltage (A1 and A2), the thermal image is saved internally. When the supply (A1 and A2) is reestablished, the thermal image returns to the value prior to the electronic supply loss;
- The RESET of the electronic overload protection can be set to manual function (man). In this case the RESET must be made via digital input 2 (DI2) or through the RESET key. If the RESET setting is automatic (auto), the fault condition will automatically be reset after the cooling time;
- The thermal image is set to zero, when the overload protection is disabled.

4.9 RESET

A fault condition can be reset using the RESET key at the front of the SSW-08 or through a push-button (0.5 seconds) at DI3 (digital input for RESET). Another way to reset the SSW-08 is by switching Off/On the electronic power supply (A1 and A2).

**NOTE!**

The SSW-08 also allows for the possibility of automatic RESET by enabling this function through the DIP Switch (auto):

- Automatic RESET occurs after 15 minutes in the following conditions:
 - Overcurrent;
 - Phase loss;
 - Stall;
 - Overcurrent before By-pass;
 - Frequency out of range;
 - Contact of the internal By-pass relay is open;
 - Power control supply undervoltage;
 - External fault.
- For incorrect phase sequence there is no automatic RESET.
- For electronic overload of the motor there is a specific algorithm for the automatic RESET time.

4.10 DI2 DIGITAL INPUT SETTING

In the factory default, the DI2 digital input has its function programmed for the reset of faults. DI2 can also be programmed to work as a three wire control.

The three wire control allows the Soft-Starter to be commanded through two digital inputs, DI1 as an ON input and DI2 as an OFF input. This allows for the direct placement of two push buttons. Refer to item 3.3.2.

To change the DI2 digital input, follow the instructions below:

1. To enter in programming mode, maintain the reset key at the front of the SSW-08 pressed for 5 seconds. Maintain the reset key pressed during programming;
2. When in programming mode, two LEDs will turn on (overcurrent and phase loss), indicating that DI2 is programmed for fault Reset. When three LEDs turn on (overcurrent, phase loss and phase sequence), it indicates that the DI2 is programmed for three wire commands;

3. To change the programming to three wire commands, move the overcurrent DIP Switch and return to the previous position. The three LEDs will turn on, indicating that DI2 is programmed for three wire commands;
4. To change the DI2 programming to fault Reset, move the Kick Start DIP Switch and return to the previous position. Two LEDs will turn on, indicating that the DI2 is programmed for fault Reset;
5. Programming is concluded when the reset key is released.

4.11 OUTPUT RELAY OPERATION

- The relay of the Operation Function closes its N.O. contact (13-14/23) every time the SSW-08 receives the enable command. This contact is only opened at the end of the deceleration ramp (when it is set via trimpot) or when the SSW-08 receives the disable command.
- The relay of the Full Voltage Function closes the N.O. contacts (14/23-24) every time the SSW-08 applies 100 % of the voltage to the driven motor. This contact opens when the SSW-08 receives the disable command.

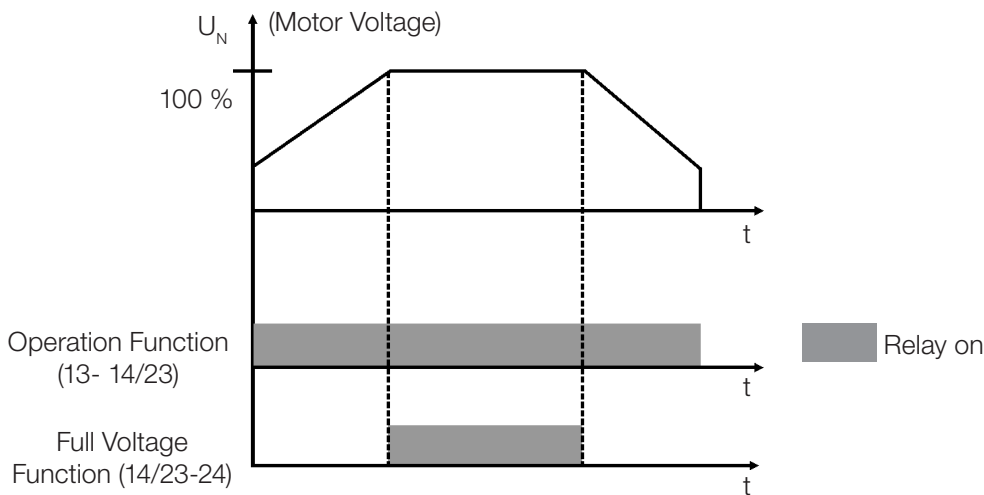

Figure 4.10: Output relay operation

4.12 RELAY OUTPUT RL1 PROGRAMMING

In the factory default programming, the relay output RL1 has its function programmed for “Operation”. RL1 (13/14) can be also be programmed for the “No Fault” function. This function allows the installation of a circuit breaker with an undervoltage release at the SSW-08 input. Refer to figure 3.3.2. In order to change the relay output RL1 programming follow these instructions:

1. To enter in programming mode keep the reset key, at the SSW-08 front cover, pressed during 5 seconds, keeping it also pressed throughout the programming;
2. When in the programming mode two LEDs turn on (Overcurrent and Phase Loss), indicating that DI2 is programmed for Error Reset. If three LEDs turn on (Overcurrent, Phase Loss and Phase Sequence), it indicates that DI2 is programmed for three-wire command. If the Overload LED turns on, then the RL1 function is “No Fault”, otherwise the function is “Operation”;
3. To modify the RL1 function change the Overload DIP Switch and put it back in the previous position. The Overload LED will indicate the new programmed function:
 - Overload LED off: Operation function;
 - Overload LED on: No Fault function.

5. PROGRAMMING INFORMATION AND SUGGESTIONS

This chapter helps the user to set the types of starting controls according to their applications.

5.1 APPLICATIONS AND PROGRAMMING



ATTENTION!

Suggestions and important notes for each type of starting control.



ATTENTION!

To know the correct programming of the parameters, have your load data on hand and use the WEG (Soft-Starter) Dimensioning Software available at WEG's home page (<http://www.weg.net>).

If you are unable to use the software mentioned above, you can follow some practical concepts described in this chapter.

Shown below are some characteristic curves with current and starting torque behavior according to some kinds of control.

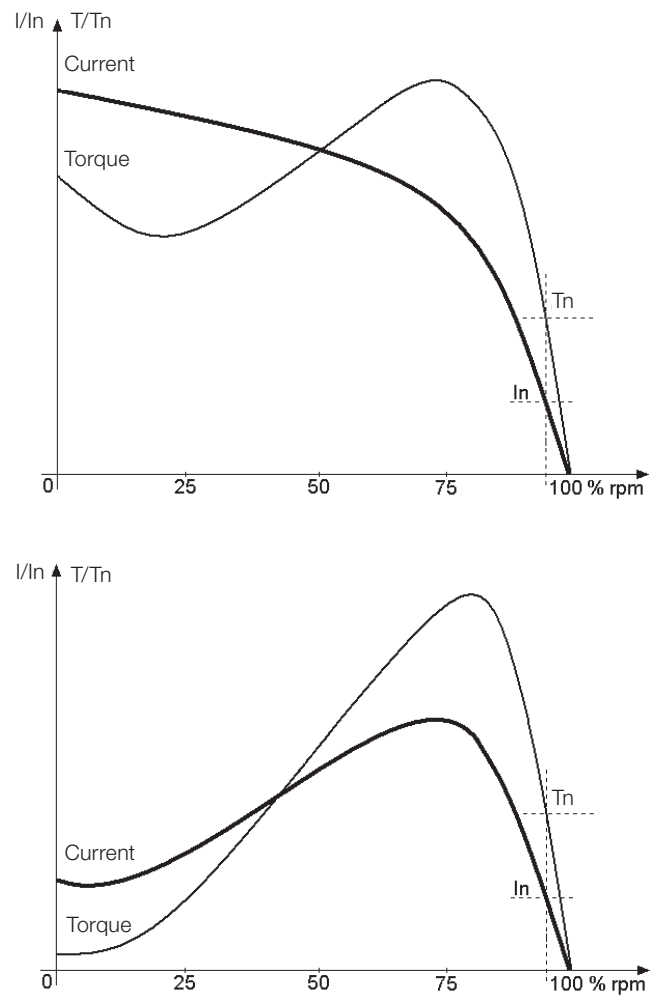

Figure 5.1: Characteristic curves of torque and current in a direct on-line start and by voltage ramp

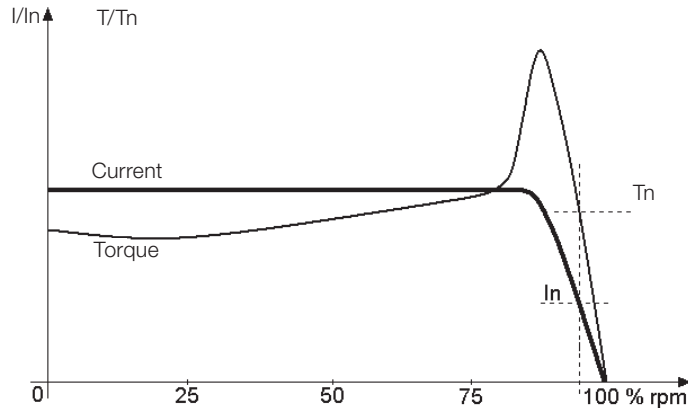

Figure 5.2: Characteristic curves of torque and current in a current limitation start

The following items show characteristic curves with the starting torque behavior according to some types of loads and their suggested controls.

5.1.1 Voltage Ramp Starting

5

- 1) Set the value of the initial voltage to a low value;
- 2) When a load is applied to the motor, set the initial voltage to a value that makes the motor rotate smoothly from the instant it is started.
- 3) Set the acceleration time with the necessary start time, initially with short times, 10 to 15 seconds, and afterwards try to find the best starting condition for the used load.

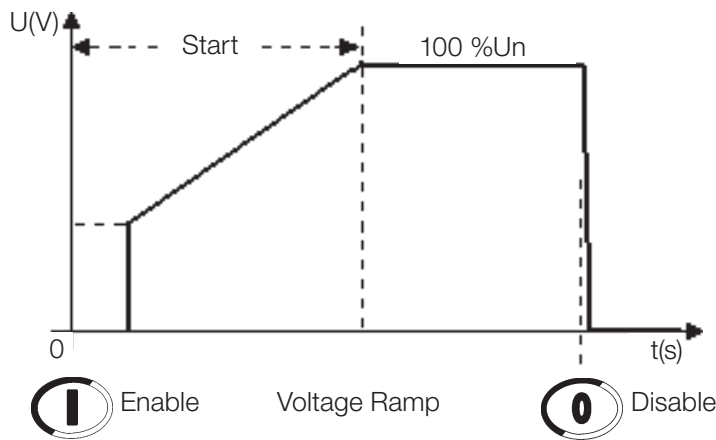

Figure 5.3: Voltage ramp starting



NOTE!

- With long starting times, or when the motor is without a load, vibration can occur during the start of the motor, therefore lower the starting time;
- If faults occur during the start, check all the connections from the Soft-Starter to the supply network, motor connections, supply network voltage levels, fuses and circuit breakers.

5.1.2 Current Limit Starting

- 1) To start with a current limitation it is necessary to start with a load. Initial test without load can be done with a voltage ramp;
- 2) Set the acceleration time with the necessary starting time, initially with short times, 15 to 20 seconds. This time will be used as the stall time in case the motor does not start;
- 3) Set the current limit according to the conditions that your electric installation allows, as well as to the values that supply enough torque to start the motor. It can initially be programmed with values between 2x and 3x the nominal current of the motor (I_n of the motor).

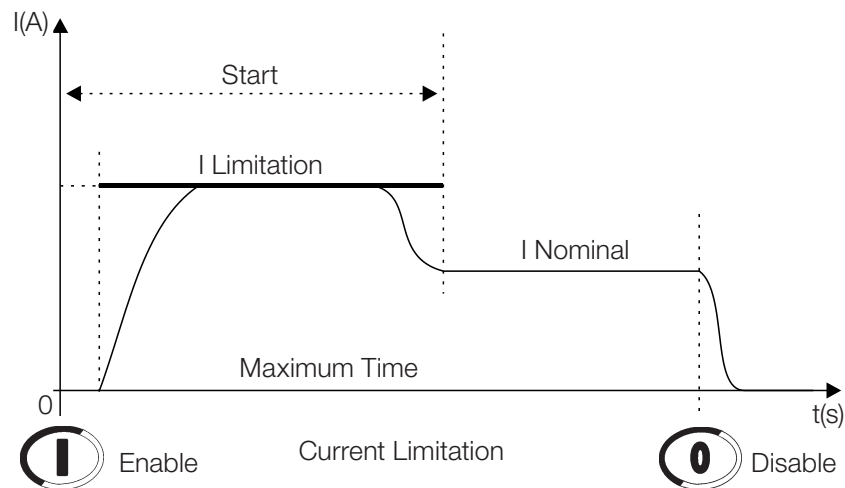

Figure 5.4: Current limit starting



NOTE!

- If the current limit is not reached during the start, the motor will start immediately;
- Very low Current Limit values do not provide sufficient torque to start the motor. Always keep the motor rotating once it is started.
- For loads that need a higher initial starting torque, the Kick Start function can be used;
- If faults occur during the start, check all the connections from the Soft-Starter to the supply network, motor connections, supply network voltage levels, fuses and circuit breakers.

5.1.3 Starting with Pump Control (P202 = 2)

- 1) To start with pump control a load is necessary. No-load tests can be done with voltage ramp;
- 2) The starting parameters setting depend mainly on the types of hydraulic installations. Thus we recommend optimizing factory settings, if possible.
- 3) Check if the motor rotation direction is as indicated on the pump frame. If not, connect the phase sequence as indicated at P620;

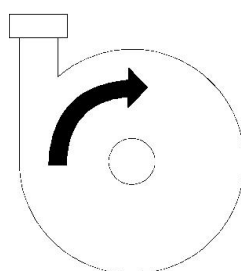

Figure 5.5: Direction of rotation of a hydraulic centrifugal pump

- 4) Set the initial voltage - P101 – so the motor starts smoothly as soon as it is enabled.
- 5) Set the acceleration time according to the application, and, that the motor is able to start the load smoothly, but the required acceleration is not exceeded. If acceleration times are set too long, this may result in vibration or harmful motor overheating;
- 6) To check the correct starting process, always use a manometer in the hydraulic installation. Pressure increase should not result in sudden oscillations. Thus the pressure increase should be as linear as possible;

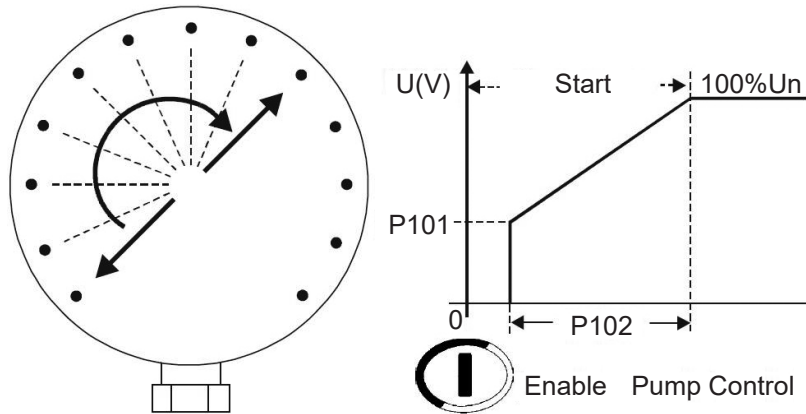

Figure 5.6: Manometer showing pressure increase

5

- 7) Program the deceleration initial voltage (P103) only when no pressure drop is detected at the deceleration begin. With this deceleration initial voltage you can improve the linear pressure drop during the deceleration;
- 8) Set the deceleration time according to the application, and, ensuring that the pump stops smoothly within the expected limits. The set of excessively long times may result in vibrations or harmful motor overheating;

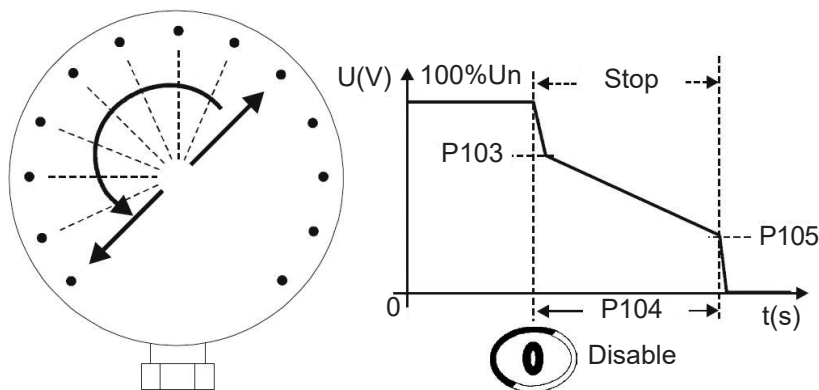

Figure 5.7: Manometer showing the pressure drop

- 9) Generally, the current increases at the end of the deceleration ramp and in this case the motor requires more torque to achieve a smooth water flow stop. When the motor has already stopped, but is still enabled, the current will increase too much. To prevent this condition, set P105 to a value that as soon it stop it is also disabled;
- 10) Set P610 and P611 to current and time levels that prevent the hydraulic pump from running without a load.

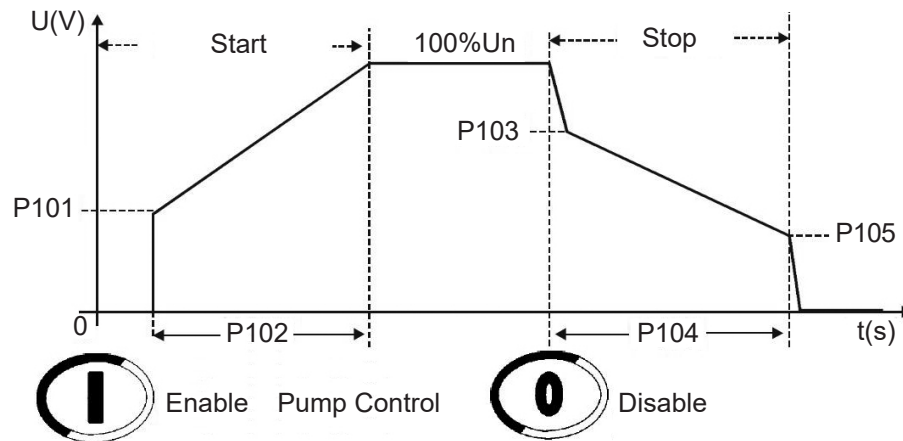

Figure 5.8: Start with pump control



NOTES!

1. If the hydraulic piping is not fitted with a manometer, the water hammer can be noted at the pressure relief valves;
2. Please, consider that sudden line voltage drops results in motor torque drops. Thus, ensure that the power supply line characteristics are within the characteristics required for motor operation;
3. If errors are detected during the motor start, check all connections of the Soft-Starter to the power line, the motor connections, the voltage levels of the power line, the fuses, circuit-breakers and disconnecting switches.

5.1.4 Programming the control type in pump control

Is recommended program the control type in pump control using keypad or serial communication, see the Programming Manual for more details. In special cases, when is not available keypad or serial communication, is also possible to program the control type in pump control following these instructions:

- 1) To enter in programming mode, keep the reset key at the SSW-08 front cover pressed during 5 seconds, keeping it also pressed throughout the programming;
- 2) When in the programming mode, LEDs will turn on indicating the actual parameterization. See item 4.10 and 4.12;
- 3) To modify the control type, change the Stall DIP Switch and put it back in the previous position. The Stall LED will indicate the new programmed control type:
 - LED Stall off: P219=0. Control type defined through Voltage Ramp/Current Limit DIP Switch.
 - LED Stall on: P219=2. Control type in Pump Control and parameterization through Trimpots and DIP Switches.

5.2 PROTECTIONS AND PROGRAMMING

5.2.1 Suggestion on How to Program the Thermal Class

For each application exists a range of thermal classes, which might be set. The overload protection should not trip during normal starting. Therefore it is necessary to know the starting time and current, to determine the minimum thermal class. The maximum thermal class depends on the motor limit.

Determine the minimum thermal class:

- 1) Initially start at the standard thermal class, sometimes, but without the motor overheating;
- 2) Determine the correct starting time and find an average of the current using a multimeter with a current probe to measure it; A current average can be found for any type of starting control;

For example:

Starting an 80 A motor using a voltage ramp. The current starts at 100 A and goes to 300 A, returning afterwards to the nominal value in 20 seconds.

$$(100 \text{ A} + 300 \text{ A})/2 = 200 \text{ A}$$

$$200 \text{ A}/80 \text{ A} = 2.5 \times \text{In of the motor}$$

Therefore: 2.5 x In @ 20 seconds.

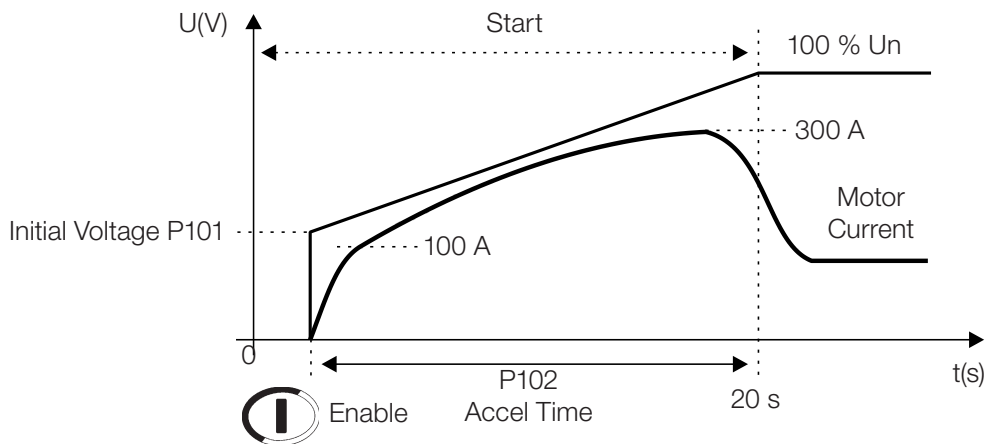

Figure 5.9: Typical current curve during a voltage ramp start

- 3) Use this time to find the minimum class necessary to start the motor in cold condition. In the item 4.8 Overload Protection it is possible to check the thermal class curves of the motor in cold condition.

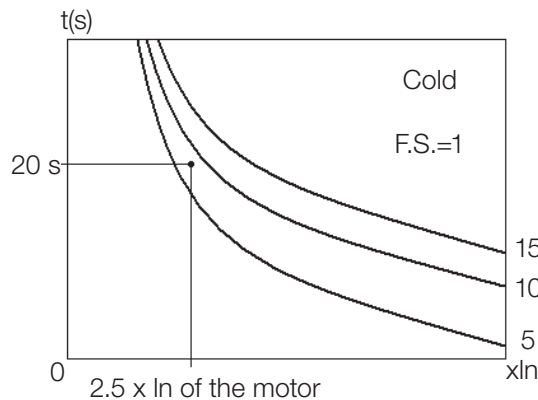

Figure 5.10: Checking the minimum class of curves in cold condition

Therefore the minimum class necessary to start the cold motor is Class 10. Class 5 will trip during starting.



NOTE!

If the motor must start in the hot condition, class 10 will trip during the second start. In the case a higher thermal class must be set.

Determine the maximum thermal class:

To correctly program the Thermal Class that will protect your motor it is essential to have in hand the motor locked rotor current and locked rotor time. This information is available in the motor manufacturer's catalogue. Put these values into figure 4.8, in case of the cold stall time or into figure 4.9, in case of hot stall time.

For example:

Stall Current = $6,6 \times I_n$

Hot Stall Time = 6s

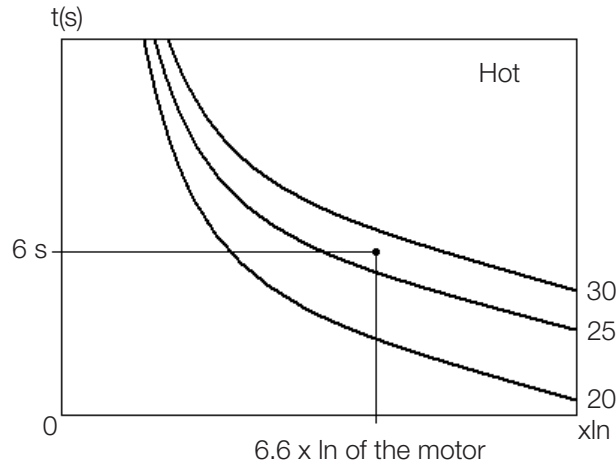

Figure 5.11: Checking the maximum class of curves in hot condition

Class 25 is the highest class that protects the motor.



NOTE!

Remember that this protection has as a standard the Three Phase IP55 Standard WEG Motor, therefore if your motor is different, then do not program the thermal class to its maximum, instead, program it near its minimum thermal class to start.

Example of how setting the thermal class:

Motor data:

Power: 50 hp

Voltage: 380 V

Nominal Current (I_n): 71 A

Service Factor (S.F.): 1.00

I_p/I_n : 6.6

Stall time: 12 s in hot condition

Speed: 1770 rpm

Motor + load starting data:

Starting by Voltage Ramp, starting current average:

3 x the nominal current of the motor during 17 s (3 x In @ 17 s).

1) In the graph, figure 4.8 in cold condition, one can see the minimum Thermal Class that will allow the start with a reduced voltage:

For 3 x In of the motor @17 s, the next highest is adopted: Class 10.

2) In the graph, figure 4.9 in hot condition, one can see the maximum Thermal Class that the motor can stand due to the stall time in hot condition:

For 6.6 x In of the motor @ 12 s, the next lowest is adopted. Class 30.

One now knows that Thermal Class 10 allows a start and Thermal Class 30 is the maximum limit. Thus, a Thermal Class between the two should be adopted, according to the quantity of starts per hour and the interval of time between Off/On procedures the motor.

The closer to Class 10, the more protected the motor will be, the fewer the starts per hour and the greater the interval of time must be between Off/On procedures the motor.

The closer to Class 30, the closer it gets to the maximum limit of the motor, thus there can be more starts per hour and lower intervals of time between Off/On procedures the motor.

5

5.2.2 Service Factor

When the Service Factor (S.F.) is different from 1.00 and if there is the need to use it in the application, this must be considered in the setting of the overload protection. To avoid tripping of the overload protection, when the service factor is used, the nominal motor current set at the SSW08 must be readjusted. If an acessorie with parameter access is used, the service factor can be set directly in the P406, avoiding the readjustment of the nominal current.

Example of readjustment of the nominal current:

- I_{SSW08} = 30 A
- I_{MOTOR} = 25 A
- S. F. = 1.15

Setting of the Motor Current = $I_{MOTOR} \times S.F. / I_{SSW08} = 25 A \times 1.15 / 30 A = 96\%$



ATTENTION!

The increased motor current has direct impact on the maximum thermal class, that protects the motor, even if the S.F. parameter is set.

Determine the maximum thermal class, considering the service factor:

Stall Current = $6.6 \times I_n$

Hot Stall Time = 6s

Service Factor = 1.15

Before the maximum thermal class is verified in figure 4.9, the stall current must be divided by the service factor.

$$\text{Stall Current} / \text{S.F.} = 6.6 / 1.15 = 5.74$$

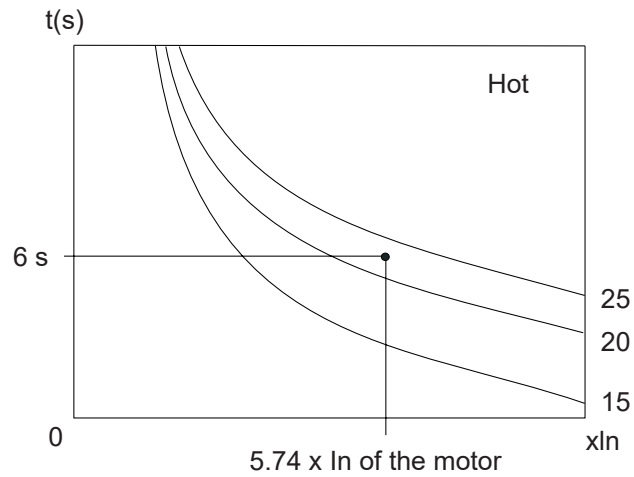

Figure 5.12: Checking of the maximum thermal class, considering the S.F.

Class 20 is the highest class that protects the motor, if the service factor is used.

6. SOLUTION AND TROUBLESHOOTING

6.1 FAULTS AND POSSIBLE CAUSES

When a fault is detected, the Soft-Starter is disabled and the Fault Code is displayed by flashing LEDs.

To restart the Soft-Starter after a fault has occurred it must be reset. In general, resetting can be done as follows:

- Disconnecting and reapplying the AC power (power-on RESET);
- Pressing the “RESET” key in the SSW-08 front panel (RESET key);
- Automatically by the automatic RESET. Enable this function via DIP Switch (auto);
- Via digital input DI2 or DI3.

Table 6.1: Faults and possible causes

Protection Description and Fault Display	Activation Description	Probable Causes	Reset
Phase loss or Undercurrent E03 (LED Phase Loss) Flashing	At starting: It occurs when there is no voltage in the power supply terminals (R/1L1, S/3L2 and T/5L3) or when the motor is disconnected. With the motor running: It trips when the current stays below the programmed value longer than the programmed time. Referring to the nominal motor current. When the parameters are set with the factory default values, then this protection trips after elapsing 1 second with phase loss either at the input or at the output (motor). It trips when the current circulating through the SSW-08 is less than 20 % of the value adjusted at the Motor Current trimpot.	Percentage values programmed as maximum acceptable limit. In hydraulic pump applications, it may be running with no load. Phase loss in the three-phase network. Short-circuit or fault at the thyristor or By-pass. Motor not connected. Motor connection is incorrect Loose contact in the connections. Starting problems with the input contactor. Input fuses are blown. Undersized input transformer. Incorrect programming of the Motor Current trimpot. Motor current consumption lower than required for phase loss protection to work.	Power-on. Reset key. Auto-reset. DIx.
Over temperature in the power section E04 (LED Fault) Flashes once (LED Ready) On	When the heatsink temperature is superior to the limit. Also trips when the temperature sensor is not connected. When the time limits given by the time x temperature curves of SCR protection are exceeded.	Shaft load too high. Elevated number of successive starts. Internal temperature sensor not connected.	Power-on. Reset key. Auto-reset. DIx.

6

Table 6.1: Faults and possible causes (cont.)

Protection Description and Fault Display	Activation Description	Probable Causes	Reset
Electronic motor overload E05 (LED Overload) Flashing	When the times given by the programmed thermal class curves exceed the limit.	Incorrect setting of the “Motor Current” trimpot (motor current set). The set value is too low for the motor being used. Starting sequence greater than allowed. Programmed thermal class too low. Time between Off/On procedures lower than that permitted by the motor power refrigeration time. Load on the motor shaft too high. Thermal protection value saved when the control is turned off and brought back when turned back on.	Power-on. Reset key. Auto-reset. Dlx.
Short circuit in the SSW power E19 (Fault LED) Flashes 7 times (Ready LED) is off	When the current value in one of the phases is above 30% of the Soft-Starter rated current with the motor stopped, that is, without the Run command.	Short circuit in some thyristor or relay of internal by-pass. External short circuit in parallel with the Soft-Starter power. Defect in the current analog reading.	Power-on. Manual. Reset. Reset key. Dlx.
Start timeout during current limit starting E62 (LED Fault) Flashes twice (LED Ready) On	When the starting time is longer than the time set in the acceleration ramp trimpot. Active only with current limit starting.	Programmed time for the acceleration ramp inferior to what is needed. Value of the programmed current limitation too low. Motor locked, rotor blocked.	Power-on. Reset key. Auto-reset. Dlx.
Stall E63 (LED Stall) Flashing	Activates before full voltage, if the current is greater than twice the nominal motor current.	Programmed acceleration ramp time lower than the actual acceleration time. Motor shaft is locked The transformer that supplies the motor can be saturating and taking too much time to recover from the starting current.	Power-on. Reset key. Auto-reset. Dlx.
Overcurrent E66 (LED Overcurrent) Flashing	It is only monitored when the SSW-08 is at full voltage. When the parameters are set with the factory default values this protection trips when the motor current exceeds 3 times the value adjusted in the trimpot (Motor Current) for a time longer than 1 second.	Short-circuit between phases. Momentary motor overload. Motor shaft is locked, rotor blocked.	Power-on. Reset key. Auto-reset. Dlx.
Incorrect phase sequence E67 (LED Phase Seq.) Flashing	When the sequence of synchronism signals interruptions does not follow the RST sequence.	Network phase sequence inverted at the input. May have been changed in another place of the supply network. Motor connection is incorrect.	Power-on. Reset key. Dlx.

Table 6.1: Faults and possible causes (cont.)

Protection Description and Fault Display	Activation Description	Probable Causes	Reset
<p>Undervoltage in the control supply</p> <p>E70</p> <p>(LED Fault) Flashes twice (LED Ready) Off</p>	<p>Activates when the control supply voltage is lower than 93 Vac.</p>	<p>Electronics supply lower than the minimum value.</p> <p>Electronics power supply with loose contact.</p> <p>Electronics power supply fuse blown.</p>	<p>Power-on. Reset key. Auto-reset. Dlx.</p>
<p>Internal By-pass relay contact Open</p> <p>E71</p> <p>(LED Fault) Flashes 3 times (LED Ready) Off</p>	<p>When there is a fault with the internal By-pass relay contacts at full voltage.</p>	<p>Loose contact in the starting cables of the Internal By-pass relays.</p> <p>Defective By-pass relay contacts due to an overload</p> <p>Incorrect electronic supply voltage, only for SSW-08 models 255-412 A</p>	<p>Power-on. Reset key. Auto-reset. Dlx.</p>
<p>Overcurrent before the By-pass</p> <p>E72</p> <p>(LED Fault) Flashes 4 times (LED Ready) Off</p>	<p>Activates before the closing of the By-pass if the current is greater than: 37.5 A for the SSW models up to 30 A; 200 A for the SSW models from 45 to 85 A; 260 A for the SSW model of 130 A; 400 A for the SSW models from 171 and 200 A. 824 A for the models from 255 A to 412 A.</p>	<p>The time programmed for the acceleration ramp is shorter than the actual acceleration time.</p> <p>Nominal motor current higher than the current that can be supported by the Soft-Starter.</p> <p>Motor shaft is locked, rotor blocked.</p>	<p>Power-on. Reset key. Auto-reset. Dlx.</p>
<p>Frequency out of tolerance</p> <p>E75</p> <p>(LED Fault) Flashes once (LED Ready) Off</p>	<p>When the limit is higher or lower than the limits of 45 to 66 Hz.</p>	<p>The line frequency is out of range.</p> <p>When the Soft-Starter + motor are being supplied by a generator that is not supporting the full load or the start of the motor.</p>	<p>Power-on. Reset key. Auto-reset. Dlx.</p>

Protection Description and Fault Display	Activation Description	Probable Causes	Reset
Closed By-pass contact or shorted SCR's E77 (Fault LED) flashes 6 times (Ready LED) Off	When the SSW-08 does not detect voltage difference between the input and output at the moment the motor is switched off.	Bad contact in the relay cables. By-pass contacts are welded. Short-circuit Thyristor. Input and output external short-circuit. Disconnected motor.	Power-on. Manual reset Reset key. Dlx.

NOTE!
 In the case of E04 (over temperature), it is necessary to wait a little before resetting, in order to cool down.
 In the case of E05 (motor overload), it is necessary to wait a little before resetting, in order to cool down.

6.2 TROUBLESHOOTING

Table 6.2: Solving the most frequent problems

Problem	Points to check	Corrective action
Motor does not run	Wrong wiring	Check all the power and command connections. For example: The Dlx digital inputs programmed as enabling or external fault must be connected to AC supply.
	Wrong programming	Check if the parameters are with the correct values for the application.
	Fault	Check if the Soft-Starter is not blocked to a detected fault condition.
Motor does not reach nominal speed	Motor stall	Increase the current limit level with the control to limit the current (refer to table 6.1).
Motor rotation oscillates (fluctuates)	Loose connections	Switch the Soft-Starter and the power supply off and tighten all the connections. Check all the internal connections of the Soft-Starter to make sure they are well connected.
Motor rotation: Too high or too low	Motor nameplate data	Check if the motor used is in accordance to the application.
LEDs off	Check the power supply voltage of the control board (A1 and A2)	Nominal values must be inside the following limits: Umin. = 93.5 Vac Umax.= 264 Vac
Vibration during acceleration	Soft-Starter Settings	Reduce the acceleration ramp time. Reduce the pedestal voltage setting.



NOTE!

When contacting WEG for service or technical assistance, please have the following data on hand:

- Model of the Soft-Starter;
- Serial number, production date and hardware revision present in the identification label of the product (refer to item 2.3);
- Installed software version (refer to item 2.3);
- Application and programming data.

For explanations, training or service, please contact WEG Automação Service Department.

6.3 PREVENTIVE MAINTENANCE



WARNING!

Always disconnect the general power supply before touching any electric component associated to the Soft-Starter SSW-08.

**Do not apply any high voltage tests on the Soft-Starter SSW-08!
If necessary, consult the manufacturer.**

Do not use megometers to test thyristors.

6

Periodic inspections of Soft-Starters SSW-08 and installations are necessary to avoid operating problems due to unfavorable environmental conditions like high temperature, moisture, dust, vibrations or due to the aging of the components.

When the SSW-08 Soft-Starter is stored for a long period of time, it is recommended that it be energized for 1 hour, each year.

Table 6.3: Periodic inspections after putting into use

Component	Abnormality	Corrective Action
Terminals, Connectors	Loose screws	Tightening ⁽¹⁾
	Loose connectors	
Fans / Ventilation Systems	Dirty fans	Cleaning ⁽¹⁾
	Abnormal noise	Substitute fan
	Fan always off	
	Abnormal vibration	
	Dust in the air filters	Cleaning or substitution ⁽²⁾
Power Module / Power Connections	Accumulated dust, oil, moisture, etc.	Cleaning ⁽¹⁾
	Screws with loose connections	Tightening ⁽¹⁾

(1) Every six months.

(2) Twice a month.

7. OPTIONS AND ACCESSORIES

This chapter describes the optional devices that can be used with Soft-Starter SSW-08.

Table 7.1: Optional description

Optional Description	WEG Part Number
Plug-in Local Keypad	10935572
Remote Keypad Kit (Cable not included)	10885878
Remote Keypad + RS-485 Kit (Cable not included)	12368332
1m SSW-08 - Remote HMI Connection Cable	10050268
2m SSW-08 - Remote HMI Connection Cable	10190951
3m SSW-08 - Remote HMI Connection Cable	10211478
5m SSW-08 - Remote HMI Connection Cable	10211479
7,5m SSW-08 - Remote HMI Connection Cable	10050302
10m SSW-08 - Remote HMI Connection Cable	10191029
Plug-in Kit for DeviceNet Communication	10935681
Plug-in Kit for RS-232 Communication	10935578
3m RS-232 Connection Cable	10050328
10m RS-232 Connection Cable	10191117
Plug-in Kit for RS-485 Communication	10935573
Ventilation Kit for Size 2 (Currents from 45 to 85 A)	10935650
Ventilation Kit for Size 3 (Currents from 130 to 200 A)	10935559
IP20 Kit for Size 3 (Currents from 130 to 200 A)	10935651
Plug-in Kit for Motor PTC	10935663
SuperDrive G2 Kit	10945062
IP20 kit for size 4 (currents from 255 to 412A)	11059230



NOTE!

Please, check the availability of the accessories.

7.1 IP20 KIT

The IP20 KIT is used to protect against touching the energized parts.

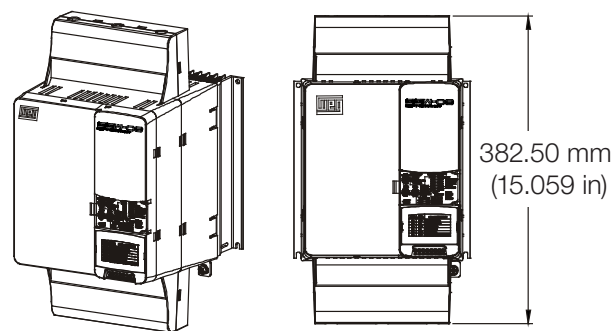

Figure 7.1: IP20 kit for size 3

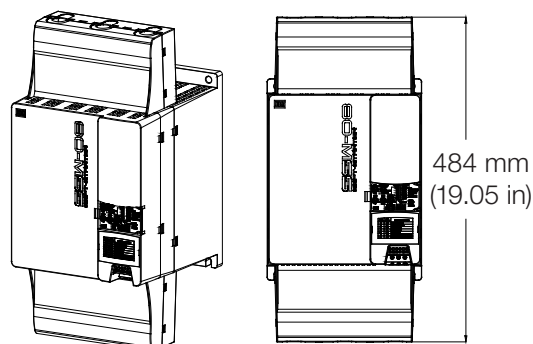

Figure 7.2: IP20 kit for size 4

8. TECHNICAL CHARACTERISTICS

This chapter describes the electric and mechanical technical characteristics of the Soft-Starter SSW-08 line.

8.1 NOMINAL POWERS AND CURRENTS ACCORDING TO UL508

Table 8.1: Powers and currents according to UL508, room temperature of 55 °C (131 °F)

SSW-08 Model	Motor voltage 220/230 V		Motor voltage 380/400 V		Motor voltage 440/460 V		Motor voltage 575 V	
	(Hp)	(kW)	(Hp)	(kW)	(Hp)	(kW)	(Hp)	(kW)
17 A	5	3.7	7.5	5.5	10	7.5	15	11
24 A	7.5	5.5	10	7.5	15	11	20	15
30 A	10	7.5	15	11	20	15	25	18.5
45 A	15	11	25	18.5	30	22	40	30
61 A	20	15	30	22	40	30	50	37
85 A	30	22	50	37	60	45	75	55
130 A	50	37	75	55	100	75	125	90
171 A	60	45	100	75	125	90	150	110
200 A	75	55	100	75	150	110	200	150
255 A	100	75	150	110	200	150	250	185
312 A	125	90	175	130	250	185	300	225
365 A	150	110	200	150	300	225	350	260
412 A	150	110	250	185	350	260	400	300

8.2 NOMINAL POWERS AND CURRENTS FOR STANDARD IP55, IV POLE WEG MOTOR

Table 8.2: Powers and currents for WEG motors, room temperature of 55 °C (131 °F)

SSW-08 Model	Motor voltage 220/230 V		Motor voltage 380/400 V		Motor voltage 440/460 V		Motor voltage 525 V		Motor voltage 575 V	
	(Hp)	(kW)	(Hp)	(kW)	(Hp)	(kW)	(Hp)	(kW)	(Hp)	(kW)
17 A	6	4.5	10	7.5	12.5	9.2	15	11	15	11
24 A	7.5	5.5	15	11	15	11	20	15	20	15
30 A	10	7.5	20	15	20	15	25	18.5	30	22
45 A	15	11	30	22	30	22	40	30	40	30
61 A	20	15	40	30	50	37	50	37	60	45
85 A	30	22	60	40	60	45	75	55	75	55
130 A	50	37	75	55	100	75	125	90	125	90
171 A	60	45	125	90	125	90	150	110	175	132
200 A	75	55	125	90	150	110	200	150	200	150
255 A	100	75	175	132	200	150	250	185	250	185
312 A	125	90	200	150	250	185	300	220	300	225
365 A	150	110	250	185	300	225	350	260	400	300
412 A	150	110	300	220	350	260	440	315	450	330



NOTE!

The maximum powers indicated in table 8.1 are based on 3 x nominal current of Soft-Starter SSW-08 during 20 s and 10 starts per hour (3xIn @ 20 s).

8.3 POWER DATA

Power Supply	Power Voltage (R/1L1, S/3L2, T/5L3)	(220 to 575) Vac (-15 % to +10 %), or (187 to 632) Vac
	Frequency	(50 to 60) Hz (± 10 %), or (45 to 66) Hz
Capacity	Maximum number of starts per hour (without ventilation)	10 (1 every 6 minutes; models from 17 A to 30 A and 255 A to 412 A) 3 (1 every 20 minutes; models from 45 A to 200 A)
	Maximum number of starts per hour with optional ventilation Kit	10 (1 every 6 minutes; models from 45 A to 200 A)
	Start cycle	3 x In of the SSW-08 during 20 seconds
Thyristors (SCRs)		Reverse voltage with 1600 V maximum peak
Overvoltage category		III (UL508/EN61010)

8.4 ELECTRONICS AND PROGRAMMING DATA

Power Supply	Control voltage Connector (A1, A2)	<ul style="list-style-type: none"> ■ (110 to 240) Vac (-15 % to +10 %), or (94 to 264) Vac, models from 17 A to 200 A ■ (110 to 130) Vac or (208 to 240) Vac (-15 % to +10 %) models from 255 A to 412 A.
	Frequency	<ul style="list-style-type: none"> ■ (50 to 60) Hz (± 10 %), or (45 to 66) Hz
	Consumption	<ul style="list-style-type: none"> ■ 15 VA models from 17 A to 200 A ■ 45 VA Continuous ■ 530 VA additional during by-pass Closing (models from 255 A to 412 A).
Control	Method	<ul style="list-style-type: none"> ■ Voltage ramp; ■ Current limitation.
Inputs	Digitals	<ul style="list-style-type: none"> ■ 3 Isolated digital inputs; ■ Minimum upper level: 93 Vac; ■ Maximum lower level: 10 Vac; ■ Maximum voltage: 264 Vac; ■ Input current: 1.47 mA @ 220 V; ■ Programmable functions.
Outputs	Relay	<ul style="list-style-type: none"> ■ 2 relays with NO contacts, 240 Vac, 1 A, and programmable functions.
Safety	Protections	<ul style="list-style-type: none"> ■ Overcurrent; ■ Phase loss; ■ Inverted phase sequence; ■ Heatsink overtemperature; ■ Motor overload; ■ External fault; ■ Open By-pass contact; ■ Closed By-pass contact; ■ Overcurrent before By-pass; ■ Stall; ■ Frequency out of range; ■ Electronic supply undervoltage.

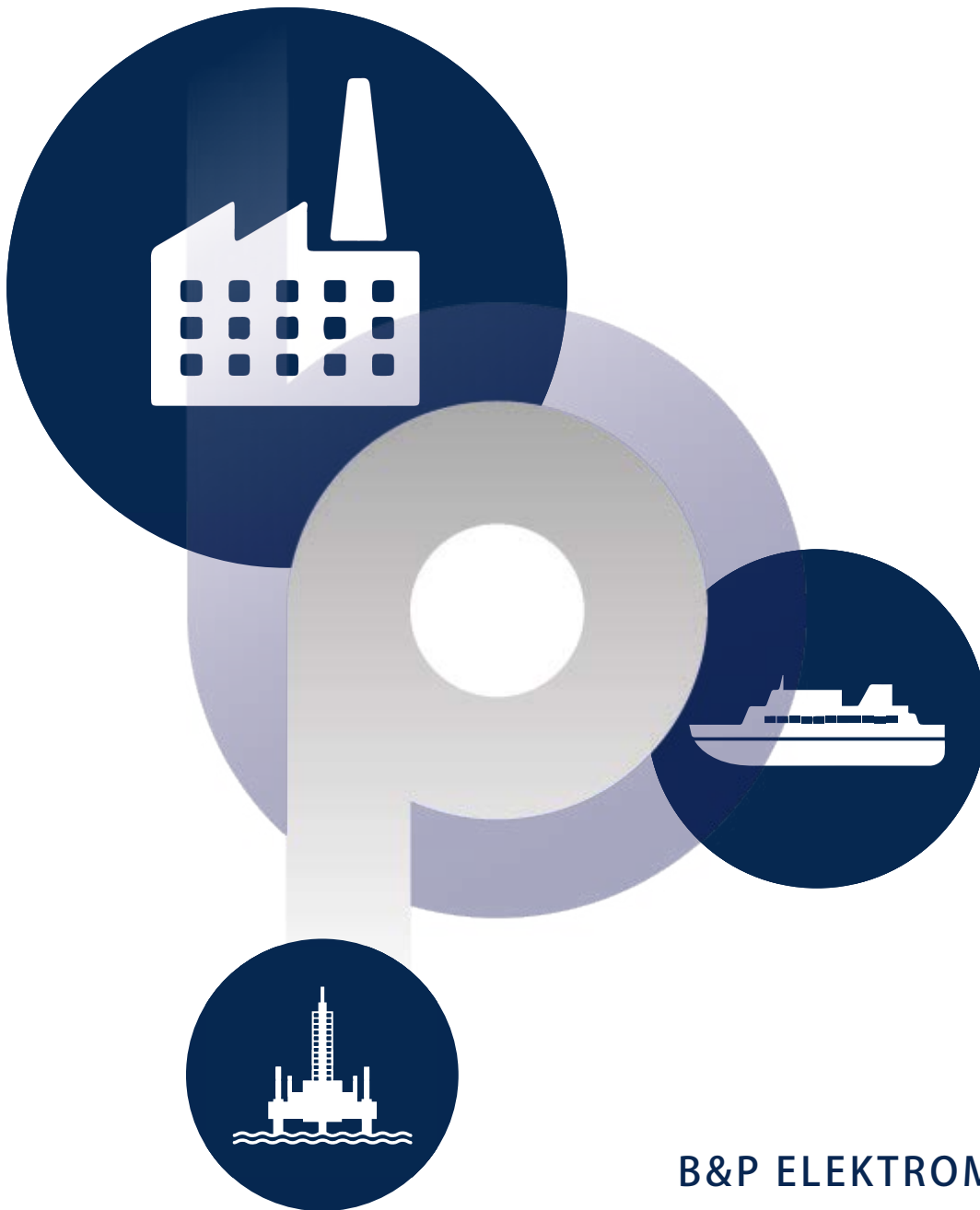

B&P ELEKTROMOTOREN BV

Expeditiweg 21
6657 KM Boven-Leeuwen

info@bnpelektromotoren.nl

+31 (0)344 616 267

BTW nr. NL819113918B01

KvK nr. 30237800

ING Bank NL60 INGB 0675 304 792



www.bnpelektromotoren.nl