

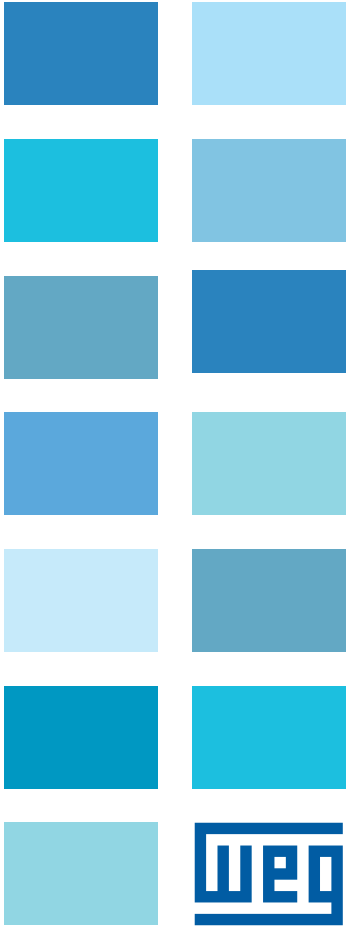

W22 Brake Motor

Three-phase Electric Motor

European Market

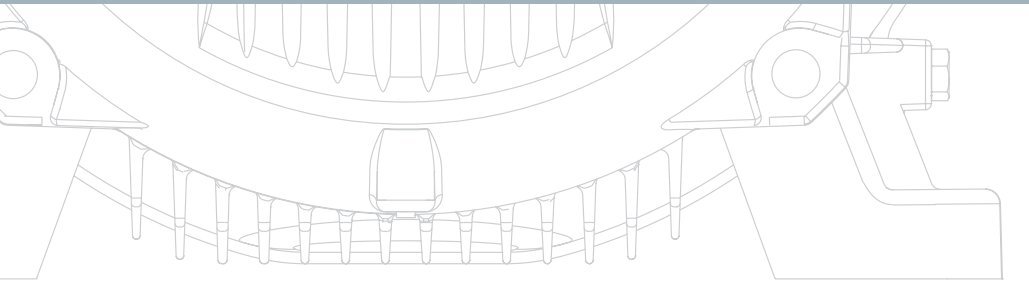
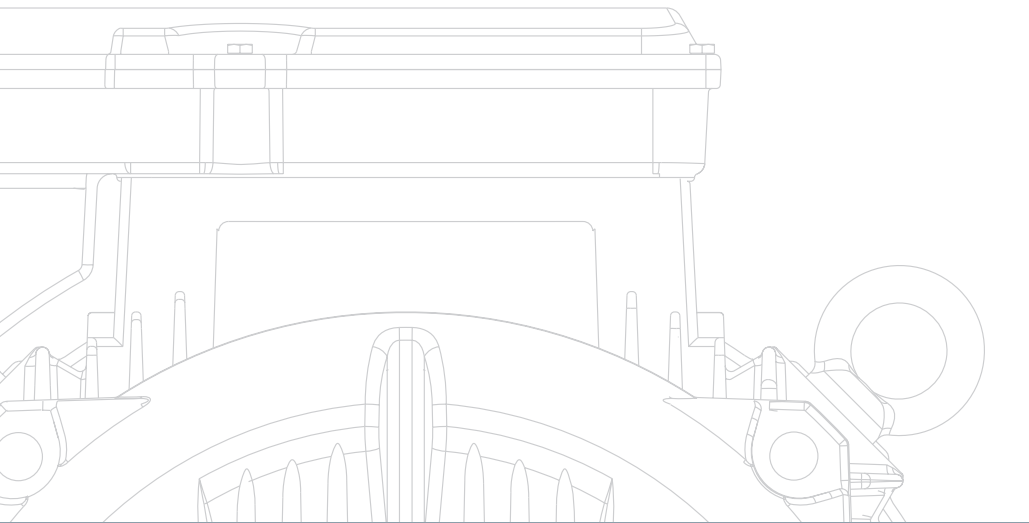

Visual index

Main motor parts



Main brake parts

1	Fastening screw	6	Retaining ring
2	Release lever	7	Hub
3	Brake stator (electromagnet)	8	Key
4	Brake disc	9	Sealing system
5	Brake seal	10	ND-endshield

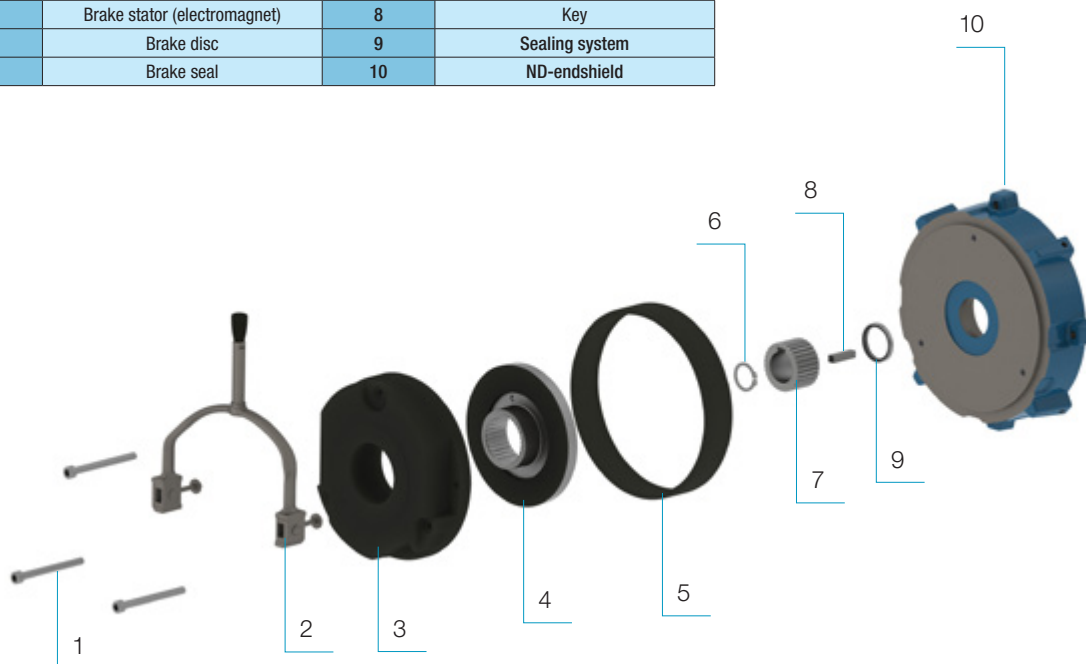

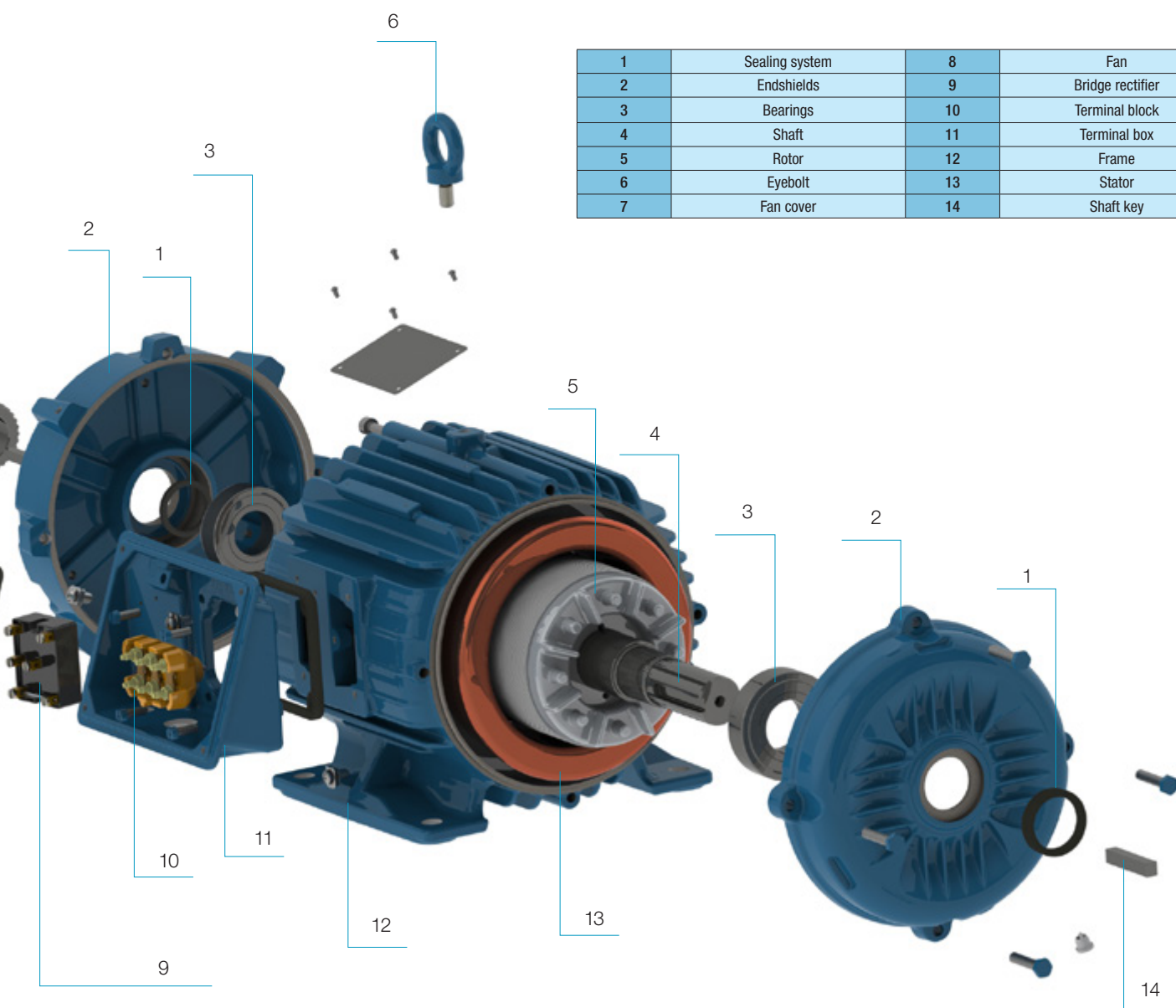

1	Sealing system	8	Fan
2	Endshields	9	Bridge rectifier
3	Bearings	10	Terminal block
4	Shaft	11	Terminal box
5	Rotor	12	Frame
6	Eyebolt	13	Stator
7	Fan cover	14	Shaft key



W22 Brake Motor

In order to obtain productivity and high performance, a company must count on reliable equipment, operating in accordance with its purpose.

That is the essence of the W22 Brake Motor:

Provide the production process with synergy and agility.

Featuring a braking system with high torque and durability, the W22 Brake Motor is ideal for equipment that requires fast stops for safety, accurate positioning and time saving.

The W22 Brake Motor introduces characteristics in the braking system and platform, which counts on the same innovative features that make the W22 line a great success:

- Frame structure that reduces air dispersion and improves the cooling
- Terminal box with greater internal space and easy handling
- Solid feet that simplify the motor alignment and installation
- Frame providing high mechanical strength and low vibration levels

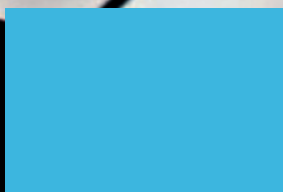

Features

Standard

- Rated output: 0,12 kW to 75 kW
- Number of Poles: 2 to 8
- Frame size: 63 to 250S/M
- Frequency: 50 Hz
- Voltage:
 - 220-240/380-415 V (frames 63 to 100L)
 - 380-415/660 V (frames 112M and 250S/M)
- Brake power supply: 220-240 V
- Normally closed brake
- Design: N
- Insulation class: F (DT 80K)
- Degree of protection: IP55
- Mounting: B3T
- Cooling method: TEFC (Totally Enclosed Fan-Cooled) - IC411
- Frame and terminal box material: Cast iron FC-200
- Fan material: Plastic
- Shaft material: AISI 1040/45
- Ball bearings
- DE bearing seal:
 - Vring (frames 63 to 200L)
 - WSeal® (frames 225S/M and 250S/M)
- NDE bearing: Lip seal
- Painting plan: 207A (frames 63 to 132M/L) and 203A (from frame 160M and up), classified as corrosion category C2, according to ISO 12944:2

Optional

- Mounting: B35, B5, V1, V3, V6, among others.
- Degree of Protection: IP56, IP65, IP66
- Frequency: 60 Hz
- DE bearing seal: W3 Seal, taconite seal, INPRO/SEAL®
- Vibration level: Degree B
- Winding thermal protection: thermostat or thermistor
- Space heater
- Cable gland
- Drip cover
- Tropicalized internal painting
- Encoder (from frame 90S and up)
- Stainless steel screws
- Cooling method: TEBC – Totally enclosed blower cooled (IC 416)
- Insulation class: “H”
- Able to operate with frequency inverter*
- Manual brake release (up to frame 200L)**
- Microswitch to monitor the air gap or brake opening (from frame 100L up)
- Brake power supply:
 - 380-415 V
 - 440-480 V
- Additional terminal box for frames 160M to 250S/M

*For motors able to operate with frequency inverter, WEG recommends the use of thermal protection on the winding.

**Not available for frames 63 to 80 with terminal box on top.

Ideal for applications that require immediate, accurate and safe stops, position control and energy saving.

The W22 Brake Motor is suitable for many different applications, such as load elevators, hoists, shears, machining equipment, looms, packaging machines, conveyors, washing and bottling machines, bending machines, among others.

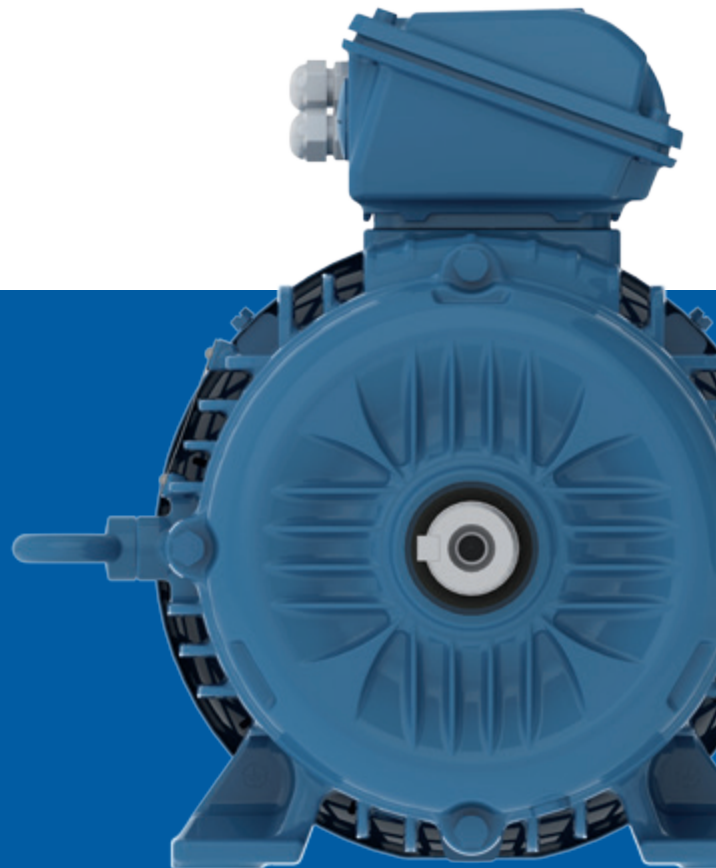

Optimisations of the braking system

Brake

- The friction element of the brake provides less wear and more safety
- According to platform of world class brake models (interchangeable)
- Guarantee of fast and accurate brakes
- System with fewer moving parts reduces downtime for maintenance

Manual release lever (optional)

- Motor shaft may remain free in emergency situations or when necessary

Standard torques

- The torques are established by frame so as to provide shorter braking times

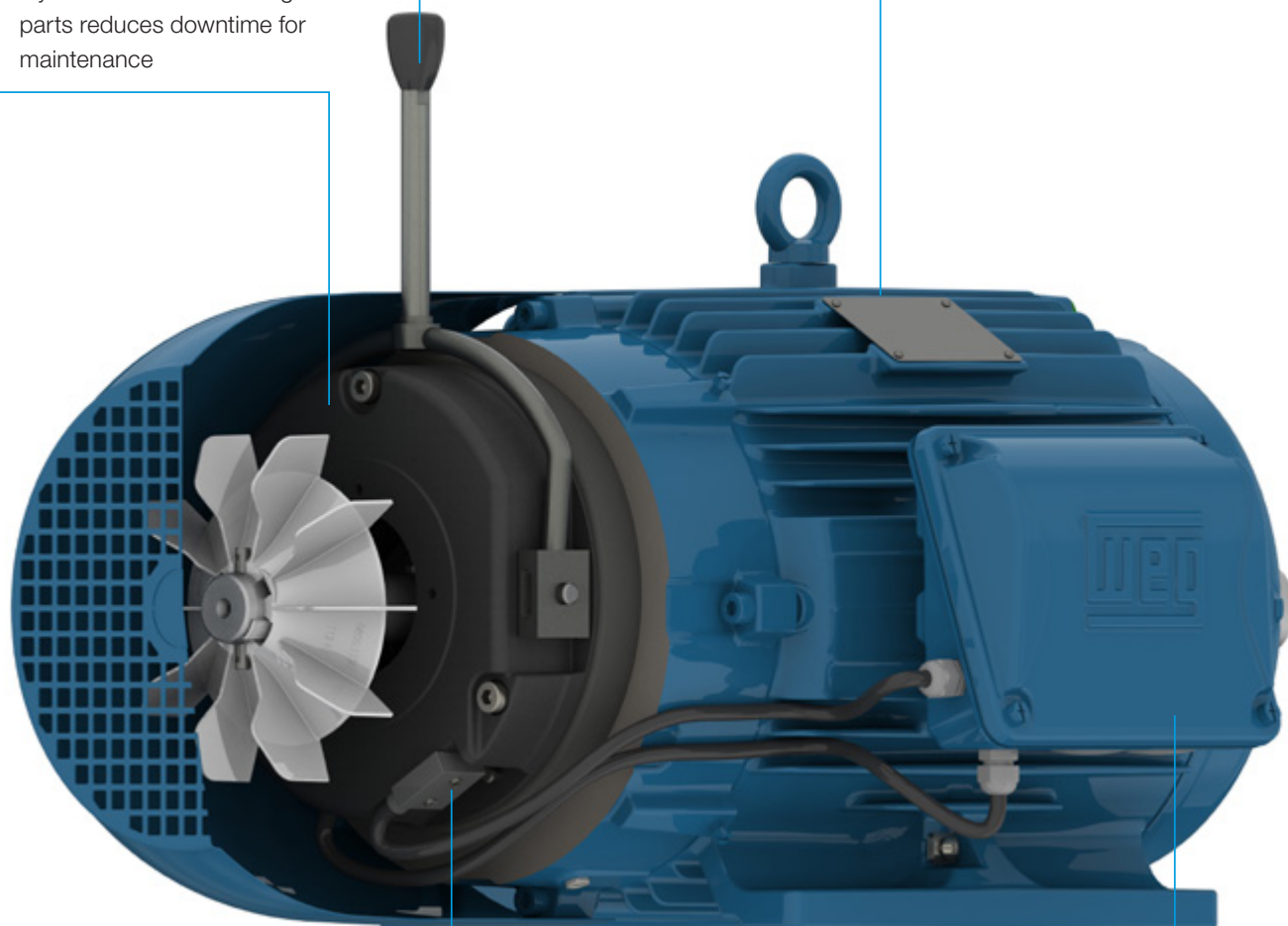

Microswitch (optional)

- Sensor to monitor the opening (I/O) or wear of the brake
- It informs the moment to replace the brake, eliminating the need of manual monitoring

Rectifier

- It can operate with voltage variations of up to 10%
- Robust and compact construction that allows installation in the motor main terminal box

General features

How does a brake work?

In order to ensure fast and accurate stops, the system of the W22 Brake Motor works as follows: when the motor is disconnected from the line, the current of the brake coil is also interrupted, which makes the coil stop actuating. Then, the springs push the armature towards the motor, compressing the brake disc between the armature and the ND-endshield, thus braking the motor.

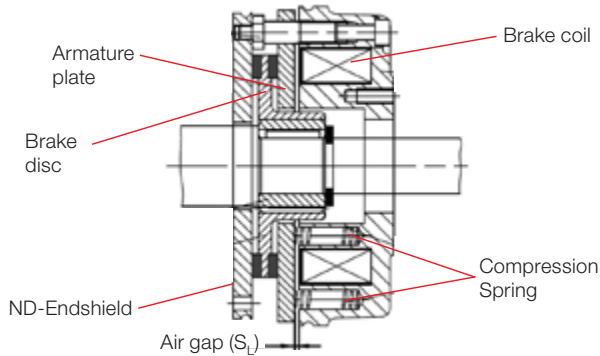

Figure 1 - Scheme of the brake components.

At a new start, the system simultaneously starts the motor and powers up the brake coil. The armature is attracted against the frame of the brake coil, overcoming the pressure of the springs and releasing the brake disc, which moves in the axial direction away from the friction surface. Thus, the braking action ceases and the motor is free to start.

Electromagnetic coil power supply

The electromagnetic coil is powered by direct current (DC) which can be supplied by a DC voltage source or bridge rectifier which converts AC to DC current. The bridge rectifier consists of diodes and varistors that filter undesirable voltage spikes and enable fast current shutdown. The direct current power supply provides higher speed and reliable brake operation.

The alternating current (AC) power supply for the bridge rectifier can be obtained from an independent source, or from the motor terminals, provided the motor is not supplied by frequency inverter. This power supply can be 220/230/240 V, 380/400/415 V, or 440/460/480 V, according to the features of the bridge rectifier/brake coil assembly. The electromagnetic coil can be operated continuously within $\pm 10\%$ of its rated voltage.

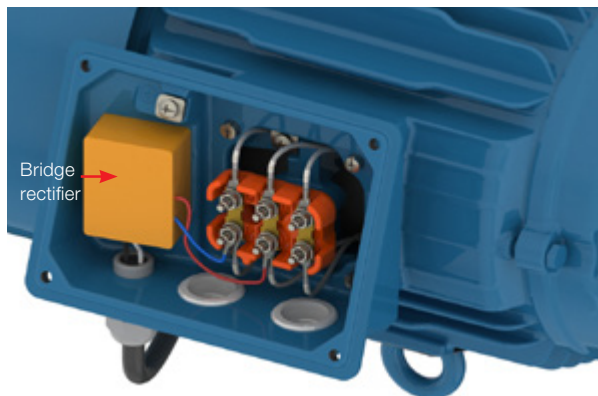

Figure 2 - Detail of the bridge rectifier inside the terminal box.

If the brake coil is supplied by direct current, it must be directly connected to the brake terminals.

Braking system

The W22 Brake Motor allows two braking system: Normal Braking or Fast Braking.

Normal Braking

The bridge rectifier of the brake coil can be supplied directly from the motor terminals, without interruption, as shown in Figure 3.

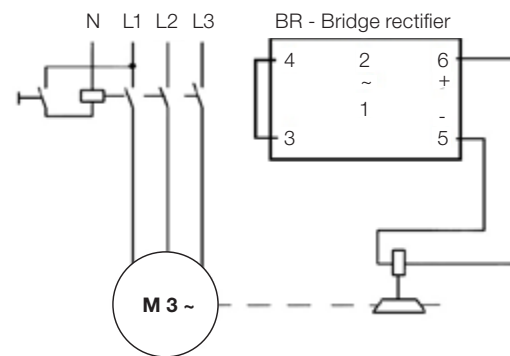

Figure 3 - Connection diagram of the bridge rectifier for normal braking.

Fast Braking

For fast braking, the bridge rectifier must be connected as shown in Figure 4.

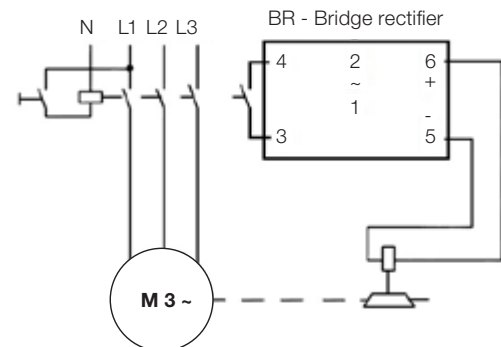

Figure 4 - Connection diagram of the bridge rectifier for fast braking.

Air gap adjustment

In order to ensure proper operation of the brake, it is important to check and adjust the air gap (space between brake armature and frame), according to the values of Table 1.

Frame	Brake size	Air gap ($^{+0.1}_{-0.05}$) [mm]
63	6	0,2
71 e 80	8	
90	10	
100	12	0,3
112	14	
132	16	
160	18	0,4
180	20	
200/225	25	0,5
250	31	

Table 1 - Values to adjust the air gap.

Power and resistance of the brake stator

Frame	Brake size	Brake voltage [V]	Electric power [W]	Resistance [ohm]
63	6	180	20	1620
		205		2101
		250		3125
71/80	8	180	25	1296
		205		1681
		250		2500
90	10	180	32	1013
		205	33	1273
		250		1894
100	12	180	40	810
		205		1051
		250		1563
112	14	180	53	611,3
		205		792,9
		250		1179
132	16	180	55	589,1
		205	56	750,5
		250		1116
160	18	180	85	387,2
		205		494,4
		250		735
180	20	180	100	324
		205		420,3
		250		625
200/225	25 (up to 600 Nm)	180	110	294,6
		205		382,1
		250		568
225/250	25 (> 600 Nm)	205	528	79,6
	31	360		245,5
				920

Table 2 - Power and resistance of the brake stator.

Optional accessories

In order to ensure even more safety and convenience for the application, the W22 Brake Motors can be supplied with some special features:

Manual release lever

It allows the motor shaft to be released in emergency cases or power outages. It can be supplied for motors up to frame 200L.

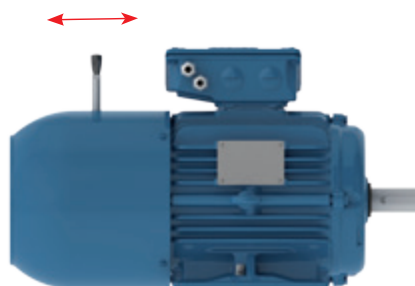

Figure 5 - Detail of the manual release lever.

Note: Under normal operating conditions, the lever cannot be activated.

Microswitch

From frame 100L up, the motors can be supplied with a monitoring sensor of the opening (I/O) or wear of the brake.

- Monitoring of the opening: ensures that the motor will not start if the brake is actuated (it prevents motor starts with the shaft locked);
- Monitoring of the wear: indicates the right moment to adjust or replace the brake lining.

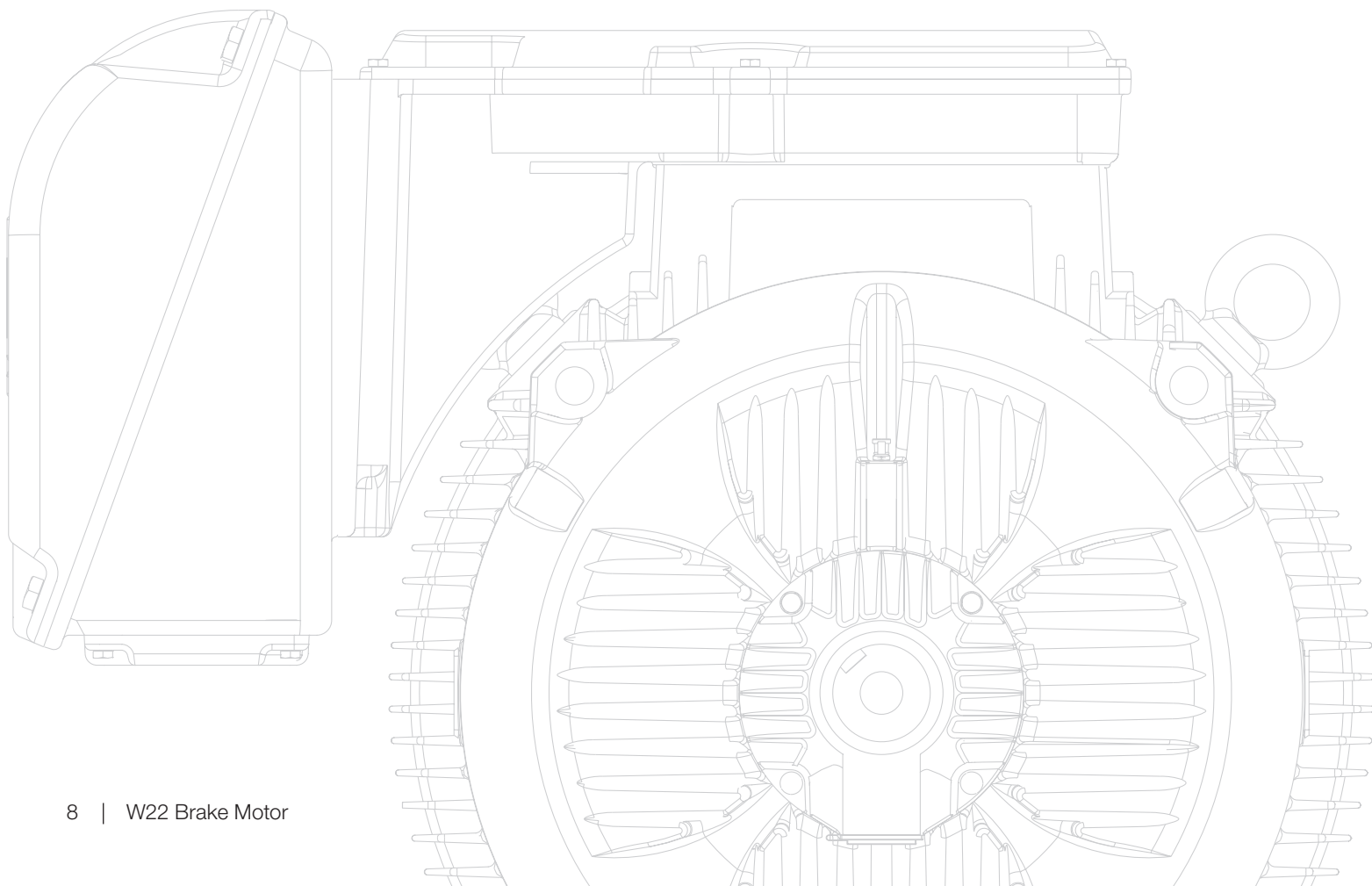

How to choose a W22 Brake Motor

The W22 Brake Motor is a motor for quite specific applications that demand high safety and accuracy. Therefore, it is extremely important to take into account some criteria when choosing such equipment.

Basic data to make the best choice:

Determine the motor and the brake: the first step is to define the environment in which the equipment will be used so as to select the motor with the best electromechanical characteristics for the application. The type of brake must also be checked, informing the power supply and the required braking torque.

Define the ambient temperature: taking into account the ambient temperature at which the motor will operate, we can determine the minimum ideal cooling system for the brake operation, according to Table 3.

Ambient temperature	Minimum cooling system of the motor
Up to 40 °C	No ventilation / W-Easy Maintenance
41 °C to 50 °C	Self-Ventilated / Air Over
51 °C to 60 °C	Blower cooled
61 °C to 70 °C	Blower cooled*

Table 3 - Definition of the cooling system according to the motor ambient temperature.
* For this condition, please contact WEG.

For other cooling system configurations, contact WEG.

Specify the degree of protection: the enclosures of electrical equipment, according to the characteristics and access conditions of the installation environment, must offer a certain degree of protection. Thus, equipment to be installed in a place subject to water jets, for example, must have an enclosure capable of withstanding such jets under certain pressures and angles of incidence without water ingress. Table 4 indicates the minimum cooling system necessary to ensure the degree of protection.

Degree of protection	Minimum cooling system of the motor
IP55	<ul style="list-style-type: none"> ■ No ventilation / Air Over (with fan cover) ■ Self-ventilated ■ With or without release lever
IP56 / IP65 / IP66	<ul style="list-style-type: none"> ■ Self-ventilated with brake protection cover ■ Without release lever
	<ul style="list-style-type: none"> ■ W-Easy Maintenance ■ With or without release lever

Table 4 - Degrees of protection and minimum cooling systems of the motor.

For other configurations, contact WEG.

Define the braking torque.

The W22 brake motor line offers up to two torques per frame:

- Rated torque: standard torque supplied;
- Optional torque: used in load lifting applications, or where, due to the high load torque and/or inertia of the system, it is necessary the use of greater braking torques.

Available braking torques (M_k): The braking torque must be equal to or greater than the motor rated torque. Table 5 contains the main characteristics of the brakes, using the speed of 100 rpm as reference.

Frame	Torque at 100 rpm [Nm]		Maximum working speed [rpm]	Maximum dissipated energy Q _e [J]	Brake response time t ₁₂ [s]
	Rated torque	Optional torque			
63	4	-	6.000	3.000	0,015
71	8	-	5.000	7.500	0,017
80		12			
90	16	23	4.000	12.000	0,020
100	32	46	3.600	24.000	0,030
112	60	-		30.000	
132	80	125		36.000	
160	150	235		60.000	0,043
180	260	345		80.000	0,100
200	400	530	3.000	120.000	0,120
225	530	800			0,135
250	800	-			
		-	1200	2.300	300.000

Table 5 - Characteristics of the brake according to the size and torque at 100 rpm.

Caution: The nominal torque of the electromagnetic brake is only reached after short period of operation after proper seating of the brake disc. The resulting friction coefficient of the brake disc may vary due to its manufacturing and assembly process, resulting in a variation of the specified brake torque, especially when a new brake disk is installed. This variation has been already considered when the brake is specified however, requires again the user's attention in the first operation of a new brake set + motor. A reduction of the brake torque can also occur after long periods without brake operation caused due to the presence of moisture and / or variation of the ambient temperature.

Safety factor (k): For regular applications, WEG recommends the use of the safety factor "k" of 1.5 to 2 times the torque value. For special applications, such as lifting, it is recommended a safety factor "k" of 2 to 3 times the rated torque.

Check the brake power supply: The W22 brake motor can be supplied with full, half wave or special bridge rectifiers, as shown in Table 6.

Rated voltage V _{RMS} [Vca]	Brake size	Brake coil voltage [Vcc]	Wave form
110	6 to 25	103	Full
220-240		205	
380-415		180	Half wave
440-480		205	
525-575		250	
220-240	25	205/103	Special = Full / Half wave
400-415	31	360/180	

Table 6 - Bridge rectifier types.

Calculations for special applications

Calculation of the required torque for load lifting.

For vertical applications, the braking torque must be obtained by means of the required torque calculation (M_{req}), which is given by the following expression:

$$M_{req} = k * \left(\frac{J_L * \Delta no}{9.55 * \left(\frac{t_3 - t_{12}}{2} \right)} + M_L \right)$$

Where:

M_{req} : required torque [Nm];

“k”: safety factor that must be added due to the uncertainties of the speed at the brake, maximum torque, maximum load inertia, among other variables.

J_L : total inertia on the rotor shaft = load inertia + system inertia + motor inertia [kgm²];

Δno : speed [rpm];

t_3 : required braking time [s];

t_{12} : brake response time [s].

Calculation of the required torque for application in translational motion of overhead cranes.

For horizontal applications, the braking torque must also be obtained by means of the required torque calculation (M_{req}), which is given by the following expression:

$$M_{req} = \left(\frac{k * J_L * \Delta no}{9,55 * \left(\frac{t_3 - t_{12}}{2} \right)} \right)$$

Correction of the torque due to the speed at the moment of the brake (M_R):

in cases of emergency stops (at working speed) or in motors without frequency inverter, the motor rated speed is considered the braking speed. Thus, the braking torque must be corrected as indicated in Table 7.

Brake size	Torque correction at speed (rpm) [%]							
	750	900	1000	1200	1500	1800	3000	3600
06	93,5	92	91	89,5	87	85	80	78,5
08	92,5	91	89,7	87,7	85	83	78	76,5
10	91,5	89,5	88,2	86	83	81	76	74,7
12	90,5	88,2	87	84,2	81	78,8	74	72,2
14	90	87,5	86	83,5	80	77,7	73	71,5
16	89,5	87	85,5	82,5	79	76,5	72	70,2
18	88	85,7	84	80,7	77	74,5	70	68
20	87	84,5	82,5	79	75	72,2	68	66,2
25	86	83	81	77,5	73	70,1	66	-
31	82	79	77	73	69	65	-	-

Table 7 - Torque correction.

For brakes with frequency inverter, it is necessary to know the speed at which the brake will be performed, and the braking torque must be corrected if necessary.

$$M_R = \frac{M_{req} * 100}{\text{correction} (\%)}$$

Finally, it must be checked if the corrected required torque is equal to or smaller than the torque of the selected brake. If it is bigger, it will be necessary to increase the torque of the brake.

$$M_K \geq M_R$$

Check the cooling of the brake:

after selecting the brake, it is necessary to check if the cooling will meet the start duty cycle of the application. The cooling can be obtained through the following equation:

$$Q = \frac{J_L * \Delta no^2}{182.5} * \frac{M_K}{M_K - M_L}$$

Where:

Q: dissipated heat [J];

M_K : brake torque [Nm];

M_L : load torque [Nm].

With the result found, the value of “Q” must be positioned on the axis of ordinates and the number of starts per hour on the axis of abscissa, and then we should observe if the point is below the curve of the selected brake. If it is below the curve, it indicates that the brake is thermally able to brake the load. Otherwise, the size of the brake must be increased so as to improve the cooling.

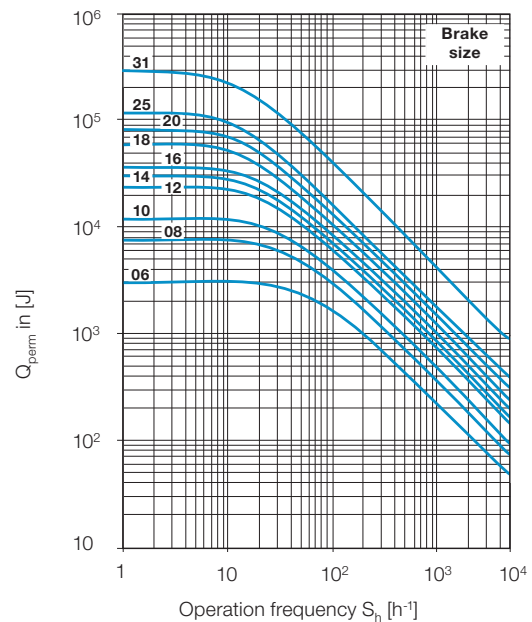

Figure 6 – Cooling curve (Q) according to starts per hour.

Brake power supply. When the brake coil is powered by a bridge rectifier, its input terminals must be supplied with alternate voltage. The relations between the motor voltage, the type of bridge rectifier and the brake coil power supply must be in accordance with Table 8.

Motor power supply (connection) [VAC]	Power supply of the brake bridge rectifier [VAC]	Brake type		Supply of the bridge rectifier through the motor electrical connections (IEC-NBR / NEMA)				
		Normal	Fast	Terminal 1 (**)	Terminal 2 (**)			
					3-wire motor	6-wire motor	9-wire motor	12-wire motor
220/230/240 (T)	220/230/240	Figure 3	Figure 4	U1 / T1	W1 / T3	W1 / T3	W1 / T3	W1 / T3
380/400/415 (Y)					NA	W2 / T6	NA	W4 / T12
380/400/415 (T)	W1 / T3				W1 / T3	W1 / T3	W1 / T3	
440/460 (Y)	NA				NA	NA	NA	
440/460 (T)	440/460				W1 / T3	W1 / T3	W1 / T3	W1 / T3
525/550/575 (Y)	NA				NA	NA	NA	
525/550/575 (T)	525/550/575				W1 / T3	W1 / T3	W1 / T3	W1 / T3

Table 8 - Power supply of the bridge rectifier through the motor terminals.

T = Delta connection Y = Star connection NA = Not available

* The bridge rectifier can be directly supplied by the motor cables or independently, at the customer's discretion.

** Terminal markings are only valid for single speed motors.

Note: besides the previous options, the electromagnetic brake with 24-Vdc coil is also available. In this case, only the brake is included (bridge rectifier not supplied) and the brake coil must be powered by an independent source.



Electric Data

W22 Brake Motor - High Efficiency - IE2

Output		Frame	Full load torque (Nm)	Locked rotor current I _L /I _n	Locked rotor torque T _L /T _n	Breakdown torque T _b /T _n	Inertia J (kgm ²)	Allowable locked rotor time (s)		Weight (kg)	Sound dB (A)	400 V							
								Hot	Cold			Rated speed (rpm)	% of full load			Full load current I _n (A)			
													Efficiency		Power factor				
kW	HP											50	75	100	50	75	100		
II pole - 3000 rpm - 50 Hz																			
0,12	0,16	63	0,410	4,8	3,0	2,9	0,0001	37	81	6,7	52,0	2790	53,0	60,0	60,7	0,53	0,66	0,75	0,380
0,18	0,25	63	0,620	5,3	2,3	2,4	0,0001	15	33	7,2	52,0	2790	57,0	62,0	64,0	0,57	0,70	0,79	0,510
0,25	0,33	63	0,860	5,0	2,2	2,2	0,0002	11	24	7,7	52,0	2770	58,0	63,0	65,0	0,57	0,70	0,80	0,690
0,37	0,5	71	1,25	5,8	2,5	2,6	0,0004	12	26	9,8	56,0	2830	68,0	70,0	71,0	0,60	0,75	0,84	0,895
0,55	0,75	71	1,89	5,8	2,4	2,4	0,0005	9	20	11,5	56,0	2780	70,0	72,0	74,1	0,68	0,82	0,88	1,22
0,75	1	80	2,56	6,5	2,8	2,8	0,0008	14	31	14,0	59,0	2800	76,0	78,5	79,5	0,67	0,80	0,86	1,58
1,1	1,5	80	3,75	6,5	2,8	2,8	0,0009	10	22	15,5	59,0	2800	78,0	80,0	80,0	0,67	0,79	0,85	2,33
2,2	3	90L	7,40	6,6	3,0	3,0	0,0022	9	20	23,5	64,0	2840	83,0	83,6	83,6	0,63	0,76	0,83	4,58
3	4	100L	9,95	8,0	2,4	2,8	0,0064	7	15	32,5	67,0	2880	84,0	85,0	85,0	0,70	0,81	0,86	5,92
4	5,5	112M	13,3	7,0	2,0	2,8	0,0088	10	22	44,0	64,0	2880	86,0	86,0	86,0	0,73	0,83	0,88	7,63
5,5	7,5	132S	17,9	6,8	2,2	3,0	0,0197	17	37	69,0	68,0	2930	86,5	88,0	88,0	0,68	0,79	0,85	10,6
7,5	10	132S	24,6	6,8	2,2	2,9	0,0251	13	29	72,0	68,0	2910	88,0	88,5	88,5	0,72	0,82	0,87	14,1
9,2	12,5	132M	30,2	7,6	2,5	3,2	0,0234	10	22	72,0	68,0	2915	88,5	89,0	89,0	0,70	0,81	0,86	17,3
11	15	160M	35,8	7,0	2,3	3,0	0,0446	13	29	123	67,0	2935	90,0	90,6	90,5	0,71	0,82	0,86	20,4
15	20	160M	48,9	7,0	2,3	3,0	0,0517	9	20	131	67,0	2930	91,0	91,3	91,3	0,71	0,81	0,86	27,6
18,5	25	160L	60,1	7,4	2,4	3,1	0,0625	8	18	143	67,0	2940	91,3	92,0	92,0	0,70	0,80	0,86	33,7
22	30	180M	71,4	7,3	2,2	3,0	0,0975	9	20	193	67,0	2945	92,0	92,4	92,2	0,76	0,84	0,88	39,1
30	40	200L	97,0	6,5	2,4	2,7	0,1703	17	37	267	72,0	2955	92,5	93,0	92,9	0,75	0,83	0,87	53,6
37	50	200L	120	6,8	2,4	2,6	0,1950	16	35	296	72,0	2950	93,0	93,4	93,3	0,76	0,84	0,87	65,8
45	60	200L	146	6,6	2,1	2,4	0,2204	15	33	313	72,0	2955	92,5	92,9	92,9	0,76	0,84	0,87	80,4

High-Output Design

0,37	0,5	63	1,29	5,0	2,2	2,2	0,0002	7	15	8,2	52,0	2740	64,0	67,0	69,5	0,56	0,71	0,81	0,949
0,75	1	71	2,59	5,8	2,8	2,8	0,0005	14	31	10,5	56,0	2770	77,0	77,5	77,6	0,67	0,80	0,87	1,60
0,75	1	90S	2,51	6,5	2,7	2,8	0,0012	25	55	18,0	64,0	2850	77,0	79,0	79,0	0,61	0,73	0,80	1,71
1,1	1,5	90S	3,71	6,1	2,5	2,6	0,0014	16	35	19,0	64,0	2835	80,0	80,5	80,5	0,65	0,77	0,83	2,38
1,5	2	80	5,17	6,5	3,1	3,0	0,0009	15	33	16,5	59,0	2770	80,0	81,0	81,5	0,65	0,78	0,85	3,13
1,5	2	90L	5,00	7,0	2,6	2,8	0,0021	7	15	20,0	64,0	2865	80,0	82,0	82,0	0,63	0,76	0,83	3,14
2,2	3	100L	7,29	7,5	2,6	3,0	0,0043	15	33	30,5	67,0	2885	82,5	83,6	83,6	0,66	0,78	0,85	4,47
4	5,5	100L	13,3	7,8	3,0	3,4	0,0064	10	22	36,0	67,0	2870	85,2	85,8	85,8	0,67	0,80	0,86	7,82
5,5	7,5	112M	18,3	7,3	2,7	3,0	0,0088	11	24	48,0	64,0	2880	86,5	87,0	87,0	0,72	0,82	0,87	10,5
5,5	7,5	132M	17,9	6,8	2,2	3,0	0,0197	17	37	69,0	68,0	2930	86,5	88,0	88,0	0,68	0,79	0,85	10,6
7,5	10	132M	24,6	6,8	2,2	2,9	0,0251	13	29	72,0	68,0	2910	88,0	88,5	88,5	0,72	0,82	0,87	14,1
11	15	132M	36,2	7,2	2,4	2,9	0,0270	11	24	83,0	68,0	2905	89,3	89,6	89,6	0,75	0,84	0,88	20,1
11	15	160L	35,8	7,0	2,3	3,0	0,0446	13	29	123	67,0	2935	90,0	90,6	90,5	0,71	0,82	0,86	20,4
15	20	160L	48,9	7,0	2,3	3,0	0,0517	9	20	131	67,0	2930	91,0	91,3	91,3	0,71	0,81	0,86	27,6
18,5	25	180M	60,1	7,0	2,1	2,9	0,0867	10	22	185	67,0	2940	91,4	92,0	91,8	0,75	0,84	0,88	33,1
22	30	160L	71,6	7,9	2,5	3,1	0,0813	10	22	159	67,0	2935	91,2	91,6	91,6	0,75	0,84	0,89	39,0
22	30	180L	71,4	7,3	2,2	3,0	0,0975	9	20	193	67,0	2945	92,0	92,4	92,2	0,76	0,84	0,88	39,1
30	40	180L	97,5	8,2	2,2	2,9	0,1301	8	18	223	76,0	2940	91,5	92,0	92,0	0,78	0,86	0,89	52,9

Notes:

- (1) Efficiency values are given according to IEC 60034-2-1. They are calculated according to indirect method, with stray load losses determined by measurement.
- (2) With effect from 1st January 2015, IE2 motors placed onto the European Market must be used with a variable speed drive unless their design falls outside of the scope of the European Regulation or their final installation will be outside of the EU / EEA.

Output		380 V								415 V							
		Rated speed (rpm)	% of full load						Full load current In (A)	Rated speed (rpm)	% of full load						Full load current In (A)
			Efficiency			Power factor					Efficiency			Power factor			
kW	HP	50	75	100	50	75	100	50	75	100	50	75	100	50	75	100	

II pole - 3000 rpm - 50 Hz

0,12	0,16	2765	54,7	60,6	60,7	0,57	0,71	0,79	0,380	2805	51,4	59,0	60,6	0,50	0,63	0,72	0,383
0,18	0,25	2760	58,0	63,0	64,0	0,61	0,75	0,83	0,510	2805	55,0	60,9	63,6	0,53	0,66	0,76	0,514
0,25	0,33	2740	60,3	64,1	65,0	0,63	0,76	0,84	0,690	2785	55,9	61,7	64,8	0,53	0,66	0,76	0,706
0,37	0,5	2805	69,0	70,1	70,3	0,66	0,79	0,87	0,900	2845	66,9	69,7	71,2	0,57	0,72	0,82	0,882
0,55	0,75	2750	70,8	71,9	74,1	0,73	0,85	0,91	1,24	2795	68,9	71,7	74,1	0,63	0,79	0,86	1,20
0,75	1	2815	80,5	81,3	79,6	0,70	0,81	0,87	1,65	2810	75,0	78,5	79,5	0,64	0,77	0,84	1,56
1,1	1,5	2775	78,9	79,2	79,6	0,73	0,83	0,87	2,43	2815	77,1	80,2	80,2	0,62	0,75	0,82	2,33
2,2	3	2820	83,7	83,5	83,2	0,69	0,80	0,85	4,75	2855	82,2	83,4	83,9	0,59	0,72	0,80	4,56
3	4	2865	84,9	85,0	85,0	0,76	0,85	0,88	6,09	2890	83,1	84,6	85,0	0,66	0,78	0,84	5,85
4	5,5	2865	86,6	86,0	85,8	0,78	0,87	0,90	7,90	2890	85,3	85,9	86,3	0,69	0,80	0,86	7,50
5,5	7,5	2915	87,1	87,6	87,6	0,74	0,83	0,88	10,8	2935	85,6	87,6	88,0	0,63	0,76	0,83	10,5
7,5	10	2900	88,4	88,4	88,1	0,77	0,85	0,89	14,5	2915	87,3	88,3	88,7	0,67	0,79	0,85	13,8
9,2	12,5	2905	89,1	89,0	89,0	0,75	0,85	0,89	17,6	2920	87,6	88,6	89,0	0,65	0,77	0,84	17,1
11	15	2930	90,3	90,5	90,1	0,75	0,85	0,88	21,1	2940	89,6	90,5	90,6	0,67	0,79	0,84	20,1
15	20	2930	91,4	91,3	90,9	0,76	0,84	0,88	28,5	2935	90,6	91,2	91,4	0,67	0,78	0,84	27,2
18,5	25	2930	91,6	91,9	91,6	0,74	0,83	0,88	34,9	2945	91,0	91,9	92,2	0,66	0,77	0,84	33,2
22	30	2940	92,2	92,2	91,8	0,79	0,86	0,89	40,9	2950	91,8	92,4	92,4	0,73	0,82	0,87	38,1
30	40	2950	92,7	92,9	92,6	0,79	0,85	0,88	55,9	2960	92,3	93,0	93,0	0,71	0,81	0,86	52,2
37	50	2945	93,2	93,3	93,0	0,80	0,86	0,88	68,7	2955	92,8	93,4	93,5	0,73	0,82	0,86	64,0
45	60	2950	92,6	92,9	92,9	0,80	0,87	0,89	82,7	2960	92,4	93,0	92,9	0,72	0,82	0,86	78,4

High-Output Design

0,37	0,5	2705	65,0	67,6	69,5	0,62	0,76	0,83	0,975	2760	61,1	66,2	69,5	0,52	0,66	0,77	0,962
0,75	1	2750	77,0	77,4	77,4	0,73	0,84	0,90	1,64	2890	76,0	77,6	77,6	0,62	0,76	0,85	1,58
0,75	1	2830	77,8	79,1	78,3	0,66	0,77	0,83	1,75	2860	76,0	78,7	79,2	0,56	0,70	0,78	1,69
1,1	1,5	2810	80,7	80,3	79,6	0,70	0,80	0,85	2,47	2850	79,2	80,4	81,0	0,60	0,74	0,81	2,33
1,5	2	2750	81,0	81,5	81,3	0,71	0,83	0,88	3,19	2790	80,0	81,0	81,7	0,59	0,74	0,82	3,11
1,5	2	2840	80,5	81,6	81,6	0,68	0,79	0,85	3,25	2880	79,3	81,9	82,5	0,58	0,73	0,81	3,08
2,2	3	2870	83,3	83,8	83,2	0,71	0,82	0,87	4,62	2895	81,5	83,2	83,6	0,62	0,75	0,82	4,46
4	5,5	2860	85,5	85,8	85,8	0,73	0,83	0,88	8,05	2880	85,0	86,0	86,0	0,63	0,76	0,83	7,80
5,5	7,5	2865	87,0	86,9	87,0	0,76	0,86	0,89	10,8	2885	85,9	86,8	87,2	0,67	0,79	0,85	10,3
5,5	7,5	2915	87,1	87,6	87,6	0,74	0,83	0,88	10,8	2935	85,6	87,6	88,0	0,63	0,76	0,83	10,5
7,5	10	2900	88,4	88,4	88,1	0,77	0,85	0,89	14,5	2915	87,3	88,3	88,7	0,67	0,79	0,85	13,8
11	15	2895	89,4	89,5	89,6	0,79	0,87	0,89	21,0	2910	88,7	89,4	89,8	0,71	0,81	0,86	19,8
11	15	2930	90,3	90,5	90,1	0,75	0,85	0,88	21,1	2940	89,6	90,5	90,6	0,67	0,79	0,84	20,1
15	20	2930	91,4	91,3	90,9	0,76	0,84	0,88	28,5	2935	90,6	91,2	91,4	0,67	0,78	0,84	27,2
18,5	25	2935	91,6	91,8	91,4	0,78	0,86	0,89	34,6	2945	91,2	92,0	92,0	0,72	0,82	0,87	32,2
22	30	2930	91,2	91,6	91,5	0,79	0,87	0,90	40,6	2940	91,0	91,6	91,8	0,72	0,82	0,87	38,3
22	30	2940	92,2	92,2	91,8	0,79	0,86	0,89	40,9	2950	91,8	92,4	92,4	0,73	0,82	0,87	38,1
30	40	2935	91,5	92,0	92,0	0,81	0,88	0,90	55,0	2945	91,8	92,3	92,3	0,75	0,84	0,88	51,4



Output		380 V									415 V								
		Rated speed (rpm)	% of full load						Full load current In (A)	Rated speed (rpm)	% of full load						Full load current In (A)		
			Efficiency			Power factor					Efficiency			Power factor					
kW	HP	50	75	100	50	75	100	50	75	100	50	75	100	50	75	100			

IV pole - 1500 rpm - 50 Hz

0,12	0,16	1360	56,8	58,7	59,1	0,58	0,71	0,80	0,386	1390	53,2	57,1	59,1	0,51	0,64	0,74	0,382
0,18	0,25	1380	60,4	61,3	64,7	0,52	0,65	0,74	0,571	1410	57,7	60,6	64,7	0,48	0,58	0,68	0,569
0,25	0,33	1400	60,0	65,0	68,5	0,53	0,66	0,74	0,749	1420	57,8	64,5	68,5	0,46	0,59	0,69	0,736
0,37	0,5	1380	66,0	68,5	72,7	0,55	0,66	0,76	1,02	1405	63,0	68,0	72,7	0,46	0,58	0,69	1,03
0,55	0,75	1445	73,0	73,1	77,1	0,60	0,72	0,78	1,39	1455	70,7	73,8	77,1	0,51	0,60	0,70	1,42
0,75	1	1400	79,0	79,5	79,6	0,68	0,80	0,84	1,70	1415	77,9	79,2	79,9	0,60	0,73	0,79	1,65
1,1	1,5	1432	81,9	81,8	81,5	0,67	0,78	0,83	2,47	1444	80,1	81,5	82,1	0,58	0,72	0,79	2,36
1,5	2	1430	82,8	83,2	82,8	0,63	0,77	0,83	3,32	1445	80,1	82,3	83,1	0,53	0,68	0,78	3,22
2,2	3	1425	83,5	84,3	84,3	0,65	0,77	0,83	4,80	1440	82,3	84,5	84,9	0,56	0,71	0,79	4,56
3	4	1410	85,4	85,5	85,5	0,67	0,78	0,84	6,35	1425	84,3	85,5	86,0	0,58	0,72	0,80	6,07
4	5,5	1435	86,5	86,6	86,6	0,67	0,78	0,82	8,56	1445	85,3	86,6	87,0	0,58	0,71	0,78	8,20
5,5	7,5	1455	88,1	87,7	87,7	0,73	0,83	0,88	10,8	1460	86,5	87,3	87,7	0,65	0,77	0,84	10,4
7,5	10	1460	89,0	88,7	88,7	0,75	0,83	0,87	14,8	1465	88,3	89,0	89,4	0,63	0,75	0,81	14,4
9,2	12,5	1450	89,6	89,4	89,3	0,74	0,82	0,87	17,8	1455	88,7	89,5	89,8	0,65	0,77	0,84	16,8
11	15	1465	89,5	90,2	89,8	0,69	0,79	0,85	21,9	1470	88,5	90,0	90,3	0,61	0,73	0,81	20,9
15	20	1460	91,0	90,9	90,6	0,70	0,79	0,85	29,6	1470	90,2	90,9	91,2	0,63	0,73	0,81	28,2
18,5	25	1460	91,8	91,7	91,2	0,72	0,81	0,85	36,3	1470	91,1	91,7	91,7	0,60	0,75	0,81	34,7
22	30	1460	92,5	92,4	91,9	0,74	0,83	0,87	41,8	1465	91,8	92,4	92,4	0,66	0,77	0,83	39,9
30	40	1465	92,9	92,9	92,4	0,68	0,78	0,83	59,4	1470	92,3	92,9	92,9	0,61	0,73	0,79	56,9
37	50	1470	93,2	93,1	92,8	0,78	0,86	0,87	69,6	1475	92,7	93,1	93,3	0,70	0,81	0,85	64,9
45	60	1470	93,5	93,6	93,2	0,76	0,84	0,86	85,3	1475	92,9	93,6	93,7	0,68	0,79	0,82	81,5
55	75	1470	93,8	93,8	93,7	0,79	0,86	0,88	101	1475	93,3	93,9	94,1	0,72	0,82	0,86	94,6
75	100	1470	94,3	94,3	94,1	0,78	0,86	0,88	138	1475	93,7	94,2	94,5	0,71	0,82	0,85	130

High-Output Design

0,25	0,33	1410	71,0	74,0	73,2	0,65	0,77	0,84	0,618	1425	69,1	73,3	73,4	0,58	0,71	0,79	0,600
0,37	0,5	1410	74,1	75,6	74,8	0,65	0,77	0,84	0,895	1425	71,7	75,1	75,8	0,57	0,70	0,79	0,860
0,75	1	1415	79,1	79,9	79,6	0,64	0,76	0,83	1,72	1430	76,9	79,6	80,4	0,55	0,69	0,78	1,66
1,1	1,5	1440	80,9	81,5	81,5	0,59	0,71	0,80	2,56	1455	79,2	81,5	82,1	0,51	0,65	0,76	2,45
1,5	2	1415	82,5	82,8	82,8	0,66	0,77	0,83	3,34	1430	81,9	83,2	83,7	0,58	0,71	0,79	3,16
2,2	3	1455	85,0	84,8	84,3	0,67	0,78	0,83	4,78	1465	83,9	84,9	85,4	0,59	0,72	0,79	4,54
4	5,5	1470	86,0	86,5	86,6	0,63	0,76	0,83	8,46	1475	86,4	87,1	87,4	0,54	0,68	0,78	8,16
4	5,5	1470	86,0	86,5	86,6	0,63	0,76	0,83	8,46	1475	86,4	87,1	87,4	0,54	0,68	0,78	8,16
5,5	7,5	1455	88,1	87,7	87,7	0,73	0,83	0,88	10,8	1460	86,5	87,3	87,7	0,65	0,77	0,84	10,4
7,5	10	1460	89,0	88,7	88,7	0,75	0,83	0,87	14,8	1465	88,3	89,0	89,4	0,63	0,75	0,81	14,4
7,5	10	1460	88,5	89,1	88,7	0,69	0,80	0,85	15,1	1470	87,5	89,0	89,1	0,61	0,74	0,81	14,5
9,2	12,5	1460	89,0	89,5	89,3	0,70	0,80	0,85	18,5	1470	88,0	89,4	89,3	0,62	0,74	0,81	17,7
11	15	1450	89,0	89,6	89,8	0,70	0,81	0,86	21,6	1460	89,0	89,5	89,8	0,60	0,74	0,81	21,0
11	15	1465	89,5	90,2	89,8	0,69	0,79	0,85	21,9	1470	88,5	90,0	90,3	0,61	0,73	0,81	20,9
15	20	1460	91,3	91,5	91,0	0,71	0,80	0,85	29,5	1470	90,4	91,4	91,4	0,63	0,74	0,81	28,2
15	20	1460	91,3	91,5	91,0	0,71	0,80	0,85	29,5	1470	90,4	91,4	91,4	0,63	0,74	0,81	28,2
18,5	25	1460	90,5	91,0	91,2	0,71	0,81	0,85	36,3	1470	90,0	91,0	91,2	0,62	0,75	0,81	34,8
18,5	25	1460	91,8	91,7	91,2	0,72	0,81	0,85	36,3	1470	91,1	91,7	91,7	0,60	0,75	0,81	34,7
22	30	1460	92,5	92,4	91,9	0,74	0,83	0,87	41,8	1465	91,8	92,4	92,4	0,66	0,77	0,83	39,9
30	40	1460	91,9	92,3	92,3	0,72	0,81	0,84	58,8	1465	91,5	92,0	92,3	0,64	0,76	0,82	55,1
37	50	1470	93,1	92,9	92,7	0,74	0,83	0,85	71,3	1475	92,5	93,0	93,2	0,67	0,78	0,81	68,2
45	60	1470	92,8	93,0	93,1	0,70	0,80	0,84	87,4	1475	92,4	92,8	93,1	0,61	0,73	0,79	85,1
55	75	1475	93,0	93,5	93,5	0,78	0,85	0,87	103	1480	92,8	93,2	93,6	0,71	0,81	0,85	96,2

W22 Brake Motor - Premium Efficiency - IE3¹

Output		Frame	Full load torque (Nm)	Locked rotor current I _L /I _n	Locked rotor torque T _L /T _n	Breakdown torque T _b /T _n	Inertia J (kgm ²)	Allowable locked rotor time (s)		Weight (kg)	Sound dB (A)	400 V							
								Hot	Cold			Rated speed (rpm)	% of full load			Full load current I _n (A)			
													Efficiency		Power factor				
kW	HP	50	75	100	50	75	100												
II pole - 3000 rpm - 50 Hz																			
0,12	0,16	63	0,410	5,4	3,1	3,3	0,0001	30	66	7,2	52,0	2820	58,0	60,8	60,8	0,54	0,67	0,76	0,375
0,18	0,25	63	0,610	5,2	3,0	3,2	0,0002	22	48	7,7	52,0	2815	61,0	65,9	65,9	0,53	0,65	0,74	0,533
0,25	0,33	63	0,850	5,5	3,2	3,2	0,0002	17	37	8,2	52,0	2805	63,0	68,0	69,7	0,54	0,68	0,77	0,672
0,37	0,5	71	1,25	6,0	2,5	2,5	0,0004	12	26	9,0	56,0	2820	73,0	73,8	73,8	0,66	0,79	0,85	0,851
0,55	0,75	71	1,90	5,9	3,0	3,0	0,0005	18	40	10,0	56,0	2770	75,0	76,0	77,8	0,68	0,81	0,86	1,19
0,75	1	80	2,54	7,5	3,5	3,5	0,0008	25	55	15,0	59,0	2825	80,0	82,0	81,0	0,63	0,76	0,82	1,63
1,1	1,5	80	3,71	7,4	3,6	3,6	0,0009	23	51	16,5	59,0	2830	81,0	83,5	83,0	0,63	0,76	0,82	2,33
1,5	2	90S	4,99	7,6	3,3	3,3	0,0020	15	33	20,0	62,0	2875	83,0	85,0	84,5	0,64	0,76	0,83	3,09
2,2	3	90L	7,34	7,5	3,1	3,4	0,0026	12	26	26,0	62,0	2865	85,5	86,0	86,3	0,65	0,77	0,83	4,43
3	4	100L	9,85	8,5	3,4	3,4	0,0064	15	33	39,0	67,0	2910	85,5	87,3	87,3	0,69	0,81	0,86	5,77
4	5,5	112M	13,2	7,7	2,9	3,5	0,0081	22	48	47,0	64,0	2900	88,0	88,4	88,4	0,69	0,80	0,86	7,59
5,5	7,5	132S	17,9	7,9	2,4	3,5	0,0180	16	35	71,0	67,0	2930	86,9	88,7	89,4	0,66	0,78	0,84	10,6
7,5	10	132S	24,5	8,8	2,7	3,6	0,0234	10	22	74,0	67,0	2930	88,5	89,8	90,3	0,68	0,80	0,85	14,1
9,2	12,5	132M	30,0	8,5	2,8	3,1	0,0303	16	35	87,0	67,0	2935	90,4	91,1	90,7	0,75	0,84	0,88	16,6
11	15	160M	35,7	8,0	2,6	3,4	0,0482	12	26	131	67,0	2945	90,3	91,4	91,4	0,71	0,82	0,87	20,0
15	20	160M	48,7	8,3	2,8	3,5	0,0551	8	18	131	67,0	2945	90,9	91,8	92,1	0,67	0,79	0,85	27,7
18,5	25	160L	60,0	8,6	3,1	3,7	0,0663	6	13	189	67,0	2945	91,5	92,3	92,6	0,69	0,80	0,85	33,9
22	30	180M	71,3	8,3	2,7	3,6	0,0968	6	13	194	67,0	2950	92,3	93,0	92,9	0,69	0,80	0,86	39,7
30	40	200L	96,8	7,7	3,0	3,0	0,1703	16	35	266	72,0	2960	92,2	93,2	93,5	0,69	0,80	0,85	54,5
37	50	200L	119	7,7	3,1	3,0	0,1881	13	29	291	72,0	2960	92,6	93,4	93,8	0,69	0,79	0,84	67,8
High-Output Design																			
0,75	1	90S	2,47	8,2	3,3	3,4	0,0015	24	53	19,5	62,0	2900	79,0	82,5	81,5	0,63	0,75	0,82	1,62
1,1	1,5	90S	3,65	7,8	3,3	3,3	0,0018	19	42	20,0	62,0	2880	82,0	84,2	83,5	0,63	0,75	0,82	2,32
2,2	3	100L	7,22	8,5	3,2	3,3	0,0059	22	48	35,0	67,0	2910	85,0	86,6	86,6	0,71	0,82	0,87	4,21
4	5,5	132S	13,0	7,9	2,5	3,1	0,0180	24	53	70,0	67,0	2945	86,9	88,7	88,6	0,73	0,82	0,87	7,49
5,5	7,5	132M	17,9	7,9	2,4	3,5	0,0180	16	35	71,0	67,0	2930	86,9	88,7	89,4	0,66	0,78	0,84	10,6
7,5	10	132M	24,5	8,8	2,7	3,6	0,0234	10	22	74,0	67,0	2930	88,5	89,8	90,3	0,68	0,80	0,85	14,1
11	15	132M	35,9	8,2	2,7	3,0	0,0303	11	24	89,0	67,0	2925	90,6	91,1	91,2	0,75	0,85	0,89	19,6
11	15	160L	35,7	8,0	2,6	3,4	0,0482	12	26	124	67,0	2945	90,3	91,4	91,4	0,71	0,82	0,87	20,0
15	20	160L	48,7	8,3	2,8	3,5	0,0551	8	18	131	67,0	2945	90,9	91,8	92,1	0,67	0,79	0,85	27,7
18,5	25	180M	60,0	7,6	2,3	3,1	0,0973	11	24	194	67,0	2945	91,5	92,0	92,6	0,77	0,85	0,88	32,8
22	30	180L	71,3	8,3	2,7	3,6	0,0968	6	13	194	67,0	2950	92,3	93,0	92,9	0,69	0,80	0,86	39,7

Note:

(1) Efficiency values are given according to IEC 60034-2-1. They are calculated according to indirect method, with stray load losses determined by measurement.

Output		380 V								415 V							
		Rated speed (rpm)	% of full load						Full load current In (A)	Rated speed (rpm)	% of full load						Full load current In (A)
			Efficiency			Power factor					Efficiency			Power factor			
kW	HP	50	75	100	50	75	100	50	75	100	50	75	100	50	75	100	

II pole - 3000 rpm - 50 Hz

0,12	0,16	2795	59,0	60,8	60,8	0,58	0,71	0,79	0,380	2835	57,0	60,8	60,8	0,51	0,64	0,73	0,376
0,18	0,25	2790	62,6	65,9	65,9	0,57	0,70	0,79	0,525	2825	59,6	65,2	65,9	0,49	0,62	0,71	0,535
0,25	0,33	2780	64,6	68,7	69,7	0,59	0,73	0,81	0,673	2820	61,5	67,2	69,7	0,51	0,64	0,74	0,674
0,37	0,5	2795	73,6	74,3	73,8	0,71	0,82	0,87	0,876	2825	72,4	73,8	73,8	0,63	0,76	0,83	0,840
0,55	0,75	2740	75,6	75,7	77,8	0,73	0,84	0,88	1,22	2790	74,4	76,0	77,8	0,65	0,78	0,84	1,17
0,75	1	2805	80,0	80,5	80,7	0,68	0,80	0,85	1,66	2835	79,1	81,0	81,1	0,59	0,72	0,79	1,63
1,1	1,5	2810	82,0	83,7	83,1	0,69	0,80	0,85	2,37	2840	80,0	83,0	83,4	0,58	0,72	0,79	2,32
1,5	2	2860	83,7	85,0	84,4	0,69	0,80	0,85	3,18	2885	82,2	84,8	85,2	0,59	0,72	0,80	3,06
2,2	3	2840	85,0	85,5	85,9	0,70	0,81	0,86	4,52	2875	85,3	86,4	86,5	0,61	0,74	0,81	4,37
3	4	2900	86,0	87,4	87,1	0,75	0,84	0,88	5,95	2915	85,0	87,2	87,4	0,66	0,78	0,84	5,68
4	5,5	2890	88,0	88,2	88,2	0,73	0,83	0,88	7,83	2905	87,5	88,0	88,4	0,65	0,77	0,84	7,49
5,5	7,5	2925	87,6	88,9	89,2	0,71	0,82	0,87	10,8	2935	86,1	88,3	89,2	0,61	0,74	0,81	10,6
7,5	10	2926	89,2	90,1	90,1	0,73	0,83	0,88	14,4	2940	87,9	89,7	90,3	0,63	0,76	0,83	13,9
9,2	12,5	2925	90,7	91,0	90,8	0,79	0,87	0,90	17,1	2940	90,1	91,0	91,3	0,71	0,82	0,87	16,1
11	15	2940	90,7	91,2	91,2	0,75	0,84	0,88	20,8	2950	89,9	91,3	91,4	0,68	0,79	0,85	19,7
15	20	2940	91,0	91,6	91,9	0,72	0,82	0,87	28,5	2950	90,3	91,6	91,9	0,63	0,76	0,82	27,7
18,5	25	2945	92,0	92,3	92,4	0,74	0,83	0,88	34,6	2950	91,0	92,2	92,4	0,64	0,77	0,83	33,6
22	30	2945	92,4	92,7	92,7	0,74	0,83	0,87	41,4	2955	92,0	92,8	92,7	0,66	0,78	0,84	39,3
30	40	2960	92,6	93,2	93,3	0,75	0,83	0,87	56,2	2965	91,8	93,0	93,3	0,64	0,76	0,82	54,6
37	50	2960	93,0	93,6	93,7	0,75	0,84	0,87	69,0	2965	92,0	93,2	93,7	0,63	0,76	0,82	67,0

High-Output Design

0,75	1	2885	79,5	82,5	81,0	0,68	0,78	0,84	1,67	2910	78,4	82,3	81,5	0,60	0,72	0,79	1,62
1,1	1,5	2865	82,6	84,2	84,0	0,68	0,79	0,84	2,37	2890	81,4	84,0	84,7	0,59	0,72	0,80	2,26
2,2	3	2900	85,4	86,5	86,5	0,75	0,84	0,89	4,36	2915	84,7	86,5	86,8	0,68	0,80	0,86	4,10
4	5,5	2935	87,1	88,6	88,7	0,76	0,85	0,89	7,70	2950	86,6	88,6	89,2	0,69	0,80	0,86	7,25
5,5	7,5	2925	87,6	88,9	89,2	0,71	0,82	0,87	10,8	2935	86,1	88,3	89,2	0,61	0,74	0,81	10,6
7,5	10	2926	89,2	90,1	90,1	0,73	0,83	0,88	14,4	2940	87,9	89,7	90,3	0,63	0,76	0,83	13,9
11	15	2915	90,9	91,0	91,2	0,80	0,87	0,90	20,4	2930	90,2	91,1	91,4	0,72	0,82	0,87	19,2
11	15	2940	90,7	91,2	91,2	0,75	0,84	0,88	20,8	2950	89,9	91,3	91,4	0,68	0,79	0,85	19,7
15	20	2940	91,0	91,6	91,9	0,72	0,82	0,87	28,5	2950	90,3	91,6	91,9	0,63	0,76	0,82	27,7
18,5	25	2940	92,7	92,6	92,4	0,80	0,87	0,90	33,8	2950	92,5	92,9	92,5	0,75	0,84	0,88	31,6
22	30	2945	92,4	92,7	92,7	0,74	0,83	0,87	41,4	2955	92,0	92,8	92,7	0,66	0,78	0,84	39,3

W22 Brake Motor - Premium Efficiency - IE3¹

Output		Frame	Full load torque (Nm)	Locked rotor current I _L /I _n	Locked rotor torque T _L /T _n	Breakdown torque T _b /T _n	Inertia J (kgm ²)	Allowable locked rotor time (s)		Weight (kg)	Sound dB (A)	400 V							
								Hot	Cold			Rated speed (rpm)	% of full load			Full load current I _n (A)			
													Efficiency		Power factor				
kW	HP											50	75	100	50	75	100		
IV pole - 1500 rpm - 50 Hz																			
0,12	0,16	63	0,840	4,4	2,1	2,3	0,0004	30	66	6,2	44,0	1370	57,0	63,0	64,8	0,52	0,62	0,73	0,366
0,18	0,25	63	1,26	4,7	2,1	2,4	0,0006	30	66	8,2	44,0	1370	65,0	67,0	69,9	0,53	0,63	0,72	0,516
0,25	0,33	71	1,72	4,8	2,3	2,3	0,0009	30	66	9,5	43,0	1390	69,0	72,0	73,5	0,52	0,65	0,72	0,682
0,37	0,5	71	2,55	4,8	2,8	2,9	0,0008	30	66	11,0	43,0	1385	73,0	75,0	77,3	0,50	0,62	0,70	0,987
0,55	0,75	80	3,70	6,6	2,8	3,0	0,0027	20	44	14,0	44,0	1420	77,0	79,0	80,8	0,61	0,74	0,80	1,23
0,75	1	80	5,05	6,7	3,0	3,3	0,0032	18	40	16,0	44,0	1420	80,0	82,0	82,5	0,59	0,72	0,81	1,62
1,1	1,5	90S	7,25	7,6	2,5	2,9	0,0055	15	33	22,0	49,0	1450	83,0	84,5	84,5	0,59	0,72	0,80	2,35
1,5	2	90L	9,88	7,4	2,6	3,4	0,0066	13	29	25,5	49,0	1450	84,0	86,0	85,5	0,58	0,72	0,80	3,17
2,2	3	100L	14,7	7,4	3,2	3,5	0,0090	18	40	35,5	53,0	1435	86,5	87,0	87,0	0,60	0,73	0,80	4,56
3	4	112M	19,7	7,1	2,3	3,0	0,0169	25	55	49,0	56,0	1455	87,0	88,0	88,0	0,62	0,74	0,81	6,07
4	5,5	112M	26,4	7,0	2,3	3,1	0,0180	15	33	50,0	56,0	1450	88,7	89,1	88,8	0,60	0,72	0,79	8,23
5,5	7,5	132S	36,0	8,3	2,1	3,3	0,0491	12	26	75,0	56,0	1460	89,0	89,6	89,7	0,69	0,80	0,85	10,4
7,5	10	132M	49,1	8,3	2,4	3,5	0,0563	7	15	83,0	56,0	1460	90,5	90,8	90,6	0,63	0,76	0,84	14,2
9,2	12,5	132M/L	60,0	8,6	2,8	3,5	0,0698	10	22	91,0	56,0	1465	90,3	91,0	91,0	0,64	0,76	0,82	17,4
11	15	160M	71,5	7,5	2,8	3,2	0,1191	11	24	132	61,0	1470	91,1	91,8	91,6	0,65	0,77	0,83	20,9
15	20	160L	97,8	7,2	2,8	3,1	0,1534	8	18	154	61,0	1465	92,2	92,5	92,3	0,67	0,78	0,84	27,9
18,5	25	180M	120	7,4	3,0	3,2	0,1740	13	29	197	61,0	1470	92,2	92,8	92,8	0,64	0,76	0,82	35,1
22	30	180L	143	7,3	3,4	3,4	0,2097	11	24	214	61,0	1470	92,3	93,0	93,2	0,66	0,77	0,83	41,0
30	40	200L	194	7,5	2,8	3,1	0,3202	12	26	269	63,0	1480	92,9	93,6	93,7	0,63	0,75	0,81	57,1
37	50	200L	239	7,0	2,6	3,0	0,3994	14	31	325	63,0	1480	93,1	93,6	94,1	0,64	0,76	0,82	69,2
High-Output Design																			
0,75	1	90S	4,93	7,8	2,4	3,3	0,0049	21	46	21,0	49,0	1455	82,5	84,0	84,5	0,59	0,71	0,78	1,64
1,1	1,5	90L	7,25	7,6	2,5	2,9	0,0055	15	33	22,0	49,0	1450	83,0	84,5	84,5	0,59	0,72	0,80	2,35
1,5	2	100L	9,95	7,7	3,1	3,4	0,0082	25	55	34,0	53,0	1440	85,5	86,0	86,0	0,61	0,73	0,80	3,15
2,2	3	112M	14,5	6,8	2,0	3,0	0,0143	31	68	47,0	56,0	1450	87,5	88,2	88,2	0,62	0,74	0,81	4,44
5,5	7,5	132M	36,0	8,3	2,1	3,3	0,0491	12	26	75,0	56,0	1460	89,0	89,6	89,7	0,69	0,80	0,85	10,4
9,2	12,5	160M	59,6	7,2	2,5	3,0	0,1118	16	35	128	61,0	1475	90,0	91,4	91,3	0,66	0,77	0,83	17,5
11	15	160L	71,5	7,5	2,8	3,2	0,1191	11	24	132	61,0	1470	91,1	91,8	91,6	0,65	0,77	0,83	20,9
15	20	180M	97,5	7,0	2,5	3,0	0,1570	23	51	184	61,0	1470	91,9	92,5	92,3	0,66	0,77	0,83	28,3
18,5	25	180L	120	7,4	3,0	3,2	0,1740	13	29	197	61,0	1470	92,2	92,8	92,8	0,64	0,76	0,82	35,1

Note:

(1) Efficiency values are given according to IEC 60034-2-1. They are calculated according to indirect method, with stray load losses determined by measurement.

Output		380 V								415 V							
		Rated speed (rpm)	% of full load						Full load current In (A)	Rated speed (rpm)	% of full load						Full load current In (A)
			Efficiency			Power factor					Efficiency			Power factor			
kW	HP	50	75	100	50	75	100	50	75	100	50	75	100	50	75	100	

IV pole - 1500 rpm - 50 Hz

0,12	0,16	1355	58,6	64,0	64,8	0,56	0,69	0,76	0,370	1380	55,6	63,0	64,8	0,50	0,62	0,72	0,358
0,18	0,25	1355	65,0	67,0	69,9	0,57	0,67	0,75	0,522	1380	65,0	67,0	69,9	0,50	0,61	0,70	0,512
0,25	0,33	1375	67,0	69,1	73,5	0,56	0,69	0,75	0,689	1400	65,1	68,6	73,4	0,50	0,62	0,69	0,687
0,37	0,5	1370	73,0	75,0	77,3	0,53	0,64	0,72	1,01	1395	73,0	75,0	77,3	0,47	0,59	0,68	0,979
0,55	0,75	1410	78,0	79,1	80,8	0,65	0,77	0,83	1,25	1430	76,0	78,9	80,8	0,57	0,71	0,77	1,23
0,75	1	1410	80,8	82,0	82,5	0,64	0,75	0,83	1,66	1425	79,1	81,8	82,8	0,56	0,69	0,79	1,60
1,1	1,5	1445	84,0	84,7	84,3	0,64	0,76	0,83	2,39	1455	82,0	84,1	84,8	0,55	0,69	0,77	2,34
1,5	2	1445	85,0	86,2	85,6	0,63	0,76	0,83	3,21	1455	83,1	85,7	86,1	0,54	0,68	0,77	3,15
2,2	3	1430	87,2	87,1	86,7	0,65	0,77	0,83	4,64	1440	85,7	86,8	87,2	0,57	0,70	0,78	4,50
3	4	1450	87,5	87,7	87,7	0,66	0,77	0,83	6,26	1460	86,5	88,0	88,1	0,59	0,71	0,79	6,00
4	5,5	1445	89,3	89,0	88,6	0,65	0,76	0,81	8,47	1455	88,2	88,9	89,3	0,57	0,70	0,77	8,09
5,5	7,5	1460	89,0	89,6	89,6	0,73	0,83	0,87	10,7	1465	89,4	89,6	89,8	0,65	0,78	0,84	10,1
7,5	10	1460	90,0	90,2	90,4	0,66	0,79	0,86	14,7	1465	89,2	90,3	90,4	0,60	0,73	0,83	13,9
9,2	12,5	1460	91,0	91,1	91,0	0,69	0,80	0,85	17,7	1470	89,5	90,6	91,0	0,60	0,73	0,80	17,2
11	15	1470	91,7	91,4	91,4	0,69	0,80	0,85	21,5	1475	90,6	91,4	91,5	0,61	0,74	0,81	20,6
15	20	1465	92,4	92,4	92,1	0,70	0,80	0,85	29,1	1470	91,6	92,3	92,1	0,62	0,75	0,81	28,0
18,5	25	1470	92,7	92,6	92,6	0,69	0,79	0,84	36,1	1475	91,8	92,6	92,6	0,61	0,73	0,80	34,7
22	30	1470	92,5	92,8	93,0	0,70	0,81	0,85	42,3	1475	91,9	92,8	93,0	0,62	0,74	0,81	40,6
30	40	1475	93,4	93,6	93,6	0,68	0,79	0,84	58,0	1480	92,3	93,3	93,6	0,59	0,72	0,79	56,4
37	50	1480	92,9	93,4	93,9	0,69	0,79	0,84	71,3	1480	93,0	93,5	94,0	0,60	0,73	0,80	68,5

High-Output Design

0,75	1	1450	83,2	84,1	84,0	0,63	0,74	0,81	1,67	1460	81,8	83,8	84,6	0,55	0,68	0,76	1,62
1,1	1,5	1445	84,0	84,7	84,3	0,64	0,76	0,83	2,39	1455	82,0	84,1	84,8	0,55	0,69	0,77	2,34
1,5	2	1430	85,5	86,0	86,0	0,65	0,77	0,83	3,19	1445	85,5	86,0	86,0	0,58	0,71	0,78	3,11
2,2	3	1445	87,9	88,1	87,6	0,66	0,77	0,83	4,60	1455	87,2	88,2	88,5	0,59	0,72	0,79	4,38
5,5	7,5	1460	89,0	89,6	89,6	0,73	0,83	0,87	10,7	1465	89,4	89,6	89,8	0,65	0,78	0,84	10,1
9,2	12,5	1470	92,2	92,3	91,4	0,70	0,81	0,85	18,0	1475	91,6	92,3	92,0	0,64	0,76	0,82	17,0
11	15	1470	91,7	91,4	91,4	0,69	0,80	0,85	21,5	1475	90,6	91,4	91,5	0,61	0,74	0,81	20,6
15	20	1470	92,6	92,9	92,3	0,70	0,80	0,85	29,0	1475	92,0	92,8	92,6	0,63	0,75	0,81	27,8
18,5	25	1470	92,7	92,6	92,6	0,69	0,79	0,84	36,1	1475	91,8	92,6	92,6	0,61	0,73	0,80	34,7



W22 Brake Motor - Premium Efficiency - IE3¹

Output		Frame	Full load torque (Nm)	Locked rotor current I _L /I _n	Locked rotor torque T _L /T _n	Breakdown torque T _b /T _n	Inertia J (kgm ²)	Allowable locked rotor time (s)		Weight (kg)	Sound dB (A)	400 V							Full load current I _n (A)			
								Hot	Cold			% of full load			Rated speed (rpm)	Efficiency				Power factor		
												50	75	100		50	75	100				
VI pole - 1000 rpm - 50 Hz																						
0,12	0,16	63	1,24	3,1	2,1	2,3	0,0007	30	66	8,7	43,0	925	50,0	55,0	57,7	0,40	0,50	0,59	0,509			
0,18	0,25	71	1,91	3,2	2,0	2,1	0,0009	30	66	13,0	43,0	900	56,0	62,0	63,9	0,38	0,48	0,57	0,713			
0,25	0,33	80	2,50	4,3	1,7	2,4	0,0029	25	55	13,5	43,0	955	63,6	68,5	68,8	0,47	0,60	0,71	0,739			
0,37	0,5	80	3,82	4,5	1,9	2,1	0,0025	25	55	14,0	43,0	925	66,0	69,5	73,5	0,51	0,65	0,75	0,969			
0,55	0,75	90S	5,47	5,5	2,3	2,8	0,0055	35	77	21,5	45,0	960	77,0	77,2	77,5	0,48	0,62	0,71	1,44			
0,75	1	90L	7,62	5,2	2,5	2,8	0,0060	31	68	24,5	45,0	940	76,5	79,0	79,0	0,49	0,62	0,71	1,93			
1,1	1,5	100L	11,1	4,9	2,0	2,4	0,0110	32	70	32,5	44,0	945	80,5	81,0	81,0	0,51	0,65	0,73	2,69			
1,5	2	100L	15,1	5,5	2,3	2,8	0,0143	31	68	36,0	44,0	950	81,5	82,5	82,5	0,49	0,62	0,71	3,70			
2,2	3	112M	22,1	6,0	2,5	2,6	0,0257	26	57	52,0	52,0	950	83,0	84,5	84,5	0,53	0,64	0,72	5,22			
3	4	132S	29,7	5,8	1,8	2,6	0,0416	40	88	74,0	53,0	965	85,0	85,6	85,8	0,53	0,66	0,73	6,91			
4	5,5	132M	39,6	6,1	1,9	2,7	0,0492	25	55	79,0	53,0	965	86,0	86,8	86,8	0,53	0,66	0,73	9,11			
5,5	7,5	132M/L	54,5	7,0	2,5	2,8	0,0755	26	57	87,0	53,0	965	86,5	88,0	88,0	0,50	0,64	0,70	12,9			
7,5	10	160M	73,5	6,3	2,2	2,7	0,1404	16	35	137	56,0	975	88,5	89,3	89,3	0,64	0,76	0,82	14,8			
9,2	12,5	160L	90,2	6,5	2,3	2,9	0,1756	18	40	154	56,0	975	90,0	90,6	90,0	0,64	0,75	0,81	18,2			
11	15	160L	108	7,1	2,8	3,2	0,1931	12	26	159	56,0	975	89,0	90,1	90,5	0,60	0,73	0,80	21,9			
15	20	180L	147	7,7	2,6	3,2	0,2970	8	18	214	56,0	975	91,5	91,5	91,4	0,68	0,79	0,84	28,2			
18,5	25	200L	180	6,3	2,4	2,8	0,3510	16	35	256	60,0	980	91,0	91,7	91,9	0,63	0,75	0,81	35,9			
22	30	200L	215	6,4	2,4	2,8	0,4212	15	33	266	60,0	980	91,4	92,0	92,4	0,64	0,76	0,81	42,4			
High-Output Design																						
1,1	1,5	112M	11,0	6,2	2,3	2,8	0,0220	28	62	45,0	52,0	960	80,0	81,0	82,0	0,52	0,64	0,70	2,77			
1,5	2	112M	14,9	6,7	2,8	2,7	0,0202	28	62	48,0	52,0	965	84,5	85,5	85,5	0,51	0,63	0,71	3,57			
2,2	3	132S	21,7	5,7	1,8	2,7	0,0492	30	66	72,0	53,0	970	86,0	87,5	87,5	0,52	0,64	0,72	5,04			
VIII pole - 750 rpm - 50 Hz																						
0,12	0,16	71	1,76	2,4	1,6	1,9	0,0009	30	66	13,0	41,0	650	44,0	50,0	52,5	0,35	0,43	0,50	0,660			
0,18	0,25	80	2,53	3,3	2,0	2,2	0,0029	30	66	15,0	42,0	680	51,0	57,0	58,7	0,45	0,55	0,65	0,681			
0,25	0,33	80	3,44	3,5	2,0	2,2	0,0034	30	66	16,0	42,0	695	53,0	60,0	64,1	0,42	0,52	0,63	0,894			
0,37	0,5	90S	5,05	3,7	2,0	2,3	0,0055	30	66	21,5	43,0	700	61,0	66,0	69,3	0,41	0,53	0,62	1,24			
0,55	0,75	90L	7,62	3,8	1,9	2,2	0,0066	29	64	25,5	43,0	690	65,0	70,0	73,0	0,44	0,57	0,67	1,62			
0,75	1	100L	10,1	4,6	1,9	2,3	0,0127	30	66	34,5	50,0	710	72,5	75,5	75,5	0,41	0,53	0,62	2,31			
1,1	1,5	100L	14,8	4,6	2,1	2,4	0,0143	30	66	37,0	50,0	710	73,0	76,0	77,7	0,41	0,53	0,62	3,30			
1,5	2	112M	20,3	5,0	2,5	2,8	0,0238	28	62	49,0	46,0	705	79,0	79,5	79,9	0,45	0,59	0,68	3,98			
2,2	3	132S	29,6	6,2	2,3	2,5	0,0690	27	59	78,0	48,0	710	81,5	82,0	82,1	0,51	0,65	0,72	5,37			
3	4	132M	40,4	6,4	2,4	2,6	0,0838	21	46	84,0	48,0	710	82,5	83,5	83,5	0,51	0,64	0,72	7,20			
4	5,5	160M	52,4	5,0	2,1	2,3	0,1229	34	75	133	51,0	730	85,0	86,0	86,0	0,47	0,61	0,68	9,87			
5,5	7,5	160M	72,5	5,0	2,1	2,3	0,1492	28	62	142	51,0	725	86,0	87,3	87,3	0,52	0,65	0,73	12,5			
7,5	10	160L	98,2	5,3	2,2	2,5	0,2199	22	48	164	51,0	730	87,0	88,3	88,5	0,52	0,65	0,73	16,8			
9,2	12,5	180M	121	6,0	2,0	2,6	0,2575	15	33	202	51,0	725	89,0	89,3	89,6	0,63	0,75	0,82	18,1			
11	15	180L	144	6,5	2,3	2,7	0,2846	12	26	214	51,0	730	88,7	89,2	89,7	0,55	0,68	0,76	23,3			
15	20	200L	196	4,8	1,9	2,1	0,4571	34	75	261	56,0	730	89,0	89,6	89,8	0,56	0,68	0,74	32,6			

Note:

(1) Efficiency values are given according to IEC 60034-2-1. They are calculated according to indirect method, with stray load losses determined by measurement.

Output		380 V								415 V							
		Rated speed (rpm)	% of full load						Full load current In (A)	Rated speed (rpm)	% of full load						Full load current In (A)
			Efficiency			Power factor					Efficiency			Power factor			
kW	HP	50	75	100	50	75	100	50	75	100	50	75	100	50	75	100	
VI pole - 1000 rpm - 50 Hz																	
0,12	0,16	910	48,7	54,7	57,7	0,40	0,53	0,63	0,502	930	50,0	55,0	57,7	0,39	0,47	0,56	0,517
0,18	0,25	885	57,7	62,8	63,9	0,43	0,55	0,64	0,669	910	54,5	61,2	63,9	0,38	0,48	0,57	0,688
0,25	0,33	950	65,9	68,0	68,6	0,51	0,64	0,74	0,748	960	61,7	68,2	68,8	0,45	0,57	0,68	0,743
0,37	0,5	915	67,6	69,9	73,5	0,55	0,69	0,79	0,968	930	64,3	68,8	73,5	0,48	0,62	0,72	0,973
0,55	0,75	950	76,0	77,0	77,2	0,52	0,66	0,74	1,46	960	77,2	77,5	77,6	0,45	0,59	0,68	1,45
0,75	1	930	77,5	79,2	78,9	0,53	0,66	0,74	1,95	945	75,3	78,6	79,1	0,46	0,59	0,69	1,91
1,1	1,5	940	80,8	80,9	81,0	0,55	0,68	0,75	2,75	950	79,9	80,9	81,5	0,48	0,62	0,70	2,68
1,5	2	945	82,3	82,6	82,5	0,53	0,66	0,74	3,73	955	80,6	82,3	82,8	0,46	0,59	0,68	3,71
2,2	3	945	83,6	84,4	84,3	0,57	0,68	0,75	5,29	955	82,3	84,3	84,7	0,50	0,62	0,70	5,16
3	4	960	85,0	85,8	85,8	0,57	0,69	0,76	6,99	970	85,2	85,8	86,0	0,49	0,63	0,71	6,84
4	5,5	960	86,3	86,8	86,8	0,57	0,70	0,76	9,21	970	85,4	86,5	86,8	0,49	0,62	0,71	9,03
5,5	7,5	960	87,4	88,3	88,0	0,55	0,68	0,75	12,7	965	85,8	87,7	88,0	0,47	0,61	0,69	12,6
7,5	10	970	88,9	89,0	89,1	0,68	0,79	0,84	15,2	980	88,0	89,0	89,1	0,61	0,73	0,80	14,6
9,2	12,5	970	89,5	90,0	90,0	0,68	0,78	0,83	18,7	975	89,6	90,0	90,0	0,61	0,73	0,79	18,0
11	15	975	89,7	90,3	90,3	0,65	0,77	0,83	22,3	980	88,3	89,8	90,3	0,57	0,70	0,78	21,7
15	20	975	90,7	91,0	91,2	0,72	0,81	0,86	29,1	980	91,3	91,6	91,2	0,65	0,77	0,84	27,3
18,5	25	980	91,0	91,7	91,7	0,68	0,78	0,83	36,9	985	90,3	91,4	91,7	0,59	0,72	0,78	36,0
22	30	980	92,0	92,2	92,2	0,69	0,79	0,84	43,2	980	90,8	91,8	92,2	0,60	0,72	0,79	42,0

High-Output Design

1,1	1,5	955	80,0	81,0	82,0	0,55	0,70	0,72	2,83	960	80,0	81,0	82,0	0,48	0,62	0,68	2,74
1,5	2	960	85,1	85,4	84,9	0,54	0,66	0,74	3,63	965	84,0	85,4	85,8	0,48	0,60	0,69	3,52
2,2	3	965	86,5	87,5	87,1	0,55	0,67	0,74	5,19	973	85,6	87,4	87,7	0,48	0,61	0,70	4,99

VIII pole - 750 rpm - 50 Hz

0,12	0,16	635	46,6	51,7	52,9	0,38	0,46	0,54	0,638	655	41,8	48,2	51,4	0,34	0,41	0,48	0,677
0,18	0,25	670	52,8	58,0	58,7	0,48	0,59	0,69	0,675	685	49,3	56,0	58,7	0,43	0,53	0,62	0,688
0,25	0,33	685	54,0	60,0	64,1	0,44	0,57	0,67	0,884	705	56,0	62,0	64,3	0,39	0,50	0,60	0,902
0,37	0,5	690	61,0	66,0	69,3	0,44	0,56	0,66	1,23	710	62,0	67,0	69,5	0,38	0,50	0,59	1,26
0,55	0,75	695	65,0	70,0	73,0	0,49	0,62	0,70	1,64	705	65,0	70,0	73,0	0,42	0,55	0,64	1,64
0,75	1	705	73,9	76,1	75,1	0,44	0,57	0,66	2,30	715	71,1	74,8	75,5	0,38	0,50	0,59	2,34
1,1	1,5	700	74,9	76,8	77,7	0,45	0,58	0,66	3,26	710	71,1	76,0	77,7	0,38	0,50	0,59	3,34
1,5	2	700	79,0	79,5	79,7	0,49	0,63	0,71	4,03	710	77,9	79,7	79,9	0,42	0,56	0,65	4,02
2,2	3	705	81,5	81,9	81,9	0,57	0,68	0,76	5,37	715	81,0	82,0	82,2	0,48	0,62	0,70	5,32
3	4	705	83,4	83,5	83,5	0,56	0,68	0,75	7,28	715	81,5	83,2	83,7	0,48	0,61	0,70	7,12
4	5,5	725	85,6	86,8	86,1	0,51	0,64	0,70	10,1	735	84,4	86,6	86,8	0,44	0,58	0,66	9,71
5,5	7,5	720	86,7	87,3	87,2	0,56	0,68	0,76	12,6	730	85,2	87,0	87,8	0,49	0,62	0,71	12,3
7,5	10	725	87,8	88,5	88,6	0,56	0,69	0,76	16,9	730	86,2	88,0	88,9	0,49	0,62	0,71	16,5
9,2	12,5	720	89,2	89,1	88,9	0,67	0,78	0,84	18,7	730	88,6	89,3	90,0	0,60	0,73	0,80	17,8
11	15	725	88,5	89,0	89,5	0,59	0,71	0,77	24,3	730	89,0	89,5	90,0	0,52	0,65	0,74	23,0
15	20	730	90,5	91,0	91,0	0,60	0,71	0,76	33,0	730	89,0	89,6	89,8	0,53	0,65	0,72	31,7

Mechanical Data (Standard)

Motors with Top Mounted Terminal Box

Frames 63 to 132M/L*

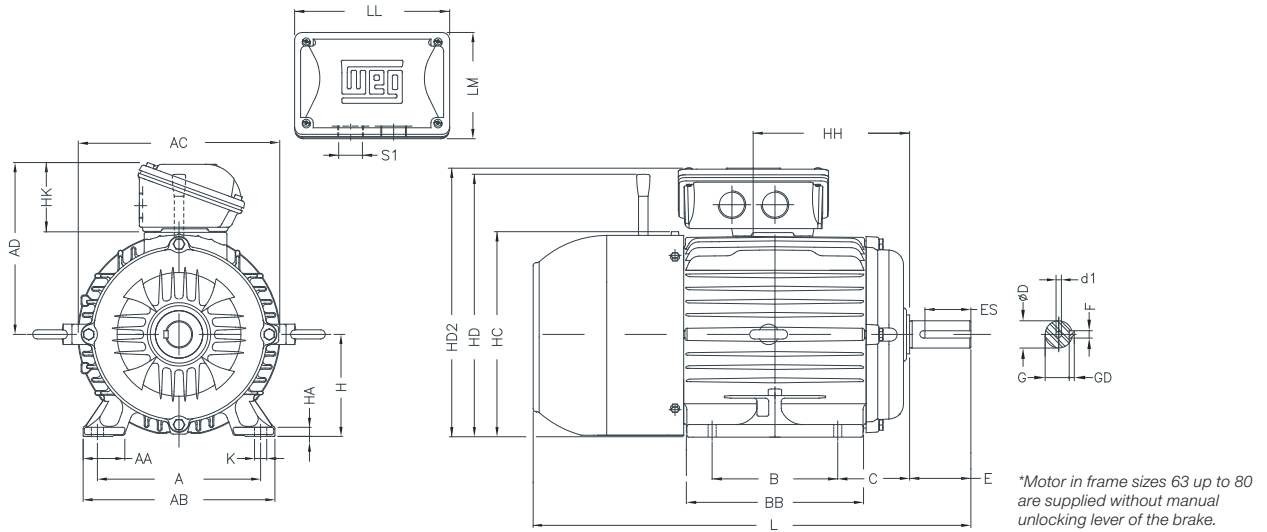

Frames 160M to 200L

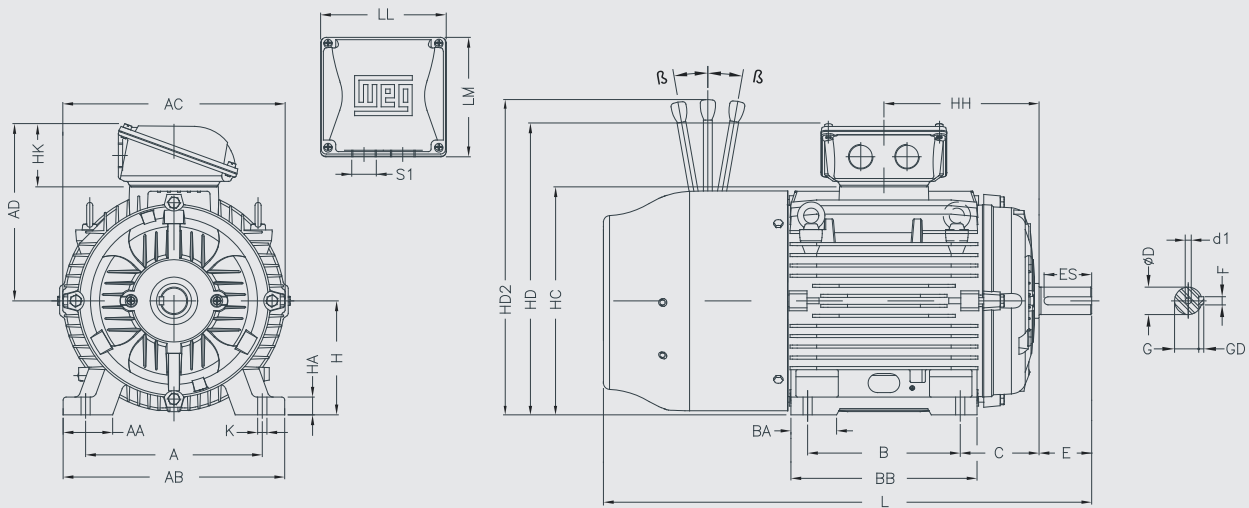

Frames 225S/M to 250S/M

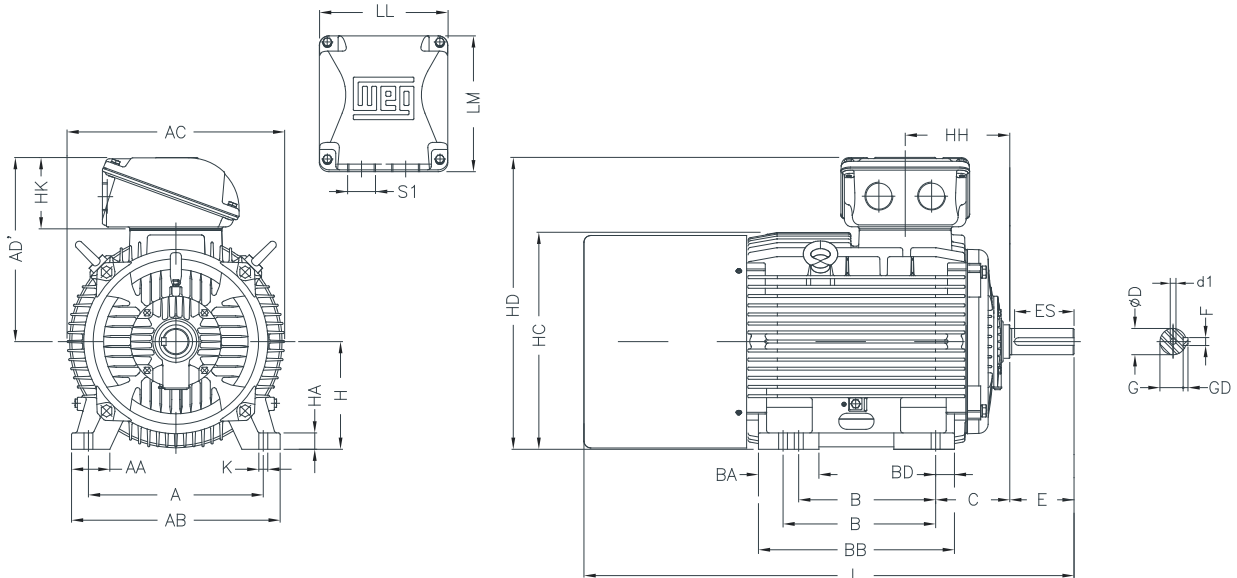

Frame	Front View									Terminal Box Detail			Bearings	
	A	AA	AB	AC	AD and AD'	H	HA	HK	K	LL	LM	S1	DE	NDE
63	100	25,5	116	125	132	63	7	69	7	150	110	2xM20x1,5	6201-ZZ	6201-ZZ
71	112	28,5	132	141	140	71	7	69	7	150	110	2xM20x1,5	6202-ZZ	6202-ZZ
80	125	30,5	149	159	148	80	8	69	10	150	110	2xM20x1,5	6204-ZZ	6203-ZZ
90S	140	37	164	179	157	90	9	69	10	150	110	2xM25x1,5	6205-ZZ	6204-ZZ
90L	140	37	164	179	157	90	9	69	10	150	110	2xM25x1,5		
100L	160	40	188	199	170	100	10	69	12	150	110	2xM25x1,5	6206-ZZ	6205-ZZ
112M	190	40,5	220	215	191	112	10	77	12	167	138	2xM32x1,5	6207-ZZ	6206-ZZ
132S	216	45,5	248	272	218	132	16	77	12	167	138	2xM32x1,5	6308-ZZ	6207-ZZ
132M	216	45,5	248	272	218	132	16	77	12	167	138	2xM32x1,5		
132M/L	216	45,5	248	272	218	132	16	77	12	167	138	2xM32x1,5	6309-C3	6209-C3
160M	254	64	308	329	266	160	22	101	14,5	198,5	190	2xM40x1,5		
160L	254	64	308	329	266	160	22	101	14,5	198,5	190	2xM40x1,5	6311-C3	6211-C3
180M	279	78	350	360	281	180	28	101	14,5	198,5	190	2xM40x1,5		
180L	279	78	350	360	281	180	28	101	14,5	198,5	190	2xM40x1,5	6312-C3	6212-C3
200M	318	82	385	402	319	200	30	119,5	18,5	230	220	2xM50x1,5		
200L	318	82	385	402	319	200	30	119,5	18,5	230	220	2xM50x1,5	6314-C3	6314-C3
225S/M	356	80	436	455	410	225	34	153	18,5	269	285	2xM50x1,5		
250S/M	406	100	506	486	410	250	43	153	24	269	285	2xM63x1,5		

Frame	Left Side View											Shaft End Detail						
	B	BA	BB	BD	C	HC	HD	HD2	HH	β	L	D	d1	E	ES	F	G	GD
63	80	-	95	-	40	130	156,3	170	80	12°	260	11j6	EM4	23	14	4	8,5	4
71	90		113,5		45	145	163,8	207	90	10°	300	14j6	DM5	30	18	5	11	5
80	100		125,5		50	163	174,3	215	100									
90S	100		131		56	182	182,4	222	106	9°	376	24j6	DM8	50	36	8	20	7
90L	125		156		56	182	182,4	222	118,5									
100L	140		173		63	205	244	262	133	10°	460	28j6	DM10	60	45	8	24	7
112M	140		177		70	226	280	306	140	9°	482	28j6	DM10	60	45	8	24	7
132S	140		187		89	274	319	371	159									
132M	178		225		89	274	319	371	178	10°	580	38k6	DM12	80	63	10	33	8
132M/L	178/203		250		89	274	319	371	190,5									
160M	210		63		108	331	374	438	213	9°	722	42k6	DM16	110	80	12	37	8
160L	254		63		108	331	374	438	235									
180M	241		70		121	366	413	498	241,5	10°	793	48k6	DM16	110	80	14	42,5	9
180L	279		70		121	366	413	498	260,5									
200M	267		82		133	407	464	644	266,5	10°	858	55m6	DM20	110	80	16	49	10
200L	305		82		133	407	464	644	285,5									
225S/M	286/311	124	149	453	541	-	212	-	1069	60m6	DM20	140	125	18	53	11		
250S/M	311/349	146	168	493	583	-	214	-	1183	65m6	DM20	140	125	18	58	11		



Motors with Side Mounted Terminal Box

Frames 63 to 132M/L

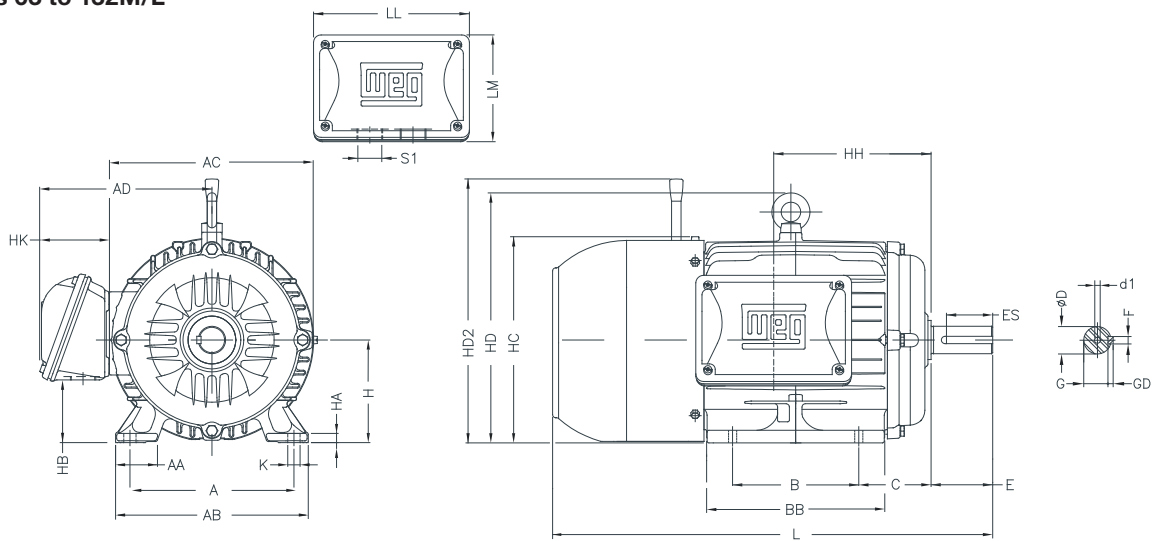

Frames 160M to 200L

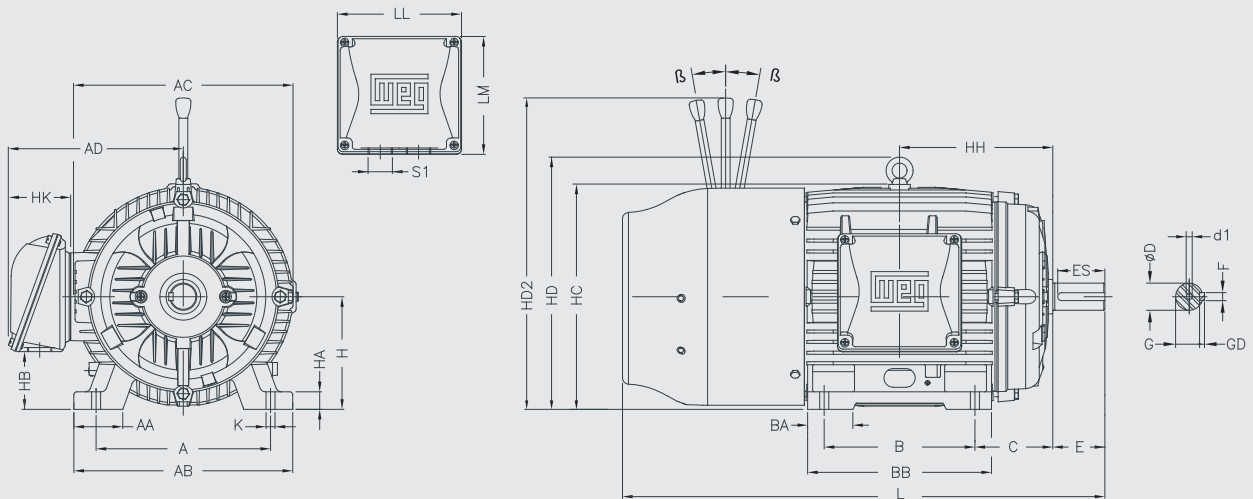

Frames 225S/M to 250S/M

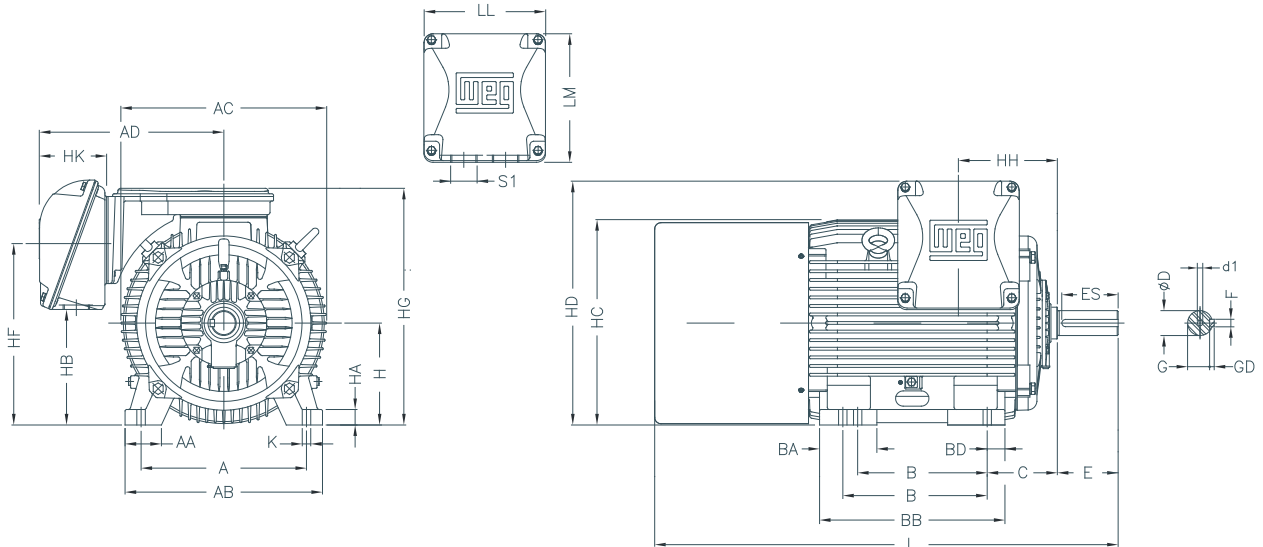

Frame	Front View										Terminal Box Detail			Bearings	
	A	AA	AB	AC	AD and AD'	H	HA	HB	HK	K	LL	LM	S1	DE	NDE
63	100	25,5	116	125	132	63	7	23,5	69	7	150	110	2xM20x1,5	6201 ZZ	6201 ZZ
71	112	28,5	132	141	140	71	7	31	69	7	150	110	2xM20x1,5	6202 ZZ	6202 ZZ
80	125	30,5	149	159	148	80	8	41,5	69	10	150	110	2xM20x1,5	6204 ZZ	6203 ZZ
90S	140	37	164	179	157	90	9	45	69	10	150	110	2xM25x1,5	6205 ZZ	6204 ZZ
90L	140	37	164	179	157	90	9	45	69	10	150	110	2xM25x1,5	6205 ZZ	6204 ZZ
100L	160	40	188	199	170	100	10	61,5	69	12	150	110	2xM32x1,5	6206 ZZ	6205 ZZ
112M	190	40,5	220	215	191	112	10	54	77	12	167	138	2xM32x1,5	6207 ZZ	6206 ZZ
132S	216	45,5	248	272	218	132	16	74	77	12	167	138	2xM32x1,5	6308 ZZ	6207 ZZ
132M	216	45,5	248	272	218	132	16	74	77	12	167	138	2xM32x1,5	6308 ZZ	6207 ZZ
132M/L	216	45,5	248	272	218	132	16	74	77	12	167	138	2xM40x1,5	6308 ZZ	6207 ZZ
160M	254	64	308	329	266	160	22	79	101	14,5	198,5	190	2xM40x1,5	6309 C3	6209 Z-C3
160L	254	64	308	329	266	160	22	79	101	14,5	198,5	190	2xM40x1,5	6309 C3	6209 Z-C3
180M	279	78	350	360	281	180	28	92	101	14,5	198,5	190	2xM40x1,5	6311 C3	6211 Z-C3
180L	279	78	350	360	281	180	28	92	101	14,5	198,5	190	2xM50x1,5	6311 C3	6211 Z-C3
200M	318	82	385	402	319	200	30	119	119,5	18,5	230	220	2xM50x1,5	6312 C3	6212 Z-C3
200L	318	82	385	402	319	200	30	119	119,5	18,5	230	220	2xM50x1,5	6312 C3	6212 Z-C3
225S/M	356	80	436	455	410	225	34	254	153	18,5	269	285	2xM63x1,5	6314 C3	6314 C3
250S/M	406	100	506	486	410	250	43	297	153	24	269	285	2xM63x1,5	6314 C3	6314 C3

Frame	Left Side View										Shaft End Detail							
	B	BA	BB	BD	C	HC	HD	HD2	HH	β	L	D	d1	E	ES	F	G	GD
63	80		95		40	130	156,3	170	80	12°	260	11j6	A 3,15	23	14	4	8,5	4
71	90		113,5		45	145	163,8	207	90	10°	300	14j6	A 3,15	30	18	5	11	5
80	100		125,5		50	163	174,3	215	100		335	19j6	A 3,15	40	28	6	15,5	6
90S	100		131		56	182	182,4	222	106	9°	376	24j6	A 4	50	36	8	20	7
90L	125		156		56	182	182,4	222	118,5		401	24j6	A 4	50	36	8	20	7
100L	140		173		63	205	244	262	133	10°	460	28j6	A 4	60	45	8	24	7
112M	140		177		70	226	280	306	140		542	28j6	A 4	60	45	8	24	7
132S	140		187		89	274	319	371	159	10°	580	38k6	A 4	80	63	10	33	8
132M	178		225		89	274	319	371	178		605	38k6	A 4	80	63	10	33	8
132M/L	178/203		250		89	274	319	371	190,5	9°	722	42k6	A 4	110	80	12	37	8
160M	210	63	254		108	331	374	438	213		766	42k6	A 4	110	80	12	37	8
160L	254	63	298		108	331	374	438	235	10°	793	48k6	A 4	110	80	14	42,5	9
180M	241	70	294		121	366	413	498	241,5		831	48k6	A 4	110	80	14	42,5	9
180L	279	70	332		121	366	413	498	260,5	10°	858	55m6	A 4	110	80	16	49	10
200M	267	82	332		133	407	464	644	266,5		896	55m6	A 4	110	80	16	49	10
200L	305	82	370		133	407	464	644	285,5	-	1069	60m6	DM20	140	125	18	53	11
225S/M	286/311	124	412	41	149	453	541	-	212		1183	65m6	DM20	140	125	18	58	11
250S/M	311/349	146	467	59	168	493	583	-	214	-	-	-	-	-	-	-	-	-



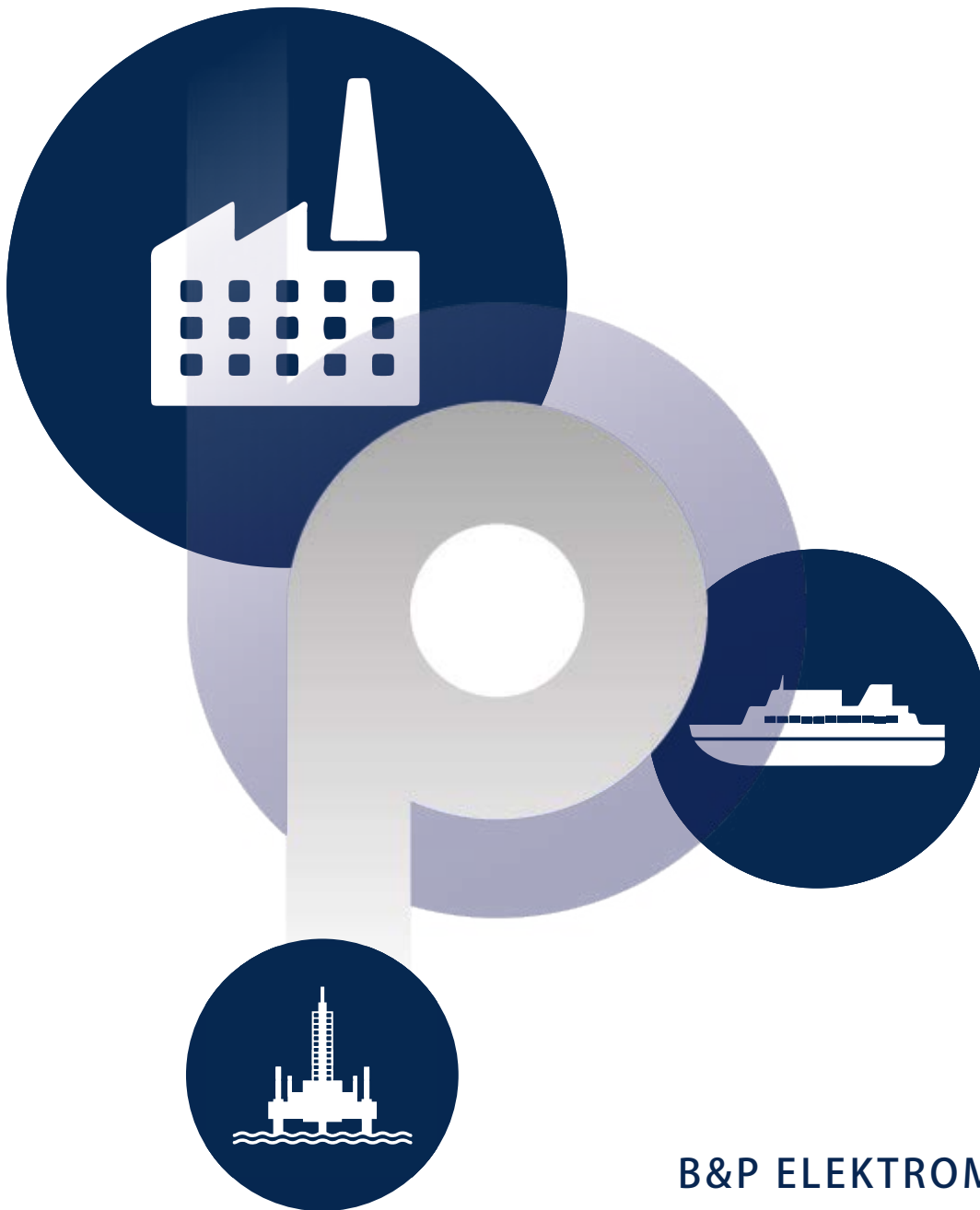

B&P ELEKTROMOTOREN BV

Ampèrestraat 8F
4004 KB Tiel

info@bnpelektromotoren.nl

+31 (0)344 616 267

BTW nr. NL819113918B01

KvK nr. 30237800

ING Bank NL60 INGB 0675 304 792



www.bnpelektromotoren.nl