



B&P Elektromotoren

W22

Single-Phase Electric Motor

Commercial Catalogue
European Market

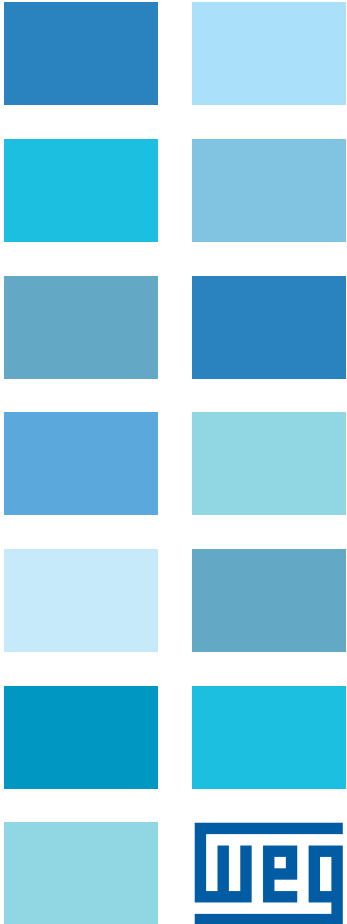
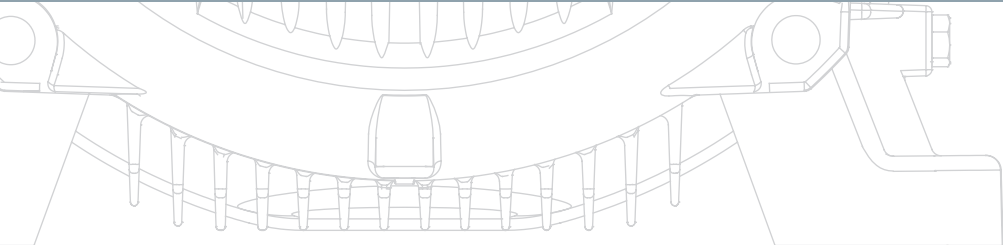
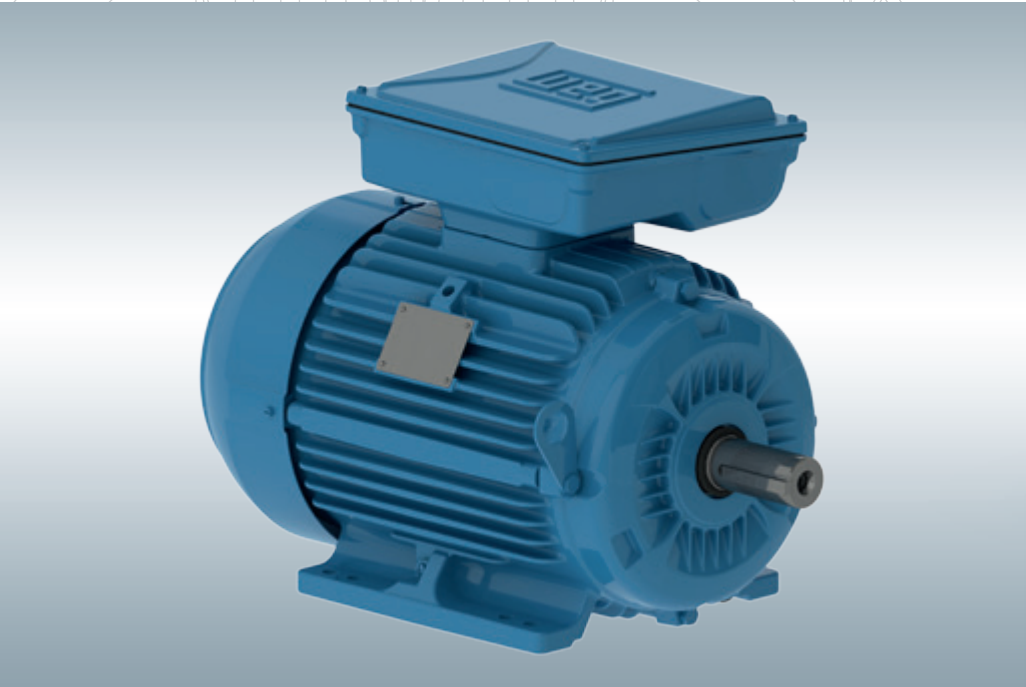
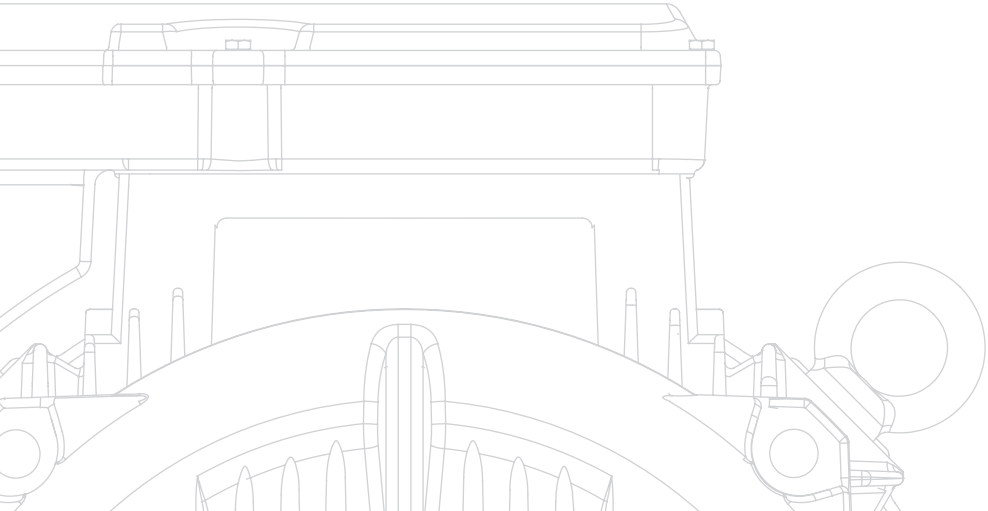

Exploded View

Cooling System

- The cooling system (fan, non drive end-shield and fan cover) is designed to minimize noise level and improve thermal efficiency
- Steel plate fan cover provides high mechanical strength, corrosion resistance and extended lifetime

Capacitor

- With start and run capacitors

Nameplate

- Stainless steel nameplate detailing complete and permanent record of all motor data

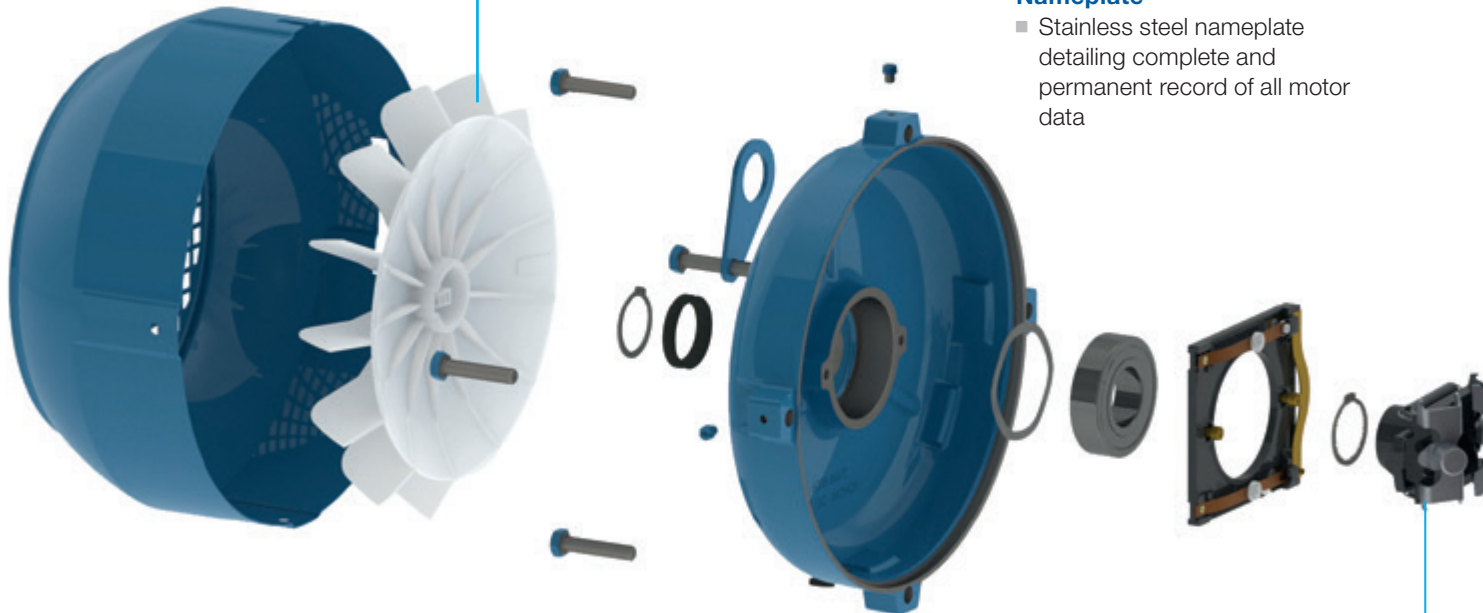

Centrifugal Switch

- The starting system of W22 single phase motors was completely redesigned to improve functionality, thus increasing system reliability and lifespan.



Terminal Block

- Terminal block in polyester based resin BMC (Bulk Moulding Compound) duly reinforced with fibre glass



Stator Wound

- Low loss magnetic steel laminations, thermally and chemically treated to improve efficiency and minimize mechanical stress
- Windings with class 'H' enamelled wire, impregnated with solvent free polyester resin

Shaft

- AISI 1040/45 carbon steel providing high mechanical strength and minimizing bending under load and fatigue

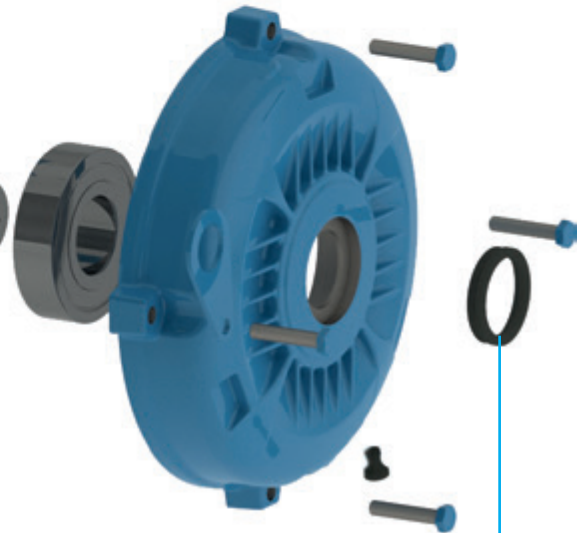

Cast Iron Frame

- FC-200 (EN GJL 200) cast iron frames meeting impact level IK08 (5J) ensuring superior mechanical strength for the most demanding applications
- Solid motor feet providing excellent rigidity, allowing easier alignment and installation

V-Ring Seals

- V-Ring seals to prevent ingress of liquids and dust into the motor

Features

- High starting torque
- Suitable for domestic and rural power supply conditions
- Adaptable design suitable for a variety of applications and needs

Standard

- Rated output: 0,18 kW up to 9,2 kW
- Number of poles: 2 and 4
- Frame sizes: 63 up to 132M/L
- Voltage: 230 V or 230/460 V
- Frequency: 50 Hz
- Degree of protection: IP55
- Painting plan: 207A
- Frame material: Cast iron
- Mounting: B3T
- Cooling method: Totally enclosed fan cooled
- Grounding: Single (inside the terminal box)
- Fan material: Polypropylene
- Shaft material: AISI 1040/45 Carbon steel
- Nameplate material: Stainless steel
- Colour: Blue RAL 5009
- Insulation class: F
- Service factor: 1.00

Optional

- Voltage: 110 V, 220 V, 240 V etc.
 - Insulation class: H
 - Degree of Protection: IP56 and above
 - Frequency: 60 Hz
 - Thermal protection
 - Other mounting forms / terminal box positions
 - Stainless steel shaft
 - Undersized terminal box (For frames 90L and 100L)*
- *Only by request

Applications

- Fans and Blowers
- Grain Driers
- Centrifugal pumps
- Compressors
- High Pressure Washers
- Silo Unloaders and Augers
- Conveyors / Materials Handling
- Silo unloaders
- Grinding Machines



Electrical Data

W22 Single-Phase - CSR (Starting and Run Capacitor) - Starting torque beginning from 170%

Output		Frame	Full load torque (Nm)	Locked rotor current II/In	Locked rotor torque TI/Tn	Breakdown torque Tb/Tn	Inertia J (kgm ²)	Allowable locked rotor time (s)	Weight (kg)	Sound dB (A)	Rated speed (rpm)	% of full load						Full load current In (A)	
												Efficiency (%)			Power factor				
												kW	HP	50	75	100	50	75	100
II pole - 50 Hz																			
0,18	0,25	63	0,595	6,5	2,6	2,5	0,0002	5	10,3	47	2890	37,2	47,8	54,5	0,82	0,88	0,90	1,60	0,800
0,25	0,33	63	0,832	5,8	2	2,1	0,0002	5	10,5	47	2870	43,1	53,6	59,5	0,76	0,85	0,95	1,93	0,966
0,37	0,5	71	1,21	8,5	3	2,9	0,0005	6	13,0	57	2930	55,1	64,7	69,5	0,72	0,82	0,86	2,70	1,35
0,55	0,75	71	1,80	7,5	2,2	2,5	0,0006	5	13,5	57	2920	56,9	66,6	71,5	0,87	0,94	0,97	3,45	1,73
0,75	1	80	2,46	7,6	2,3	2,6	0,0010	9	18,0	62	2915	63,9	71,7	75,0	0,79	0,87	0,91	4,78	2,39
1,1	1,5	80	3,65	6,3	2,4	2	0,0011	6	19,0	62	2880	69,9	75,2	76,0	0,74	0,85	0,91	6,92	3,45
1,5	2	90S	4,94	7,3	2	2,2	0,0022	7	24,0	66	2900	73,9	79,2	80,0	0,89	0,94	0,94	8,68	4,34
2,2	3	90L	7,26	6,8	2,3	2,1	0,0028	6	27,0	66	2895	75,5	80,0	80,0	0,94	0,97	0,96	12,5	6,25
3	4	100L	9,90	6,7	2,1	2,2	0,0070	6	40,0	69	2895	74,9	80,1	81,0	0,89	0,95	0,96	16,8	8,40
3,7	5	112M	12,1	8,0	2,4	2,5	0,0095	6	48,5	69	2910	82,0	85,2	85,0	0,95	0,97	0,99	19,1	9,55
5,5	7,5	132M	18,1	7,7	2,4	2,6	0,0234	6	71,0	69	2900	80,7	84,7	85,0	0,95	0,97	0,99	28,4	14,2
7,5	10	132M	24,5	9,0	2,1	3,1	0,0288	6	80,0	69	2920	82,7	85,8	86,0	0,94	0,96	0,97	39,0	19,5
9,2	12,5	132M/L	30,1	8,5	1,7	2,9	0,0342	6	88,5	69	2920	86,1	88,3	88,0	0,99	0,99	0,99	45,9	23,0
IV pole - 50 Hz																			
0,18	0,25	71	1,19	5,8	3,8	2,6	0,0008	12	13,2	53	1450	38,8	49,0	55,5	0,61	0,69	0,75	1,91	0,957
0,25	0,33	71	1,66	6,4	4	2,3	0,0009	9	13,7	53	1440	42,7	53,0	59,0	0,71	0,78	0,80	2,30	1,15
0,37	0,5	71	2,49	5,9	3,1	2	0,0009	16	14,1	53	1420	53,0	62,5	67,0	0,80	0,86	0,89	2,70	1,35
0,55	0,75	80	3,61	6,6	2,1	2,6	0,0030	7	18,3	53	1455	52,2	61,7	66,5	0,60	0,71	0,78	4,61	2,30
0,75	1	80	4,99	6,5	2,1	1,9	0,0032	6	18,7	53	1435	61,0	68,3	70,0	0,80	0,89	0,92	5,06	2,53
1,1	1,5	90S	7,29	6,6	2	2,07	0,0055	9	25,5	56	1441	63,1	70,8	73,5	0,93	0,96	0,97	6,70	3,35
1,5	2	90L	9,95	7,2	2,4	2,1	0,0066	7	28,0	56	1440	65,8	73,3	75,5	0,91	0,96	0,96	4,70	4,50
2,2	3	100L	14,5	6,7	2	2,2	0,0097	10	38,5	56	1450	73,9	79,5	77,5	0,87	0,92	0,93	13,2	6,65
3	4	112M	20,0	6,7	2,4	2,4	0,0164	9	49,0	58	1430	72,4	78,0	78,5	0,84	0,91	0,93	17,9	8,95
3,7	5	132M	24,5	6,9	2,3	2,6	0,0357	8	67,0	61	1445	68,5	75,6	78,5	0,86	0,91	0,94	21,8	10,9
5,5	7,5	132M	36,2	8,0	2,9	2,6	0,0543	7	82,2	61	1450	73,8	79,7	81,5	0,96	0,98	0,97	30,0	15,0
7,5	10	132M*	49,6	7,3	2,7	2,7	0,0543	11	86,5	61	1445	79,7	83,7	83,0	0,85	0,91	0,93	42,2	21,0
High-Output Design																			
3,7	5	112M*	24,8	6,3	2,2	2,2	0,0184	7	51,0	58	1425	72,5	78,2	78,5	0,95	0,97	0,97	21,0	10,5

Notes:

- (*) Motor with class F (105 K) temperature rise.
- (**) Values subjected to change without previous advise.



Mechanical Data

Frames 63 up to 90S

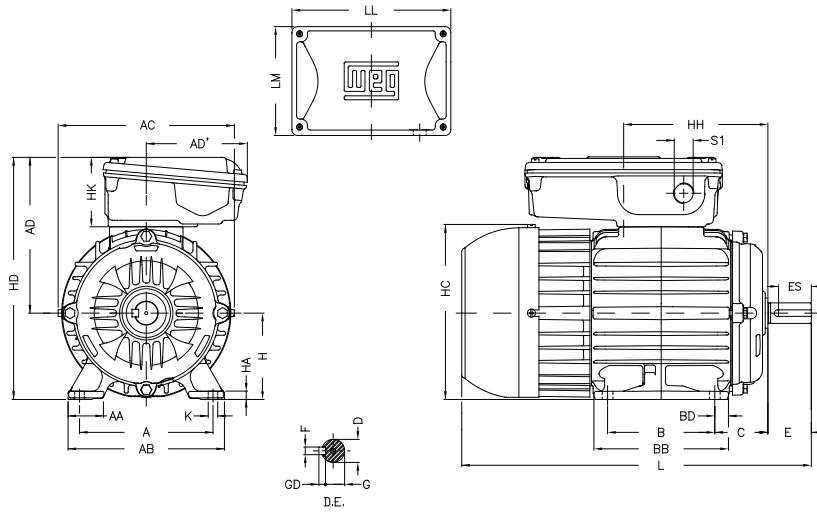

Frames 90L and 100L

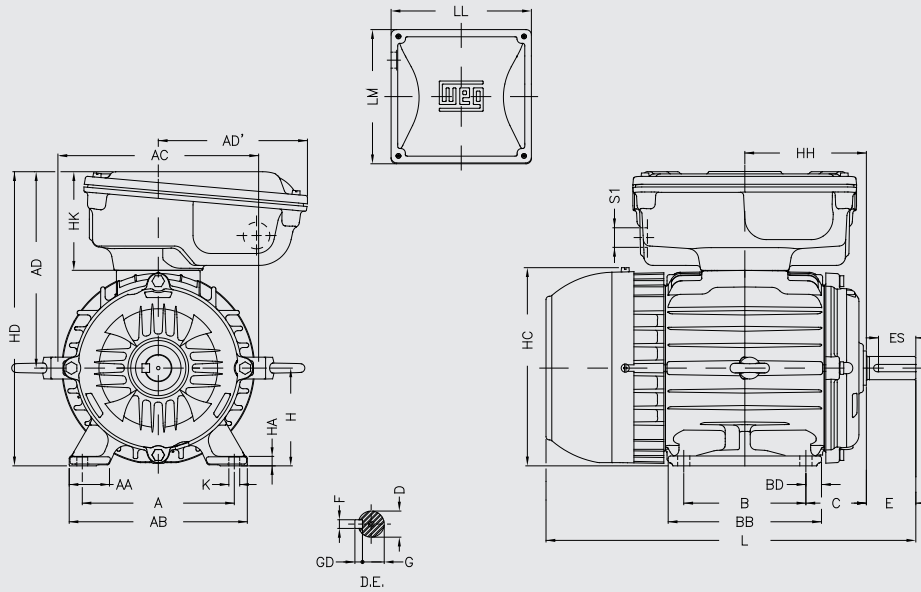

Frames 112M up to 132M/L

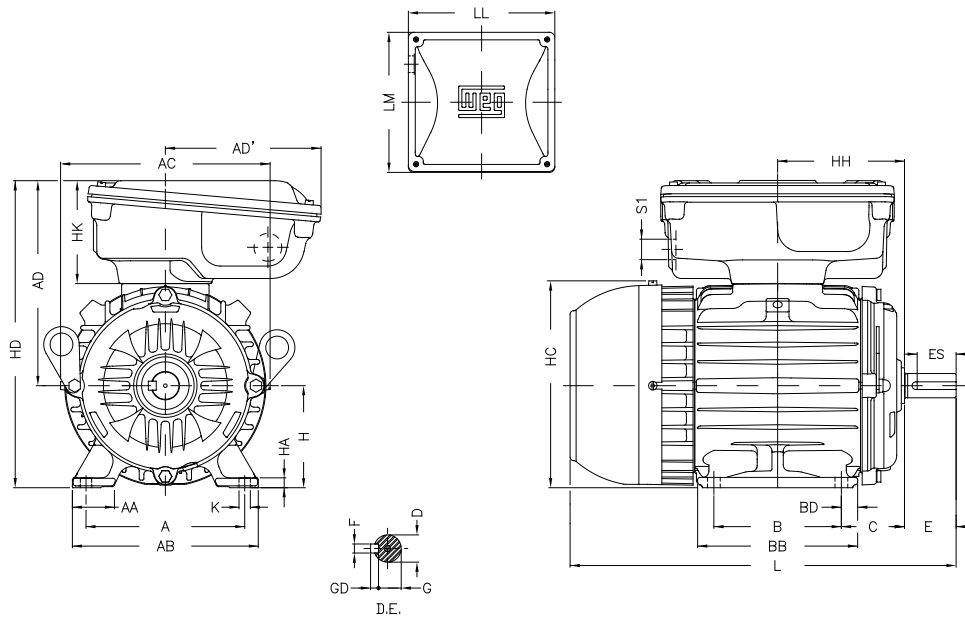

Frame	A	AA	AB	AC	AD	AD'	B	BB	BD	C	Shaft					
											D	E	ES	F	G	GD
63	100	25.5	116	125	128	95	80	95	7.5	40	11j6	23	14	4	8.5	4
71	112	28.5	132	141	136	93	90	113.5	11.75	45	14j6	30	18	5	11	5
80	125	30.5	149	159	145	94	100	125.5	12.75	50	19j6	40	28	6	15.5	6
90S	140	37	164	184	155	88		131	15.5	56	24j6	50	36	8	20	7
90L					181	137	156									
100L	160	40	188	206	191	144	140	173	16.5	63	28j6	60	45	8	24	7
112M	190	40.5	220	227	206	177		18.5	70							
132M	216	45.5	248	274	234	154	178	225	23.5	89	38k6	80	63	10	33	8
132M/L							178/203	250								

Frame	H	HA	HC	HD	HH	HK	K	L	LL	LM	S1	Bearing	
												DE	NDE
63	63	7	130	156	80	65	7	256	184	135	M20	6201-ZZ	6203-ZZ
71	71		145	164	90			293				6202-ZZ	
80	80		8	163	174			100				326	
90S	90	9	182	227	106	91	10	334	221	206	M25	6205-ZZ	6206-ZZ
90L					118.5			358				6206-ZZ	
100L	100	10	205	244	133	94	12	418	246	232	M32	6207-ZZ	6206-ZZ
112M	112		226	280	140			423				246/286'	
132M	132	16	274	319	178	94	12	489	246/286'	232	M32	6308-ZZ	6206-ZZ
132M/L					190.5			514					

Notes:

1) Motor with 5 capacitors.

“FF” Flange

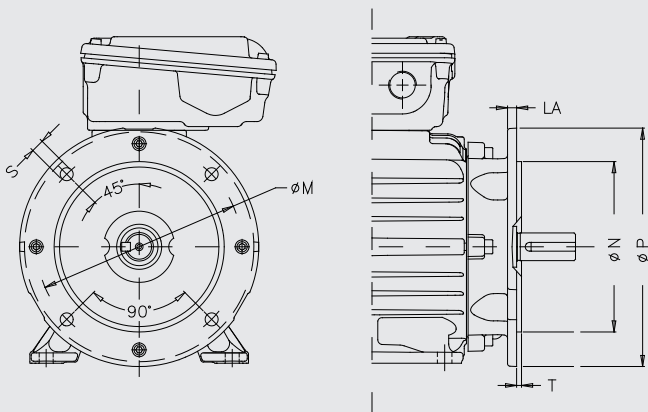

“FF” Flange									
Frame	Flange	LA	M	N	P	S	T	α	N° of holes
63	FF-115	5,5	115	95	140	10	3	45°	4
71	FF-130	7	130	110	160		3,5		
80	FF-165	9	165	130	200	12			
90		10							
100	FF-215	12,5	215	180	250	15	4		
112	FF-265	12	265	230	300				

“C-DIN” Flange

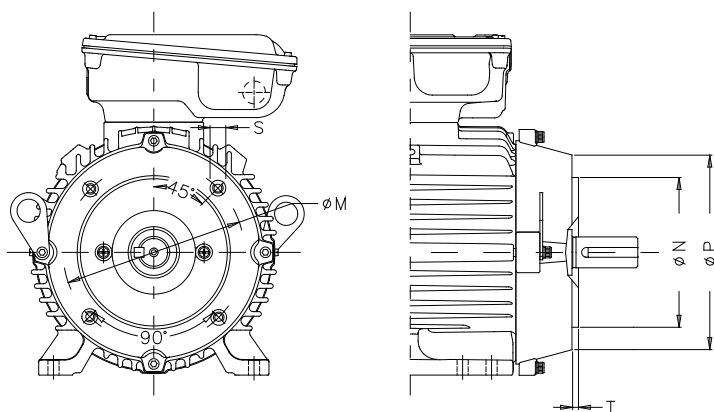

“C-DIN” Flange									
Frame	Flange	M	N	P	S	T	α	N° of holes	
63	C-90	75	60	90	M5	2,5	45°	4	
71	C-105	85	70	105	M6				
80	C-120	100	80	120	M8	3			
90	C-140	115	95	140					
100	C-160	130	110	160	M10	3,5			
112	C-200	165	130	200					

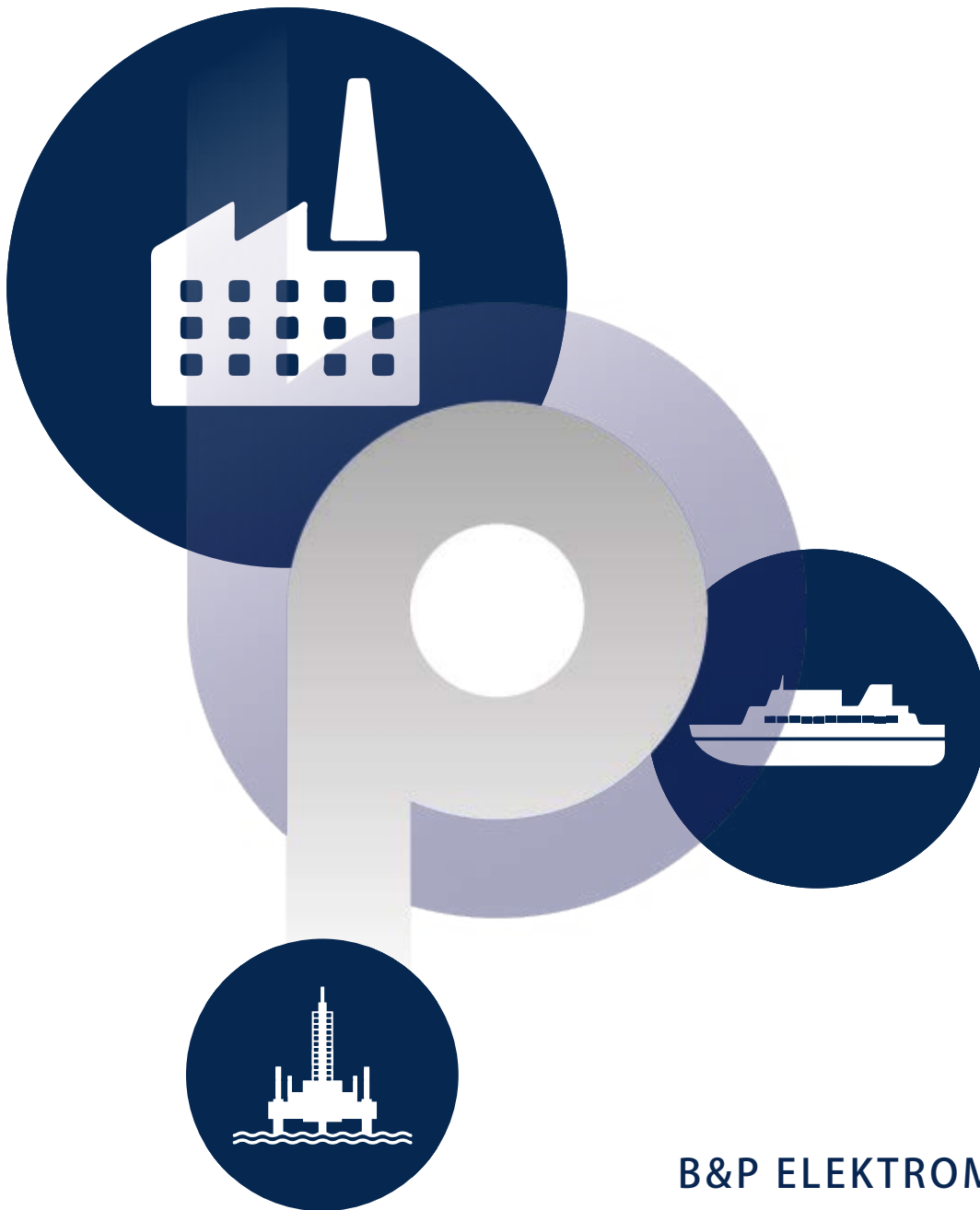

B&P ELEKTROMOTOREN BV

Ampèrestraat 8F
4004 KB Tiel

info@bnpelektromotoren.nl

+31 (0)344 616 267

BTW nr. NL819113918B01

KvK nr. 30237800

ING Bank NL60 INGB 0675 304 792



www.bnpelektromotoren.nl