



B&P Elektromotoren

Driving efficiency and sustainability



WEEM / Emerald eZA Three-Phase Motors

Installation, Operation and
Maintenance Manual



Read carefully this manual before installing and configuring the equipment

The objective of this manual is to provide important information, which must be considered during the shipment, storage, installation, operation and maintenance of WEG motors. Therefore, we advise to make a careful and detailed study of the instructions contained herein before performing any procedures on the motor. The noncompliance with the instructions informed in this manual and others mentioned on the website www.weg.net voids the product warranty and may cause serious personal injuries and material damages. For further information or explanations, check our FAQ at www.weg.net/br/faq.

The instructions presented in this document are valid for: WECM / Emerald eZA products.

1. GENERAL INFORMATION

WECM / Emerald eZA product is an Electronically Commutated Motor composed by a permanent magnet motor and a drive with features customized for commercial ventilation solutions.

This Manual contains only the required information that allows qualified and trained personnel to carry out their services. The product images are shown for illustrative purpose only.

1.1. WARNINGS IN THIS MANUAL

**DANGER!**

The procedures recommended in this warning have the purpose of protecting the user against death, serious injuries and considerable material damage.

**ATTENTION!**

The procedures recommended in this warning have the purpose of avoiding material damage.

**ATTENTION!**

The information mentioned in this warning is important for the proper understanding and good operation of the product.

2. SAFETY MEASURES

Only trained personnel, with proper qualifications, and familiar with this kind of equipment and associated machinery shall plan and implement the installation, starting, operation and maintenance of this equipment. The personnel shall follow all the safety instructions described in this manual and/ or defined by the local regulations.

**ATTENTION!**

Any service on the internal parts of the motor must be performed by qualified personnel only, since, due to the attraction between metallic parts caused by the magnets, risk of accident is present both in the assembly and disassembly of the motor.

**ATTENTION!**

Contains permanent magnets. For pacemaker users, it is recommended to avoid close or prolonged contact with this product, as it may interfere with the proper operation of the device.

**DANGER!**

Always disconnect the main power supply before touching any electrical device associated with the product. Several components may remain charged with high voltage and/or in movement and may cause injuries to people, even after the AC power supply has been disconnected or turned off. Wait at least 10 minutes to guarantee the fully discharge of capacitors. Always connect the equipment to the ground protection (PE)

3. SHIPMENT, STORAGE AND HANDLING

Check the conditions of the motor immediately upon receipt. Where any damage is noticed, this must be reported in writing to the transportation company, and immediately communicated to the insurance company and to WEG. In this case, no installation job can be started before the detected problem has been solved.

Check if the nameplate data matches the invoice data and the environmental conditions in which the motor will be installed. If the motor is not immediately installed, it must be stored in a clean and dry room protected against dust, vibrations, gases and corrosive agents, and with temperature between -25 °C and 60 °C and relative humidity not exceeding 60%.

If the motors are stored for more than two years, it is recommended to change the bearings, or to remove, wash, inspect and relubricate them before the motor is started.

**DANGER!**

■ Always handle the motor carefully in order to prevent personal injuries and impacts that could damage the bearings.

■ When available, do not lift and/or carry the product holding by the input cables.

■ When available, use only the eyebolts to lift the motor. However, these eyebolts are designed for the motor weight only. Thus, never use these eyebolts to lift the motor with additional loads coupled to it. For multimounting motors (with removable feet/ base), the eyebolts must be positioned according to the motor mounting position so that the lifting angle is vertically aligned (lifting at 0°).

■ Additional information regarding the maximum allowable angle-of-inclination is indicated in the general manual available on the website www.weg.net.

4. IDENTIFICATION LABELS

There is one nameplate with general product information on the WECM / Emerald eZA product that is affixed to the side of the motor frame and one label with basic electronic information that is affixed to the drive (back cover).

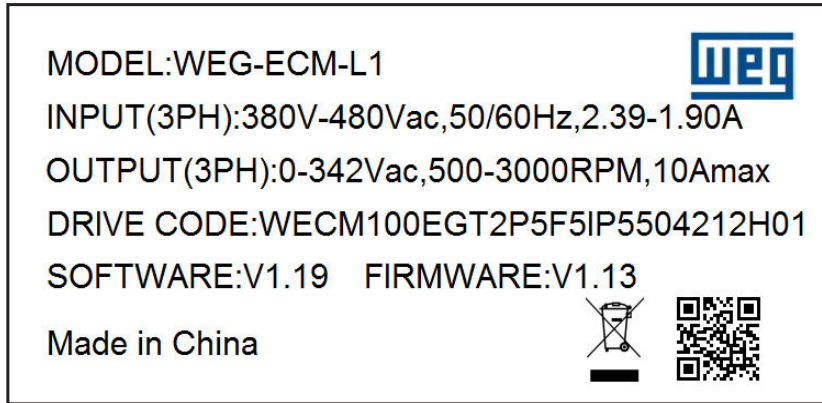

Figure 1 - Drive label

	Electronically Commutated Motor		Jan.2022												
15704328	Model AL100-60B1	Batch No#000*****													
3PH 50/60HZ IEC100 IP55 S1 INS CL F Δ T 80 K IE5 SF1.0 EP															
V	kW	Nm	RPM												
380-480	4.0	12.7	3000												
		A	EFF												
		7.58-6.00	88.7%												
		TEAO	40°C												
Control signals Common: GND PWM[10-95%]:PWM DC voltage[2-10V]:VSP 10VDC source:10V DC current[4-20mA]:ISP RS485:485R,485T,GND 24VDC source:24V Speed feedback:REF		Power input Line: L1,L2,L3 PE:green screw Alarm relay: NO,NC,COM	Local speed adjust SW1:speed down/off SW2:speed up/on * looking from DE												
		<table border="1" style="width: 100%; border-collapse: collapse;"> <tr> <td>DIP Switch</td> <td>POS</td> <td>On</td> <td>Off</td> </tr> <tr> <td>Rotation</td> <td>1</td> <td>CCW</td> <td>CW</td> </tr> <tr> <td>Control</td> <td>2</td> <td>Local</td> <td>Remote</td> </tr> </table>	DIP Switch	POS	On	Off	Rotation	1	CCW	CW	Control	2	Local	Remote	
DIP Switch	POS	On	Off												
Rotation	1	CCW	CW												
Control	2	Local	Remote												
WARNING: refer to motor manual before applying power															

Figure 2 - Europe market motor nameplate

5. INSTALLATION



DANGER!

- Make sure the AC power supply is disconnected and protected against accidental energization before starting the installation;
- Check the motor direction of rotation, turning it without load before it is coupled to the load;
- To prevent accidents, ensure that the grounding connection has been performed according to the applicable standards and that the shaft key has been securely fastened before the motor is started;
- When available, do not lift and/or carry the product holding by the input cables.

Motors must be only installed in places compatible with their mounting features and in applications and environments for which they are intended.

Those motors with feet must be installed on bases duly planned in order to prevent vibrations and assure perfect alignment. The motor shaft must be properly aligned with the shaft of the driven machine. Incorrect alignment, as well as improper belt tension, will certainly damage the bearings, resulting in excessive vibrations and even causing the shaft to rupture. The admissible shaft radial and axial loads for standard bearings are specified on the Table 1 and Table 2. Use flexible coupling whenever possible.

Allowed loads for WECM (IEC 80) motors, according maximum speed:

Direction	Mounting position	Type	1500 rpm	1800 rpm	3000 rpm
			Force (kN)	Force (kN)	Force (kN)
Axial ¹⁾	Horizontal	Pushing	0.90	0.86	0.74
		Pulling	0.50	0.46	0.34
	Vertical shaft down	Pushing	0.96	0,91	0.77
		Pulling	0.47	0.44	0.33
	Vertical shaft up	Pushing	0.87	0.84	0.73
		Pulling	0.56	0.51	0.37
Radial ²⁾	All	L	0.66	0.61	0.49
		L/2	0.74	0.69	0.56

Table 1 - Maximum permissible thrust - Fr in (kN) 20000 hours

Allowed loads for WECM (IEC 100) motors, according maximum speed:

Direction	Mounting position	Type	1500 rpm	1800 rpm	3000 rpm
			Force (kN)	Force (kN)	Force (kN)
Axial ¹⁾	Horizontal	Pushing	1.31	1.25	1.10
		Pulling	0.71	0.65	0.50
	Vertical shaft down	Pushing	1.46	1.37	1.18
		Pulling	0.62	0.58	0.45
	Vertical shaft up	Pushing	1.22	1.18	1.05
		Pulling	0.86	0.76	0.58
Radial ²⁾	All	L	0.96	0.88	0.74
		L/2	1.07	1.0	0.85

Table 2 - Maximum permissible thrust - Fr in (kN) 20000 hours

Notes:

¹⁾ Axial maximum load (radial zero).

²⁾ Radial maximum load (axial zero).

1 - All belt loads are considered to act in vertically downward direction.

2 - Overhung loads include belt tension and weight of sheave.

3 - Overhung load limits do not include any effect of unbalanced magnetic pull.

Only remove the corrosion protection grease from the shaft end and flange immediately before the motor installation.

Unless specified otherwise in the purchase order, WEG motors are dynamically balanced with "half key" and without load (uncoupled).

The driving elements, such as pulleys, couplings, etc., must be balanced with "half key" before they are mounted on the shaft of the motors.



ATTENTION!

- The air used for cooling the motor must be at ambient temperature, limited to the temperature indicated on the motor nameplate;
- Take the required measures in order to ensure the degree of protection indicated on the motor nameplate:
- Unused cable inlet holes in the terminal boxes must be properly closed with blanking plugs;
- The cable entries used must be fitted with components, such as, cable glands and conduits;
- Components supplied loose (for example, terminal boxes mounted separately) must be properly closed and sealed;
- Fixing elements mounted in the threaded through holes in the motor enclosure (for example, the flange) must be properly sealed.
- For flying leads motors, do not push the overlength of leads into the motor in order to prevent that they touch the rotor.

Drain hole: WECM / Emerald product can be supplied with drains. Figure 3, Figure 4 and Figure 5 give details about the mounting configuration.

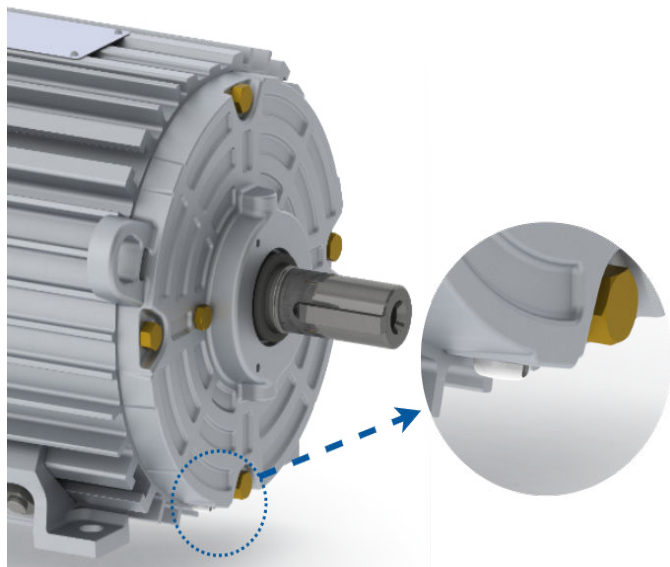

Figure 3 - Drain Position

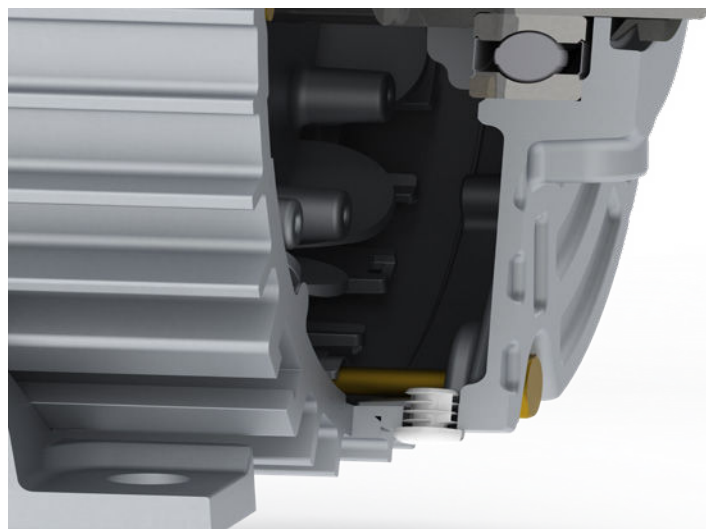

Figure 4 - Drain sectional view



ATTENTION!

■ The motor must always be positioned so the drain hole is at the lowest position;

Slinger: WECM / Emerald product in vertical shaft up mounting should be fitted with water slinger ring to prevent water ingress inside the motor. Consult WEG about this option.



ATTENTION!

Motors installed outdoors or in the vertical position require the use of additional shelter to protect them from water.

Allowed inertias for WECM frames IEC80 and IEC100, according output power and speed:

Frame	Power (kW)	1500 rpm (kgm ²)	1800 rpm (kgm ²)	3000 rpm (kgm ²)
IEC80	0.12	0.16	0.16	0.05
	0.18	0.16	0.16	0.05
	0.25	0.16	0.16	0.05
	0.37	0.27	0.16	0.05
	0.55	0.40	0.27	0.11
	0.75	0.40	0.40	0.11
	1.10	0.62	0.40	0.11
	1.50	0.62	0.62	0.11
IEC100	1.50	0.98	0.98	0.27
	2.20	1.20	1.20	0.47
	3.00	1.63	1.55	0.47
	3.70	1.63	1.63	0.62
	4.00	1.63	1.63	0.62

Table 3 - Table of inertias allowed for three phase line

5.1. POWER CONNECTIONS



DANGER!

Connect the motor properly to the power supply by means of safe and permanent contacts, always considering the data informed on the nameplate, such as rated voltage, wiring diagram, drive inputs, among others.

For power cables, switching and protection devices dimensioning, consider the rated motor current, the service factor, and the cable length, among others. For motors without terminal block, insulate the motor terminal cables by using insulating materials that are compatible with the insulation class informed on the nameplate. The minimum insulation distance between the non-insulated live parts themselves and between live parts and the grounding must meet the applicable standards and regulations for each country.

- Make the power connections following nameplate indication.

Three-phase:

- Power input: L1, L2 and L3 terminals
- Protective earth: PE - green screw

- If used, connect the optional external harmonic filter (passive PFC) in series to the line conductor.

WEG declares that the WECM / Emerald eZA motor line is intended to be used as a part of an end-product and thus is not an independently used machine. All cables of this product need to be internally installed into the enclosure of the final product.



DANGER!

Always connect the equipment to the ground protection (PE).



ATTENTION!

The power supply that feeds the inverter shall have a solid grounded neutral.

5.2. CONTROL CONNECTIONS

- Make the control connections following nameplate indication.

Three-phase:

- DC voltage: VDC and GND terminals
- DC current: ADC and GND terminals
- Frequency duty-cycle / PWM: PWM and GND terminals
- Speed feedback (reference): REF and GND terminals
- 10 VDC source: 10 V and GND terminals
- 24 VDC source: 24 V and GND terminals
- RS485 communication: 485+, 485- and GND terminals
- Alarm relay: NO, NC and COM terminals

5.3. EMC REQUIREMENTS FOR CONFORMING INSTALLATIONS

■ The standard Three-phase WECM / Emerald eZA mounting solution (drive attached to the motor) comply with EN IEC 61800-3 / FCC requirements.

■ For optional decentralized mounting, the product class may change and the product may require the use of external filters. Consult WEG for the solution that better comply with your installation requirements.

■ WECM / Emerald eZA product may require the use of an external filter to comply with **harmonic current emissions requirements (EN61000-3-2)**. Consult WEG about optional external filters.

Power	Conducted	Radiated
2,2 kW – 4 kW	C3	C3

Table 4 - EMC Class - IEC100

To meet the EMC levels in the Table 4, it is necessary to strictly comply with the installation configuration requirements below mentioned:

- Grounding must be carried out on the drive cover in an isolated manner.
- Measurements must be carried out under load, providing the air velocity over the motor as specified in the design.



NOTE!

The end user takes personal responsibility for the EMC compliance of the whole installation.

6. OPERATION INSTRUCTIONS



DANGER!

During operation, do not touch the non-insulated energized parts and never touch or stay too close to rotating parts.

The rated performance values and the operating conditions are specified on the motor nameplate. The voltage and frequency variations of the power supply should never exceed the limits established in the applicable standards.

Occasional different behavior during the normal operation (actuation of thermal protections, noise level, vibration level, temperature and current increase) must always be assessed by qualified personnel. In case of doubt, turn off the motor immediately and contact the nearest WEG service center.

6.1. SELECTING THE ROTATION DIRECTION

- Remove the lid from the back side of the drive cover;
- Use the DIP switch number 1 to select the rotation direction between counter-clockwise (CCW), ON state, or clockwise (CW), OFF state, looking from the motor drive end;
- Reinstall the lid to the back side of the drive cover after the adjust;



NOTE!

If the rotation direction is changed while the product is running, the motor will decelerate, reverse the direction and accelerate to the same speed that was running before.



ATTENTION!

After remove and reinstall, make sure that the lid from the back side of the drive cover is securely closed to guarantee the protection degree.

6.2. HOW TO ADJUST SPEED

The product speed can be changed by local adjust (buttons) or remote adjust (control inputs);

To select between local or remote speed adjust:

- Remove the lid from the back side of the drive cover;
- Use the DIP switch number 2 to select between local (L), ON state, or remote (R), OFF state;
- Reinstall the lid to the back side of the drive cover after the adjust.



ATTENTION!

After remove and reinstall, make sure that the lid from the back side of the drive cover is securely closed to guarantee the protection degree.

Local speed adjusts:

- Remove the lid from the back side of the drive cover;
- Use the two tact buttons located in the opening on the back cover to change speed;
- Keep pressing the button to decelerate or accelerate the motor according identified on the nameplate;
- The motor will turn off when the speed reaches a value lower than the minimum speed of the range;
- The product will not go to speeds higher than the value adjusted to be the maximum speed (see 6.4
- Reinstall the lid to the back side of the drive cover after the adjust.



NOTE!

■ The standard maximum speed value is preset at WEG to be the highest value of the speed range but, can be changed by the user (see item 6.4).

■ The product has speed memory when operating in local speed adjustment. The last speed adjusted will be kept in memory when the input power supply is removed. The motor will accelerate to the memorized speed when the input power supply is reconnected.

■ The local controls inside the opening on the back cover of the product are totally insulated. There is no risk of shock when touch any internal part of this opening, even when the solution is running.



ATTENTION!

After remove and reinstall, make sure that the lid from the back side of the drive cover is securely closed to guarantee the protection degree.

Remote speed adjusts:

The speed can be adjusted by:

- DC voltage: 2 to 10 VDC [tolerance: + 10%].
- DC current: 4 to 20 mA DC [tolerance: + 10%].
- Frequency duty-cycle / PWM: 10 to 95%
 - Voltage: 10 to 24 Vpk [tolerance: -5% / + 10%].
 - Frequency: 80 Hz [tolerance: -2,5% / + 2,5%].
- When available, using the RS485 serial communication (see item 6.7).
- The speed can be adjusted using the external speed controller (see item 6.5).
- The product will turn off if imposed signals lower than 2 V DC, 4 mA DC or 10%.

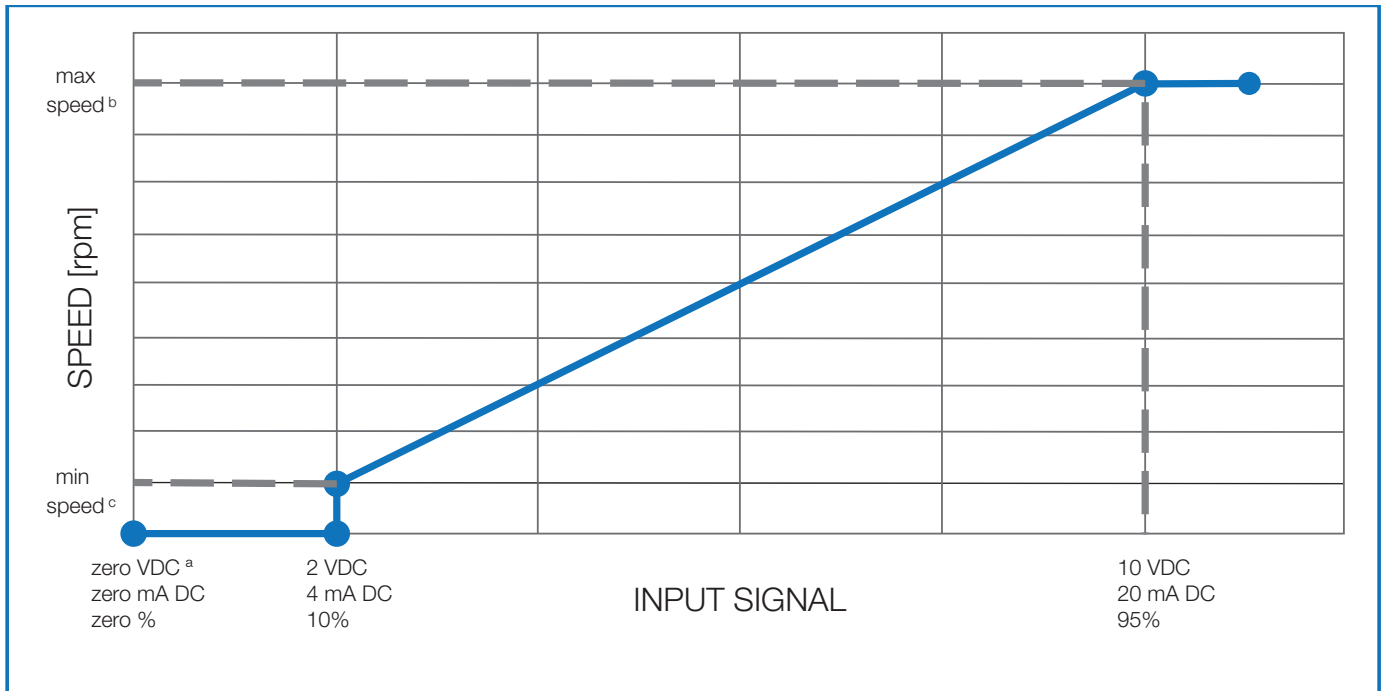

Figure 5 - Control input reference

Signal type	Condition	Resulting speed value
DC voltage ^a	Lower than 2 VDC	Zero (motor is off)
	From 2 to 10 VDC	$((Max^b - Min^c)/8) \times (IS^d - 2) + Min$
DC current	Lower than 4 mA DC	Zero (motor is off)
	From 4 to 20 mA DC	$((Max^b - Min^c)/16) \times (IS^d - 4) + Min$
Frequency	Lower than 10%	Zero (motor is off)
	From 10 to 95%	$((Max^b - Min^c)/85) \times (IS^d - 10) + Min$

Table 5 - Control input reference

Notes:

- a.** The DC voltage signal can be applied by an external power supply or using the built-in 10VDC source and an additional potentiometer (5 kΩ to 10 kΩ).
- b.** Maximum speed adjusted (see item 6.4).
- c.** Minimum speed adjusted (see item 6.4).
- d.** Input signal (V DC, mA DC, %) supplied to the respective remote input.



ATTENTION!

- The built-in power supplies have an output limit of:
 - Three-Phase: 10 mA for the 10 VDC and 350 mA for the 24 VDC.
- The product can be permanently damaged if imposed signals out of the specification.
- Make sure that all unused conductors in control cable are insulated to avoid product malfunction or damage.

6.3. PRODUCT STANDARD FEATURES AND CONTROL REFERENCE

The product has characteristics of reference signals and these can be found in the Table 6 and Figure 7:

Signal	Detail	Signal reference
DC Source	10 VDC	Voltage: 10 VDC, Current: 10 mA max
	24 VDC	Voltage: 24 VDC, Current: 350 mA max
Speed reference	Speed = zero	Frequency [Hz]: zero (4,8 V)
	Speed > zero	Frequency [Hz]: speed (rpm) x 0,6015
Serial communication	RS485	See item 6.7
Alarm relay	Normally Open	Voltage: 250 VAC, 220 VDC – max Current: 2 A max
	Normally Closed	
DIP Switch	1- Rotation Direction	ON: CCW OFF: CW
	2- Control Selection	ON: Local OFF: Remote
	3- RS-485 Termination	ON: 1kΩ resistor OFF: No resistor

Table 6 - Product standard features and control reference



Figure 6 - Frame IEC80.

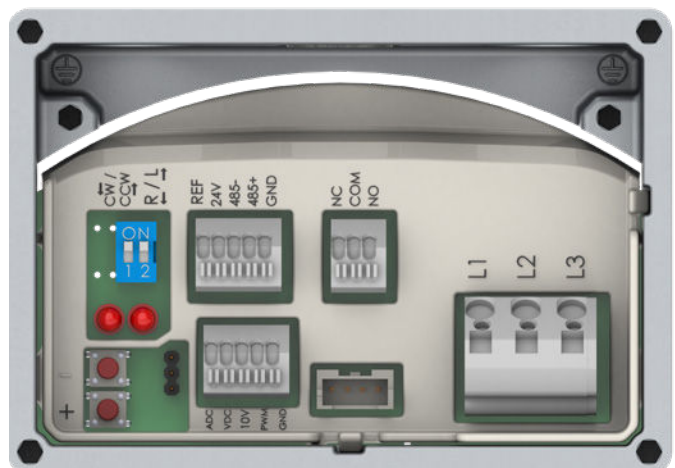

Figure 7 - Frame IEC100.

6.4. HOW TO ADJUST THE MAXIMUM AND MINIMUM SPEED VALUE

6.4.1. MAXIMUM SPEED

The maximum speed value for the remote speed adjust signals can be changed:

- Using the optional WEG EC Motor Speed Controller (see item 6.5).
- Using the product local tact buttons (only up to the maximum speed set by WEG EC Motor Speed Controller).
- Select local speed reference selecting ON in the DIP switch number 2.(see item 6.2).
- Using the tact buttons, adjust the speed to the value desired to be the maximum.
- Select remote speed reference selecting OFF in the DIP switch number 2.
- When available, using the RS485 serial communication (see item 6.7);



NOTE!

- The standard factory preset value for the maximum speed is the rated speed informed in the product nameplate;
- The maximum speed must be equal or lower than the rated speed.
- Consult WEG about different factory maximum speed values.

6.4.2. MINIMUM SPEED

- The standard factory preset value for the minimum speed is 200 rpm for the rated 1500 rpm and 1800 rpm product and 500 rpm for the rated 3000 rpm product.
- Consult WEG about different factory minimum speed values.

6.5. WEG EC MOTOR SPEED CONTROLLER (OPTIONAL)

The running speed and the maximum speed adjust can be done using the external WEG EC Motor Speed Controller. Connect the control cables at the WEG EC Motor speed controller borne. Below picture give the connection sequence.



Figure 8 - Controller sequence connection.



Figure 9 - WEG EC Motor speed controller

Fed the EC motor following the instructions of the item 5.2;

Running speed adjust

- Remove the lid from the back side of the drive cover;
- Connect the control signals (item 5.2) to the external speed controller according to Figure 8;
- Rotate CTR in clockwise direction (CW) to increase the running speed;
- Rotate CTR in counter-clockwise direction (CCW) to reduce the running speed;
- During the adjust, the running speed can be verified in the display;
- Reinstall the lid to the back side of drive cover after the connections are done;

Maximum speed adjust

- Remove the lid from the back side of the drive cover;
- Connect the external controller to the EC motor using the cable supplied with the external controller and the connector inside the EC motor back opening;
- Rotate MAX in clockwise direction (CW) to increase the maximum speed;
- Rotate MAX in counter-clockwise direction (CCW) to reduce the maximum speed;
- During the adjust, the maximum speed can be verified in the display;
- Push the button "Enter" to set the maximum speed;
- Disconnect the cable from the EC motor back opening connector;
- Reinstall the lid to the back side of drive cover after the adjust;
- If the maximum speed set is lower than the running speed, the motor will decelerate until reaching the new maximum speed set.
- If the maximum speed set is lower than the running speed, the motor will decelerate until reaching the new maximum speed set.



ATTENTION!

After remove and reinstall, make sure that the lid from the back side of the drive cover is securely closed to guarantee the protection degree.

6.6. FIRE MODE FUNCTION (OPTIONAL)



DANGER!

Notice that the WECM / Emerald eZA is just one of the components of the ventilation system, and it is configurable for different functions, including the “Fire Mode” function;

Thus, the full operation of the “Fire Mode” function depends on the accuracy of the project and on the joint performance of the components of the system;

Ventilation systems that work on life safety applications must be approved by the Fire Department and/or another competent public authority, according to local regulations;

The non-interruption of the operation of the WECM / Emerald eZA, when configured for operation in the “Fire Mode” function, is critical and must be taken into account in the preparation of safety plans in the environments in which they are installed, since damages may occur to the WECM / Emerald eZA itself and to other components of the ventilation system, to the environment in which it is installed and to people with risk of death;

The operation in the “Fire Mode” function may, under certain circumstances, result in fire, since the protection devices will be disabled;

Only personnel from engineering and safety must consider the configuration of the equipment for the “Fire Mode” function;

WEG strongly recommends to follow the cares and procedures above before using the WECM / Emerald eZA in the “Fire Mode” function, and it will not be liable to the final user or third parties for any losses or damages direct or indirectly incurred due to the programming and operation of the WECM / Emerald eZA in “Fire Mode” regime, considering the critical and special use of this function.



NOTE!

WECM are not ‘smoke extraction’ motors (as defined in EN 12101-3) and may not under any circumstances be installed inside the high temperature airstream.



NOTE!

When the user activates the “Fire Mode” function, he/she acknowledges that the protection functions of the WECM / Emerald eZA are disabled, which may result in damages to the WECM / Emerald eZA itself, to the components connected to it, to the environment in which it is installed and to people present in such environment; therefore, the user takes full responsibility for the risks arising from such operating condition. Operation with the “Fire Mode” function programmed voids the warranty of the product. The operation in this condition is internally registered by the WECM / Emerald eZA and must be validated by a duly qualified professional of engineering and occupational safety, since such procedure significantly increases the operating risk.

The “Fire Mode” function is intended to make the WECM / Emerald eZA continue work under adverse conditions, inhibiting most faults generated by the electronic in order to protect itself or protect the motor.

The “Fire Mode” is selected by applying 10VDC to the frequency input. The built-in 10 VDC source can be used. When selected, the motor will speed up to the maximum speed set and will disable all motor software protections.

The only possible way to turn off the “Fire Mode” operation function is to de-energize the complete solution and energize it back again.

6.7. SERIAL COMMUNICATION

6.7.1. Hardware preparation:

USB to 485 Converter

Setting:

- Step 1: Install the driver of USB to 485 Converter on PC.
- Step 2: Connect converter with ECM Motor:
 - Connect A pin of USB to 485 Converter with 485+ signal of ECM Motor.
 - Connect B pin of USB to 485 Converter with 485- signal of ECM Motor.
 - Connect GND of USB to 485 Converter with GND signal of ECM Motor.

6.7.2. Software preparation:

- Modbus RTU communication tool (provided by EMC Group).
- Modbus RTU MulticomV3.0 Parameter Setting:

1. Communication parameter setting:

- Step 1: Connect USB to 485 Converter with PC USB port.
- Step 2: Select interface: Serial.
- Step 3: Communication common port configure (refer to Figure 10).
- Step 4: After the above operations are completed, please select “connect” (refer to Figure 11).

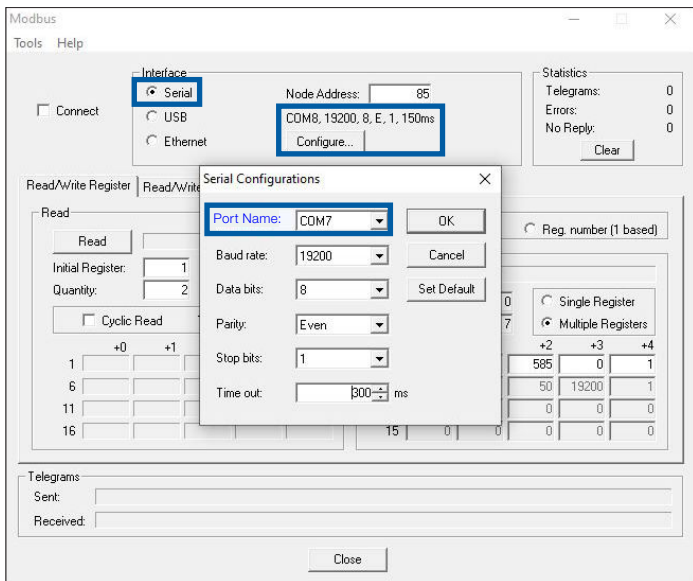

Figure 10 - Modbus parameter setting

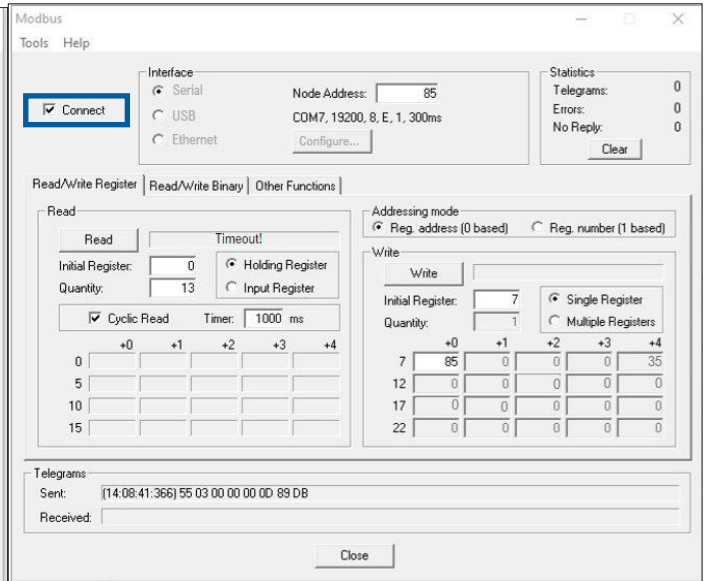

Figure 11 - Modbus connecting

After completing the above preparations, please turn on the power of the ECM Motor.
Confirm the ECM Motor Modbus slaver address: The default address is 0x55(85).

2. Operation instruction:

- Step 1: Input the default address 85 in the Node box.
- Step 2: Select “Read/Write register”, input register the initial address and quantity, and click read. Check whether the read function can be executed successfully. If communicating successfully, it shows like Figure 10. If communicating fails, it shows like Figure 13, and it is required to get the right address of this ECM Motor (Refer to Step 3).

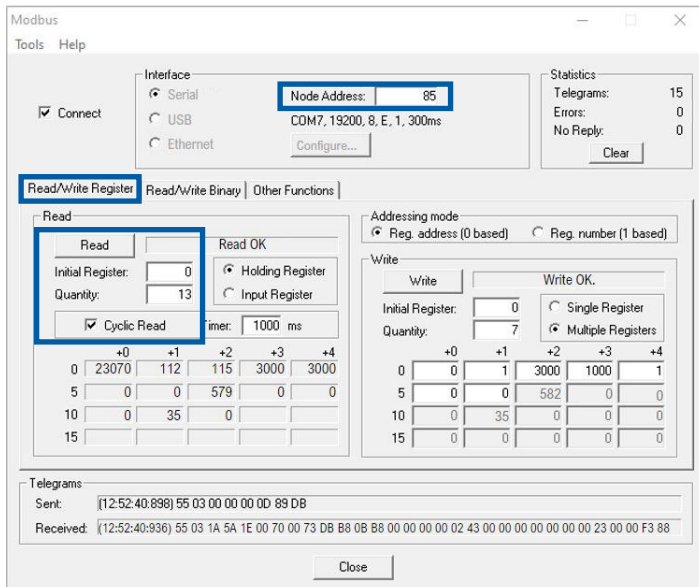

Figure 12 - Modbus communication succeed

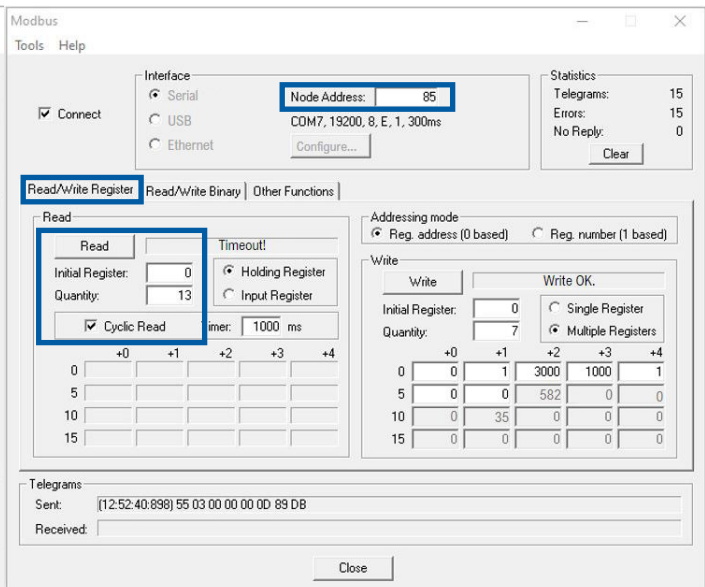

Figure 13 - Modbus communication fail

■ **Step 3:** Obtain the current Modbus address, please refer Figure 14. Input the broadcast address 0, Select “Other function”, read device ID (01-Basic Objects) or directly send “00 2B 0E 01 00 4D B7”. When the ECM Motor received the request, the LED1 on the PCBA will flash address count.

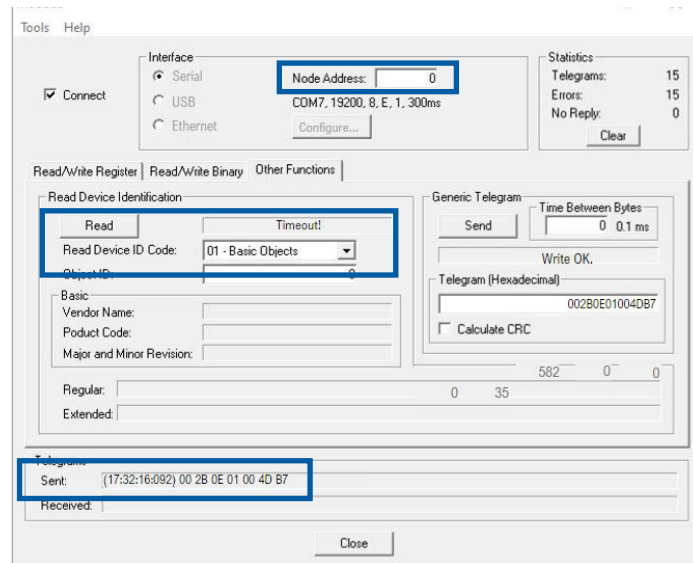

Figure 14 - Modbus communication fail

3. Set Modbus address (The master can only set slaver address one by one):

- Step 1: Establish the Modbus RTU communication, the default address is 85 for the first-time connection.
- Step 2: Input the new address (for example 10) in register W(06) 0x0134, and click write (Figure 15).
- Step 3: After write-in the new address, the old one is disable. Input the new address in Node, and check communication (Figure 16).

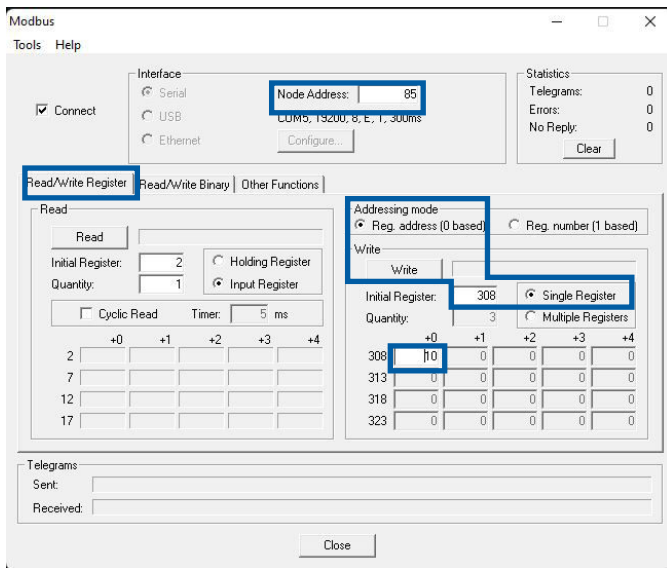

Figure 15 - Write address

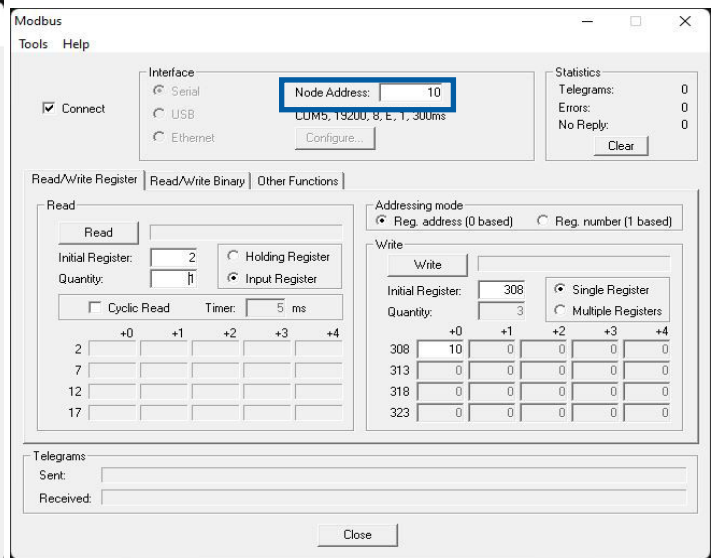

Figure 16 - Check communication

Note: If the MODBUS address is not the default address and communication can be established with the original address, the new address can be set in the same way as above.

4. Set Modbus address (The master can only set slaver address one by one now):

After setting the new address successfully, please refer to Modbus command and address section below for more Read / Write details.

5. Default serial configuration:

If the Modbus serial configuration of Inverter has never been changed, then the default setting will be always available.

Baud rate: 19200 bits/s

Start bit: 1 bit

Data bits: 8 bits

Parity: Even

Stop: 1 bit

6. Reset Modbus control and serial configuration to factory default:

- Remove the lid from the back side of the drive cover.
- Press and hold local tact buttons SW1 and SW2 both for 5 Sec.
- After 5 Sec, LED #2 starts fast blinking at 5 Hz to confirm even handled.

Factory default reset value are as follow:

Modbus control enable: 0

MODBUS address: 0x55(85)

Baud rate: 19200 bits/s

Data bits: 8 bits

Parity: Even

Stop: 1 bit

- Reinstall the lid to the back side of drive cover.

7. Modbus serial configuration selection

In order to make the Modbus control available for different serial configuration. The serial parameters of inverter can be changed by Modbus command.

The register W(06) 0x0136 is used to set the baud rate, writing the corresponding baud rate in the register W(06) 0x0136 according to Table 7.

The register W(06) 0x0137 is used to set the other parameters of serial (Parity and Stop bit), writing the corresponding value in the register W(06) 0x0137 according to Table 8.

Baud rate (bits/s)	Correspond Value of Register 0x0008
2400	2400
4800	4800
9600	9600
19200	19200
38400	38400
57600	57600

Table 7 - Baud Rate setting

Parity /Stop bit	Correspond Value of Register 0x0009
No parity, 1 stop bit	0x0000
Even parity, 1 stop bit	0x0001
Odd parity, 1 stop bit	0x0002
No parity, 2 stop bits	0x0003
Even parity, 2 stop bits	0x0004
Odd parity, 2 stop bits	0x0005

Table 8 - Parity and Stop bit setting

8. Setting serial configuration

- Step 1: Firstly establish Modbus communication between slave inverter and master:
- Step 2: Writing Register W(06) 0x0136 and W(06) 0x0137 according to Table 7 and Table 8, other values are invalid;
- Step 3: Writing "1" into Register W(05) 0x0192 to enable new serial configuration as Step 2;
- Step 4: After Step 3, Master with original configuration will losses communication with slaver, then master needs to change to new serial configuration, rebuild the communication with slaver.

9. Modbus command and address

01 Request Frame							
Slaver Address (1 byte)	0x01 (function code)	Register Address (2 bytes)	0x0001 (2 bytes)	CRC (2 bytes)			

01 Answer				
Slaver Address (1 byte)	0x01 (function code)	Register Number (1 byte)	Data (1 byte)	CRC (2 bytes)

02 Request Frame				
Slaver Address (1 byte)	0x02 (function code)	Register Address (2 bytes)	0x0001 (2 bytes)	CRC (2 bytes)

02 Answer				
Slaver Address (1 byte)	0x02 (function code)	Register Number (1 byte)	Data (1 byte)	CRC (2 bytes)

03 Read Frame				
Slaver Address (1 byte)	0x03 (function code)	Register Start Address (2 bytes)	Register Numbers N (2 bytes)	CRC (2 bytes)

03 Answer						
Slaver Address (1 byte)	0x01 (function code)	Register Number N*2 (1 byte)	Request Data 1 (2 bytes) (datas)	Request Data N (2 bytes)	CRC (2 bytes)

04 Request Frame				
Slaver Address (1 byte)	0x04 (function code)	Register Start Address (2 bytes)	Register Numbers N (2 bytes)	CRC (2 bytes)

04 Answer						
Slaver Address (1 byte)	0x04 (function code)	Register Number N*2 (1 byte)	Request Data 1 (2 bytes) (datas)	Request Data N (2 bytes)	CRC (2 bytes)

05 Write Frame				
Slaver Address (1 byte)	0x05 (function code)	Register Start Address (2 bytes)	Write Content (2 bytes)	CRC (2 bytes)

05 Answer				
Slaver Address (1 byte)	0x05 (function code)	Register Start Address (2 byte)	Write Content (2 byte)	CRC (2 bytes)

06 Write Frame				
Slaver Address (1 byte)	0x06 (function code)	Register Address (2 bytes)	Write content (2 bytes)	CRC (2 bytes)

06 Answer				
Slaver Address (1 byte)	0x06 (function code)	Register Address (2 bytes)	Write content (2 bytes)	CRC (2 bytes)

16 Write Frame							
Slaver Address (1 byte)	0x10 (function code)	Register start Address (2 bytes)	Registers number N (2 bytes)	Registers byte number N*2 (1 byte)	Write content 1 (2 bytes)	Write content N (2 bytes)	CRC (2 bytes)

16 Answer				
Slaver Address (1 byte)	0x10 (function code)	Register start Address (2 bytes)	Register number N (2 bytes)	CRC (2 bytes)

Figure 17 - Modbus command and address

Address table:

For software version below V1.03 use table 9; For software version V1.03 use table 10. All other examples in this manual are based on the function codes and register address from software version V1.03. Contact WEG if there is any questions regarding software version.

Read	Function	Read (R) or Write (W) Address	Values (D = Default value)
R(01)	Local/Remote Mode	R: 0000	0: Local; 1: Remote.
R(01)	Relay State	R: 0001	0: open 1: close
R(01)	Read Fire mode flag	R: 0002	0: out fire mode; 1: in fire mode
R(01)	Read AC lose flag	R: 0003	0: False 1: True
R(01)	Read direction	R: 0004	0: CW 1: CCW
R(01)	Read Run/Stop	R: 0005	0: Stop; 1: Run.
R(03)	Read motor number	R: 0000	
R(03)	Read Firmware version (Motor)	R: 0001	
R(03)	Read Software version (Communication)	R: 0002	
R(03)	FCT Max Speed	R: 0003	
R(03)	Current Max Speed	R: 0004	
R(03)	Read motor Target speed	R: 0005	
R(03)	Read motor actual speed	R: 0006	
R(03)	Read LINK DC motor voltage	R: 0007	Volts
R(03)	Read LINK DC motor current	R: 0008	10mA (value in this register times 10mA)
R(03)	Read Fault code	R: 000B	
R(03)	Read Fault code	R: 000C	address:000C Refer to Table 4– Fault Code Table
R(03)	Read multi register	0x01 + 0x03 +start address+ register number N + CRC	0x01 + 0x03 +start address+ register number N + CRC
W(06)	Modbus control enable	W: 0000	0: disable (D) 1: enable
W(06)	Run/Stop	W: 0001	0: Stop (D) 1: Run
W(06)	Write Max speed	W: 0002	
W(06)	Write Target speed	W: 0003	0 – Max. Speed 0 (D)
W(06)	Write Target direction	W: 0004	0: CW (D) 1: CCW
W(06)	Turn on/off Fire mode	W: 0005	0: Fire mode disable (D) 1: Fire mode active
W(06)	Write Local/remote	W: 0006	0: Local Mode 1: Remote Mode (D)
W(06)	Write Modbus address	W: 0007	Valid range 0-99 85 (D) Note: Max. number of motors connected should not be bigger than 32
W(16)	Write Multi register	Write Register address:0000	
W(06)	Slaver Baud-Rate	W: 0008	See Table 2– Baud Rate Setting
W(06)	Slaver Parity and stop bit	W: 0009	See Table 3– Parity and Stop bit setting
W(06)	Enable serial parameters	W: 000A	0: No action 1: Enable configure Refer to 4.3.4
W(06)	Communication time-out period (Seconds)	W: 000B	Value in seconds (Default:0 - disabled)
W(06)	Communication time-out period (ms)	W: 000C	Value in milliseconds (Default:0 – Disabled)
W(06)	Safety Speed	W: 000D	Default 200 RPM
W(06)	Deceleration rate*1	W: 000E	0-300 RPM/S 0 (D)
W(06)	Acceleration rate*1	W: 000F	0-500 RPM/S 0 (D)
W(06)	Blanking time*1	W: 0010	0-65534 Seconds 0 (D)

Table 9 - Register map for software version below V1.03

Function Code		Register Address		Description	Values (D): Default value
Read	Write	Hex	Multicom V3		
R (04)	-	0x0002	0002	Read motor actual speed	
R (04)	-	0x0003	0003	Read LINK DC motor current	
R (04)	-	0x0004	0004	Read LINK DC bus voltage	
R (04)	-	0x0005	0005	Read frequency (motor)	
R (04)	-	0x0007	0007	Read output voltage (motor)	Calculation based on approximations from ventilation application -15% tolerance. For other applications is required to consult WEG.
R (04)	-	0x0008	0008	Read analog input (VSP)	mV resolution
R (04)	-	0x0009	0009	Read analog input (ISP)	mA resolution
R (04)	-	0x000A	0010	Read analog input (PWM)	1% resolution
R (04)	-	0x0017	0023	Read software version of Mid-controller	
R (04)	-	0x0018	0024	Read firmware version of motor driver MCU	
R (04)	-	0x0019	0025	Read FCT Max Speed	
R (04)	-	0x001A	0026	Read motor number	
R (04)	-	0x001E	0030	Read IPM Temperature	°C
R (04)	-	0x0032	0050	Read Error code	
R (01)	W (05)	0x00DC	0220	Local/Remote mode	0: Local mode 1: Remote mode
R (01)	W (05)	0x00DD	0221	Modbus control enable	0: Enable modbus control enable 1: Disable modbus control enable
R (01)	W (05)	0x00DF	0223	Target direction	0: CW 1: CCW
R (03)	W (06)	0x0134	0308	Modbus address	Valid range 0-99 85 (D)
R (03)	W (06)	0x0136	0310	Serial Configure: Baud Rate	See Table 2– Baud Rate Setting
R (03)	W (06)	0x0137	0311	Serial Configure: Parity & Stop	See Table 3– Parity and Stop bit setting
R (02)	-	0x015E	0350	Relay state	0: open 1: close
R (02)	-	0x015F	0351	Motor status: running or stopped	0: Motor stopped 1: Motor running
R (03)	W (06)	0x0190	0400	Safety Speed	
R (01)	W (05)	0x0191	0401	Fire Mode	0: out fire mode 1: in fire mode
R (01)	W (05)	0x0192	0402	New Serial Configure Enable	0: No action 1: Enable configure Refer to 4.3.4
R (03)	W (06)	0x0193	0403	Communication time-out period (Seconds)	Value in seconds (Default:0 - disabled)
R (03)	W (06)	0x0194	0404	Communication time-out period (ms)	Value in milliseconds (Default:0 – Disabled)
R (03)	W (06)	0x01C2	0450	Max speed	
R (03)	W (06)	0x01C3	0451	Target speed	
R (03)	W (06)	0x01C4	0452	Modbus control run/stop	0: Stop 1: Run

Table 10 - Register map for software version V1.03

11. Fault error code

Error Code	Fault Description
0x0001	DCBUS LOW
0x0002	DCBUS HIGH
0x0003	OVER CURRENT (HARDWARE PROTECTION)
0x0004	TEMPERATURE CRITICALLY HIGH
0x0005	LOCKED ROTOR
0x0006	COMMUNICATION TIMEOUT
0x0007	OVER LOAD
0x0008	OVER SPEED

7. PRODUCT PROTECTIONS AND FAULT DIAGNOSIS

WECM / Emerald eZA products have the following electronic protections:

- Input under voltage protection.
- Input over voltage protection.
- Input over load protection.
- Locked rotor protection.
- Over temperature protection.
- Output overcurrent / short-circuit protection.

WECM / Emerald eZA products have LED's in the opening on the back side to indicate the solution status and to help in the fault diagnosis:

Input Power supply	Motor status	LED #1	LED #2
Off	Stopped	Off	Off
On	Stopped	Off	Blinking (1 Hz)
On	Running	On	Blinking (1 Hz)
On	Fault	Blinking according fault (check Table 9)	Blinking (1 Hz)



DANGER!

- The LED in OFF condition doesn't mean that there is no power supply to the drive;
- Make sure that the input power supply is disconnected before do any maintenance in the product.
- If the Fire Mode function is active, the failures will be detected, but ignored by WECM / Emerald eZA, i.e., will not block the IGBTs. If the motor was spinning, will continue spinning. For more information see item 6.5

The LED #1 will blink in case of any fault. Table 10 indicates the blinking behavior according the fault type:

Blinking periods	Fault	ON time (s)	Off time (s)	Wait / interval time (off) (s)
2	Under voltage	0,1	0,1	-
3	Over current (shor-circuit)	0,25	0,25	2
5	Over temperature			
6	Over voltage			
7	Over load			
8	Over speed			
9	Communication timeout			
10	Watchdog fault			
11	Locked rotor			

Table 11 - The blinking behavior according to fault type

- Communication timeout fault: failure in the drive to motor communication;
- Watchdog timeout fault: failure in the drive processor / software.

7.1. INFORMATION FOR CONTACTING TECHNICAL SUPPORT

For technical support and servicing, it is important to have the following information in hands:

Motor model, Batch number, and manufacturing date available in the motor nameplate (refer to item 4).

- Installed software version available in the drive label (refer to item 4).

8. MAINTENANCE



DANGER!

- Before any service is performed, ensure that motor is at standstill, disconnected from the power supply and protected against accidental energization. Even when the motor is stopped, dangerous voltages may be present in space heater terminals;
- For motors with permanent magnet rotor (WECM and Emerald eZA), the motor assembly and disassembly require the use of proper devices due to the attracting or repelling forces that occur between metallic parts. This work must only be performed by a WEG Authorized service center specifically trained for such an operation. People with pacemakers cannot handle these motors. The permanent magnets can also cause disturbances or damages to other electric equipment and components during maintenance.



ATTENTION!

- Motor disassembly during the warranty period must be performed by a WEG authorized service center only;
- Regularly inspect the operation of the motor, according to its application, and ensure a free air flow. Inspect the seals, the fastening bolts, the bearings, the vibration and noise levels, the drain operation, etc. The lubrication interval is specified on the motor nameplate.

9. ENVIRONMENTAL INFORMATION

For information regarding disposal at end of life cycle refer to the manual "[Disposal and Environmental Information](#)" available in the website www.weg.net or contact WEG.

10. ADDITIONAL INFORMATION

For further information about shipment, storage, handling, installation, operation and maintenance of electric motors, access the website www.weg.net.

For special applications and operating conditions refer to the manual 50033244 available in the website or contact WEG. When contacting WEG, please, have the full description of the motor at hand, as well as the Motor model, Batch Number and manufacturing date, indicated on the motor nameplate.

10.1. WARRANTY TERM

WEG Equipamentos Elétricos S/A, Motors Unit ("WEG"), offers warranty against defects in workmanship and materials for its products for a period of 18 months from the invoice date issued by the factory or distributor/dealer, limited to 24 months from the date of manufacture.

The paragraphs above contain the legal warranty periods.

If a warranty period is defined in a different way in the commercial/technical proposal of a particular sale, that will supersede the time limits set out above.

The warranty periods above are independent of the product installation date and the startup.

If any defect or abnormal occurrence is detected during machine operation, the customer must immediately notify WEG in writing about the occurred defect and make the product available for WEG or its Authorized Service Center for the period required to identify the cause of the defect, check the warranty coverage, and perform the proper repairs.

In order for the warranty to be valid, the customer must be sure to follow the requirements of WEG's technical documents, especially those set out in the product Installation, Operation and Maintenance Manual, as well as the applicable standards and regulations in force in each country.

Defects arising from the inappropriate or negligent use, operation, and/or installation of the equipment, non-execution of regular preventive maintenance, as well as defects resulting from external factors or equipment and components not supplied by WEG, will not be covered by the warranty.

The warranty will not apply if the customer at its own discretion makes repairs and/or modifications to the equipment without prior written consent from WEG.

The warranty will not cover equipment, components, parts and materials whose lifetime is usually shorter than the warranty period. It will not cover defects and/or problems resulting from force majeure or other causes not imputable to WEG, such as, but not limited to: incorrect or incomplete specifications or data supplied by the customer; transportation, storage, handling, installation, operation and maintenance not complying with the provided instructions; accidents; defects in the construction works; use in applications and/or environments for which the machine was not designed; equipment and/or components not included in the scope of WEG supply. The warranty does not include disassembly services at the buyer's premises, product transportation costs and travel, lodging and meal expenses for the technical staff of the Service Centers, when requested by the customer.

The services under warranty will be provided exclusively at WEG authorized Service Centers or at one of its manufacturing plants. Under no circumstances will the warranty services extend the equipment warranty period.

WEG's Civil Liability is limited to the supplied product; WEG will not be liable for indirect or consequential damages, such as losses of profit and revenue losses and alike which may arise from the contract signed between the parties.

11. TECHNICAL SPECIFICATIONS

11.1. POWER SUPPLY

- Rated voltage: according product nameplate;
- Voltage tolerance: -10% to +10%;
- Frequency: 50/60 Hz (48Hz to 62Hz);
- Phase imbalance: $\leq 3\%$ of the rated phase-to-phase input voltage;
- Minimum interval between consecutive starts: 5 minutes.
- Maximum 1 connection from power supply cycle per 5 minutes

11.2. STANDARDS AND DIRECTIVES

- EN 60034 - 1: 2010: Rotating electrical machines - Part 1: Rating and performance
- EN 60034 - 2 - 1: 2014: Rotating electrical machines - Part 2 - 1: Standard methods for determining losses and efficiency from tests (excluding machines for traction vehicles)
- EN 60034 - 5: 2020: Rotating electrical machines - Part 5: Degrees of protection provided by the integral design of rotating electrical machines (IP code) – Classification
- EN 60034 - 6: 1993: Rotating electrical machines - Part 6: Methods of cooling (IC code)
- EN 60034 - 7: 2020: Rotating electrical machines - Part 7: Classification of types of constructions, mounting arrangements and terminal box position (IM code)
- EN 60034 - 8: 2007 / A1: 2014: Rotating electrical machines - Part 8: Terminal markings and direction of rotation
- EN 60034 - 9: 2005 / A1:2007: Rotating electrical machines - Part 9: Noise limits
- EN 60034 - 14: 2018: Rotating electrical machines - Part 14: Mechanical vibration of certain machines with shaft heights 56 mm and higher - measurement, evaluation and limits of vibration
- CLC/TS 60034 - 25: 2008: Rotating electrical machines – Part 25: Guidance for the design and performance of a.c. motors specifically designed for converter supply
- CLC IEC/TS 60034 - 30 - 2: 2021: Rotating electrical machines - Part 30 - 2: Efficiency classes of variable speed AC motors (IE-code)
- EN IEC 63000: 2018: Technical documentation for the assessment of electrical and electronic products with respect to the restriction of hazardous substances (IEC 63000:2016)
- EN IEC 61800 - 3: 2018: Adjustable speed electrical power drive systems - Part 3: EMC requirements and specific test methods
- EN 60204-1: 2018: Safety of machinery - electrical equipment of machines - Part 1: General requirements
- IEC 61800-5-1: 2007 / A1: 2017 / A1: 2021: Adjustable speed electrical power drive systems - Part 5 - 1: Safety requirements - Electrical, thermal and energy (single-phase products)

EU DECLARATION OF CONFORMITY

Manufacturers:

Changzhou Yatong Jiewei Electromotor Co.,LTD
No.118, Dongdu West Road, Luoyang Town, Wujin,
Changzhou, Jiangsu, China.
www.weg.net/cn

WEG (Chang Zhou) Automation Equipment Co.,Ltd
No.2226, South Second Ring East Road, Jintan District,
Changzhou City, Jiangsu Province, China
www.weg.net/cn

WEGeuro – Industria Electrica S.A.
Headquarters:
Rua Eng Frederico Ulrich, Apartado 6074
4476-908 – Maia – Porto – Portugal
www.weg.net/pt
Contact person: Luís Filipe Oliveira Silva Castro Araújo
Authorised Representative in the European Union
(Single Contact Point)

The manufacturer declares under sole responsibility that:

WEG electric motors and components used for following motor lines:

**WECM – WEG Electronically Commutated Motor
BLDC – Permanent Magnetic Synchronous Motor (AI)**

when installed, maintained and used in applications for which they were designed, and in compliance with the relevant installation standards and manufacturer's instructions, comply with the provisions of ———the following relevant European Union harmonization legislation, wherever applicable:

**Low Voltage Directive 2014/35/EU
EMC Directive 2014/30/EU
RoHS Directive 2011/65/EU and its amendments (Including Directive 2015/863/EU)**

The fulfilment of the safety objectives of the relevant European Union harmonisation legislation has been demonstrated by compliance with the following standards, wherever applicable:

EN 60034-2-1: 2014 / EN 60034-1: 2010 / EN IEC 60034-5: 2020 / EN IEC 60034-6: 1993 / IEC 60034-7: 2020 / EN 60034-8: 2007/A1: 2014 / EN 60034-9: 2005/A1: 2007 / EN IEC 60034-14: 2018 / CLC/TS 60034-25: 2008 / CLC IEC/TS 60034-30-2: 2021 / EN IEC 63000: 2018 / EN IEC 61800-3: 2018 / EN 60204-1: 2018 / WECM and BLDC: EN 61800-5-1: 2007/A1:2017/A11:2021



Signed for and on behalf of the manufacturer
Rogerio Aguiar Rodrigues
Managing Director

Changzhou, May 10, 2022

UK CA Declaration of Conformity Manufacturers:

Changzhou Yatong Jiewei Electromotor Co.,LTD
No.118, Dongdu West Road, Luoyang Town, Wujin,
Changzhou, Jiangsu, China.
www.weg.net/cn

WEG (Chang Zhou) Automation Equipment Co.,Ltd
No.2226, South Second Ring East Road, Jintan District,
Changzhou City, Jiangsu Province, China
www.weg.net/cn

WEGeuro – Industria Electrica S.A.

WEG electric motors and components used for following motor lines:

WECM – WEG Electronically Commutated Motor BLDC – Permanent Magnetic Synchronous Motor (AI)

when installed, maintained and used in applications for which they were designed, and in compliance with the relevant installation standards and manufacturer's instructions, comply with the provisions of the following relevant United Kingdom statutory requirements, wherever applicable:

The Restriction of the Use of Certain Hazardous Substances in Electrical and Electronic Equipment Regulations 2012 – S.I. 2012/3032 Electrical Equipment (Safety) Regulations 2016 – S.I. 2016/1101 Electromagnetic Compatibility Regulations 2016 – S.I. 2016/1091

The fulfilment of the safety objectives of the relevant United Kingdom statutory requirements has been demonstrated by compliance with the following designated standards, wherever applicable:

**EN 60034-2-1: 2014 / EN 60034-1: 2010 / EN IEC 60034-5: 2020 / EN IEC 60034-6: 1993 / IEC 60034-7: 2020 / EN
60034-8: 2007/A1: 2014 / EN 60034-9: 2005/A1: 2007 / EN IEC 60034-14: 2018 / CLC/TS 60034-25: 2008 / CLC
IEC/TS 60034-30-2: 2021 / EN IEC 63000: 2018 / EN IEC 61800-3: 2018 / EN 60204-1: 2018 / WECM and BLDC:
EN 61800-5-1: 2007/A1:2017/A11:2021**



Signed for and on behalf of the manufacturer
Rogerio Aguiar Rodrigues
Managing Director

Changzhou, May 10, 2022



B&P ELEKTROMOTOREN BV

Expeditiweg 21
6657 KM Boven-Leeuwen

info@bnpelektromotoren.nl

+31 (0)344 616 267

BTW nr. NL819113918B01

KvK nr. 30237800

ING Bank NL60 INGB 0675 304 792



www.bnpelektromotoren.nl