



B&P Elektromotoren

W51 HD

Three-phase Electric Motor

Technical Catalogue
European Market

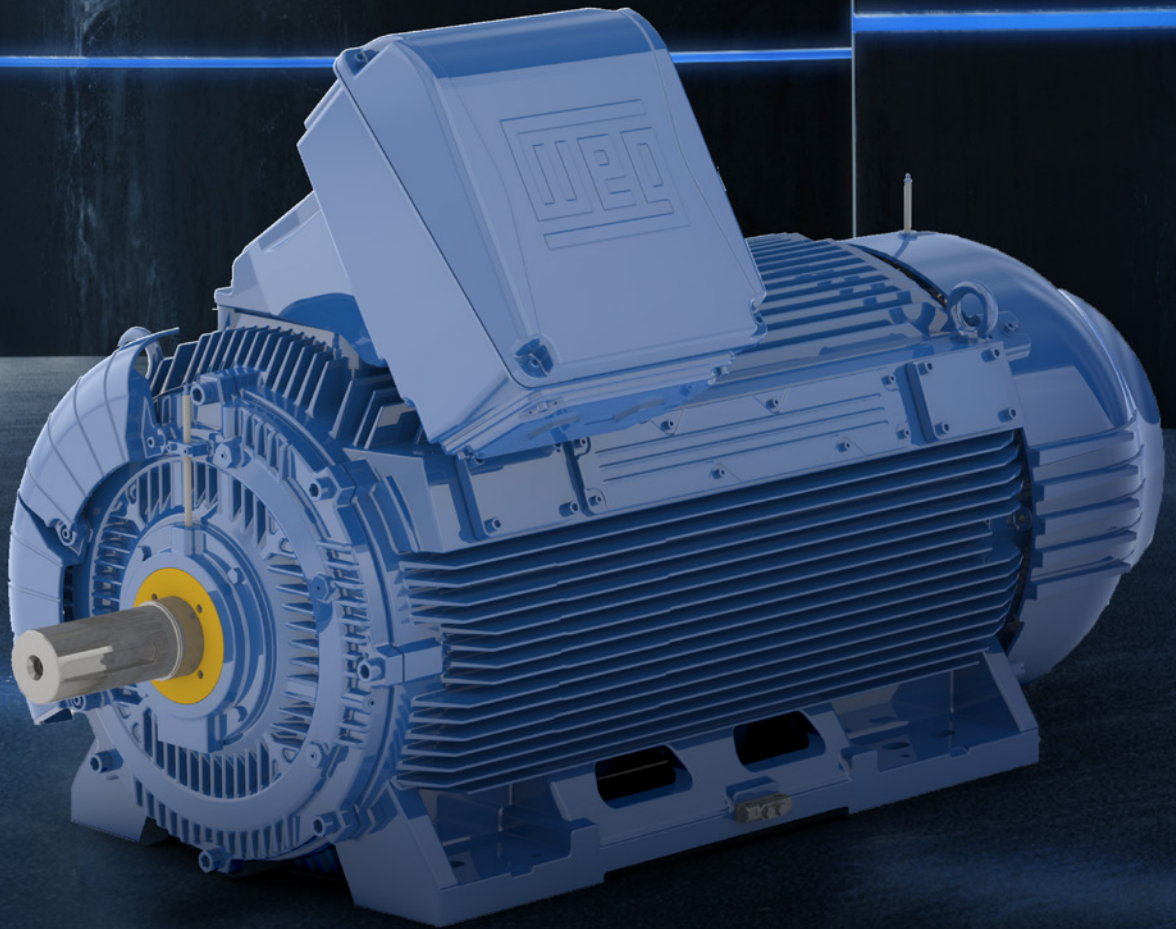

Motors | Automation | Energy | Transmission & Distribution | Coatings

Index

1. Available Versions	6
2. Standards	6
3. Environment	6
4. Construction Details	6
4.1 Frame	6
4.2 Eyebolts	7
4.3 Grounding Terminals	8
4.4 Grounding Brush	8
4.5 Terminal Box	8
4.6 Stator Winding	9
4.7 Endshields	10
4.8 Drains	10
4.9 Fan Cover	10
4.10 Air Baffle	10
4.11 Nameplate	11
5. Ventilation System/Noise Level/Vibration	12
5.1 Ventilation System	12
5.2 Noise Level	13
5.3 Vibration	13
6. Shaft/Bearings/Stresses	14
6.1 Shaft	14
6.2 Bearings	14
6.3 Maximum Radial and Axial Loads	16
7. Mounting Forms	18
8. Degree of protection/Bearing sealing/Painting	19
8.1 Degree of Protection	19
8.2 Bearing Sealing	19
8.3 Painting	19
9. Voltage/Frequency	19
10. Operation Characteristics	20
10.1 Thermal Protection	20
10.2 Operation with Frequency Inverter	20
11. Installation Characteristics	21
11.1 Strength and Mass of the Motor Mechanical Support System (MSS)	21
11.2 Dimensional Control	21
12. Special Accessories	22
12.1 Encoder	22
12.2 Protection Against Voltage Surge	22
12.3 Leveling Screw	22
12.4 Non-Reverse Ratchet	22
12.5 Thermometer	23
12.6 Interchangeability Solutions	23
12.7 Automatic Lubricator	23
13. Construction Features	24
14. Optional Features	25
15. Electrical Data	28
15.1 W51 HD Safe and Hazardous Area - Low Voltage	28
15.2 W51 HD Safe and Hazardous Area - High Voltage 1,2 kV to 5,0 kV	31
15.3 W51 HD Safe and Hazardous Area - High Voltage 5,1 kV to 6,6 kV	34
16. Mechanical Data	36
16.1 Frames 315G/F to 450H/G	36
16.2 "FF" Flange	37
16.3 External Motor Dimensions with Steel Plate Terminal Box	37
16.4 External Motor Dimensions with Sleeve Bearing	37
16.5 External Motor Dimensions with Forced Ventilation	38
16.6 Drip Cover Height	38
17. Terminal Boxes	39
17.1 Cast Iron Terminal Boxes	39
17.2 Steel Plate Terminal Boxes	42
18. Packaging	49
19. Spare Parts	50

1. Available Versions

The W51 HD motors are three-phase asynchronous motors with a squirrel-cage rotor, fully enclosed. This line is available in IEC 315 to 450 and equivalent NEMA frames, in low and medium voltage (up to 6.6 kV). Motors above 6.6 kV up to 11 kV can also be supplied upon request.

2. Standards

W51 HD motors are designed in accordance with IEC EN 60034-1 standard. They also meet the requirements and recommendations of other standards, as indicated in Table 1.

Standard	Title
IEC EN 60034-1	Rotating electrical machines Part 1: Rating and performance
IEC 60034-2-1	Rotating electrical machines Part 2-1: Standard methods for determining losses and efficiency from tests (excluding machines for traction vehicles)
IEC 60072-1	Dimensions and output series for rotating electrical machines. Part 1: Frame numbers 56 to 400 and flange numbers 55 to 1080
IEC 60072-2	Dimensions and output series for rotating electrical machines. Part 2: Frame numbers 355 to 1000 and flange numbers 1180 to 2360
IEC 60034-8	Rotating electrical machines Part 8: Terminal markings and direction of rotation
IEC 60034-7	Rotating electrical machines Part 7: Classification of types of construction, mounting arrangements and terminal box position (IM Code)
IEC 60034-11	Rotating electrical machines - Part 11: Thermal protection
IEC 60034-6	Rotating electrical machines Part 6: Methods of cooling (IC Code)
IEC 60034-5	Rotating electrical machines Part 5: Degrees of protection provided by the integral design of rotating electrical machines (IP code) - Classification
IEC 60034-14	Rotating electrical machines - Part 14: Mechanical vibration of certain machines with shaft heights 56 mm and higher - Measurement, evaluation and limits of vibration severity
IEC 60034-9	Rotating electrical machines - Part 9: Noise limits
IEC 60034-12	Rotating electrical machines - Part 12: Starting performance of single-speed three-phase cage induction motors
IEC 60038	IEC standard voltages
IEC 60079-0	Explosive atmospheres - Part 0: General requirements
IEC 60079-31	Explosive Atmospheres Part 31: Equipment dust ignition protection by enclosure "t"
IEC 60079-7	Explosive Atmospheres - Part 7: Equipment protection by increased safety "e"
IEC 62262	Degrees of Protection Provided by Enclosures for Electrical Equipment Against External Mechanical Impacts (IK CODE)

Table 1 - Standards observed in the motor design

3. Environment

Unless otherwise specified, the rated outputs shown in the electrical data tables in this catalogue refer to continuous duty, S1, according to IEC 60034-1 and under the following operating conditions:

- Ambient temperature range from -30 °C to +40 °C.
- Altitudes not exceeding 1.000 masl.

When the operating temperatures and altitudes differ from those indicated above, you must apply the derating factors indicated in Table 2 to determine the useful power output (Pmax).

$$P_{max} = P_{nom} \times \text{Derating Factor}$$

T (°C)	Altitude (m)								
	1000	1500	2000	2500	3000	3500	4000	4500	5000
10							0,97	0,92	0,88
15						0,98	0,94	0,90	0,86
20					1,00	0,95	0,91	0,87	0,83
25				1,00	0,95	0,93	0,89	0,85	0,81
30			1,00	0,96	0,92	0,90	0,86	0,82	0,78
35		1,00	0,95	0,93	0,90	0,88	0,84	0,80	0,75
40	1,00	0,97	0,94	0,90	0,86	0,82	0,80	0,76	0,71
45	0,95	0,92	0,90	0,88	0,85	0,81	0,78	0,74	0,69
50	0,92	0,90	0,87	0,85	0,82	0,80	0,77	0,72	0,67
55	0,88	0,85	0,83	0,81	0,78	0,76	0,73	0,70	0,65
60	0,83	0,82	0,80	0,77	0,75	0,73	0,70	0,67	0,62
65	0,79	0,76	0,74	0,72	0,70	0,68	0,66	0,62	0,58
70	0,74	0,71	0,69	0,67	0,66	0,64	0,62	0,58	0,53
75	0,70	0,68	0,66	0,64	0,62	0,60	0,58	0,53	0,49
80	0,65	0,64	0,62	0,60	0,58	0,56	0,55	0,48	0,44

Table 2 - Derating factor considering altitude and ambient temperature.

Higher altitudes and wider ambient temperature ranges can also be provided upon request.

4. Construction Details

The information contained herein refers to the standard mounting features and the most common variants of the W51 HD line. Motors for special and/or customized application are also available on request. Please, contact the nearest WEG office.

4.1 Frame

Produced in cast iron FC-200, the frames of the W51 HD motors withstand high mechanical impacts, ensure maximum heat dissipation and high mechanical strength and reduce mechanical vibration even when transmitted by external sources. In addition, fins are distributed to have a greater heat dissipation area in the frontal area, which contributes to a uniform temperature distribution throughout the whole motor and reduces the DE bearing temperature. Thus, this unique fin distribution design ensures excellent thermal performance of the motor.

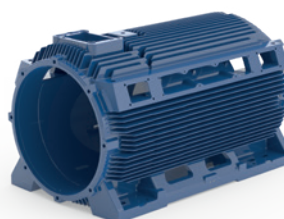

Figure 1 - Frame

W51 HD motors have longitudinal fins that ensure better thermal dissipation and solid and integrated cast feet which provide greater strength (see Figure 2).

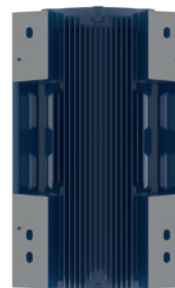

Figure 2 - Solid integrated cast feet ensuring high mechanical strength.

4.2 Eyebolts

To facilitate lifting to the different mounting positions, the W51 HD motors have multiple points for attaching eyebolts.

■ Motors with feet:

Standard: five points for attaching eyebolts.

Optional: nine points for attaching eyebolts (the five standard points plus four additional points - two on each motor foot).

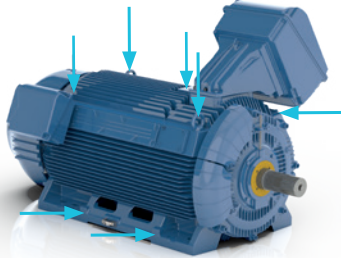

Figure 3 - Eyebolt fixing points for motors with feet.

Motors with two terminal boxes are provided with three main points for lifting eyebolts (two on the back and one in the center).

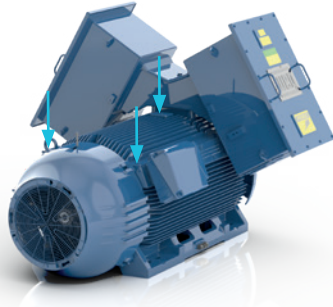

Figure 4 - Eyebolt fixing points for lifting motors with two terminal boxes.

■ Footless motor:

Standard: nine eyebolts (five at top side and four at bottom side).

Optional: nine standard eyebolt fixing points plus and one additional eyebolt fixing point located at the bottom side center.

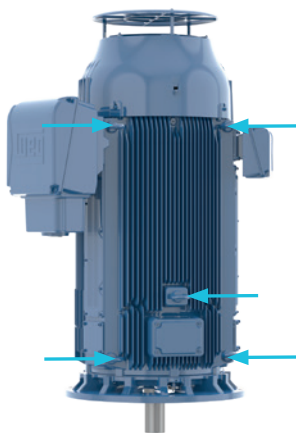

Figure 5 - Eyebolt fixing points for lifting footless motors (at the bottom side).

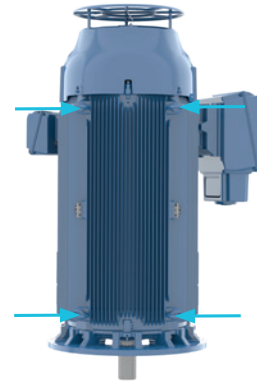

Figure 6 - Eyebolt fixing points for lifting footless motors (at the top side).

Note:

■ Horizontal motors:

For lifting of horizontal mounted motors use all eyebolts simultaneously. For this procedure, there are two ways: vertical chains (see Figure 7) and inclined chains (see Figure 8).

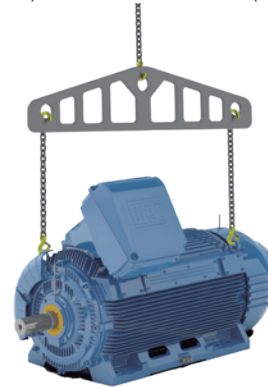

Figure 7 - Lifting with vertical chains.

For lifting motors with inclined chains, the maximum inclination angle of the chain during the lifting process should not exceed 30° in relation to the vertical axis. We recommend to use a spreader bar for maintaining the lifting elements (chain or ropes) in vertical position and thus preventing damage to the motor surface.



Figure 8 - Lifting with inclined chains.

■ **Vertical motors:**

For lifting of vertical mounted motors always use the eyebolts mounted at the top side of the motor, diametrically opposite, considering the mounting position (see Figure 9). In these cases, it is also necessary to use a spreader bar.



Figure 9 - Lifting of vertical motors.

■ **Motors with two main terminal boxes:**

For lifting of motors with two terminal boxes, use always three eyebolts as shown in Figure 10.



Figure 10 - Lifting of motors with two main terminal boxes.

4.3 Grounding Terminals

The W51 HD motors are fitted with grounding terminals on the frame (see Figure 11) and inside the main terminal box. These terminals can be positioned on the right or left side of the frame and have cross-section from 25 to 185 mm².

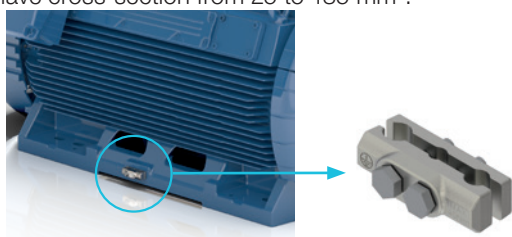

Figure 11 - Detail of the standard grounding terminal for the main terminal box and frame.

4.4 Grounding Brush

The safe area W51 HD motors can also be supplied with a grounding brush in the drive end as an optional item. For operation with variable frequency inverter, W51 HD motors are always fitted with shaft grounding brush at motor drive end (see Figure 12) and insulated non-drive end bearing (see Item 6.2.2), to avoid current flow along the motor shaft, across the bearing and return to the frame thus preventing premature bearing wear and failure due to electric currents flowing through them.

Note: W51 HD motors for hazardous areas cannot be supplied with a grounding brush. Motors for hazardous areas (Protection Type “ec” - Ex ec) and API 541 are supplied with a grounding cable between the terminal box and the frame, in addition to a grounding cable at the drive end for motors with both bearings insulated.

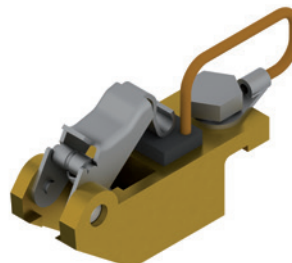

Figure 12 - Shaft grounding brush for bearing.

The W51 HD motors, can optionally be supplied with an AEGIS shaft grounding ring (see Figure 13) installed on the inner bearing cap. For external use can be supplied on request.

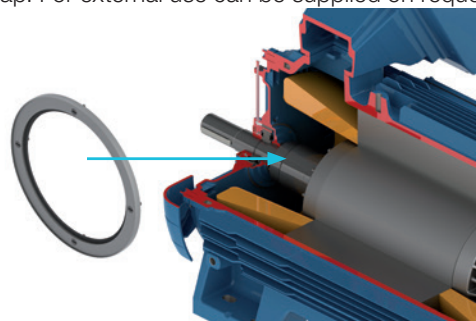

Figure 13 - AEGIS grounding ring.

Note: The incorrect specification and/or inadequate use of the grounding devices can cause serious damage to the machine and people involved in the operation of the motor. Before powering up the motor, ensure that it is properly grounded and that all grounding components are in perfect operating conditions.

4.5 Terminal Box

The W51 HD line has specific terminal boxes for motor power cables and accessory cable connections.

4.5.1 Main Terminal Box

It can be manufactured in cast iron FC-200 or steel plate, and due to its mounting it can be rotated in steps of 90°. The main terminal box has been designed for easier and ergonomically handling during cable connection procedures. In addition, the terminal box is mounted on a support on the top of the motor, allowing easy change of the terminal box position (see Figure 14).

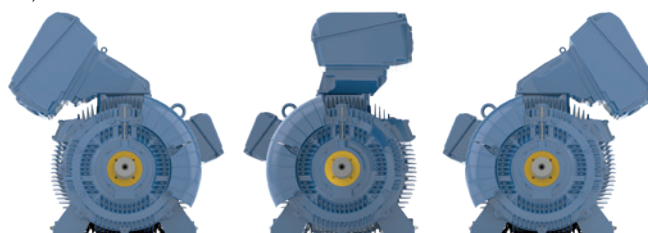

Figure 14 - Changing possibilities of the terminal box position.

Low voltage motors are supplied with six cables connected to a terminal block (see Figure 15), allowing direct online or star/delta starting.

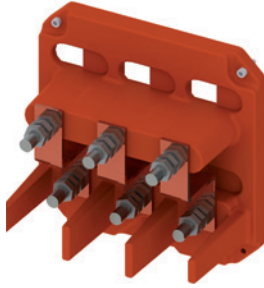

Figure 15 - Terminal block for low voltage motors with six terminals.

High voltage motors are supplied with three connection bolts and can be supplied with screws or connecting bars (see Figure 16).

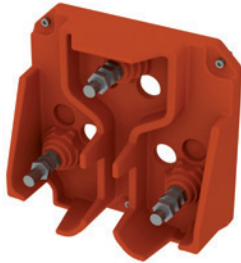

Figure 16 - Terminal block for high voltage motors with three terminals.

Note: The tightening torque of the terminals for motors with high and low voltage must comply with the standard DIN 46200.

The terminal box for high voltage motors is provided with a pressure relief device that ensures component integrity and user safety in case of short circuit. In case of activation of the pressure relief device, please contact WEG authorized servicing center. For safety reasons, this device must never be reassembled and never operate the motor without this safety device installed.

On request, the high voltage motors can also be supplied with an additional terminal box mounted at the opposite side of the main terminal box to enclosure the star point (see Table 18).

High voltage motors can be supplied with surge arrester and/or surge capacitors assembled in specific terminal box (see Section 12 Special accessories). For these cases, the main terminal box is supplied in steel plate (see Table 18).

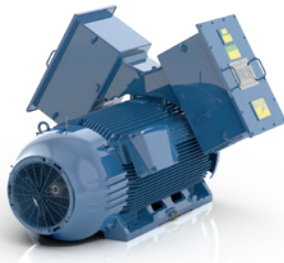

Figure 17 - Motor with access to neutral connection in separated terminal box.

4.5.2 Accessory Terminal Box

The W51 HD motors have a specific terminal box for connecting accessories. This box is also manufactured in cast iron FC-200 and comprises two compartments (see Figure 18).

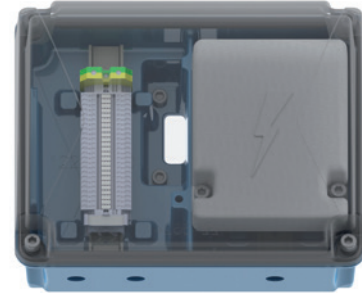

Figure 18 - Accessory terminal box.

4.6 Stator Winding

The stator windings of the W51 HD motors, regardless of voltage, are supplied with Class F insulation system and Class B temperature rise (80 K). Optionally, the motors can be supplied with Class H insulation system and Class B temperature rise (80 K). Other insulation system combinations can be supplied on request.

To monitor the motor heating, the windings are fitted with two sets of Pt-100 per phase and with a set of space heaters in order to prevent water condensation inside the motor. The space heaters are mounted in the air ducts on both sides of the motor, for easy maintenance (see Figure 19).

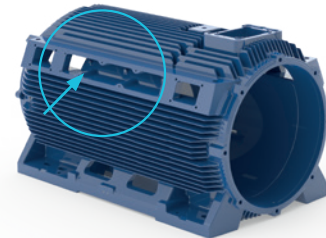

Figure 19 - Air ducts of the frame for air flow.

Since the lifetime of the motor is influenced by the temperature at which it operates, thus it is important to constantly monitor the winding temperature.

Note:

The space heaters must always be switched on when the motor is out of service for long periods and switched off when the motor is running, thereby preventing the deterioration of motor components and possible overheating.

The W51 HD High Voltage insulation systems are designed with mica tape layers and impregnated with epoxy resin through Vacuum Pressure Impregnation - VPI process and carefully manufactured and tested at factory thus ensuring a end product with high levels of reliability, preventing contamination of the impregnation varnish and ensuring voidfree impregnation of windings. For motors that operate with a non sine wave frequency inverter, insulation systems are reinforced to prevent accelerated aging of insulation (available on request).

4.7 Endshields

To improve heat dissipation and ensure lower operating temperatures on the bearing, the DE endshield is provided with fins uniformly distributed.

The endshields are manufactured in cast iron FC-200 and fastened with 8 bolts to ensure maximum rigidity (see Figure 20).

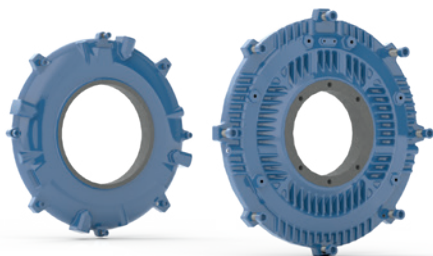

Figure 20 - DE endshield (left) and NDE endshield (right).

Depending on its mounting, the W51 HD can be provided with flange type "FF", as shown in Figure 21.

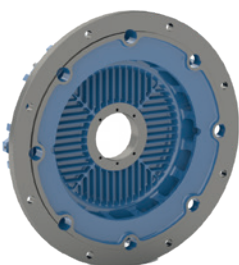

Figure 21 - DE endshield - Flange "FF".

4.8 Drains

W51 HD motors have holes for drainage of water that may condense inside of the frame or undesired entry into the motor, thereby preventing corrosion or damage to internal motor components.

W51 HD line has automatic drain plugs with degree of protection IP66 (see Figure 22) which do not require human intervention to open the plug and avoid accumulation of condensed liquids into the motor.

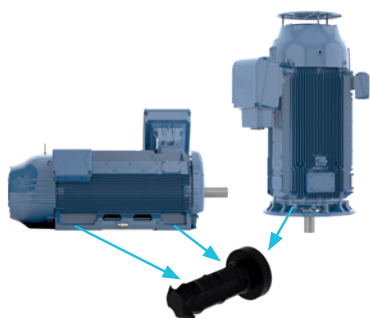

Figure 22 - Positions of automatic drains on the motors of the W51 HD line mounted in the horizontal and vertical position.

4.9 Fan Cover

The fan covers are built in cast iron FC-200 (see Figure 23), have an aerodynamic design, features high mechanical resistance to loads and impacts which allows their application in environments with risk of mechanical impact up to 5 Joules (IK08 according to standard IEC 62262).

For motors with sleeve bearings, the fan cover is made of steel plate with the same features as the cast iron version.



Figure 23 - Fan cover manufactured in cast iron FC-200.

The design of the fan cover, combined with the optimized fin distribution on the frame, ensures uniform air speed and minimizes the flow dispersion along the frame, and its shape guarantees increased efficiency of the ventilation system, which directly contributes to improving the motor thermal performance and energy efficiency. Attaching the fan cover directly to the frame adds strength to the set.

The W51 HD acoustic performance is guaranteed by a unique mounting system of the grille and internal baffle (see Figure 24), which ensures reduced noise below the levels established by the standards.

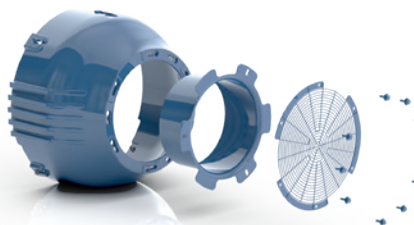

Figure 24 - Mounting system that ensures low noise levels.

4.10 Air Baffle

The W51 HD also has a pair of air baffles made of cast iron on the DE bearing. It was designed in order to guarantee a continuous and uniform airflow over the bearing housing, which significantly lowers its temperature and consequently increases relubrication intervals and bearing life (see Figure 25). Motors with sleeve bearings are supplied with two pairs of air baffles (see Figure 26).

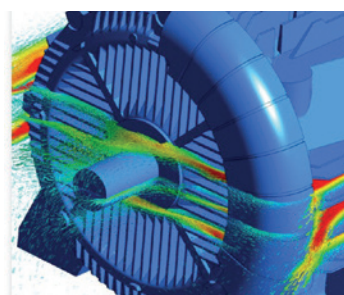

Figure 25 - Representation of the air flow over the DE bearing.



Figure 26 - Two pairs of air baffles for motors with sleeve bearings.

It is noteworthy to mention that for proper motor operation air inlets for motor ventilation are not blocked and that the space surrounding the equipment is enough to keep the air

temperature at the baffle inlet below the maximum temperature indicated on the motor main nameplate. For motors installed outdoors ensure that ventilation openings are not blocked and a minimum clearance of 1/4 of the baffle diameter is maintained from the walls to ensure free airflow for the ventilation system. For indoor installations, besides the minimum distance from walls, the air temperature must be checked at the air inlet of the ventilation system to prevent motor overheating. Motors installed outdoors or in vertical position require the use of additional shelter to protect them against the ingress of rainwater and/or solid particles, for instance the use of a drip cover.

Note: The mounting features of the fan cover must not be changed, because they are designed to ensure maximum efficiency of the fans.

4.11 Nameplate

The motors can be supplied with three types of nameplate: main, additional and warning nameplate. All nameplates are made of aluminium and the main and additional plates are laser engraved. Figure 27 shows the location of the nameplates on the W51 HD motor.

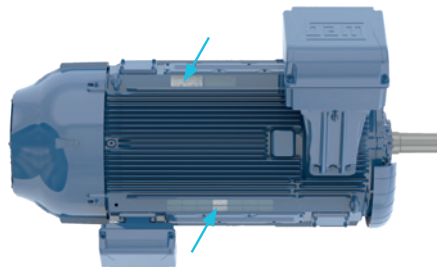

Figure 27 - Location of the nameplates on the electric motor.

4.11.1 Main Nameplate

The main nameplate provides information describing the mounting features and motor performance. It also provides the motor serial number and its year of manufacture. Figure 28 shows the layout of the nameplate on the W51 HD motor.

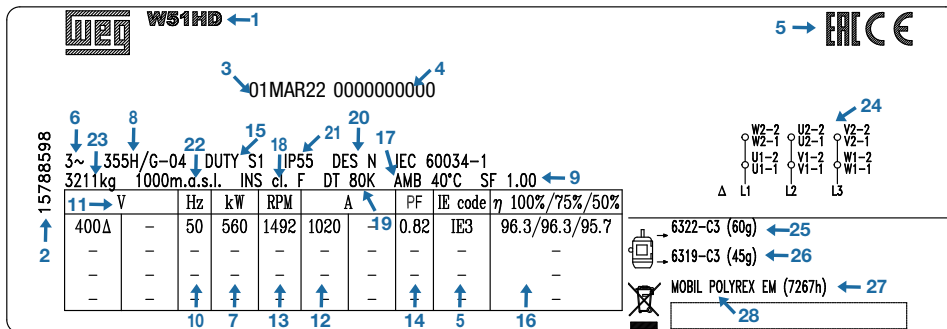

Figure 28 - Main nameplate of the motor.

- 1 - Motor line
- 2 - Motor code
- 3 - Manufacturing date
- 4 - Serial number
- 5 - Certification
- 6 - Number of phases
- 7 - Output power
- 8 - Frame model
- 9 - Service Factor
- 10 - Frequency
- 11 - Rated voltage
- 12 - Rated current
- 13 - Speed
- 14 - Power factor
- 15 - Duty cycle
- 16 - Efficiency
- 17 - Ambient temperature
- 18 - Insulation class
- 19 - Temperature rise of the windings
- 20 - Design
- 21 - Degree of protection
- 22 - Altitude
- 23 - Weight
- 24 - Wiring diagram
- 25 - DE bearing and grease quantity
- 26 - NDE bearing and grease quantity
- 27 - Bearing's relubrication interval (in hours)
- 28 - Grease type used for bearings

4.11.2 Additional Nameplate

To indicate the available accessories, the W51 HD motors are supplied with additional nameplates that contain informations on temperature sensors (see Figure 29 and Figure 30), space heaters (see Figure 31), and other accessories supplied on customer request. If required, these nameplates can be used to show the TAG codes specific to the motor.

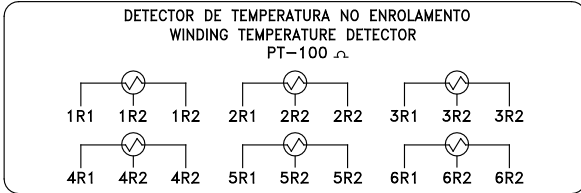

Figure 29 - Additional nameplate for winding temperature detectors (Pt-100).

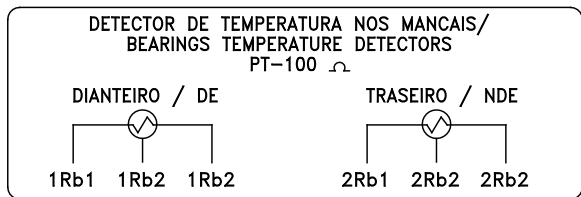

Figure 30 - Additional nameplate of the temperature sensor (Pt-100) for the bearings.

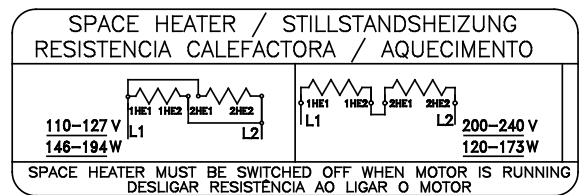

Figure 31 - Additional nameplate for the space heater.

Note: When motor is fitted with dual voltage space heaters, WEG supplies the motor connection set for 127 V. If required to connect to 220 V, the wiring diagram must be changed as shown on the additional nameplate of the space heater.

4.11.3 Warning Plate

Motors with rated voltage above 1 kV are supplied with a warning nameplate (see Figure 32), indicating the presence of high voltage on the motor. Never touch any energized circuits or rotating parts of the motor. Maintenance, installation and any interventions must be performed by qualified staff with appropriate tools only. For more details contact WEG technical support.

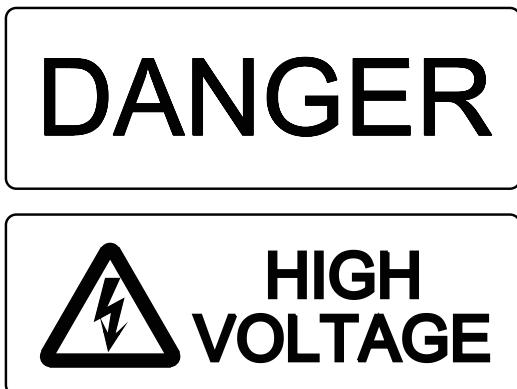

Figure 32 - Warning plate for motors above 1 kV.

5. Ventilation System/Noise Level/Vibration

5.1 Ventilation System

The motors of the W51 HD line comply with the specification of Totally Enclosed Fan Cooled motors (TEFC - IC-411) according to IEC 60034-6.

The optional version with forced ventilation (IC 416) can also be provided. On request, WEG can supply non-ventilated (TENV) and Air Over (TEAO) versions. Further information on the IC 416 option can be found in item "10.2 Operation with Frequency Inverter".

5.1.1 Fans

With an innovative ventilation system, W51 HD motors have a uniform distribution of internal temperature.

This system produces a pressure difference between the drive end and non-drive end of the motor, resulting in an air flow through the rotor cooling channels (see Figure 33). This air flow has its continuity ensured by the frame ducts, which complete the internal ventilation circuit (see Figure 34).

The internal ventilation system results in an homogeneous temperature distribution along the stator, and also helps to reduce the bearing temperature levels.

The internal ventilation system adopted for the W51 HD motors is simple and compact and provides the required air flow while increasing the cooling efficiency and reducing the vibration levels.

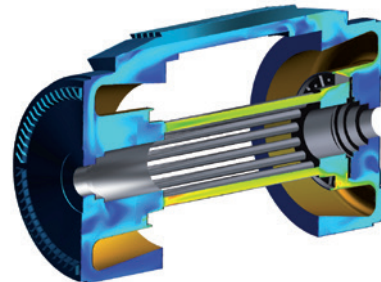

Figure 33 - Demonstration of the airflow through the rotor holes.

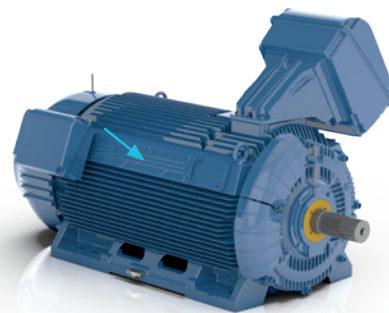

Figure 34 - Airflow channels in the motor frame.

Motors with four or more poles have an external radial fan with straight blades (see Figure 35) that ensures proper airflow even at lower speeds.

The external ventilation of two-pole motors is performed by an axial fan with inclined blades (see Figure 36), which ensures lower noise levels, with high ventilation capacity and efficiency. Made of cast iron FC-200, the fans are unidirectional for 2-pole motors and bidirectional for four or more poles.

As they use unidirectional fans, W51 HD two-pole motors require that the direction of rotation be informed in the order. Aluminum fans can also be supplied, but on request only.



Figure 35 - Radial fan with straight blades.



Figure 36 - Axial fan with inclined blades.

5.2 Noise Level

The noise level performance of W51 HD motors is indicated in Table 3.

The data refers to motors operating at 50 Hz and 60 Hz with fan covers made of cast iron.

Frame	Sound pressure level dB(A) - 50 Hz				Sound pressure level dB(A) - 60 Hz			
	2P	4P	6P	8P	2P	4P	6P	8P
315 G/F	81	80	74	70	84	82	76	73
355 H/G				73	85	83	78	76
400 H/G	84	82			86	85		
450 H/G	86	85	76	78	88	88	80	82

Table 3 - Sound pressure level for motors at 50 Hz and 60 Hz with fan cover made of cast iron.

The sound pressure levels shown in the Table 3 are valid for motors operating with no load and sine-wave power supply. Under load, IEC 60034-9 specifies a sound pressure level increase according to Table 4.

Height of the shaft end - H (mm)	2P	4P	6P	8P
H = 315	2	3	5	6
355 ≤ H		2	4	5

Table 4 - Maximum expected increase of the sound pressure level for motors operated with load.

Note: The sound pressure level increase for motors driven by frequency inverter that depends on the switching frequency of the inverter, may reach up to maximum 11 dB (A) according to IEC 60034-17 and IEC 60034-25.

5.3 Vibration

The vibration of an electrical machine is directly related to its installation conditions. For this reason, it is extremely important that the customer ensures a sturdy base and the required dimensional tolerances. To prevent equipment damage, vibration levels should be monitored regularly and any abnormal behavior must be immediately reported to the nearest authorized repair shop and/or to WEG. Motors with rolling bearings are highly sensitive to vibrations, and can suffer premature wear if exposed to vibrations above the acceptable limits.

It is recommended that vibration measurements be always performed before and after any maintenance or intervention on the equipment. Whenever possible, the vibrations generated only by the motor must be evaluated by no-load tests, following the procedures described in IEC-60034-14.

According to Table 5, the limits of maximum vibration magnitude in displacement, velocity and acceleration defined by IEC 60034-14 for motors operating at no-load are classified into vibration grade A and B.

Vibration grade	Mounting	Displacement (µm)	Velocity (mm/s)	Acceleration (m/s ²)
A	Free suspension	45	2,8	4,4
	Rigid mounting	37	2,3	3,6
B	Free suspension	29	1,8	2,8
	Rigid mounting	24	1,5	2,4

Table 5 - Limits of maximum vibration magnitude in displacement, velocity and acceleration according to the IEC- 60034-14.

When no special vibration requirements are specified in the Purchase Order, motors will be supplied in conformance with vibration grade A, while motors in conformance with vibration grade B will be supplied only on request. All rotors of the W51 HD motors are dynamically balanced with a half key and, as standard, are designed to vibration grade A. Motors with vibration severity level B can be supplied, but only upon prior consultation with WEG.

According to IEC- 60034-14, the standard motors are balanced to Grade G2.5. For special and lower vibration levels the balance quality grade is G1.6.

For vibration monitoring, the D-endshield of the W51 HD motors has three M8 threaded holes where vibration sensors can be fitted (see Figure 39). Optionally, these holes can be supplied with a threaded adapter for fitting the SPM vibration sensor (see Figure 37 and Figure 38).

Due to the air baffles, only two vibration sensors can be assembled on the D-endshield, one on the top and another on the opposite side of the air baffles. In case of changing the terminal box position (in example, to change the mounting from B3L(D) to B3R(E), the position of the air baffles and the threaded adapters for vibration monitoring should also be inverted.



Figure 37 - SPM Sensors.



Figure 38 - Threaded adapter for vibration measurement.

The frames also have flat areas for mounting of vibration sensors at the motor non-drive end. On request, non-drive endshields can be supplied with threaded holes for sensor mounting.

Figure 39 shows the measuring point locations. On request, the vibration sensors can be supplied with the motor.

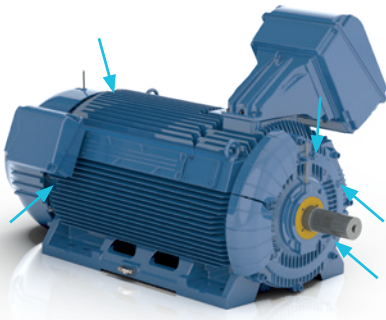

Figure 39 - Location of vibration measuring points.

5.3.1 Shaft Relative Vibration Limits

For machines with sleeve bearings with speed over 1,200 rpm and at rated power over 1,000 kW, IEC 60034-14 recommends relative shaft vibration measurements (see Table 6).

Sensor readings may be affected by mechanical and magnetic anomalies of the shaft, commonly referred to as runout.

Vibration grade	Speed range	Maximum vibration (µm)	Runout (µm) (peak-to-peak)
A	>1800	65	16
	≤1800	90	23
B	>1800	50	12,5
	≤1800	65	16

Table 6 - Maximum relative shaft displacement.

The shaft vibration limit for motors with sleeve bearing, including the shaft runout, must not exceed the limits of Table 7.

Synchronous speed (rpm)	Maximum Relative Shaft Vibration (peak-to-peak)
1801 – 3600	0.0028" (70µm)
≤ 1800	0.0035" (90µm)

Table 7 - Maximum relative shaft displacement for motors with sleeve bearing.

6. Shaft/Bearings/Stresses

6.1 Shaft

The shafts of the W51 HD motors comply with IEC 60072 and undergo several numerical analyses until reaching the final dimensioning. Among the evaluation steps are: calculation of fatigue considering the stress concentration, torsion, bending and traction-compression efforts, stress and deformation analysis, torsional and modal analysis.

In order to facilitate the maintenance and the coupling of loads, all motors have the shaft with threaded center hole.

The standard shaft material is AISI 4140 steel, and supplied with key type "C" according to ISO 2491. On request, WEG can also supply double-end shaft motors, shaft end with special dimensions, and shafts made of other materials. The dimensions for the shaft and can be found in Section 16 Mechanical Data.

6.2 Bearings

The standard motors are supplied with open ball bearings with C3 clearance and lubricated with grease. On request, motors with ball bearings can be supplied with C4 clearance.

All motors are supplied with Pt-100 temperature sensors in the windings as standard thus ensuring an efficient method for continuous temperature monitoring during operation.

W51 HD for Safety and Hazardous area are supplied with taconite labyrinth seals and, as an option, they can be supplied with taconite labyrinth with slinger, INPRO/SEAL and mechanical seal. Figure 40 shows the bearing construction form.

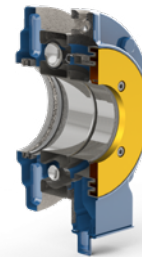

Figure 40 - Bearing construction form.

The vertical motors, for normal thrust loads can be supplied with ball bearings or angular contact ball bearings at the drive side, considering frame size and speed. This bearing configuration ensures optimum operating conditions for the motor in different applications and also prevents possible coupling problem caused due to thermal expansion.

The rated bearing lifetime, L10h, for direct coupling of the W51 HD line motors is 40.000 h (25.000 hours on frame size 450H/G 2-pole). Different bearing lifetime L10h can be evaluated on request.

The rolling bearing lifetime depends on the type and size of the bearing, the radial and axial loads they are subject, the operating conditions, the speed and grease life. Thus, its lifetime is closely related to its correct use, maintenance and lubrication. When the recommended amount of grease and lubrication intervals are respected, the bearings can reach the lifetime afore mentioned.

Note:

The bearing lifetime, L10h, in terms of operating hour, is the life that 90% of bearings is reached or even exceeded when motors are operated in compliance with the data provided in this catalog.

Table 8 lists the standard rolling bearings for different configurations of the W51 HD line.

	Frame	Number of poles	DE	NDE
Horizontal mounting	315 G/F	2	6314 C3	6314 C3
		4 – 12	6320 C3	6316 C3
	355 H/G	2	6314 C3	6314 C3
		4 – 12	6322 C3	6319 C3
	400 H/G	2	6220 C3	6220 C3
		4 – 12	6324 C3	6319 C3
450 H/G	2	6220 C3	6220 C3	
	4 – 12	6328 C3	6322 C3	
Vertical mounting Normal thrust	315 G/F	2	7314 C3	6314 C3
		4 – 12	7320 C3	6316 C3
	355 H/G	2	7314 C3	6314 C3
		4 – 12	7322 C3	6319 C3
	400 H/G	2	7220 C3	6220 C3
		4 – 12	7324 C3	6319 C3
	450 H/G	2	7220 C3	6220 M-C3
		4 – 12	7328 C3	6322 M-C3

Table 8 - Standard roller bearings per frame size.

The W51 HD motors can also be supplied with sleeve bearings with lateral flange and natural cooling (see Figure 41). This option ensures lower maintenance and longer bearing life in non-heavy duty applications with direct coupling. Depending on the customer requirements, other configurations can be supplied on request.



Figure 41 - Sleeve bearing.

Table 9 lists the standard models for motors with sleeve bearings.

	Frame	Number of poles	DE	NDE
Horizontal mounting with sleeve bearings	315 G/F	2	9-80	9-80
		4 – 12	9-90	9-90
	355 H/G	2	9-80	9-80
		4 – 12	9-100	9-100
	400 H/G	2	9-80	9-80
		4 – 12	11-110	11-110
	450 H/G	2	9-80	9-80
		4 – 12	11-125	11-125

Table 9 - Standard bearings per frame for motors with sleeve bearing.

Optionally, motors with horizontal mounting for applications with high radial loads can be supplied with roller bearings of the NU series, according to Table 10.

Frame	Number of poles	Roller bearing
		DE
315 G/F	4 – 12	NU320 C3
355 H/G		NU322 C3
400 H/G		NU324 C3
450 H/G		NU328 C3

Table 10 - Optional roller bearings of the NU series.

6.2.1 Shaft Locking Device

The W51 HD motors are fitted with a mechanical shaft locking device to prevent damage to the rotor and bearings during transportation (see Figure 42, Figure 43 and Figure 44). This locking device should only be removed right before installation and stored in a safe location for future transportation of the motor.

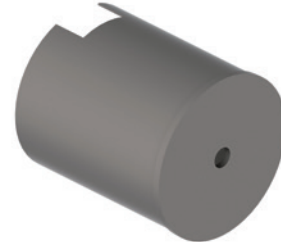

Figure 42 - Shaft locking device for motors with rolling bearing.

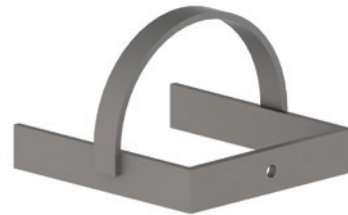

Figure 43 - Shaft locking device for motors with special bearing.

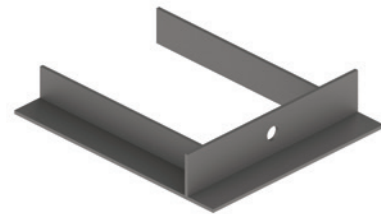

Figure 44 - Shaft locking device for motors with sleeve bearing.

6.2.2 Insulated endshield

In order to avoid bearing damage caused by electrical discharges generated inside the bearings, the W51 HD motors are fitted as standard with insulated NDE bearing (Figure 45). Currents flowing through the bearing have the potential of creating premature failure of these bearings, accelerating the degradation of the lubricant and of the bearing rolling elements. For all motors driven by frequency inverter, the electrical insulation of the NDE bearing and grounding between shaft and frame through grounding brush at drive end is mandatory.

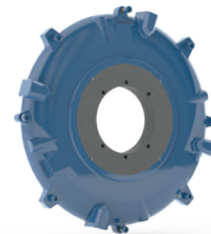

Figure 45 - Insulated NDE endshield.

On motors for hazardous area, the DE-bearing must never be grounded.

Horizontal motors with sleeve bearings, when required, both endshields may be supplied with insulation. Vertical motors with high thrust loads are also supplied with insulated DE bearing. For other configurations, contact WEG.

6.2.3 Lubrication

Bearing Lubrication

The W51 HD motors are fitted with a lubrication system with grease nipples on the DE and ND endshields, and a grease outlet drawer system for removing the old grease. The amount of grease and lubrication intervals are informed on the motor nameplate, and are also specified in Table 11.

	Frame	Number of poles	DE bearing	Grease (g)	50 Hz (h)	60 Hz (h)	NDE bearing	Grease (g)	50 Hz (h)	60 Hz (h)	
Horizontal mounting Ball bearings	315	2	6314	27	4500	3500	6314	27	4500	3500	
		4-12	6320	50		4500	6316	34		4500	
	355	2	6314	27	4500	3500	6314	27	4500	3500	
		4-12	6322	60		4500	6319	45		4500	
	400	2	6220	24	2700	2000	6220	24	2700	2000	
		4-12	6324	72	4500	3800	6319	45	4500	4500	
	450	2	6220	31	3500	-	6220	31	3500	-	
		4	6328	93	4500	3800	6322	60	4500	4500	
	6-12	4500									
	Vertical mounting Ball bearings	315	2	7314	27	Under request		6314	27	Under request	
4			7320	50	2700	2100	6316	34	4500	4200	
6-12					4500	4500			4500		
355		2	7314	27	Under request		6314	27	Under request		
		4	7322	60	1600	1600	6319	45	3500	3500	
		6			3900	2900			4500	4500	
8-12		4500			4500						
400		2	7220	24	Under request		6220	24	Under request		
		4	7324	72	1700	1200	6319	45	4500	3500	
		6			3300	2500			4500	4500	
8-12		4500			4500						
450		2	7220	31	Under request		6220	31	Under request		
		4	7328	93	2900	2000	6322	60	4300	3200	
		6			4200	4500					
8-12		4500			4500						
Horizontal mounting Roller bearings		315	4	NU320	50	4500	4200	6316	34	4500	4500
			6-12			4500	4500				
		355	4	NU322	60	3300	3300	6319	45	4500	4500
	6-12		4500			4500					
	400	4	NU324	72	3500	2400	6319	45	4500	4500	
		6-12			4500	4500					
	450	4	NU328	93	1100	600	6322	60	4500	4500	
		6			2900	2000					
		8-12			4500	4500					

Table 11 - Relubrication intervals and amount of grease for grease lubricated bearings.

It is extremely important to follow the lubrication intervals specified on the motor nameplate. An excessive or insufficient lubrication may increase the bearing temperature during operation, resulting in premature wear of the bearings and consequent reduction of their lifetime.

Table 12 specifies the standard type of grease for the motors and indicates some properties of the lubricating grease.

Frame	Number of poles	Lubricant	Lubricant specification
315	2 - 12	Mobil Polyrex EM	Grease with mineral oil, polyurea-based thickener, ISO VG 115
355			
400			
450			

Table 12 - Typical properties of the standard lubricant.

Note:

■ For operation of the motors under other than normal operating conditions, such as: ambient temperature above 40 °C, altitude higher than 1000 m above sea level and axial and/or radial load above the specified in Table 14 to Table 19, please refer to WEG.

■ The use of greases not recommended by WEG or in different amounts than specified above may void the product warranty.

Motors with ball bearings at the drive end (DE) and at the non-drive end (NDE) are fitted with bearings caps and locating bearing at DE and non-locating bearing at NDE with preload washer. When motor is fitted with roller bearing at the drive end, special bearing caps are assembled at the NDE where the locating bearing is assembled.

Sleeve Bearing Lubrication

Depending on the application the W51 HD motor can be supplied with sleeve bearings available on request. This type of bearing requires less maintenance ensures longer lifetime and relubrication intervals.

Table 13 provides key information about lubricants for sleeve bearings.

	Number of poles	Frame	Bearing	Relubrication interval (h)	Amount of oil (L)	Lubricant	Lubricant specification	
				50 Hz and 60 Hz				
Montagem horizontal mancais de deslizamento	2	315	9-80	8000	2,8	FUCHS Renolin DTA 10	ISO VG 32 mineral oil with antifoaming agents and antioxidant additives	
		355						
		400						
		450						
		315						9-90
		355						9-100
	4 - 8	400	11-110	8000	4,7	FUCHS Renolin DTA 15	ISO VG46 mineral oil with antifoaming agents and antioxidant additives	
		450	11-125					

Table 13 - Lubrication oil used in sleeve bearings.

6.3 Maximum Radial and Axial Loads

Table 14 to Table 19 show the maximum allowable radial and axial loads for the W51 HD motors. The values of the maximum load were calculated considering a L10h bearing lifetime of 40,000 h. The maximum radial load values consider the axial load equal to zero and the maximum axial load values consider the radial load equal to zero. For applications involving simultaneously axial and radial load, refer to WEG on bearing lifetime.

To determine the maximum allowable radial and axial loads on the motor shaft the following factors must be considered:

- Regular operating conditions.
- Shaft material: AISI 4140.
- 2-pole motors: parabolic torque load.
- 4, 6 and 8-pole motors: constant torque load.
- The values consider the application of a standard bearing for horizontal mounted motors.

6.3.1 Radial Loads

The values shown in Table 14, Table 15, Table 16 and Table 17 for the radial loads refer to the force applied to the center of the shaft end, L/2, and the end of the length of the shaft end L (see Figure 46).

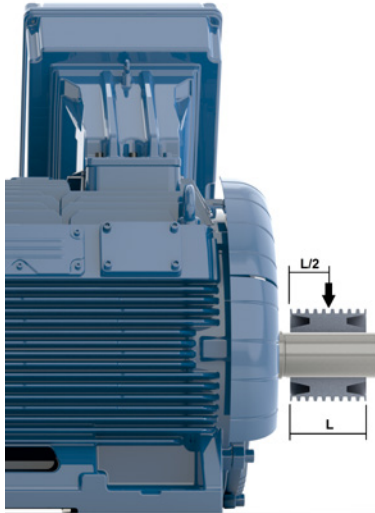

Figure 46 - Radial load applied to the shaft end.

Radial Load - Ball Bearing

Radial load - 50 Hz - Fr (kN)								
Frame	2P		4P		6P		8P	
	L/2	L	L/2	L	L/2	L	L/2	L
315	3	3	6.8	6.5	8.3			
355	2.5	2.4	6	5.7	8.4	7.9	10.5	9.9
400	Under request		6.1		7.1	6.7	7.6	7.2
450	Under request		6.9	6.4	8	7.5	9.2	8.7

Table 14 - Maximum allowable radial loads at 50 Hz for ball bearings.

Radial load - 60 Hz - Fr (kN)								
Frame	2P		4P		6P		8P	
	L/2	L	L/2	L	L/2	L	L/2	L
315	2.7	2.7	6	5.7	7.8	7.2	7.6	7.2
355	2.2	2.1			7.6	7.1	9.5	8.9
400	Under request		6.1	5.7	7	6.6	6.8	6.4
450	Under request				6.9	6.5	8.2	7.7

Table 15 - Maximum allowable radial loads at 60 Hz for ball bearings.

Radial Load - Roller Bearing

Radial load - 50 Hz - Fr (kN)						
Frame	4P		6P		8P	
	L/2	L	L/2	L	L/2	L
315	30	20	28	19	30	20
355	32	22	32	21	33	22
400	28	24	28	23	38	23
450	50	40	57	34	63	35

Table 16 - Maximum allowable radial loads at 50 Hz for roller bearings.

Radial load - 60 Hz - Fr (kN)						
Frame	4P		6P		8P	
	L/2	L	L/2	L	L/2	L
315	28	19	29	19	30	20
355	31	22	32	21	33	22
400	36	25	38	24	38	23
450	47	38	53	40	59	39

Table 17 - Maximum allowable radial loads at 60 Hz for roller bearings.

Note: Roller bearings require a minimum radial load (preload) to ensure proper operation. This type of bearing is not recommended for applications with direct coupling.

6.3.2 Axial Loads

Axial Loads for Horizontal Mounted Motors

The values shown in Table 18 indicate the maximum allowable values for axial load on the shaft end for horizontal mounted motors fitted with ball bearing.

Frame	Number of poles	Momentary traction or compression (kN)
315	2	2.0
	4	4.6
	6	5.9
	8	7.0
355	2	1.8
	4	4.9
	6	6.3
	8	7.6
400	2	1.5
	4	4.7
	6	5.8
	8	6.6
450	2	Under request
	4	5.5
	6	6.6
	8	7.8

Table 18 - Maximum allowable axial load for horizontal mounted motors.

Axial Loads for Vertical mounted motors

The values shown in Table 19 indicate the maximum allowable axial load on the shaft end for vertical mounted motors with normal thrust. The Table 19 considers DE bearing with angular contact.

Frame	Number of poles	Thrust (kN)	Momentary compression (kN)
315	2	Under request	
	4	15.4	4.6
	6	18.8	5.9
	8	21.5	7.0
355	2	Under request	
	4	15	4.9
	6	18.2	6.3
	8	21.2	7.6
400	2	Under request	
	4	11.1	4.7
	6	13.5	5.8
	8	16.5	6.6
450	2	Under request	
	4	14.9	5.5
	6	17.5	6.6
	8	20.5	7.8

Table 19 - Maximum allowable axial load for vertical motors with normal thrust.

7. Mounting Forms

The standard motors are supplied in the B3 - mounting (see Figure 47), with the terminal box on the left side of the frame, looking at the non-drive end of the motor. The mounting designation for the W51 HD motors designation the IEC 60034-7. Different mounting can be supplied, as shown in Table 20 and Table 21.

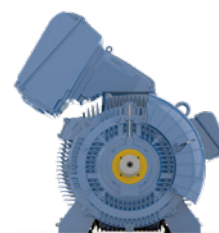

Figure 47 - B3R mounting.

Mounting								
	WEG Reference	B3R	B3L	B3T	B35R	B35L	B35T	
Details	Frame	With feet	With feet		With feet	With feet		
	Shaft end	Left	Right		Left	Right		
	Fixation	Base or rails	Base or rails		Base or FF flange			
Mounting								
	WEG Reference	V15R	V15L	V15T	B5R	B5L	B5T	V1
Details	Frame	With feet			Without feet	Without feet		Without feet
	Shaft end	Downwards			Left	Right		Downwards
	Fixation	Wall or FF flange			FF flange	FF flange		FF flange
Mounting								
	WEG Reference	V5R	V5L	V5T	V6R	V6L	V6T	
Details	Frame	With feet			With feet			
	Shaft end	Downwards			Upwards			
	Fixation	Wall			Wall			

Table 20 - Mountings.

The Table 21 shows the availability of mountings per frame size.

Frame / Mounting	B35L	B35R	B35T	B5L	B5R	B5T	V1	V15L	V15R	V15T	V5L	V5R	V5T	V6L	V6R	V6T
315 G/F	0	0	0	0	0	0	0	0	0	0	0	0	0	0	0	0
355 H/G	0	0	0	0	0	0	0	0	0	0	0	0	0	0	0	0
400 H/G	0	0	0	0	0	0	0	0	0	0	0	0	0	0	0	0
450 H/G	0	0	0	Under request			0	0	0	0	0	0	0	0	0	0

Legend: 0 - Optional

Table 21 - Availability of mountings per frame size.

8. Degree of protection/Bearing sealing/Painting

8.1 Degree of Protection

W51 HD for safe and hazardous area motors are supplied with degree of protection IP55, according to IEC 60034-5 requirements.

W51 HD motors can also be supplied with higher degree of protection, as indicated below:

- IP56 for increased degree of protection against water.
- IP65 for increased degree of protection against dust.
- IP66 for increased degree of protection against dust and water.

8.2 Bearing Sealing

The bearing sealing used on the endshields of the W51 HD motor is the taconite labyrinth, which ensures the degree of protection IP55 for the motor frame according to IEC 60034-5.

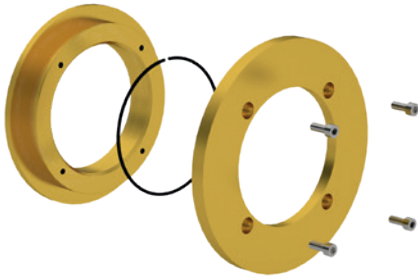

Figure 48 - Taconite Labyrinth

This sealing system protects the motor against the ingress of dust and water into the frame present in the environment.

8.3 Painting

The W51 HD motors can be applied in severe industrial environments, in sheltered locations or outdoors, in the presence of SO₂, steams and solid contaminants, high humidity indexes, alkali and solvent splashes. The painting plan of the motors ensures a minimum of 1,000 hours of corrosion resistance in the test by salt spray chamber according to ASTM B117-03 and corrosion category C4, according to ISO 12944-2.

Optionally, W51 HD motors can be supplied with painting plans that have a corrosion classification C5 and CX in accordance with ISO 12944-2.

8.3.1 Internal Anti Corrosive Painting

High humidity indexes can result in premature insulation system deterioration which is the main component that ensures the motor lifetime. Motors applied in environments with relative air humidity of about 95% do not require additional protections beyond the space heater to prevent moisture condensation inside the motor.

However, for use in environments with humidity indexes above 95%, it is recommended to apply an epoxy coating on the internal parts of the motor, also known as tropicalized painting.

9. Voltage/Frequency

According to IEC 60034-1, the combinations of voltage and frequency variations are classified as Zone A or Zone B (see Figure 49).

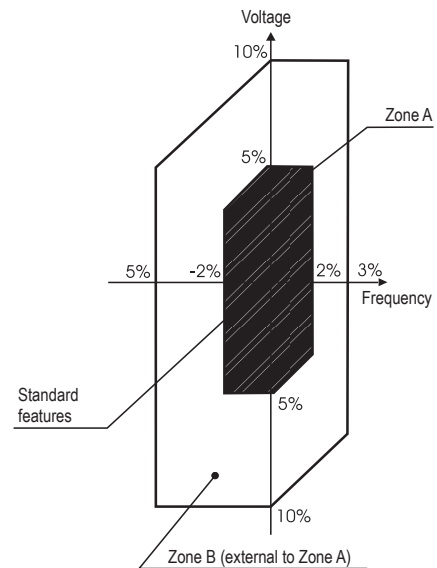

Figure 49 - Limits of voltage and frequency variations under operation.

A motor must be capable of performing its main function continuously at Zone A, however it may not develop completely its performance characteristics at rated voltage and frequency showing few deviations. Temperature rises can be higher than those at rated voltage and frequency. A motor must be capable of performing its main function at Zone B, however it may present higher deviations than those of Zone A in reference to performance characteristics at rated voltage and frequency. Temperature rises can be higher than those at rated voltage and frequency and probably higher than those of Zone A. The extended operation at Zone B is not recommended.

10. Operation Characteristics

During installation and any intervention on the machine, all recommendations for handling, lifting and maintenance must be observed.

10.1 Thermal Protection

In order to monitor the operating condition of the motor, all the W51 HD motors are fitted with temperature sensors in the windings and on the bearings.

In its standard version, the motors are fitted with two resistance temperature detector (Pt-100) with three wires per phase and one resistance temperature detector (Pt-100) per bearing (see Figure 50).

Motors with sleeve bearing use Pt-100 with connection head (see Figure 51), fixed directly to the bearing. These devices generally have three wires, but they can be supplied with 2, 4, 6 (duplex) and 8 cables (duplex), and can be supplied calibrated and/or certified.

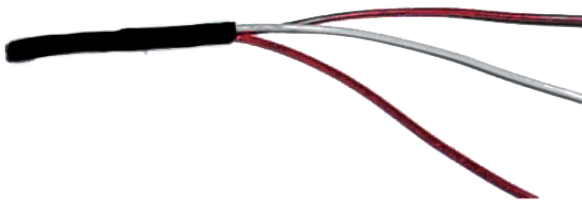

Figure 50 - Pt-100



Figure 51 - Pt-100 with connection head.

- **Thermostat:** bimetallic thermal protectors with silver contacts, NC type (normally closed), which open when predetermined temperature rise is reached. When the activation temperature of the bimetal thermal protector decreases, the thermostat will return to its original position instantaneously allowing to close the contact and the consequent restart of the motor. The thermostats are series connected to the motor coil, and thus can be used for switching off the motor. A second set of bimetal thermal protectors can be used for the alarm, however in this case it must be connected to a specific alarm circuit.
- **PTC Thermistors:** increase their resistance very fast with temperature increase. The sudden change in resistance interrupts the current in PTC, activates an output relay, which turns off the main circuit (see Figure 52).



Figure 52 - PTC Thermistor.

The thermistors have reduced size, do not have mechanical wear, and provide faster response when compared to other temperature sensors. However they do not allow continuous monitoring of the motor heating process. Thermistors with their electronic circuit controls ensure complete protection against overheating caused by phase-fault, overload, under/overvoltages or frequent reversals of direction of rotation or on/off cycles.

10.2 Operation with Frequency Inverter

The W51 HD motors have a design suitable for applications with variable speed. The standard motor is designed for sine wave filter inverter operation, otherwise a motor with reinforced insulation must be supplied.

All W51 HD motors fitted with rolling bearings have rigid shafts, avoiding the need of skipping frequencies on the inverter in the operating range, however, for speeds above the catalog limits, contact WEG. The W51 HD motors can be supplied for high speed version (up to 5,000 rpm), also on request.

10.2.1 Influence of the Frequency Inverter on Temperature Rise of the Motor

The induction motor may present a higher temperature increase when fed by a frequency inverter, than when fed with sine wave voltage. This overtemperature rise is due to the combination of two factors: the increase of losses on the motor as a function of the harmonic components of the PWM voltage supplied by the inverter, and the reduction of the effectiveness of the ventilation system when the self-ventilated motor operates at low frequencies. Basically the following solutions can be used to prevent the motor overheating:

- Reduction of the rated torque.
- Use of an independent ventilation system (forced ventilation).

Criteria for Torque Reduction

In order to maintain the temperature of the motors within acceptable levels when operating with frequency inverters and without forced ventilation, the load limits shown in Figure 53 must be observed (derating curve of the W51 HD motor).

This torque reduction is a required solution when the motor drives a load with constant torque. In order to drive loads with quadratic torque, usually it is not necessary to apply any torque reduction factor.

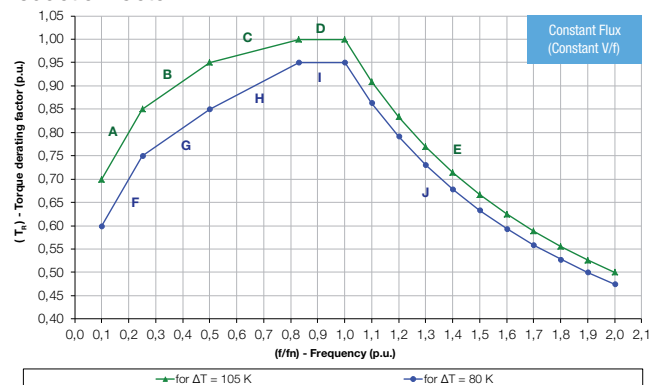

Figure 53 - Derating curve for motors driven by frequency inverter.

For more information on motors operated with frequency inverter, refer to the **Technical Guide - Induction motors fed by PWM frequency inverters (50029350)**, which can be found at www.weg.net.

10.2.2 Forced Ventilation Kit

Motors driven by frequency inverter at low speeds generally require an independent ventilation system. In these cases, the application of a forced ventilation kit ensures constant cooling of the motor throughout its speed range.

The forced ventilation kit (see Figure 54) comprises a 4-pole motor with independent power supply from the main motor, and it is not subject to its operating conditions.

This ventilation kit uses a motor with natural cooling method (IC410 or IC40).

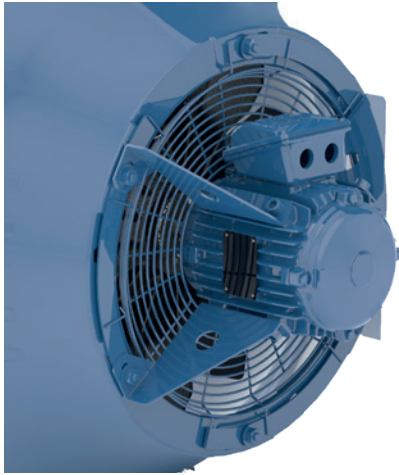

Figure 54 - Detail of the assembly of the forced ventilation kit with cast iron air baffle.

The supply voltages available for the forced ventilation kit of the W51 HD motors are listed in Table 22.

Supply voltage available for the forced ventilation kit (V)
208-230/460
220-240/380-415
220/380-440
380-415/660
525-550
575
220/380
220/440
230/460
240/480
380/660
400/690
440
460
480

Table 22 - Supply voltages available for the forced ventilation kit.

Note:

- Motors with forced ventilation kits present an increase of 3 dB(A) in the noise level, without taking into account the noise produced by the frequency inverter. Since the global noise value depends on the inverter switching frequency, for more precise information, contact WEG.
- The use of the forced ventilation kit changes the motor length. In Section 12 is possible to check the motor length increase due to the use of the forced ventilation kit.

10.2.3 Common-Mode Voltages

The common mode voltages occur when the sum of the voltages at the inverter output is different from zero. They are the main reason why currents flow through the motor bearings driven by static inverter. These currents wear the balls and the ball bearing races, reducing the bearing lifetime and causing premature failures. The W51 HD motors are supplied with shaft grounding brushes to prevent the current flow through the bearing and this avoid its premature failure, see "4.4 Grounding Brush".

11. Installation Characteristics

Some important aspects must be taken into account when dimensioning the installations of the W51 HD motors, which are described below.

11.1 Strength and Mass of the Motor Mechanical Support System (MSS)

Regardless the mounting type or design of the motor Mechanical Support System (MSS), the assembly must be strong enough with relatively high mass.

Several tools can be used to evaluate the strength of the foundation, such as experimental or numerical analysis. The base must present vibration levels less than 30% of the vibration measured on the motor in positions next to the fixation points in the horizontal, vertical and axial directions. The design of the base must also ensure that its the natural frequencies does not match the running frequency of the motor, also keeping a separation of $\pm 5\%$ from the natural frequency to twice and three times the speed frequency and to once and twice the power line frequency (60 e 120 Hz). Motors that operate with frequency inverter and variable mechanical speed must have the natural frequencies of the system removed from the inverter operating range, so that there are no natural frequencies of the whole system (motor + base + driven equipment) throughout this operating range.

Metal fixtures of the motor must feature anchors securely fastened to the foundation anchor plate, avoiding the connection to the motor only with metal parts.

Since structural steels absorb little external vibration and do not damp the motor vibrations, the global vibration and noise levels may increase.

The base design must be robust and withstand the motor without significant deformation, taking into account the mass and stresses on the foundation informed by WEG on the motor data sheet.

11.2 Dimensional Control

The dimensional control must be precise, with tolerance for flatness, parallelism and perpendicularity between the supports, avoiding soft foot or motor misalignment.

The area of the motor footrests in the drive end and non-drive end must be identical. The foundation must also guarantee 100% support of the DE foot, and the NDE foot must have a support area identical to the DE part or 50% of the total area of the foot (consider the highest value when designing the support).

The foot flatness must be controlled for each motor. W51 HD motors can have flatness of the feet below 0.127 mm according to IEEE 841 standard.

Vertical mounted motors must be mounted on rectangular or round, solid, steel plates with a hole in the center for the shaft extension. The flange support surface must be machined, with threaded or throughout holes, but the fastening screws must be tightened with controlled torque on flat surfaces.

The steel plate must be at least three times thicker than the machine flange (WEG recommend five times). This mounting base plate must be securely fastened to a solid and leveled surface (in compliance with IEC 60034-14 requirements).

The correct number and diameter of fasteners must be used to connect the flange.

12. Special Accessories

Some special accessories can be installed on the W51 HD motors for specific functions, such as speed control, temperature monitoring, and protection against oscillations of the power line or lightning discharges.

12.1 Encoder

For precise speed and shaft position control in critical applications, the W51 HD Safe Area motors can be supplied with an encoder. For W51 HD Hazardous Area motors with encoders, contact WEG.

WEG recommends the use of the following encoders:

- Dynapar- series B58N- 1,024 ppr and 2,048 ppr (hollow shaft). This encoder is easy to mount and ensures good precision (see Figure 55).



Figure 55 - Dynapar B58N Encoder.

- Leine Linde - 861 - 1,024 ppr and 2,048 ppr (hollow shaft). It can also be supplied as an optional item and offers good precision (see Figure 56).



Figure 56 - Leine Linde 861 Encoder.

Other encoder models can be supplied on request.

Note: Mounted on the non-drive end of the motor and directly coupled to the shaft extension, the use of this device increases the motor length, which varies according to the encoder.

12.2 Protection Against Voltage Surge

The terminal box of the motor of the W51 HD high-voltage line can be equipped with a surge arrester per phase (see Figure 57). These components are classified according to the following voltage classes: 3 kV, 6 kV, 9 kV or 12 kV.



Figure 57 - Surge arrester.

Besides the surge arrester, the high-voltage motors also have a surge capacitor per phase as special component (see Figure 58). These devices are installed in the main terminal box and their application recommended in systems potentially subject to voltage peaks during switching operations or lightning discharges. The surge capacitors are installed in a stainless steel enclosure and have the following features:

Capacitance – 0,5 μ F
 Rated voltage – up to 7,2 kV
 Voltage class – 15 kV

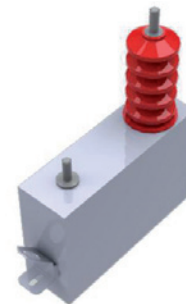

Figure 58 - Surge capacitor used in the W51 HD line.

12.3 Leveling Screw

In order to ensure perfect alignment between the driven machine and the motor, WEG supplies the leveling screws set as an accessory. These components must be used only during the motor installation and must be removed after the shims are placed between the foundation and the machine.

12.4 Non-Reverse Ratchet

Some applications do not allow the inversion of direction of rotation. In order to prevent this reversal, the W51 HD motors must be fitted with the non-reverse ratchet (see Figure 59).



Figure 59 - Non-reverse ratchet.

12.5 Thermometer

In order to monitor the bearing temperature, for both rolling bearing and sleeve bearing, the motors can be fitted with thermometers.

On the rolling bearings, one thermometer can be installed on each endshield, and for sleeve bearings, thermometers can be installed on the bearing shell or oil tank.

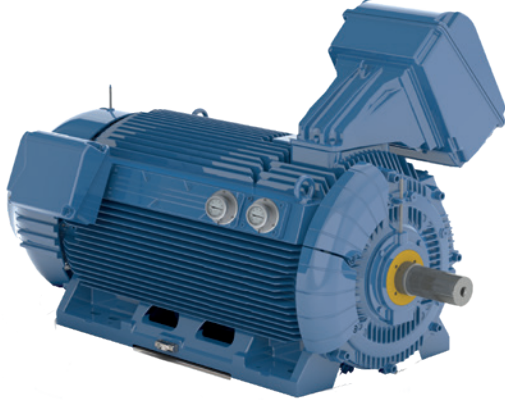

Figure 60 - Thermometers with sights located on the sides.

12.6 Interchangeability Solutions

With the technological progress, machines are increasingly smaller and more efficient, which consequently results in interchangeability problems, especially for older motors or from different manufacturers. In order to solve this problem, the W51 HD motors can be supplied with an intermediate base (see Figure 61) or also with dimensional variations, especially on feet and frame.

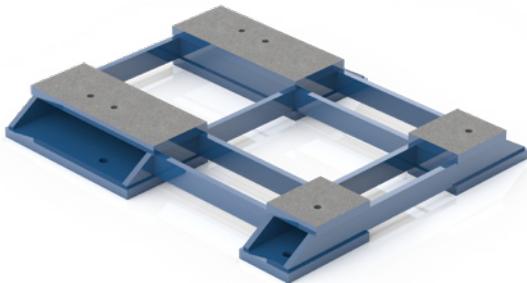

Figure 61 - Intermediate base.

If you need to replace a motor with a frame (shaft end height) immediately above the power standard, the motor can be supplied with a foot extension.

If it is necessary to use the height of two frames above (for example, replace frame 315 with frame 400), the motors can be supplied with intermediate steel base. For this case, the upper part of the base features the fixation drilling of the standard motor in the required power, and the lower base the fixation drilling of two frames immediately above.

12.7 Automatic Lubricator

The automatic lubricator available for the W51 HD motors reduces the motor maintenance, especially in applications in which the motor is in a place with difficult access and high ambient temperature or speeds.

The lubricator, when supplied with the motor, has polyurea based grease and it is configured for the lubrication intervals specified on the motor nameplate. The grease canister must be replaced with the same grease or compatible grease in order to ensure smooth motor operation.

The grease outlet works by the same way of the motors with grease nipple.

Easily-accessible, the lubricator is mounted on the motor sides (see Figure 62).

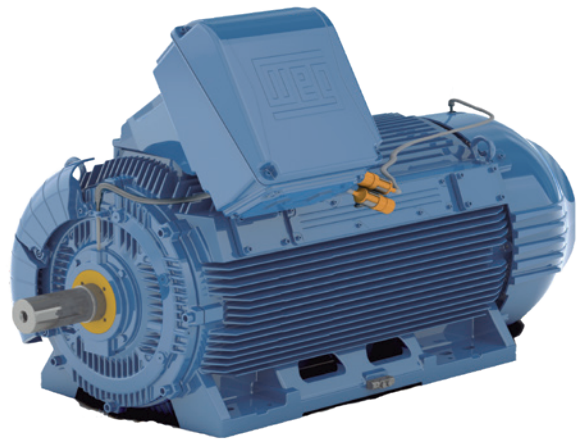

Figure 62 - Lubricator located on the sides.

13. Construction Features

Frame		315 G/F	355 H/G	400 H/G	450 H/G	
Mechanical features						
W51 HD Hazardous Area Marking		Ex ec IIC T3/T4 Gc				
		Ex tb IIIC T125°C/T160°C Db				
		Ex tc IIIB T125°C/T160°C Dc				
Mounting		B3D				
Frame Material		Cast Iron FC-200				
Degree of protection		IP55				
Grounding		Double grounding (1 terminal box + 1 frame)				
Cooling method		TEFC				
Fan Material	2P	Cast Iron FC-200				
	4P - 12P					
Fan cover Material		Cast Iron FC-200 (ball bearings) - Steel (sleeve bearings)				
Endshields Material		Cast Iron FC-200				
Drain plug		Automatic drain plug IP66				
Bearing	Shielded/clearance DE	2P	C3			
		4P - 12P				C3
	Shielded/clearance NDE		C3			
	Locating bearing		Fixed on DE with external and internal bearing cap and preload spring NDE			
	Drive end	2P	6314	6314	6220	6220
		4P - 12P	6320	6322	6324	6328
	Non-drive end	2P	6314	6314	6220	6220
4P - 12P		6316	6319	6319	6322	
Sleeve bearings	Axial clearance		4 mm			
	Locating bearing		Located both bearings			
	Drive end	2P	9-80	9-80	9-80	9-80
		4P - 12P	9-90	9-100	11-110	11-125
	Non-drive end	2P	9-80	9-80	9-80	9-80
4P - 12P		9-90	9-100	11-110	11-125	
Bearing seal		Taconite Labyrinth				
Joint seal		Without				
Lubrication	Type of grease		Mobil Polyrex EM			
	Grease fitting		With grease fitting			
Terminal block		With Terminal block				
Terminal box material		Cast Iron FC-200				
Lead inlet	Main up to 1 kV	Size	2xM63x1.5	2xM80x2.0		
			M63x1.5			
	Additional	3xM20x1.5				
	Plug		Plastic threaded plug			
Shaft	Material		AISI 4140			
	Threaded hole	2P	M20			
		4P - 12P	M24			
Shaft key		C key				
Vibration level		Grade A				
Balancing without/half/full key		With 1/2 key				
Nameplate material		Laser printed Aluminium				
Painting	Type		214P			
	Color		RAL 5009 (Blue)			
Electrical features						
Design	Up to 1 kV	2P - 8P	Design N			
		10P - 12P	Not Applicable			
1 to 6,6 kV						
Voltage	Single speed		380 V to 6600 V			
Winding	Impregnation	Up to 1 kV	Resin continuous flow			
		1 to 6,6 kV	VPI			
	Insulation class		F (DT 80 K)			
Space heater	W51 HD Safe Area		110-127 / 220-240 V			
	W51 HD Hazardous Area		200-240 V			
Service factor		1,00				
Ambient temperature	Maximum		+40 °C			
	Minimum		-20 °C			
Starting method		DOL				
Rotor		Aluminium or copper according to the motor output (for further information, consult WEG)				
Winding thermal protection		Pt-100 3 leads (2 per phase)				
Bearing thermal protection		Pt-100 3 leads (1 per bearing)				

14. Optional Features ^{1) 2)}

Frame		315 G/F	355 H/G	400 H/G	450 H/G
Mechanical optionals					
Terminal box type					
Steel		0	0	0	0
Terminal block (W51 HD Safe Area)					
Terminal block	Up to 1 kV	0	0	0	0
	1 to 6,6 kV	SD	SD	SD	SD
Connection bolt	Up to 1 kV	SD	SD	SD	SD
	1 to 6,6 kV	0	0	0	0
Terminal block (W51 HD Hazardous Area)					
Terminal block	Up to 1 kV	SD	SD	SD	SD
	1 to 6,6 kV	SD	SD	SD	SD
Connection bolt	Up to 1 kV	0	0	0	0
	1 to 6,6 kV	0	0	0	0
Cable gland					
Without cable gland		SD	SD	SD	SD
Plastic ³		0	0	0	0
Brass		0	0	0	0
Stainless steel ³		0	0	0	0
Flange					
Without flange		SD	SD	SD	SD
Flange FF		0	0	0	0
Flange C		0	0	0	-
Fan					
Cast iron		SD	SD	SD	SD
Aluminium		0	0	0	0
Bronze		0	0	0	0
Steel		0	0	0	0
Drive end bearing type					
Ball bearing (horizontal mounting)		SD	SD	SD	SD
Angular contact ball bearing (vertical mounting/ 2 Poles)		SD	SD	SD	SD
Ball bearing (vertical mounting / 4-12 Poles)		SD	SD	-	-
Angular contact ball bearing (vertical mounting/ 4-12 Poles)		-	-	SD	SD
Rolling bearing NU (4-12 Poles)		0	0	0	0
Sleeve bearing (Insulated)		0	0	0	0
Non-drive end bearing type					
Ball bearing		SD	SD	SD	SD
Sleeve bearing (Insulated)		0	0	0	0
Insulated drive endshield hub					
Non insulated		SD	SD	SD	SD
Insulated bearing		0	0	0	0
Insulated end shield		0	0	0	0
Insulated non-drive endshield hub					
Insulated end shield		SD	SD	SD	SD
Insulated bearing		0	0	0	0
Non insulated		0	0	0	0
DE and NDE bearing seal (W51 HD Safe Area and W51 HD Hazardous Area)					
Taconite labyrinth		SD	SD	SD	SD
INPRO/SEAL		0	0	0	0
Taconite labyrinth with slinger		0	0	0	0
Mechanical seal		0	0	0	0
Joint seal (W51 HD Safe Area and W51 HD Hazardous Area)					
Loctite 5923 (Permatex) on joints		0	0	0	0
Shaft					
Shaft locking device		SD	SD	SD	SD
Second shaft end		0	0	0	0
Balance type					
Balancing without key		0	0	0	0
Balancing with full key		0	0	0	0
Key					
B key		0	0	0	0
C key		SD	SD	SD	SD
Vibration level					
Grade A		SD	SD	SD	SD
Grade B		0	0	0	0
According to API		0	0	0	0
Lubrication					
Aeroshell 7		0	0	0	0
Isoflex NBU 15		0	0	0	0
Oil Mist		0	0	0	0
Grease fitting					
Carbon steel grease fitting		SD	SD	SD	SD
Threaded grease fitting NPT 1/4"		0	0	0	0
Grease fitting able to Oil Mist		0	0	0	0
Grease outlet					
Grease outlet by plastic slide valve		SD	SD	SD	SD
Grease outlet through endshield		0	0	0	0

Notes:

1) Other optional features, on request.

2) Some combinations of optional features are not allowed - then contact WEG.

SD - Standard / O - Optional

14. Optional Features ^{1) 2)}

Frame	315 G/F	355 H/G	400 H/G	450 H/G
Drain (W51 HD Safe Area)				
Automatic drain plug IP66	SD	SD	SD	SD
Threaded drain plug (closed)	0	0	0	0
Threaded T-type drain plug (automatic)	0	0	0	0
Drain (W51 HD Hazardous Area)				
Automatic drain plug IP66	SD	SD	SD	SD
Threaded drain plug in stainless steel (closed)	0	0	0	0
Degree of protection (W51 HD Safe Area and W51 HD Hazardous Area)				
IP55	SD	SD	SD	SD
IP56	0	0	0	0
IP65	0	0	0	0
IP66	0	0	0	0
Painting plan				
214P - ISO 12944 C4 durability class "Medium" - Indicated for aggressive sheltered and non-sheltered environment. Industrial application that allows SO ₂ , steams, solid contaminant, high humidity and alkali and solvent sprinkles presence.	SD	SD	SD	SD
212E - ISO 12944 C5 (I and M) durability class "High" - Indicated for marine aggressive environment or marine industrial environment, sheltered allowing high humidity and alkali and solvent sprinkles presence. Indicate to pulp and paper, mining and chemical industrial applications.	0	0	0	0
212P - ISO CX/C5 (I and M) durability class "Very High" - Indicated for marine aggressive environment or marine industrial environment, sheltered or nonsheltered, allowing high humidity presence. Indicate to pulp and paper, mining and chemical industrial applications.	0	0	0	0
Internal tropicalized painting (epoxi)	0	0	0	0
Other mechanical optionals				
Ventilated bearing	SD	SD	SD	SD
Drip cover	0	0	0	0
Special flatness in the feet - Guide pin	0	0	0	0
IOT optionals				
WEG Motor Scan	0	0	0	0

Notes:

1) Other optional features, on request.

2) Some combinations of optional features are not allowed - then contact WEG.

SD - Standard

0 - Optional

14. Optional Features ^{1) 2)}

Frame	315 G/F	355 H/G	400 H/G	450 H/G
Electrical optionals				
Winding protection (W51 HD Safe Area)				
3-wire Pt-100, 2 per phase (alarm)	0	0	0	0
3-wire Pt-100, 2 per phase (tripping)	SD	SD	SD	SD
3-wire Pt-100, 1 per phase, calibrated (alarm)	0	0	0	0
3-wire Pt-100, 2 per phase, calibrated (alarm)	0	0	0	0
3-wire Pt-100, 2 per phase, calibrated (tripping)	0	0	0	0
PTC thermistor - 130 °C (alarm)	0	0	0	0
PTC thermistor - 155 °C (tripping)	0	0	0	0
Winding protection (W51 HD Hazardous Area)				
3-wire Pt-100, 2 per phase (alarm)	0	0	0	0
3-wire Pt-100, 2 per phase (tripping)	SD	SD	SD	SD
3-wire Pt-100, 1 per phase, calibrated (alarm)	0	0	0	0
3-wire Pt-100, 2 per phase, calibrated (alarm)	0	0	0	0
3-wire Pt-100, 2 per phase, calibrated (tripping)	0	0	0	0
Bearing thermal protection (W51 HD Safe Area)				
3-wire Pt-100 - drive end / non drive end	SD	SD	SD	SD
3-wire calibrated Pt-100 - drive end / non drive end	0	0	0	0
Two 3-wire Pt-100 - drive end / non drive end	0	0	0	0
Two 3-wire calibrated Pt-100 - drive end / non drive end	0	0	0	0
Bimetal thermal protector - drive end / non-drive end	0	0	0	0
Bearing thermal protection (W51 HD Hazardous Area)				
3-wire Pt-100 - drive end / non drive end	SD	SD	SD	SD
3-wire calibrated Pt-100 - drive end / non drive end	0	0	0	0
Two 3-wire Pt-100 - drive end / non drive end	0	0	0	0
Two 3-wire calibrated Pt-100 - drive end / non drive end	0	0	0	0
Space heaters (W51 HD Safe Area)				
110-127/220-240 V	SD	SD	SD	SD
380-480 V	0	0	0	0
Space heaters (W51 HD Hazardous Area)				
200-240 V	SD	SD	SD	SD
110-127 V	0	0	0	0
Insulation class (W51 HD Safe Area)				
F DT 80K	SD	SD	SD	SD
F DT 105K	0	0	0	0
H DT 80K (Up to 1 kV)	0	0	0	0
H DT 105K (Up to 1 kV)	0	0	0	0
Insulation class (W51 HD Hazardous Area)				
F DT 80K	SD	SD	SD	SD
Forced ventilation kit				
Forced ventilation kit prepared for encoder assembly	0	0	0	0
Forced ventilation kit do not prepared for encoder assembly	0	0	0	0
Encoder				
Without encoder	SD	SD	SD	SD
Dynapar B58N 1024	0	0	0	0
Dynapar B58N 2048	0	0	0	0
Leine&Linde XH861 900220-1024	0	0	0	0
Leine&Linde XH861 900220-2048	0	0	0	0
Grounding brush kit (W51 HD Safe Area)				
Drive end grounding brush	0	0	0	0
Drive end SGR grounding brush	0	0	0	0
Other electrical optionals				
Current transformer	0	0	0	0
Prepurge system (W51 HD Hazardous Area)	0	0	0	0

Notes:

1) Other optional features, on request.

2) Some combinations of optional features are not allowed - then contact WEG.

SD - Standard

O - Optional

15. Electrical Data

15.1 W51 HD Safe and Hazardous Area - Low Voltage

Output		Frame	Full Load Torque (Nm)	Locked Rotor Current II/In	Locked Rotor Torque TI/Tn	Breakdown Torque Tb/Tn	Inertia J (kgm ²)	Allowable locked rotor time (s)		Weight (kg)	Sound dB(A)	400 V							
								Rated speed (rpm)	% of full load						Full load current In (A)				
									Efficiency			Power Factor							
kW	HP							Hot	Cold			50	75	100	50	75	100		
II Poles																			
200	270	315G/F	641	6,9	1,0	2,4	3,20	24	53	1749	78	2980	94,9	95,7	95,8	0,81	0,87	0,89	339
220	300	315G/F	705	7,5	1,2	2,5	2,80	24	53	1640	78	2980	94,5	95,4	95,8	0,83	0,89	0,91	364
250	340	315G/F	802	6,9	1,1	2,4	4,00	20	44	1959	78	2978	95,3	95,7	95,8	0,86	0,89	0,89	423
260	350	315G/F	834	6,9	1,1	2,4	4,00	20	44	1959	78	2978	95,3	95,7	95,8	0,86	0,89	0,89	440
280	380	315G/F	899	6,9	1,1	2,4	4,00	16	35	1959	81	2977	95,4	95,7	95,8	0,85	0,90	0,90	469
300	400	315G/F	963	7,5	1,2	2,5	4,50	16	35	1920	81	2977	95,5	95,9	95,9	0,86	0,90	0,91	496
315	430	315G/F	1010	7,5	1,4	2,5	4,50	14	31	2009	81	2979	95,4	95,9	96,0	0,85	0,90	0,90	526
330	450	315G/F	1058	8,0	1,5	2,8	4,80	14	31	1970	81	2979	95,5	96,0	96,1	0,86	0,90	0,91	545
355	480	315G/F	1139	7,5	1,4	2,5	4,50	14	31	2009	81	2979	95,4	95,9	96,0	0,85	0,90	0,90	593
370	500	355H/G	1188	7,0	1,2	2,5	6,10	45	99	2650	81	2976	95,7	96,1	96,3	0,87	0,90	0,91	609
400	550	355H/G	1283	7,0	1,4	2,4	6,40	45	99	2828	81	2980	95,7	96,0	96,2	0,81	0,87	0,89	674
440	600	355H/G	1410	7,0	1,6	2,4	7,10	33	73	3078	81	2982	95,7	96,2	96,3	0,81	0,87	0,89	741
450	610	355H/G	1442	7,0	1,6	2,4	7,10	33	73	3078	81	2982	95,7	96,2	96,3	0,81	0,87	0,89	758
500	680	355H/G	1603	7,0	1,1	2,4	7,90	35	77	2998	81	2980	95,7	96,2	96,3	0,85	0,90	0,90	833
515	700	355H/G	1651	7,5	1,5	2,7	7,90	35	77	2920	81	2980	95,9	96,4	96,6	0,87	0,90	0,91	846
560	750	355H/G	1796	7,0	1,1	2,4	7,90	35	77	2998	78	2980	95,7	96,2	96,3	0,85	0,90	0,90	933
590	800	400H/G	1892	7,5	1,3	2,5	11,9	26	57	3600	78	2980	95,6	96,3	96,4	0,84	0,90	0,91	971
600	810	400H/G	1924	7,5	1,3	2,5	11,9	26	57	3600	81	2980	95,6	96,3	96,4	0,84	0,90	0,91	987
630	850	400H/G	2020	7,5	1,3	2,5	12,9	26	57	3817	81	2980	95,7	96,3	96,4	0,85	0,90	0,90	1050
660	900	400H/G	2116	7,5	1,3	2,5	12,9	26	57	3817	81	2980	95,7	96,3	96,4	0,85	0,90	0,90	1100
Optionals																			
355	480	355H/G	1140	6,8	1,0	2,4	5,70	45	99	2768	81	2976	95,5	96,0	96,1	0,85	0,90	0,90	592
560	750	400H/G	1796	7,5	1,3	2,5	11,0	26	57	3717	78	2980	95,5	96,2	96,3	0,84	0,89	0,90	933
IV Poles																			
280	380	315G/F	1798	7,1	3,0	2,6	6,00	22	48	2077	85	1488	95,6	96,0	96,0	0,76	0,84	0,87	484
300	400	315G/F	1930	6,6	2,7	2,4	6,00	20	44	2077	85	1485	95,5	95,8	96,0	0,78	0,85	0,87	518
315	430	315G/F	2023	6,9	2,8	2,5	6,50	23	51	2149	85	1488	95,9	96,2	96,0	0,77	0,85	0,87	544
330	450	315G/F	2116	7,1	2,9	2,5	6,50	17	37	2147	85	1490	95,6	95,9	96,0	0,78	0,84	0,87	570
355	480	315G/F	2280	7,3	2,8	2,6	7,10	19	42	2221	85	1488	95,9	96,2	96,0	0,76	0,84	0,87	614
370	500	315G/F	2373	7,4	3,1	2,6	7,60	16	35	2286	85	1490	95,8	96,0	96,0	0,78	0,85	0,87	639
400	550	315G/F	2567	7,8	3	2,8	8,20	18	40	2362	81	1489	96,0	96,3	96,0	0,75	0,83	0,86	699
440	600	315G/F	2837	6,0	1	2,2	8,40	31	68	2388	85	1482	96,0	96,0	96,0	0,87	0,90	0,91	727
450	610	355H/G	2882	7,1	2,6	2,9	11,4	18	40	2783	81	1492	95,9	96,5	96,4	0,70	0,79	0,83	812
480	650	355H/G	3078	7,2	2,5	2,9	11,4	14	31	2780	81	1490	95,8	96,2	96,2	0,72	0,80	0,83	868
500	680	355H/G	3204	6,9	2,8	2,8	12,3	14	31	2869	81	1491	96,2	96,5	96,3	0,73	0,81	0,85	882
515	700	355H/G	3303	6,8	2,6	2,7	12,3	13	29	2869	84	1490	96,0	96,3	96,2	0,76	0,83	0,85	909
545	740	355H/G	3490	7,8	2,8	3,2	12,8	12	26	2929	84	1492	95,5	96,1	96,2	0,68	0,77	0,82	1000
560	750	355H/G	3586	7,7	2,8	3,2	12,8	11	24	2929	84	1492	95,7	96,3	96,3	0,66	0,77	0,82	1020
590	800	355H/G	3784	6,9	1,1	2,5	13,8	46	101	3004	75	1490	96,4	96,6	96,3	0,86	0,90	0,91	972
600	810	400H/G	3848	7,0	1,5	3	20,5	30	66	3721	75	1490	96,2	96,3	96,5	0,79	0,86	0,89	1010
630	850	400H/G	4037	7,3	1,8	3,1	20,5	28	62	3711	80	1491	96,5	96,7	96,9	0,80	0,87	0,90	1040
660	900	400H/G	4232	7,0	1,7	2,9	20,5	24	53	3711	80	1490	96,5	96,6	96,8	0,81	0,88	0,90	1090
710	970	400H/G	4550	7,6	1,8	3,1	24,9	25	55	4074	80	1491	96,4	96,5	96,6	0,80	0,87	0,90	1180
750	1000	400H/G	4806	7,8	1,9	3,2	24,9	23	51	4064	80	1491	96,5	96,7	96,9	0,79	0,87	0,89	1260
800	1100	400H/G	5134	7,0	1,7	2,9	26,4	22	48	4182	80	1489	96,7	96,7	96,8	0,83	0,89	0,90	1330
850	1150	400H/G	5451	6,5	1,2	3	26,4	15	33	4173	75	1490	96,7	96,9	96,9	0,82	0,88	0,89	1420
900	1250	400H/G	5779	7,7	1,4	2,5	25,5	32	70	4252	75	1488	97,4	97,3	97,0	0,84	0,89	0,91	1470
950	1300	450H/G	6080	7,3	0,8	2,5	24,9	41	90	5104	85	1493	96,8	97,0	96,9	0,73	0,82	0,86	1650
1000	1350	450H/G	6400	7,2	0,8	2,5	26,3	41	90	5234	80	1493	96,9	97,1	96,9	0,76	0,84	0,87	1710
1100	1500	450H/G	7040	6,6	0,8	2,5	27,8	44	97	5363	80	1493	96,8	97,0	96,8	0,78	0,85	0,88	1860
Optionals																			
440	600	355H/G	2818	7,2	2,6	3,0	11,4	18	40	2783	81	1492	95,9	96,4	96,4	0,69	0,79	0,83	794
590	800	400H/G	3781	7,2	1,5	3	20,5	31	68	3721	75	1491	96,2	96,3	96,5	0,79	0,86	0,89	992
900	1250	450H/G	5756	7,7	0,8	2,5	24,9	41	90	5104	75	1494	97,0	97,5	97,5	0,71	0,81	0,86	1550

15.1 W51 HD Safe and Hazardous Area - Low Voltage

Output		Frame	Full Load Torque (Nm)	Locked Rotor Current I/In	Locked Rotor Torque TI/Tn	Breakdown Torque Tb/Tn	Inertia J (kgm²)	Allowable locked rotor time (s)		Weight (kg)	Sound dB(A)	Rated speed (rpm)	400 V						Full load current In (A)	
								Hot	Cold				% of full load			Power Factor				
													50	75	100	50	75	100		
kW	HP																			
VI Poles																				
160	220	315G/F	1547	6,1	1,9	2,2	7,50	20	44	1720	80	988	95,0	95,6	95,6	0,70	0,80	0,82	295	
185	250	315G/F	1789	6,1	1,9	2,2	8,80	16	35	1820	80	988	95,1	95,5	95,7	0,70	0,80	0,82	340	
200	270	315G/F	1934	6,3	2,2	2,3	9,50	17	37	1860	80	988	95,3	95,5	95,8	0,70	0,80	0,83	363	
220	300	315G/F	2134	6,1	1,4	2,5	10,2	17	37	1920	80	985	94,8	95,0	95,8	0,77	0,85	0,87	381	
250	340	315G/F	2425	6,5	2,3	2,4	11,4	14	31	1960	80	985	95,0	95,5	95,8	0,68	0,78	0,82	459	
260	350	315G/F	2522	6,5	2,3	2,4	11,4	14	31	1960	82	985	95,0	95,5	95,8	0,68	0,78	0,82	478	
280	380	315G/F	2716	6,5	2,3	2,4	11,4	14	31	1960	82	985	95,0	95,5	95,8	0,68	0,78	0,82	514	
300	400	355H/G	2895	4,7	1,6	2	13,6	46	101	2694	85	990	95,8	96,0	95,8	0,72	0,80	0,83	545	
315	430	355H/G	3034	5,3	1,9	2,3	13,6	38	84	2695	82	992	95,7	96,1	95,8	0,67	0,77	0,82	579	
330	450	355H/G	3179	5,1	1,7	2,2	14,8	41	90	2790	85	992	95,8	96,0	95,8	0,69	0,78	0,81	614	
355	480	355H/G	3423	5,2	2	2,2	15,9	32	70	2875	85	991	95,8	96,0	95,8	0,69	0,78	0,81	660	
370	500	355H/G	3564	5,5	2	2,4	15,9	33	73	2878	85	992	95,7	96,1	95,9	0,66	0,76	0,80	696	
400	550	355H/G	3853	5,4	2	2,3	18,3	36	79	3062	85	992	96,0	96,2	96,0	0,68	0,78	0,81	742	
440	600	355H/G	4247	6,0	0,8	2,7	19,0	135	297	3070	85	990	95,9	96,2	95,9	0,74	0,83	0,86	770	
450	610	355H/G	4343	6,0	0,8	2,7	19,0	135	297	3070	72	990	95,9	96,2	95,9	0,74	0,83	0,86	788	
480	650	400H/G	4623	6,5	1,3	2,3	24,8	16	35	3800	74	992	95,7	96,1	96,1	0,73	0,82	0,85	848	
500	680	400H/G	4816	6,5	1,3	2,3	24,8	16	35	3800	74	992	95,7	96,1	96,1	0,73	0,82	0,85	884	
515	700	400H/G	4960	6,5	1,3	2,3	26,4	16	35	3900	74	992	96,2	96,6	96,6	0,73	0,82	0,85	905	
545	740	400H/G	5249	6,0	1,4	2,3	27,9	16	35	4440	74	992	95,8	96,2	96,2	0,71	0,81	0,85	962	
560	750	400H/G	5394	6,0	1,4	2,3	27,9	16	35	4440	74	992	95,8	96,2	96,2	0,71	0,81	0,85	988	
590	800	400H/G	5683	6,0	1,4	2,3	27,9	16	35	4440	72	992	95,8	96,2	96,2	0,71	0,81	0,85	1040	
600	810	450H/G	5773	6,5	0,8	2,4	33,0	20	44	5100	72	993	96,1	96,2	96,2	0,77	0,84	0,85	1060	
630	850	450H/G	6062	6,5	0,8	2,4	33,0	20	44	5100	72	993	96,1	96,2	96,2	0,77	0,84	0,85	1110	
660	900	450H/G	6351	6,5	0,8	2,4	33,0	20	44	5200	74	993	96,5	96,6	96,6	0,77	0,84	0,87	1130	
700	950	450H/G	6736	6,5	0,8	2,4	37,4	20	44	5420	74	993	96,1	96,2	96,2	0,77	0,84	0,85	1240	
710	970	450H/G	6832	6,5	0,8	2,4	37,4	20	44	5420	74	993	96,1	96,2	96,2	0,77	0,84	0,85	1250	
750	1000	450H/G	7217	6,5	0,8	2,4	39,0	20	44	5520	74	993	96,5	96,6	96,6	0,77	0,84	0,87	1290	
800	1100	450H/G	7690	6,5	0,8	2,4	41,9	20	44	5720	74	994	96,2	96,3	96,3	0,77	0,84	0,85	1410	
850	1150	450H/G	8171	6,5	0,8	2,4	41,9	20	44	5720	76	994	96,2	96,3	96,3	0,77	0,84	0,85	1500	
900	1250	450H/G	8651	6,7	0,8	2,4	44,2	20	44	5870	74	994	96,1	96,3	96,3	0,77	0,84	0,85	1590	
Optionals																				
280	380	355H/G	2700	4,9	1,7	2,1	12,5	44	97	2600	85	991	95,8	96,0	95,8	0,72	0,80	0,83	508	
450	610	400H/G	4334	6,2	1,3	2,3	22,0	20	44	3600	72	992	95,6	96,0	96,0	0,73	0,81	0,85	796	
590	800	450H/G	5677	6,5	0,8	2,4	33,0	20	44	5100	72	993	96,1	96,2	96,2	0,77	0,84	0,85	1040	
VIII Poles																				
160	220	315G/F	2072	5,7	1,2	2,3	10,1	22	48	1850	74	738	93,9	94,5	94,5	0,68	0,78	0,82	298	
185	250	315G/F	2395	5,7	1,2	2,4	11,9	25	55	2000	74	738	94,1	94,6	94,6	0,70	0,79	0,82	344	
200	270	315G/F	2586	6,2	1,2	2,5	12,9	19	42	2100	74	739	94,3	94,8	94,8	0,68	0,78	0,82	371	
220	300	315G/F	2833	5,5	1,2	2,4	16,0	19	42	2100	74	742	94,7	95,4	95,4	0,68	0,78	0,82	406	
250	340	315G/F	3232	6,2	1,2	2,5	12,9	19	42	2100	74	739	94,3	94,8	94,8	0,68	0,78	0,82	464	
260	350	355H/G	3348	5,5	1,2	2,4	17,6	21	46	2450	70	742	94,6	95,3	95,3	0,67	0,76	0,82	480	
280	380	355H/G	3606	5,5	1,2	2,3	20,1	22	48	2820	74	742	95,0	95,5	95,4	0,70	0,78	0,82	517	
300	400	355H/G	3863	5,5	1,2	2,3	20,1	22	48	2830	74	742	95,1	95,6	95,5	0,70	0,78	0,82	553	
315	430	355H/G	4056	5,8	1,2	2,4	22,3	19	42	2980	74	742	95,1	95,5	95,5	0,68	0,77	0,82	581	
330	450	355H/G	4250	5,5	1,2	2,4	22,3	19	42	2980	74	742	95,2	95,6	95,6	0,68	0,77	0,82	608	
355	480	355H/G	4571	5,8	1,2	2,4	22,3	19	42	2980	76	742	95,1	95,5	95,5	0,68	0,77	0,82	654	
370	500	400H/G	4758	6,8	1,2	2,5	28,1	22	48	3600	76	743	94,7	95,3	95,6	0,66	0,77	0,81	690	
400	550	400H/G	5144	6,8	1,8	2,5	32,8	22	48	3600	76	743	94,6	95,3	95,6	0,66	0,77	0,81	746	
440	600	400H/G	5658	6,8	1,2	2,5	37,4	20	44	3800	68	743	94,8	95,5	95,8	0,66	0,77	0,81	818	
450	610	400H/G	5787	6,8	1,2	2,5	37,4	20	44	3800	70	743	94,8	95,5	95,8	0,66	0,77	0,81	837	
500	680	400H/G	6430	6,8	1,2	2,5	44,3	22	48	4640	70	743	95,0	95,7	96,0	0,66	0,77	0,81	928	
515	700	400H/G	6623	6,8	1,2	2,5	44,3	22	48	4640	70	743	95,0	95,7	96,0	0,66	0,77	0,81	956	
545	740	450H/G	6990	6,0	0,8	2,2	60,2	26	57	5875	70	745	95,6	96,0	96,1	0,71	0,80	0,84	974	
560	750	450H/G	7182	6,0	0,8	2,2	60,2	26	57	5875	70	745	95,6	96,0	96,1	0,71	0,80	0,84	1000	
590	800	450H/G	7577	5,9	0,8	2,2	64,6	26	57	6075	70	744	95,9	96,3	96,4	0,74	0,82	0,86	1030	
600	810	450H/G	7706	5,9	0,8	2,2	64,6	26	57	6075	73	744	95,9	96,3	96,4	0,74	0,82	0,86	1040	
630	850	450H/G	8091	6,2	0,8	2,2	64,6	26	57	6080	73	744	95,8	96,2	96,3	0,74	0,82	0,84	1120	
660	900	450H/G	8476	6,2	0,8	2,2	64,6	26	57	6080	73	744	95,8	96,2	96,3	0,74	0,82	0,84	1180	
Optionals																				
250	340	355H/G	3219	5,5	1,2	2,4	17,6	21	46	2450	74	742	94,6	95,3	95,3	0,67	0,76	0,82	462	
355	480	400H/G	4565	6,8	1,8	2,5	32,2	22	48	3600	76	743	94,6	95,2	95,5	0,66	0,77	0,81	662	
515	700	450H/G	6605	6,0	0,8	2,2	60,2	26	57	5875	70	745	95,6	96,0	96,1	0,71	0,80	0,84	921	

15.1 W51 HD Safe and Hazardous Area - Low Voltage

Output		Frame	Full Load Torque (Nm)	Locked Rotor Current I/In	Locked Rotor Torque Tl/Tn	Breakdown Torque Tb/Tn	Inertia J (kgm ²)	Allowable locked rotor time (s)		Weight (kg)	Sound dB(A)	400 V						Full load current In (A)	
								Rated speed (rpm)	% of full load										
									Efficiency			Power Factor							
kW	HP							Hot	Cold			50	75	100	50	75	100		
X Poles																			
75	100	315G/F	1215	5,5	1,5	2,0	6,90	15	33	1580	73	590	91,6	92,5	92,5	0,51	0,63	0,70	167
90	125	315G/F	1458	5,5	1,5	2	8,40	15	33	1700	70	590	91,8	92,8	92,8	0,51	0,63	0,70	200
110	150	315G/F	1781	5,5	1,5	2	10,1	15	33	1900	70	590	92,2	93,0	93,0	0,51	0,63	0,70	244
132	175	315G/F	2138	5,8	1,6	2	12,9	15	33	2100	73	590	92,6	93,2	93,2	0,51	0,63	0,70	292
150	200	315G/F	2429	5,8	1,6	2	13,8	15	33	2150	73	590	92,5	93,1	93,1	0,51	0,63	0,70	332
160	220	315G/F	2591	5,8	1,6	2	13,8	15	33	2150	73	590	92,4	93,0	93,0	0,51	0,63	0,70	355
185	250	355H/G	2991	5,5	1,2	2	20,1	20	44	2750	73	591	93,0	94,0	94,2	0,50	0,62	0,69	411
200	270	355H/G	3233	5,5	1,2	2	21,7	20	44	2820	70	591	93,2	94,2	94,4	0,50	0,62	0,69	443
220	300	355H/G	3557	5,5	1,2	2	24,8	20	44	2980	70	591	93,4	94,4	94,6	0,50	0,62	0,69	486
250	340	355H/G	4042	5,5	1,2	2	26,4	20	44	3050	70	591	93,4	94,4	94,6	0,50	0,62	0,69	553
260	350	400H/G	4189	5,5	1	2,2	26,5	22	48	3400	70	593	94,8	95,4	95,4	0,60	0,72	0,78	504
280	380	400H/G	4512	5,5	1	2,2	31,1	22	48	3545	73	593	95,0	95,6	95,6	0,60	0,72	0,78	542
315	430	400H/G	5076	5,5	1	2,2	33,5	22	48	3725	73	593	95,2	95,8	95,8	0,60	0,72	0,78	608
330	450	400H/G	5317	5,5	1	2,2	33,5	22	48	3725	68	593	95,3	95,9	95,9	0,60	0,72	0,78	637
355	480	400H/G	5720	5,5	1	2,2	38,1	22	48	3930	68	593	95,4	96,0	96,0	0,60	0,72	0,78	684
370	500	400H/G	5962	5,5	1	2,2	40,4	22	48	4100	70	593	95,5	96,1	96,1	0,60	0,72	0,78	712
400	550	400H/G	6445	5,5	1	2,2	40,4	22	48	4100	70	593	95,6	96,2	96,2	0,60	0,72	0,78	769
440	600	450H/G	7066	6,2	0,8	2,2	67,0	25	55	4770	70	595	95,4	95,8	95,8	0,60	0,72	0,79	839
450	610	450H/G	7226	6,2	0,8	2,2	67,0	25	55	4770	70	595	95,4	95,8	95,8	0,60	0,72	0,79	858
480	650	450H/G	7708	6,2	0,8	2,2	75,0	25	55	5020	73	595	95,6	96,0	96,0	0,60	0,72	0,79	914
500	680	450H/G	8029	6,2	0,8	2,2	75,0	25	55	5020	73	595	95,6	96,0	96,0	0,60	0,72	0,79	952
515	700	450H/G	8270	6,2	0,8	2,2	75,0	25	55	5020	73	595	95,7	96,1	96,1	0,60	0,72	0,79	979
560	750	450H/G	8993	6,2	0,8	2,2	80,0	25	55	5305	73	595	95,8	96,2	96,2	0,61	0,73	0,80	1050
590	800	450H/G	9475	6,2	0,8	2,2	80,0	25	55	5305	70	595	95,8	96,2	96,2	0,61	0,73	0,80	1110
Optionals																			
160	220	355H/G	2587	5,5	1,2	2,0	17,0	20	44	2350	73	591	92,8	93,8	94,0	0,50	0,62	0,69	356
250	340	400H/G	4028	5,5	1	2,2	26,5	22	48	3400	73	593	94,8	95,4	95,4	0,60	0,72	0,78	485
400	550	450H/G	6423	6,2	0,8	2,2	67,0	25	55	4770	70	595	95,4	95,8	95,8	0,60	0,72	0,79	763
XII Poles																			
132	175	355H/G	2558	4,3	1,3	1,8	18,5	20	44	2460	70	493	93,3	94,0	94,0	0,48	0,60	0,67	303
150	200	355H/G	2907	4,3	1,3	2	21,1	20	44	2520	70	493	93,3	94,0	94,0	0,48	0,60	0,67	344
160	220	355H/G	3101	4,3	1,2	1,8	24,6	20	44	3100	70	493	93,5	94,0	94,0	0,48	0,60	0,67	367
185	250	355H/G	3586	4,3	1,2	1,8	24,6	20	44	3100	72	493	93,5	94,0	94,0	0,48	0,60	0,67	424
200	270	400H/G	3853	5,5	1	2,1	33,0	20	44	3400	72	496	94,0	94,5	94,5	0,54	0,67	0,74	413
220	300	400H/G	4247	5,5	1,2	2,3	38,6	20	44	3690	72	495	94,5	94,8	94,8	0,57	0,69	0,75	447
250	340	400H/G	4826	5,5	1,2	2,3	38,6	20	44	3690	70	495	94,8	95,0	95,0	0,57	0,69	0,75	506
260	350	400H/G	5019	5,5	1,2	2,3	38,6	20	44	3690	74	495	94,8	95,0	95,0	0,57	0,69	0,75	527
280	380	400H/G	5405	5,5	1,2	2,3	41,0	20	44	4230	70	495	94,8	95,0	95,0	0,57	0,69	0,75	567
280	380	450H/G	5405	5,5	0,8	1,9	59,1	40	88	4555	70	495	94,9	95,1	95,1	0,61	0,71	0,77	552
300	400	450H/G	5791	5,5	0,8	1,9	59,1	40	88	4555	72	495	94,8	95,0	95,0	0,61	0,71	0,77	592
315	430	450H/G	6080	5,5	0,8	1,9	59,1	40	88	4555	72	495	94,9	95,1	95,1	0,61	0,71	0,77	621
330	450	450H/G	6370	5,5	0,8	1,9	67,6	40	88	4790	72	495	95,0	95,2	95,2	0,61	0,71	0,77	650
355	480	450H/G	6853	5,5	0,8	1,9	67,6	40	88	4790	72	495	95,1	95,3	95,3	0,61	0,71	0,77	698
400	550	450H/G	7721	5,5	0,8	1,9	72,0	40	88	5050	70	495	95,3	95,5	95,5	0,61	0,71	0,77	785
440	600	450H/G	8493	5,5	0,8	1,9	76,2	40	88	5310	70	495	95,5	95,7	95,7	0,62	0,72	0,78	851
450	610	450H/G	8686	5,5	0,8	1,9	76,2	40	88	5310	70	495	95,5	95,7	95,7	0,62	0,72	0,78	870
480	650	450H/G	9265	5,5	0,8	1,9	80,5	40	88	5620	70	495	95,7	95,9	95,9	0,62	0,72	0,78	926
500	680	450H/G	9651	5,5	0,8	1,9	80,5	40	88	5620	70	495	95,7	95,9	95,9	0,62	0,72	0,78	965
515	700	450H/G	9940	5,5	0,8	1,9	80,5	40	88	5620	70	495	95,7	95,9	95,9	0,62	0,72	0,78	994
Optionals																			
185	250	400H/G	3564	5,5	1,0	2,1	33,0	20	44	3400	72	496	94,0	94,5	94,5	0,54	0,67	0,74	382

15.2 W51 HD Safe and Hazardous Area - High Voltage 1,2 kV to 5,0 kV

Output		Frame	Full Load Torque (Nm)	Locked Rotor Current I/In	Locked Rotor Torque Tl/Tn	Breakdown Torque Tb/Tn	Inertia J (kgm²)	Allowable locked rotor time (s)		Weight (kg)	Sound dB(A)	3300 V							Full load current In (A)
								Rated speed (rpm)	% of full load										
									Efficiency			Power Factor							
kW	HP							Hot	Cold			50	75	100	50	75	100		
II Poles																			
250	340	315G/F	802	7,0	1,2	2,4	2,50	20	44	1907	78	2980	95,0	95,5	95,4	0,75	0,83	0,86	53,3
280	380	315G/F	898	6,8	1,1	2,3	2,60	20	44	1950	78	2978	95,4	95,7	95,6	0,78	0,85	0,88	58,2
300	400	315G/F	963	6,5	1	2,2	2,90	20	44	2030	78	2977	95,6	95,9	95,7	0,83	0,87	0,89	61,6
315	430	315G/F	1011	6,5	1,1	2,2	3,10	20	44	2064	78	2978	95,7	95,9	95,7	0,83	0,87	0,89	64,7
330	450	315G/F	1058	7,2	1,2	2,4	3,10	20	44	2070	81	2980	95,7	96,1	95,9	0,80	0,86	0,88	68,4
355	480	315G/F	1139	7,2	1,1	2,4	3,40	20	44	2137	81	2979	95,9	96,2	96,0	0,82	0,87	0,89	72,7
370	500	315G/F	1187	7,0	1,1	2,3	3,40	20	44	2137	81	2978	95,9	96,2	96,0	0,82	0,87	0,89	75,8
400	550	315G/F	1280	6,8	0,8	2,2	5,10	20	44	2242	81	2987	96,2	96,5	96,3	0,84	0,88	0,89	81,7
440	600	355H/G	1413	7,2	1,1	2,5	5,20	18	40	2651	81	2975	95,8	96,3	96,3	0,83	0,88	0,90	88,8
450	610	355H/G	1447	6,8	1	2,5	5,70	18	40	2741	81	2972	95,9	96,3	96,3	0,86	0,90	0,91	89,8
500	680	355H/G	1607	6,8	1	2,5	6,10	18	40	2825	81	2972	95,7	96,2	96,2	0,87	0,90	0,91	100
560	750	355H/G	1796	6,5	0,8	2,2	7,30	18	40	2868	81	2980	95,8	96,4	96,5	0,85	0,90	0,91	112
590	800	400H/G	1889	7,2	0,8	2,5	8,70	18	40	3743	81	2984	96,3	96,8	96,9	0,86	0,90	0,91	117
630	850	400H/G	2018	7,0	0,8	2,5	9,30	18	40	3856	81	2983	96,5	96,9	96,9	0,86	0,90	0,91	125
660	900	400H/G	2113	7,5	0,8	2,5	9,30	18	40	3858	78	2984	96,5	97,0	97,0	0,85	0,89	0,91	131
710	970	400H/G	2273	7,5	0,8	2,5	9,80	18	40	3976	78	2984	96,6	97,1	97,1	0,86	0,90	0,91	141
750	1000	400H/G	2402	7,2	0,8	2,5	9,80	18	40	3976	78	2983	96,4	96,9	97,0	0,86	0,90	0,92	147
800	1100	400H/G	2563	7,2	1,1	2,5	13,6	18	40	4066	81	2982	95,9	96,2	96,1	0,83	0,88	0,89	164
900	1250	450H/G	2885	6,5	0,8	2,3	23,2	20	44	5034	81	2981	96,4	96,5	96,3	0,88	0,90	0,90	182
1000	1350	450H/G	3202	7,5	0,9	2,5	24,6	20	44	5179	81	2984	96,4	96,6	96,4	0,86	0,90	0,90	202
1100	1500	450H/G	3523	7,0	0,9	2,5	27,4	20	44	5459	81	2983	95,6	96,1	96,0	0,87	0,90	0,90	223
Optional																			
400	550	355H/G	1285	7,2	1,1	2,5	4,60	18	40	2586	81	2975	95,6	96,1	96,1	0,83	0,88	0,90	80,9
560	750	400H/G	1793	7,4	0,9	2,5	8,70	18	40	3743	81	2984	96,2	96,8	96,9	0,85	0,89	0,91	111
800	1100	450H/G	2564	6,8	0,8	2,4	21,9	20	44	4887	81	2981	96,1	96,3	96,1	0,87	0,90	0,90	162
IV Poles																			
220	270	315G/F	1415	6,8	1,3	2,5	3,80	20	44	1888	81	1486	93,9	94,7	94,8	0,67	0,77	0,82	49,5
250	340	315G/F	1605	6,8	1,3	2,5	4,10	20	44	1925	81	1488	94,2	95,0	95,1	0,65	0,76	0,81	56,8
280	380	315G/F	1802	6,5	1,3	2,5	4,30	20	44	1966	81	1485	94,4	95,1	95,0	0,68	0,78	0,83	62,1
315	430	315G/F	2023	7,0	1,4	2,5	4,60	20	44	2011	81	1488	94,5	95,3	95,4	0,63	0,75	0,80	72,2
355	480	315G/F	2281	6,5	1,2	2,5	5,20	20	44	2108	81	1487	95,0	95,6	95,5	0,69	0,79	0,83	78,4
400	550	315G/F	2572	6,0	1,2	2,4	5,70	20	44	2179	81	1486	95,2	95,7	95,6	0,71	0,80	0,84	87,1
440	600	315G/F	2822	6,8	1,2	2,5	8,70	20	44	2411	81	1490	95,7	96,2	96,1	0,78	0,85	0,87	92,1
450	610	355H/G	2888	6,8	1,8	2,5	9,20	20	44	2768	81	1489	95,4	96,0	96,1	0,72	0,81	0,84	97,5
500	680	355H/G	3209	6,8	1,9	2,5	9,70	20	44	2862	81	1489	95,6	96,2	96,3	0,67	0,77	0,82	111
560	750	355H/G	3594	6,8	1,8	2,5	11,1	20	44	3023	84	1489	95,6	96,2	96,3	0,70	0,79	0,83	123
590	800	355H/G	3786	7,0	1,2	2,5	14,3	20	44	3105	84	1489	96,0	96,5	96,5	0,71	0,80	0,84	127
630	850	400H/G	4035	6,5	1,1	2,5	16,8	20	44	3704	75	1492	96,1	96,7	96,8	0,68	0,78	0,82	139
660	900	400H/G	4230	6,0	1	2,5	16,9	20	44	3724	75	1491	96,2	96,7	96,8	0,73	0,81	0,84	142
710	970	400H/G	4547	6,8	1,2	2,5	17,9	20	44	3838	75	1492	96,2	96,8	96,9	0,65	0,76	0,81	158
750	1000	400H/G	4806	6,2	1	2,5	19,1	20	44	3955	80	1491	96,4	96,9	97,0	0,70	0,79	0,83	163
800	1100	400H/G	5123	7,2	1,3	2,5	21,5	20	44	4169	80	1492	95,7	96,2	96,2	0,66	0,76	0,81	180
900	1250	400H/G	5775	6,2	1	2,5	27,3	20	44	4315	80	1489	96,2	96,4	96,1	0,77	0,84	0,86	191
1000	1350	450H/G	6400	6,8	0,9	2,5	26,4	20	44	5340	80	1493	96,5	96,8	96,6	0,73	0,81	0,85	213
1100	1500	450H/G	7040	6,8	0,8	2,5	27,8	20	44	5483	75	1493	96,6	96,8	96,7	0,73	0,81	0,85	234
1250	1700	450H/G	8000	6,8	0,9	2,5	27,8	20	44	5502	75	1493	96,2	96,6	96,5	0,71	0,80	0,84	270
Optional																			
440	600	355H/G	2823	7,0	1,8	2,5	9,20	20	44	2768	81	1489	95,3	96,0	96,1	0,72	0,80	0,84	95,4
590	800	400H/G	3781	6,0	1	2,5	15,6	20	44	3604	84	1491	96,2	96,7	96,7	0,71	0,79	0,83	129
900	1250	450H/G	5760	7,2	0,9	2,5	23,5	20	44	5046	80	1493	96,2	96,6	96,5	0,68	0,78	0,82	199

15.2 W51 HD Safe and Hazardous Area - High Voltage 1,2 kV to 5,0 kV

Output		Frame	Full Load Torque (Nm)	Locked Rotor Current I _L /I _n	Locked Rotor Torque T _L /T _n	Breakdown Torque T _b /T _n	Inertia J (kgm ²)	Allowable locked rotor time (s)		Weight (kg)	Sound dB(A)	Rated speed (rpm)	3300 V						Full load current I _n (A)
								Hot	Cold				% of full load			Power Factor			
													50	75	100	50	75	100	
kW	HP																		
VI Poles																			
220	270	315G/F	2134	5,5	1,4	2,1	5,50	25	55	2129	75	985	94,3	94,7	94,4	0,64	0,74	0,79	51,6
250	340	315G/F	2425	5,5	1,5	2,2	6,00	25	55	2197	80	985	94,5	94,9	94,6	0,63	0,74	0,79	58,5
260	350	315G/F	2522	5,5	1,4	2,1	6,00	25	55	2197	74	985	94,6	94,9	94,6	0,65	0,75	0,79	60,9
280	380	315G/F	2719	5,5	1,4	2,1	6,40	25	55	2271	80	984	94,8	95,0	94,7	0,66	0,75	0,79	65,5
300	400	315G/F	2904	6,0	1,6	2,4	6,90	25	55	2338	80	987	94,6	95,1	95,0	0,60	0,71	0,77	71,8
315	430	315G/F	3040	5,8	1,4	2,3	8,60	25	55	2384	80	990	95,1	95,5	95,3	0,68	0,77	0,81	71,4
330	450	355H/G	3185	6,2	1,6	2,3	12,3	25	55	2760	80	990	94,8	95,4	95,3	0,63	0,74	0,78	77,7
355	480	355H/G	3423	6,8	1,7	2,5	13,2	25	55	2839	80	991	94,7	95,4	95,4	0,60	0,71	0,77	84,6
370	500	355H/G	3571	6,0	1,5	2,3	14,2	25	55	2927	82	990	95,0	95,5	95,4	0,64	0,74	0,79	85,9
400	550	355H/G	3861	6,0	1,5	2,3	14,2	25	55	2936	82	990	95,1	95,6	95,5	0,64	0,74	0,79	92,8
440	600	355H/G	4230	7,0	1,2	2,5	18,8	25	55	3086	82	994	95,2	95,8	95,8	0,67	0,77	0,82	98,0
450	610	355H/G	4330	6,8	1,2	2,5	18,8	25	55	3086	82	993	95,3	95,9	95,8	0,68	0,78	0,82	100
500	680	400H/G	4806	7,0	1,3	2,5	23,6	25	55	3789	82	994	95,3	95,8	95,7	0,64	0,76	0,80	114
560	750	400H/G	5383	7,0	1,3	2,5	25,1	25	55	3902	85	994	95,4	95,9	95,8	0,64	0,75	0,80	128
590	800	400H/G	5666	7,5	1,4	2,5	25,1	25	55	3913	85	995	95,3	95,9	95,8	0,59	0,71	0,77	140
630	850	400H/G	6056	6,8	1,2	2,5	26,7	25	55	4027	85	994	95,5	96,0	95,8	0,65	0,76	0,81	142
660	900	400H/G	6351	6,8	1	2,4	36,4	25	55	4294	85	993	95,3	95,8	95,7	0,72	0,81	0,85	142
710	970	450H/G	6825	6,5	1	2,5	37,1	25	55	5019	72	994	95,8	96,2	96,1	0,72	0,81	0,84	154
750	1000	450H/G	7202	7,1	1,1	2,5	39,3	25	55	5147	74	995	95,7	96,2	96,1	0,70	0,79	0,83	165
800	1100	450H/G	7690	6,3	0,9	2,5	41,6	25	55	5294	74	994	96,0	96,3	96,2	0,74	0,82	0,85	171
900	1250	450H/G	8651	6,6	1	2,5	43,8	25	55	5432	74	994	96,0	96,3	96,2	0,73	0,81	0,84	195
1000	1350	450H/G	9613	6,4	0,9	2,5	46,1	25	55	5584	74	994	95,8	96,2	96,1	0,74	0,82	0,85	214
Optionals																			
315	430	355H/G	3034	6,8	1,8	2,5	11,4	25	55	2672	80	992	94,5	95,2	95,3	0,58	0,70	0,76	76,1
450	610	400H/G	4326	6,8	1,2	2,5	22,0	25	55	3681	82	994	95,4	95,8	95,6	0,67	0,77	0,82	100
660	900	450H/G	6344	6,6	1	2,5	32,5	25	55	4721	72	994	95,7	96,1	96,0	0,70	0,79	0,83	145
VIII Poles																			
132	180	315G/F	1707	5,5	1,2	2,3	8,40	15	33	1780	74	739	92,3	93,1	93,3	0,57	0,69	0,76	32,6
160	220	315G/F	2069	5,5	1,2	2,3	10,1	15	33	1900	72	739	92,5	93,5	93,6	0,57	0,69	0,76	39,4
185	250	315G/F	2392	5,7	1,2	2,5	11,9	12	26	2040	72	739	92,7	93,5	93,7	0,57	0,69	0,76	45,5
200	270	315G/F	2586	5,7	1,7	2,5	17,0	12	26	2110	72	739	92,9	93,5	93,7	0,59	0,71	0,77	48,5
220	300	315G/F	2845	5,7	1,7	2,5	17,0	12	26	2110	72	739	92,9	93,5	93,7	0,59	0,71	0,77	53,3
250	340	355H/G	3224	6,0	1,7	2,2	18,5	22	48	2830	74	741	94,4	95,0	94,7	0,62	0,72	0,78	59,2
280	380	355H/G	3611	6,0	1,3	2,2	20,1	22	48	2900	74	741	94,5	95,1	94,9	0,62	0,72	0,78	66,2
315	430	355H/G	4067	6,2	1,4	2,3	23,2	22	48	3050	74	740	94,6	95,2	95,1	0,60	0,71	0,77	75,3
355	480	355H/G	4584	6,2	1,4	2,3	23,2	22	48	3050	74	740	94,6	95,2	95,1	0,60	0,71	0,77	84,8
400	550	400H/G	5151	6,0	1,1	2,3	35,4	22	48	3785	74	742	94,8	95,5	95,6	0,70	0,80	0,82	89,3
450	610	400H/G	5795	6,0	1	2,5	40,2	22	48	4440	74	742	94,9	95,6	95,7	0,69	0,79	0,82	100
500	680	400H/G	6430	6,0	1	2,5	40,2	22	48	4640	74	743	94,9	95,4	95,7	0,66	0,76	0,81	113
560	750	400H/G	7202	6,0	1	2,5	33,0	22	48	4790	74	743	95,1	95,6	95,7	0,66	0,77	0,81	126
630	850	450H/G	8091	5,5	0,9	2,3	58,0	30	66	5573	74	744	95,6	96,1	96,1	0,69	0,79	0,83	138
710	970	450H/G	9106	5,5	0,9	2,3	48,2	30	66	5725	74	745	95,6	96,1	96,1	0,69	0,79	0,83	156
800	1100	450H/G	10260	5,5	0,9	2,3	48,2	28	62	6100	74	745	95,8	96,2	96,2	0,69	0,79	0,83	175
900	1250	450H/G	11540	5,5	0,9	2,3	48,2	28	62	6100	74	745	95,8	96,2	96,2	0,69	0,79	0,83	197
Optionals																			
220	300	355H/G	2837	6,0	1,3	2,2	17,0	22	48	2640	74	741	94,2	94,8	94,5	0,62	0,72	0,78	52,2
355	480	400H/G	4571	6,0	1,1	2,3	33,0	22	48	3655	74	742	94,8	95,3	95,4	0,70	0,80	0,82	79,4
560	750	450H/G	7182	5,5	0,9	2,3	54,7	30	66	5275	74	745	95,4	96,0	96,1	0,68	0,78	0,82	124

15.2 W51 HD Safe and Hazardous Area - High Voltage 1,2 kV to 5,0 kV

Output		Frame	Full Load Torque (Nm)	Locked Rotor Current I _L /I _n	Locked Rotor Torque T _L /T _n	Breakdown Torque T _b /T _n	Inertia J (kgm ²)	Allowable locked rotor time (s)		Weight (kg)	Sound dB(A)	Rated speed (rpm)	3300 V						Full load current I _n (A)
								Hot	Cold				% of full load			Power Factor			
													50	75	100	50	75	100	
kW	HP																		
X Poles																			
150	200	355H/G	2425	5,5	1,2	2,2	20,1	11	24	2535	74	591	91,3	92,6	92,9	0,43	0,55	0,63	44,8
160	220	355H/G	2587	5,5	1,2	2,2	20,1	11	24	2670	74	591	91,5	92,8	93,1	0,44	0,56	0,64	47,0
185	250	355H/G	2991	5,5	1,2	2,2	21,7	11	24	2805	74	591	91,7	93,0	93,3	0,44	0,56	0,64	54,2
200	270	355H/G	3233	5,5	1,2	2,2	23,2	11	24	2975	76	591	91,9	93,2	93,5	0,44	0,56	0,64	58,5
220	300	355H/G	3551	5,6	1,3	2,2	23,2	11	24	2975	76	592	91,1	93,2	93,5	0,44	0,56	0,64	64,3
250	340	400H/G	4028	5,5	0,9	2	28,2	28	62	3065	76	593	94,1	94,6	94,6	0,58	0,69	0,74	62,5
280	380	400H/G	4512	5,5	0,9	2	33,0	28	62	3215	68	593	94,3	94,8	94,8	0,59	0,70	0,75	68,9
315	430	400H/G	5076	5,5	0,9	2	37,8	28	62	3385	70	593	94,5	95,0	95,0	0,59	0,70	0,75	77,3
355	480	400H/G	5720	5,5	0,9	2	40,2	28	62	3580	70	593	94,7	95,2	95,2	0,60	0,71	0,76	85,8
400	550	400H/G	6434	5,6	0,9	2,1	40,2	28	62	3580	70	594	94,8	95,2	95,2	0,60	0,71	0,76	96,7
450	610	450H/G	7239	5,5	0,9	2	79,4	31	68	5500	70	594	95,2	95,6	95,6	0,66	0,76	0,80	103
500	680	450H/G	8043	5,5	0,9	2	79,4	31	68	5725	70	594	95,4	95,8	95,8	0,66	0,76	0,80	114
560	750	450H/G	9008	5,5	0,9	2	85,3	31	68	5520	70	594	95,6	96,0	96,0	0,66	0,76	0,80	128
Optionals																			
220	300	400H/G	3545	5,5	0,9	2,0	25,8	28	62	2935	76	593	93,9	94,4	94,4	0,58	0,69	0,74	55,1
400	550	450H/G	6434	5,5	0,9	2	48,2	31	68	4715	70	594	95,0	95,4	95,4	0,66	0,76	0,80	91,7
XII Poles																			
160	220	400H/G	3088	5,5	1,1	2,3	30,6	25	55	5940	73	495	92,3	93,5	93,7	0,51	0,64	0,71	42,1
185	250	400H/G	3571	5,5	1,1	2,3	33,0	25	55	3060	73	495	92,5	93,7	93,9	0,51	0,64	0,71	48,5
200	270	400H/G	3861	5,5	1,1	2,3	33,0	25	55	3210	73	495	92,7	93,9	94,1	0,51	0,64	0,71	52,4
220	300	400H/G	4247	5,5	1,1	2,3	35,4	25	55	3365	73	495	92,9	94,1	94,3	0,51	0,64	0,71	57,5
250	340	400H/G	4816	5,6	1,2	2,4	35,4	25	55	3365	70	496	92,1	94,1	94,3	0,51	0,64	0,71	65,3
280	380	450H/G	5416	5,5	1	2	51,4	50	110	4815	73	494	94,6	95,1	95,1	0,48	0,60	0,67	76,9
315	430	450H/G	6093	5,5	1	2	54,7	50	110	5085	73	494	94,8	95,3	95,3	0,48	0,60	0,67	86,3
355	480	450H/G	6866	5,5	1	2	58,0	50	110	5385	73	494	95,0	95,5	95,5	0,48	0,60	0,67	97,1
400	550	450H/G	7706	6,5	0,7	2,4	57,9	30	66	6740	73	496	94,1	94,7	94,7	0,50	0,63	0,70	106
Optionals																			
250	340	450H/G	4835	5,5	1,0	2,0	48,2	50	110	4580	70	494	94,4	94,9	94,9	0,48	0,60	0,67	68,8

15.3 W51 HD Safe and Hazardous Area - High Voltage 5,1 kV to 6,6 kV

Output		Frame	Full Load Torque (Nm)	Locked Rotor Current II/In	Locked Rotor Torque TI/Tn	Breakdown Torque Tb/Tn	Inertia J (kgm ²)	Allowable locked rotor time (s)		Weight (kg)	Sound dB(A)	Rated speed (rpm)	6600 V						Full load current In (A)
								Hot	Cold				% of full load			Power Factor			
													50	75	100	50	75	100	
kW	HP																		
II Poles																			
220	300	315G/F	705	6,8	1,1	2,4	2,50	18	40	1894	80	2980	94,5	95,0	94,8	0,78	0,84	0,87	23,3
250	340	315G/F	802	6,8	1,1	2,3	2,80	17	37	1977	78	2980	95,0	95,4	95,2	0,80	0,86	0,88	26,1
280	380	315G/F	899	6,4	1	2,1	2,80	17	37	1977	81	2977	95,3	95,5	95,1	0,82	0,87	0,89	28,9
315	430	315G/F	1011	6,2	1	2	3,40	18	40	2123	81	2976	95,6	95,7	95,3	0,85	0,89	0,90	32,1
355	480	315G/F	1139	6,8	1,1	2,3	3,40	14	31	2123	81	2979	95,6	95,8	95,6	0,82	0,87	0,89	36,5
370	500	315G/F	1187	6,8	1,3	2,5	4,80	20	44	2193	81	2979	95,3	95,8	95,7	0,77	0,84	0,87	38,9
400	550	355H/G	1286	6,8	1	2,5	5,70	16	35	2703	81	2973	95,6	96,0	95,9	0,85	0,90	0,91	40,1
440	600	355H/G	1414	6,8	1	2,5	6,10	16	35	2788	81	2973	95,7	96,1	96,0	0,86	0,90	0,91	44,1
450	610	355H/G	1447	6,6	1	2,4	6,10	16	35	2788	81	2972	95,4	95,9	95,8	0,86	0,90	0,91	45,2
500	680	355H/G	1604	7,0	0,9	2,4	7,30	18	40	2839	81	2979	96,0	96,4	96,2	0,86	0,90	0,90	50,5
530	710	355H/G	1701	6,6	0,8	2,3	7,30	18	40	2839	81	2978	95,7	96,1	96,0	0,87	0,90	0,90	53,7
560	750	400H/G	1794	6,6	0,7	2,5	8,70	21	46	3704	81	2982	96,1	96,5	96,5	0,86	0,90	0,91	55,8
590	800	400H/G	1891	6,2	0,7	2,5	8,70	21	46	3711	84	2981	96,3	96,6	96,6	0,87	0,90	0,91	58,7
630	850	400H/G	2018	6,8	0,7	2,5	9,30	19	42	3810	84	2983	96,3	96,7	96,6	0,86	0,90	0,91	62,7
660	900	400H/G	2115	6,6	0,7	2,5	9,30	19	42	3831	84	2982	96,1	96,6	96,6	0,87	0,90	0,91	65,7
710	970	400H/G	2276	6,4	0,9	2,3	12,8	18	40	3914	84	2981	96,4	96,8	96,7	0,84	0,88	0,89	72,2
750	1000	400H/G	2403	6,8	1	2,4	12,8	15	33	3915	84	2982	96,4	96,8	96,8	0,82	0,87	0,89	76,2
800	1100	400H/G	2563	6,6	1	2,4	13,6	16	35	4048	84	2982	95,8	96,1	95,9	0,82	0,87	0,88	82,9
900	1250	450H/G	2883	6,8	0,8	2,5	24,6	18	40	5129	86	2983	96,2	96,4	96,1	0,87	0,90	0,90	91,0
1000	1350	450H/G	3204	6,8	0,8	2,4	26,0	17	37	5273	86	2982	96,3	96,4	96,1	0,87	0,90	0,90	101
1100	1500	450H/G	3525	7,0	0,9	2,5	27,4	16	35	5419	86	2982	95,4	95,9	95,7	0,87	0,90	0,90	112
Optionals																			
370	500	355H/G	1189	6,6	1,0	2,4	5,00	17	37	2576	81	2973	95,4	95,9	95,8	0,85	0,89	0,90	37,5
530	710	400H/G	1699	6,4	0,7	2,5	8,70	24	53	3697	81	2981	96,1	96,5	96,4	0,87	0,90	0,91	52,9
800	1100	450H/G	2564	6,2	0,7	2,2	23,2	22	48	4997	86	2981	96,1	96,3	96,0	0,88	0,90	0,90	81,0
IV Poles																			
220	300	315G/F	1413	6,8	1,3	2,5	4,10	30	66	1915	82	1488	93,7	94,5	94,5	0,65	0,76	0,82	24,8
250	340	315G/F	1605	6,6	1,2	2,5	4,10	27	59	1924	75	1488	94,0	94,8	94,7	0,65	0,76	0,82	28,2
280	380	315G/F	1798	6,6	1,2	2,5	4,60	26	57	2004	80	1488	94,3	95,0	95,0	0,65	0,77	0,82	31,4
315	430	315G/F	2025	6,8	1,3	2,5	5,20	23	51	2111	80	1486	94,4	95,1	95,1	0,66	0,77	0,82	35,3
355	480	315G/F	2286	6,2	1,2	2,5	5,20	23	51	2111	80	1484	94,8	95,3	95,1	0,69	0,79	0,83	39,3
370	500	315G/F	2379	7,0	1,4	2,5	6,10	22	48	2243	80	1486	94,6	95,3	95,4	0,66	0,77	0,82	41,4
400	550	315G/F	2563	7,4	1,2	2,5	8,70	19	42	2381	80	1491	95,1	95,7	95,6	0,76	0,84	0,84	43,6
440	600	355H/G	2822	7,2	1,9	2,5	9,70	20	44	2828	75	1490	95,2	95,9	96,0	0,66	0,76	0,82	48,9
450	610	355H/G	2886	7,0	1,8	2,5	9,70	20	44	2828	80	1490	95,2	95,9	96,0	0,67	0,77	0,82	50,0
500	680	355H/G	3206	7,2	1,9	2,5	10,4	18	40	2921	80	1490	95,3	96,0	96,1	0,65	0,76	0,82	55,5
560	750	355H/G	3591	7,4	2	2,5	11,1	16	35	3006	80	1490	95,1	95,9	96,1	0,63	0,74	0,82	62,2
590	800	355H/G	3784	7,4	1,2	2,5	14,4	24	53	3096	80	1490	95,7	96,3	96,3	0,69	0,79	0,84	63,8
630	850	400H/G	4032	7,2	1,2	2,5	16,8	19	42	3701	80	1493	95,8	96,5	96,7	0,63	0,74	0,82	69,5
660	900	400H/G	4224	7,2	1,3	2,5	17,9	19	42	3816	82	1493	95,9	96,6	96,8	0,63	0,75	0,82	72,7
710	970	400H/G	4544	7,2	1,2	2,5	19,1	19	42	3930	82	1493	96,0	96,7	96,8	0,63	0,75	0,82	78,2
750	1000	400H/G	4803	6,6	1,1	2,5	20,3	21	46	4046	82	1492	96,2	96,8	96,9	0,69	0,78	0,83	81,6
800	1100	400H/G	5123	7,2	1,3	2,5	21,5	19	42	4135	82	1492	95,6	96,0	96,0	0,66	0,76	0,83	87,8
850	1150	400H/G	5447	7,4	1,2	2,5	27,1	18	40	4284	82	1491	95,6	96,0	96,0	0,67	0,77	0,83	93,3
900	1250	450H/G	5756	7,4	1	2,5	24,9	22	48	5142	85	1494	95,9	96,4	96,4	0,65	0,76	0,83	98,4
1000	1350	450H/G	6400	7,4	1	2,5	26,3	21	46	5334	85	1493	96,1	96,6	96,5	0,66	0,76	0,83	109
1100	1500	450H/G	7040	7,2	1	2,5	29,3	21	46	5585	85	1493	96,4	96,7	96,6	0,73	0,82	0,85	117
1150	1550	450H/G	7360	7,2	0,9	2,5	29,2	21	46	5595	85	1493	95,9	96,4	96,3	0,71	0,80	0,84	124
Optionals																			
400	550	355H/G	2565	7,0	1,8	2,5	9,10	21	46	2747	75	1490	95,1	95,8	95,9	0,66	0,77	0,83	44,0
590	800	400H/G	3778	6,8	1,1	2,5	16,8	22	48	3684	80	1492	95,8	96,5	96,6	0,66	0,77	0,82	65,2
850	1150	450H/G	5440	7,4	1	2,5	23,5	23	51	5007	85	1493	95,9	96,3	96,3	0,65	0,76	0,83	93,0

15.3 W51 HD Safe and Hazardous Area - High Voltage 5,1 kV to 6,6 kV

Output		Frame	Full Load Torque (Nm)	Locked Rotor Current I/In	Locked Rotor Torque Tl/Tn	Breakdown Torque Tb/Tn	Inertia J (kgm ²)	Allowable locked rotor time (s)		Weight (kg)	Sound dB(A)	Rated speed (rpm)	6600 V						Full load current In (A)
								Hot	Cold				% of full load			Power Factor			
													Efficiency		Power Factor				
kW	HP	50	75	100	50	75	100												
VI Poles																			
200	270	315G/F	1938	5,6	1,5	2,2	6,00	20	44	2186	72	986	93,7	94,2	94,0	0,63	0,74	0,78	23,9
220	300	315G/F	2130	6,0	1,6	2,4	6,40	20	44	2252	74	987	93,6	94,3	94,2	0,60	0,72	0,78	26,2
250	340	315G/F	2423	5,8	1,6	2,3	6,40	20	44	2255	74	986	93,9	94,4	94,3	0,61	0,72	0,78	29,7
280	380	315G/F	2697	7,5	1,9	2,5	8,00	20	44	2307	74	992	94,0	94,9	95,0	0,56	0,69	0,78	33,1
300	400	355H/G	2893	6,2	1,5	2,3	13,2	20	44	2814	72	991	94,4	94,9	94,8	0,64	0,74	0,79	35,0
315	430	355H/G	3034	7,2	1,9	2,5	14,2	20	44	2896	74	992	93,9	94,8	94,9	0,57	0,69	0,78	37,2
330	450	355H/G	3179	7,0	1,8	2,5	14,2	20	44	2911	74	992	94,2	95,0	95,1	0,58	0,70	0,78	38,9
355	480	355H/G	3423	6,6	1,7	2,5	14,2	20	44	2911	74	991	94,5	95,2	95,2	0,61	0,72	0,78	41,8
370	500	355H/G	3571	6,2	1,5	2,3	15,1	20	44	2998	74	990	94,8	95,3	95,2	0,64	0,74	0,79	43,0
400	550	355H/G	3845	7,4	1,3	2,5	18,8	20	44	3061	74	994	94,6	95,3	95,4	0,64	0,75	0,81	45,3
440	600	400H/G	4230	7,0	1,2	2,5	22,0	20	44	3665	74	994	95,1	95,5	95,4	0,64	0,75	0,80	50,4
450	610	400H/G	4326	6,8	1,2	2,5	22,0	20	44	3665	74	994	95,1	95,6	95,4	0,65	0,76	0,81	50,9
500	680	400H/G	4801	7,2	1,3	2,5	23,6	20	44	3772	74	995	95,0	95,6	95,5	0,61	0,73	0,80	57,2
560	750	400H/G	5383	7,2	1,3	2,5	25,1	20	44	3897	74	994	95,2	95,7	95,6	0,63	0,74	0,80	64,1
590	800	400H/G	5671	6,6	1,1	2,5	26,7	20	44	4010	74	994	95,5	95,8	95,6	0,67	0,77	0,82	65,8
630	850	400H/G	6062	7,5	1,4	2,5	34,5	20	44	4156	74	993	95,2	95,6	95,5	0,72	0,81	0,84	68,7
660	900	450H/G	6338	7,0	1	2,5	34,8	20	44	4819	76	995	95,4	95,9	95,8	0,68	0,78	0,83	72,6
710	970	450H/G	6825	6,6	0,9	2,5	37,1	20	44	4972	76	994	95,6	96,0	95,9	0,71	0,80	0,84	77,1
750	1000	450H/G	7202	7,2	1	2,5	39,3	20	44	5099	76	995	95,5	96,0	95,9	0,68	0,78	0,83	82,4
800	1100	450H/G	7682	7,2	1	2,5	41,6	20	44	5244	76	995	95,6	96,0	96,0	0,68	0,78	0,83	87,8
900	1250	450H/G	8643	7,5	1,1	2,5	43,8	20	44	5393	76	995	95,1	95,8	95,8	0,65	0,76	0,83	99,0
Optionals																			
280	380	355H/G	2697	7,0	1,8	2,5	12,3	20	44	2728	72	992	93,9	94,7	94,7	0,58	0,70	0,78	33,2
400	550	400H/G	3841	7,2	1,2	2,5	20,5	20	44	3540	74	995	94,8	95,3	95,3	0,62	0,74	0,79	46,5
630	850	450H/G	6050	6,8	1	2,5	32,5	20	44	4683	76	995	95,4	95,8	95,8	0,68	0,78	0,83	69,3
VIII Poles																			
160	220	355H/G	2063	5,6	1,2	2,2	10,9	20	44	2260	70	741	93,0	93,4	93,5	0,60	0,71	0,77	19,4
185	250	355H/G	2386	5,6	1,2	2,2	12,3	20	44	2540	70	741	93,4	93,8	93,9	0,61	0,72	0,78	22,1
200	270	355H/G	2579	5,6	1,2	2,2	14,1	20	44	2670	70	741	93,5	93,9	94,0	0,61	0,72	0,78	23,9
220	300	355H/G	2837	5,6	1,2	2,2	16,4	20	44	2820	70	741	93,7	94,1	94,2	0,61	0,72	0,78	26,2
250	340	355H/G	3224	5,8	1,3	2,5	17,5	15	33	2900	70	741	93,8	94,2	94,3	0,57	0,69	0,75	30,9
280	380	355H/G	3611	5,8	1,3	2,5	18,4	15	33	2980	70	741	93,9	94,3	94,4	0,55	0,67	0,74	35,1
315	430	400H/G	4067	6,0	1,1	2,3	35,0	19	42	3700	70	740	94,7	94,8	94,8	0,70	0,79	0,82	35,4
355	480	400H/G	4584	6,0	1	2,3	37,4	19	42	4330	70	740	94,9	95,0	95,0	0,67	0,76	0,81	40,4
400	550	400H/G	5165	6,0	1	2,3	39,7	19	42	4440	70	740	94,9	95,0	95,0	0,67	0,76	0,81	45,5
450	610	400H/G	5810	6,0	1	2,3	44,3	19	42	4640	70	740	95,1	95,4	95,4	0,67	0,77	0,81	50,9
500	680	400H/G	6456	6,6	1	2,4	47,5	19	42	4790	70	740	95,2	95,6	95,6	0,66	0,76	0,80	57,2
560	750	450H/G	7182	5,5	0,9	2,3	54,8	30	66	5725	73	745	95,2	95,7	95,7	0,70	0,79	0,83	61,7
630	850	450H/G	8080	5,5	0,9	2,3	60,0	30	66	5900	73	745	95,3	95,9	95,9	0,70	0,79	0,83	69,2
710	970	450H/G	9106	5,8	1	2,4	65,4	22	48	6085	73	745	95,5	96,0	96,0	0,67	0,77	0,81	79,9
Optionals																			
280	380	400H/G	3615	6,0	1,1	2,3	30,4	19	42	3500	70	740	94,5	94,6	94,6	0,70	0,79	0,82	31,6
500	680	450H/G	6413	5,5	0,9	2,3	54,8	30	66	5575	73	745	95,2	95,6	95,6	0,70	0,79	0,83	55,1



16. Mechanical Data

16.1 Frames 315G/F to 450H/G

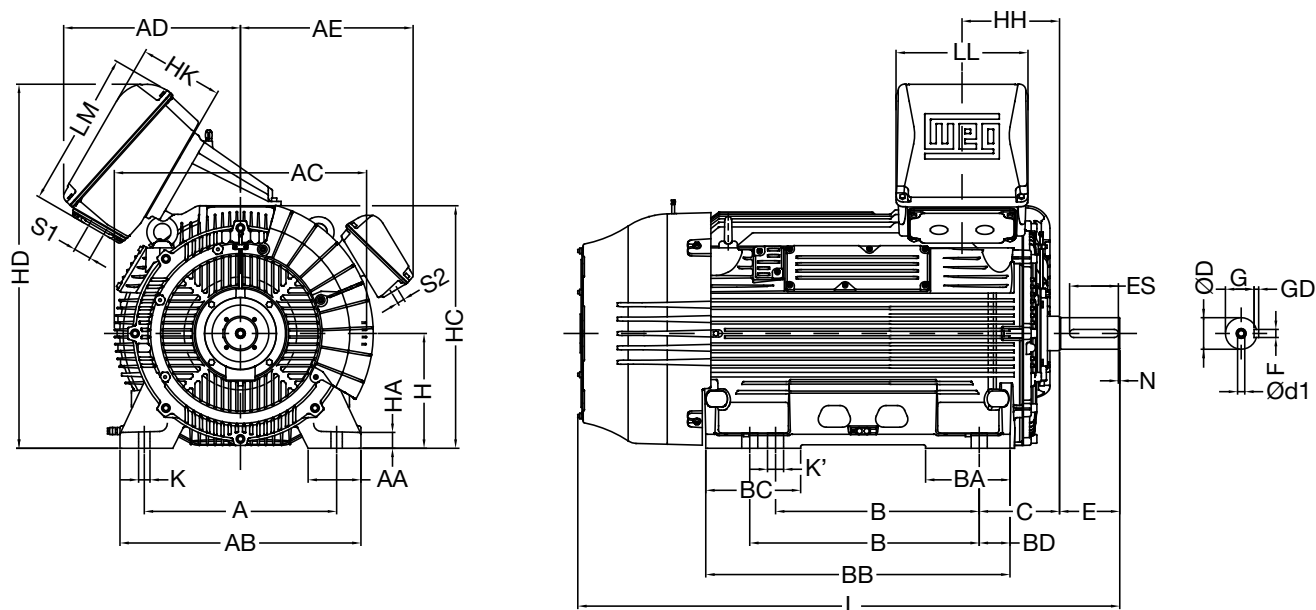

Frame	N° poles	A	AA	AB	AC	AD	AE	B	BA	BB	BC	BD	C	Shaft End						
														D	E	ES	N	F	G	GD
315 G/F	2	508	132	650	729	619 ¹	566	800/900	308	1173	390	84	216	65	140	125	5	18	58	11
	4 to 12													90	170	140		25	81	14
355 H/G	2	610	160	765	800		594	900/1000	320	1235	429	89	254	65	140	125		18	58	11
	4 to 12													100	210	170		28	90	16
400 H/G	2	686	180	840	890		655	1000/1120	445	1390	442	121	280	80	170	160		22	71	14
	4 to 12													110	210	200		28	100	16
450 H/G	2	750	225	940	968		680	1120/1250	478	1580	542	143	315	85	170	160	22	76	14	
	4 to 12													130	250	200	32	119	18	

Frame	N° poles	H	HA	HC	HD	HH	HK	K	K'	L	LL	LM	d1	S1'	S2	Bearing			
																DE	NDE		
315 G/F	2	315	50	660	1104	321	290	28	38	1833	460	544 ¹	M20x2,5	2xM63x1.5	3xM20x1.5	6314 C3	6314 C3		
	4 to 12												M24x3			6320 C3	6316 C3		
355 H/G	2	355		765	1190	349		1975	48	2045	2145	2185	2374	2454	M20x2,5	2xM80x2.0	3xM20x1.5	6314 C3	6314 C3
	4 to 12																	M24x3	6322 C3
400 H/G	2	400		852	1277	340		2185	36	56	2374	2454	M20x2,5	M24x3	2xM80x2.0	3xM20x1.5	6220 C3	6220 C3	
	4 to 12																M24x3	6324 C3	6319 C3
450 H/G	2	450		962	1387	350		2374	36	56	2374	2454	M20x2,5	M24x3	2xM80x2.0	3xM20x1.5	6220 C3	6220 C3	
	4 to 12																M24x3	6328 M-C3	6322 C3

1) For motors with voltage 1.2 kV and above the dimension AD will be 663 mm, dimension LM will be 730 mm and dimension S1 will be M63x1.5.

2) Dimensions in mm.

16.2 “FF” Flange

Dimensions in mm.

Frame	Flange	C	M	N	P	S	T	N° holes
315G/F	FF-600	216	600	550	660	24	6	8
355H/G	FF-740	254	740	680	800			
400H/G	FF-940	280	940	880	1000	28	6	8
450H/G	FF-1080	315	1080	1000	1150			

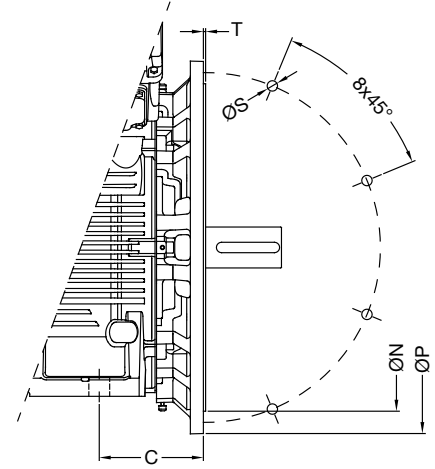

16.3 External Motor Dimensions with Steel Plate Terminal Box

Dimensions in mm.

Frame	Designation			
	Steel 1 and Steel 2		Steel 11	
	AD	HD	AD	HD
315G/F	889	1230	864	1240
355H/G		1320		1330
400H/G		1415		1425
450H/G		1512		1522

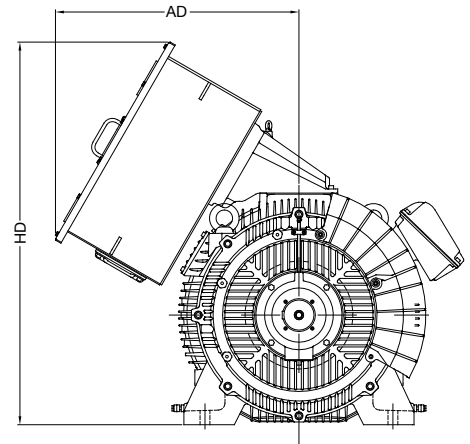

16.4 External Motor Dimensions with Sleeve Bearing

Dimensions in mm.

Frame	N° poles	C	LB
315G/F	2	375	2128
	4 - 8		2158
355H/G	2	425	2263
	4 - 8		2283
400H/G	2	450	2467
	4 - 8		2507
450H/G	2	475	2680
	4 - 8		2760

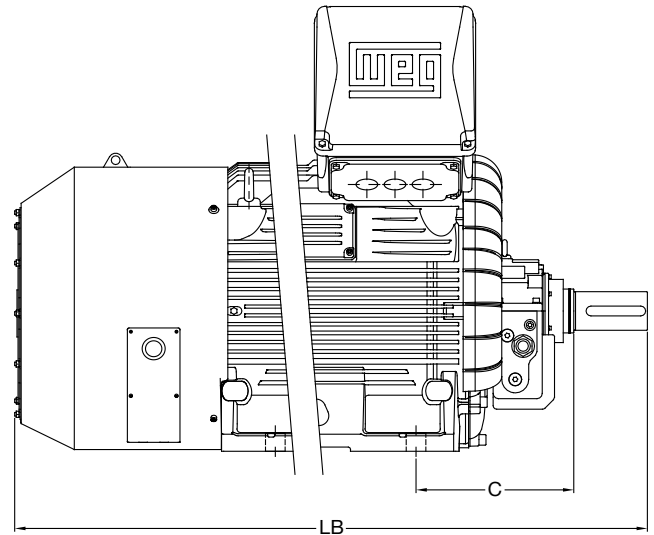

16.5 External Motor Dimensions with Forced Ventilation

Dimensions in mm.

Frame	N° poles	LC
315G/F	2	1997
	4 - 8	2027
355H/G	2	2138
	4 - 8	2208
400H/G	2	2307
	4 - 8	2347
450H/G	2	2537
	4 - 8	2617

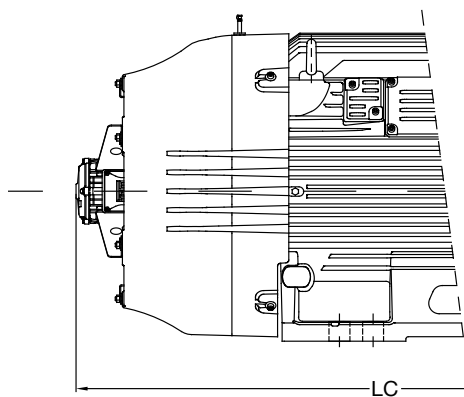

16.6 Drip Cover Height

Dimensions in mm.

Frame	CH (mm)
315G/F	91
355H/G	
400H/G	119
450H/G	

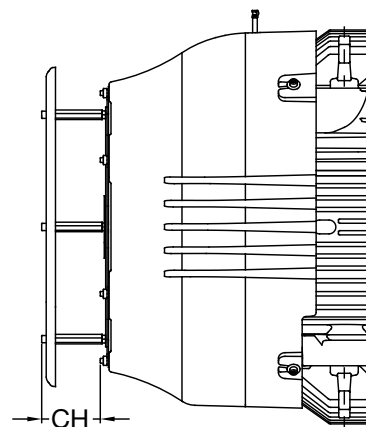

17. Terminal Boxes

The terminal boxes can be manufactured in cast iron FC-200 or in steel plate. Below see the external dimensionals and some technical features.

17.1 Cast Iron Terminal Boxes

17.1.1 Iron 01

Dimensions in mm.

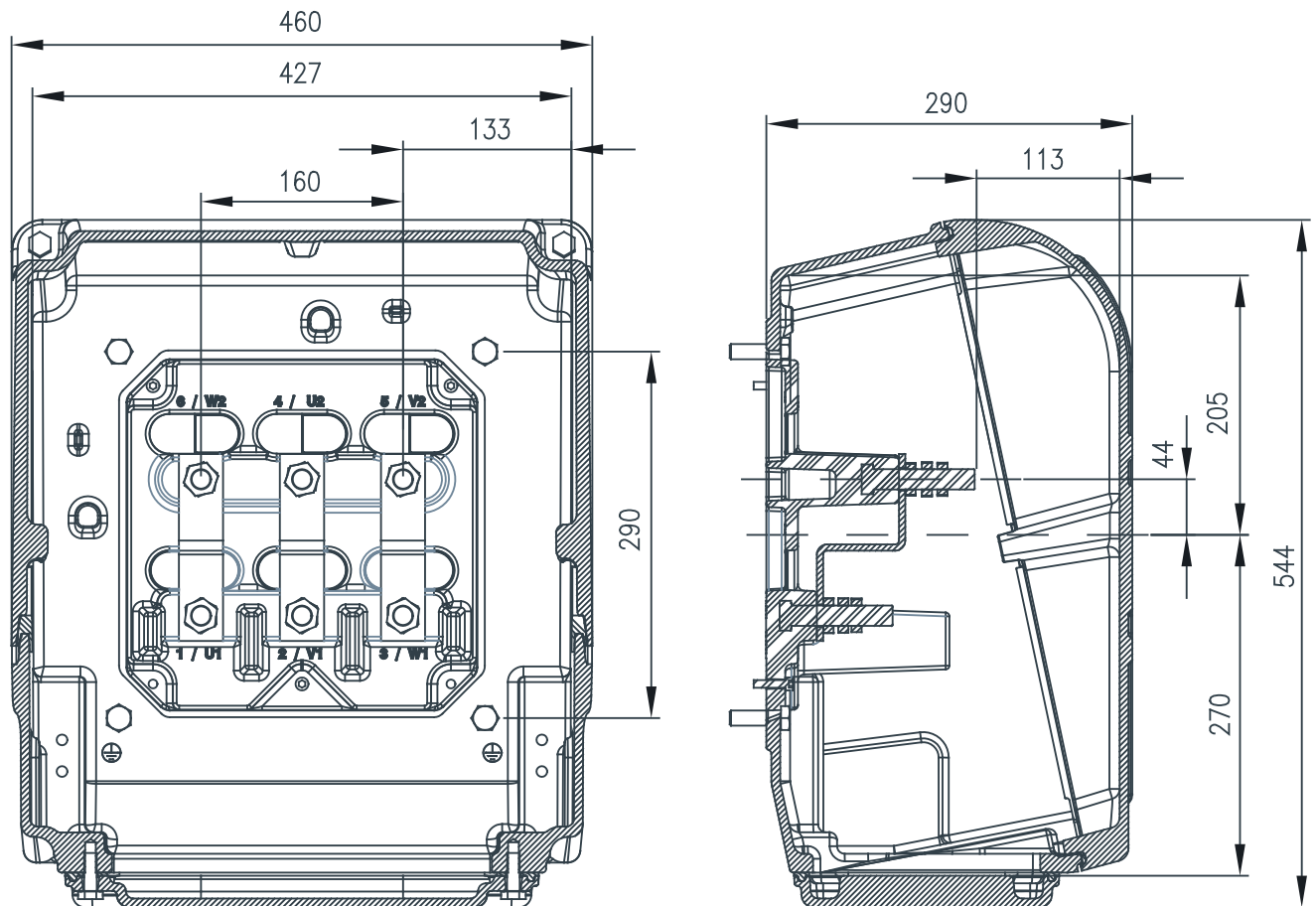

Technical data	
Maximum quantity of leads	1 per phase
Entry plates for leads designation	Type 01
Internal volume	51 dm ³
Connecting bolt	M16 x 2
Tightening torque of the terminals	30 Nm
Grounding terminal	Internal
Approximate weight	75 kg
Degree of protection	IP66
General data	
Minimum terminal box thickness	7 mm
Rotate in steps of 90°	Yes

17.1.2 Cast Iron 02

Dimensions in mm.

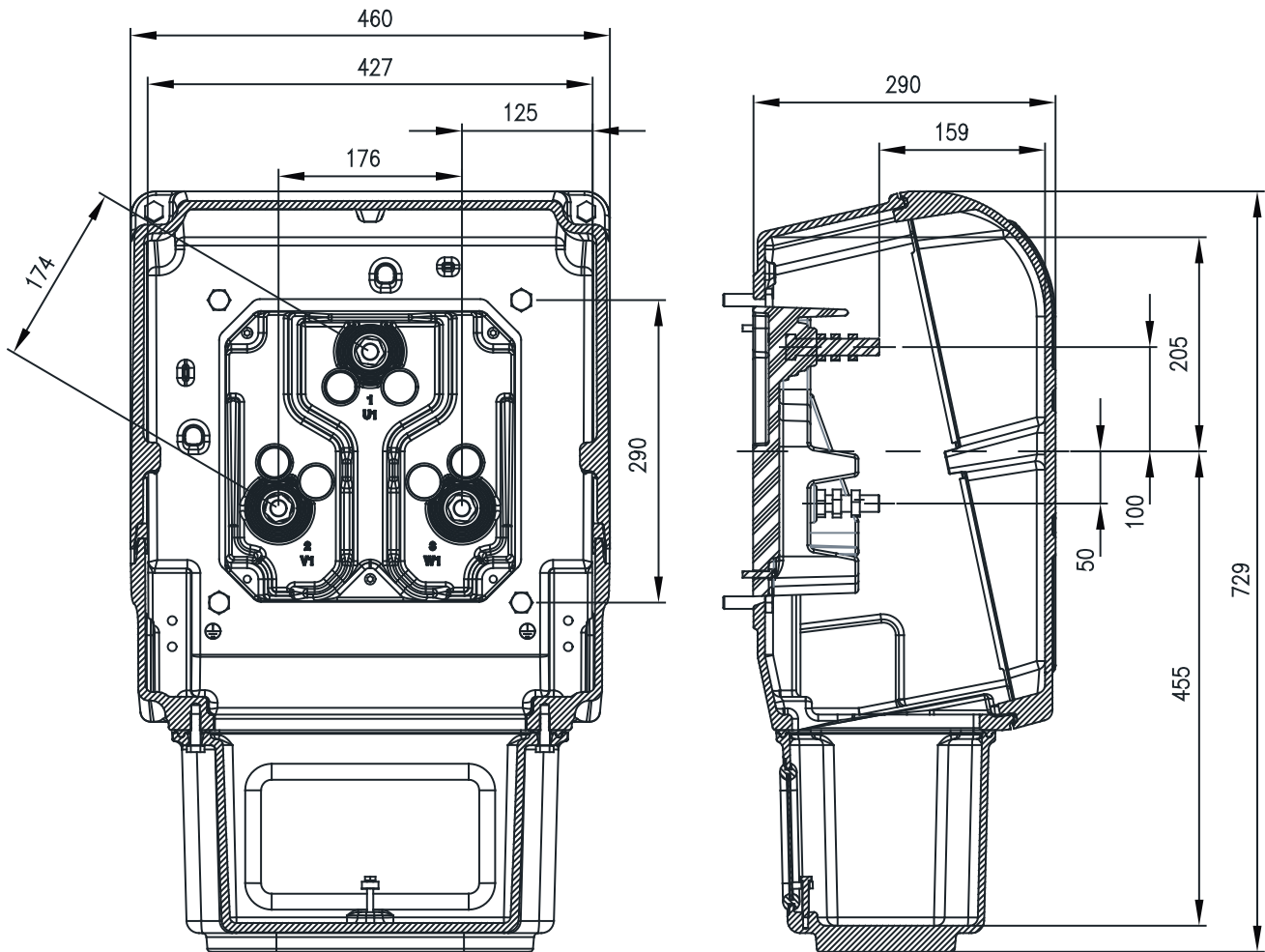

Technical data	
Maximum quantity of leads	1 per phase
Entry plates for leads designation	Type 02
Internal volume	64,7 dm ³
Connecting bolt	M16 x 2
Tightening torque of the terminals	30 Nm
Grounding terminal	Internal
Approximate weight	75 kg
Degree of protection	IP66
General data	
Minimum terminal box thickness	7 mm
Rotate in steps of 90°	
Pressure relief device in the back of the terminal box in case of short circuit	Yes

17.1.3 Cast Iron 05

Dimensions in mm.

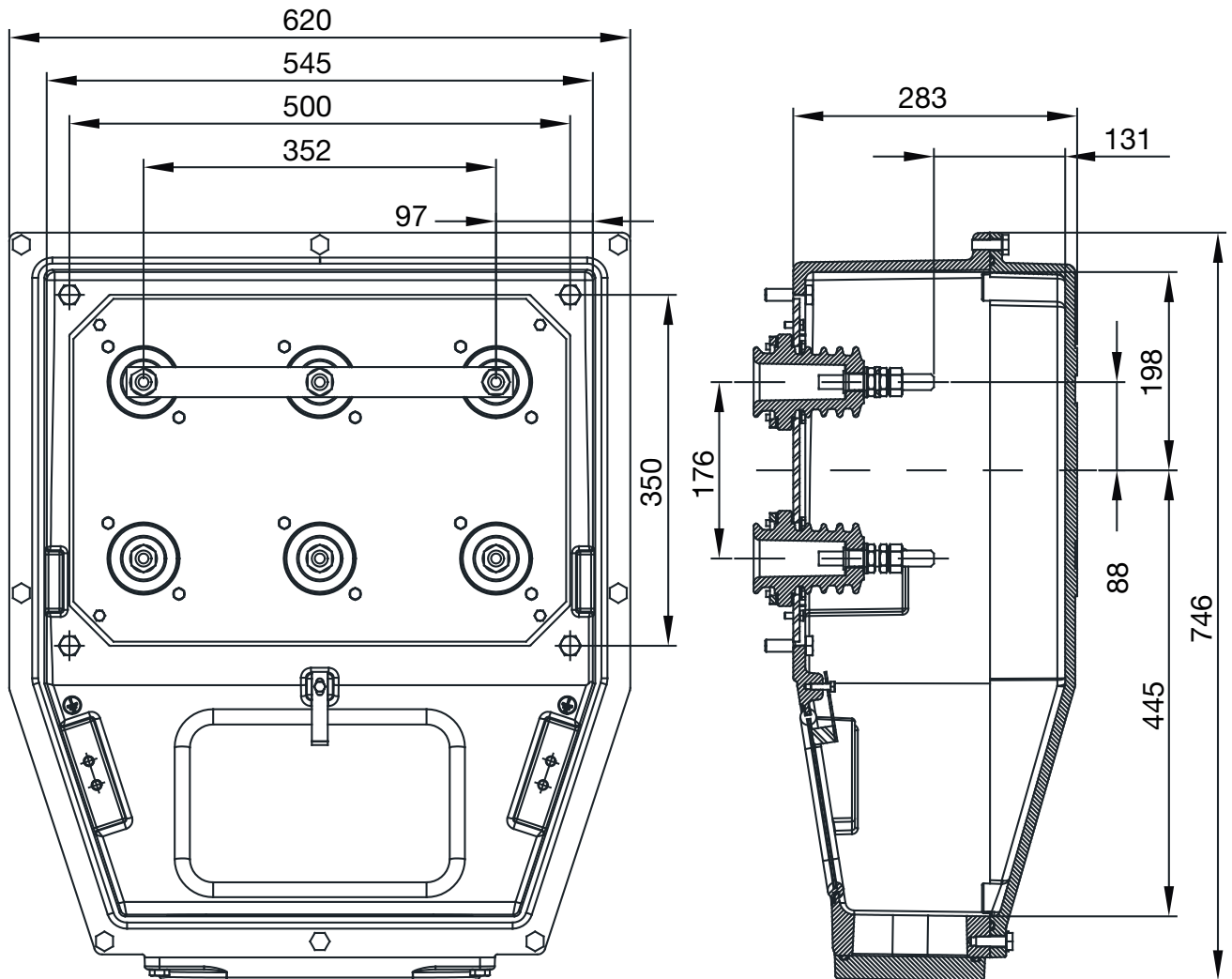

Technical data	
Maximum quantity of leads	2 per phase
Entry plates for leads designation	Type 03
Internal volume	81.2 dm ³
Grounding terminal	Internal
Approximate weight	120 kg
Degree of protection	IP66
General data	
Minimum terminal box thickness	8 mm
Rotate in steps of 90°	Yes
Pressure relief device in the back of the terminal box in case of short circuit	

17.2 Steel Plate Terminal Boxes

17.2.1 Steel 01

Dimensions in mm.

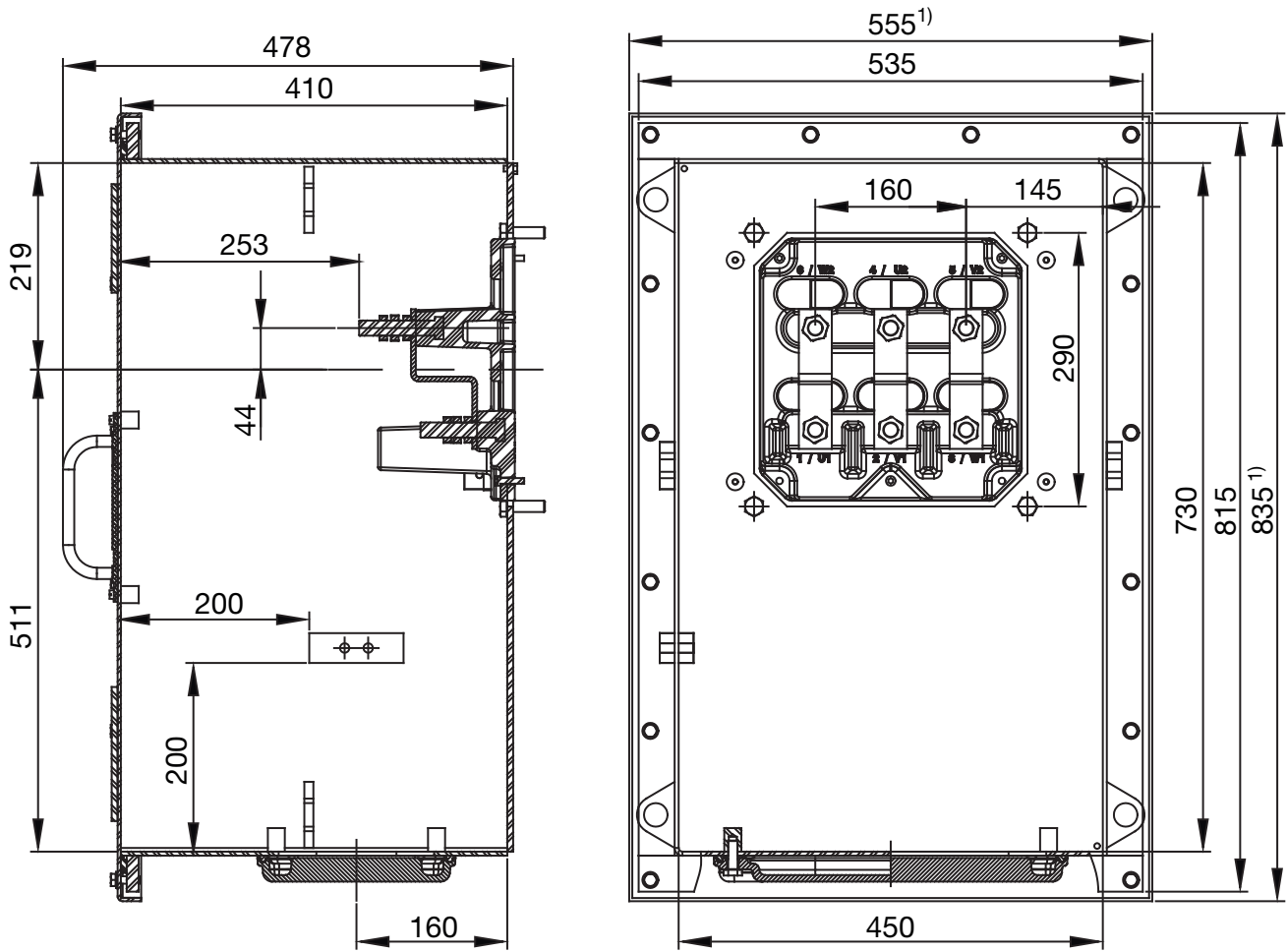

1) Cover dimension.

Technical data	
Maximum quantity of leads	1 per phase
Entry plates for leads designation	Type 01
Internal volume	131,4 dm ³
Connecting bolt	M16 x 2
Tightening torque of the terminals	30 Nm
Grounding terminal	Internal or external
Approximate weight	95 kg
Degree of protection	IP66
General data	
Minimum terminal box thickness	3,35 mm
Rotate in steps of 90°	Yes
Eyebolts	4 eyebolts

17.2.2 Steel 02

Dimensions in mm.

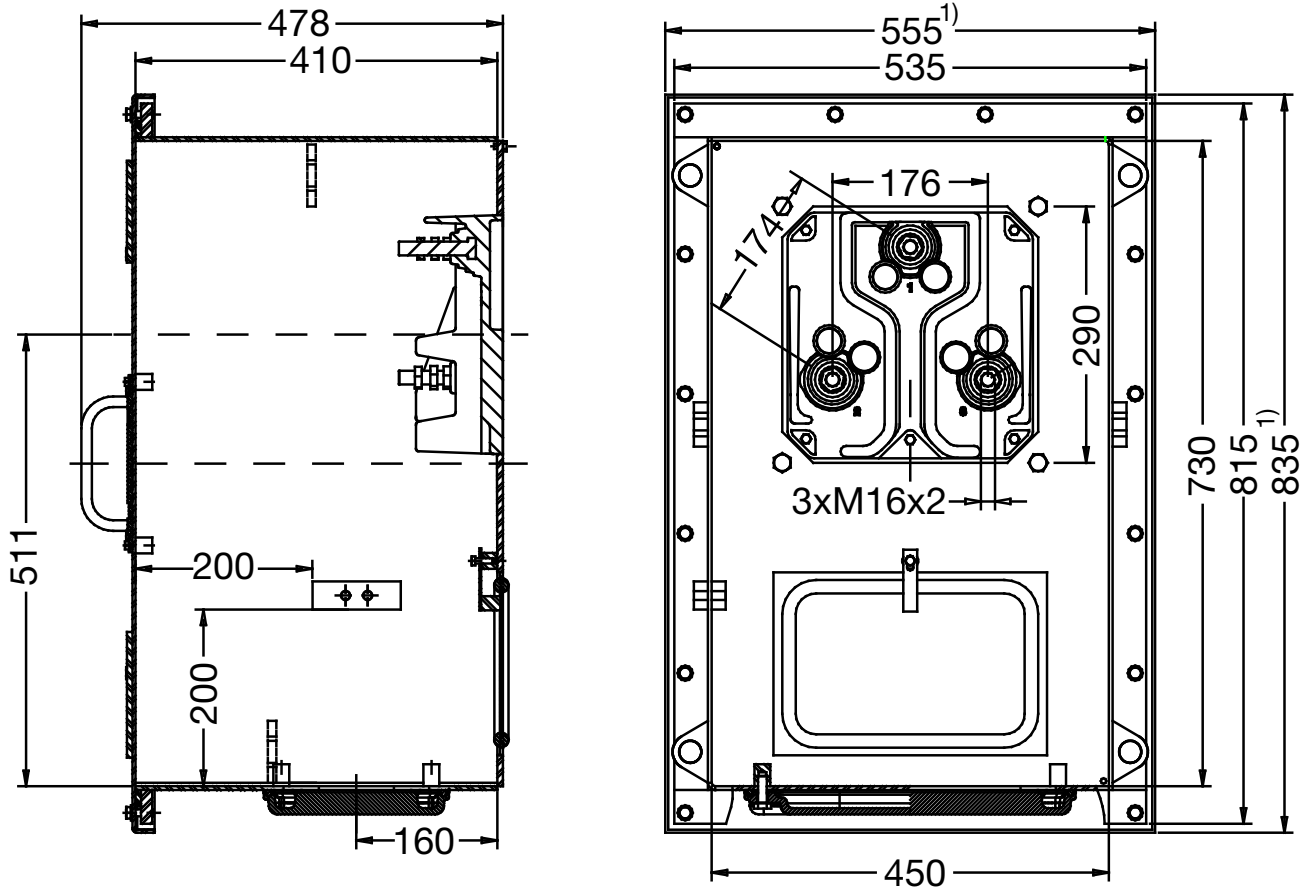

1) Cover dimension.

Technical data	
Maximum quantity of leads	1 per phase
Entry plates for leads designation	Type 01
Internal volume	134,7 dm ³
Connecting bolt	M16 x 2
Tightening torque of the terminals	30 Nm
Grounding terminal	Internal or external
Approximate weight	90 kg
Degree of protection	IP66
General data	
Minimum terminal box thickness	3,35 mm
Rotate in steps of 90°	Yes
Eyebolts	4 eyebolts
Pressure relief device in the back of the terminal box in case of short circuit	Yes

17.2.3 Steel 04

Dimensions in mm.

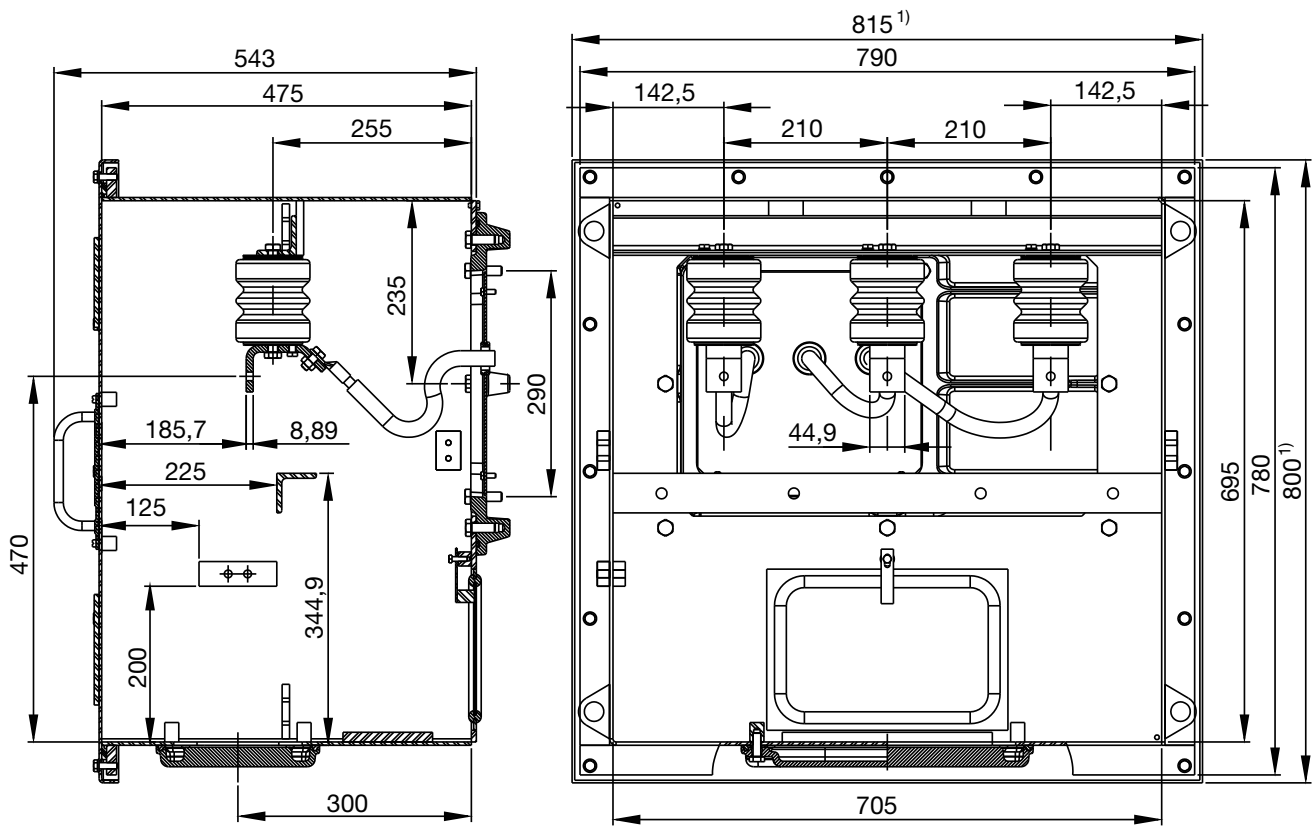

1) Cover dimension.

Technical data	
Maximum quantity of leads	1 per phase
Entry plates for leads designation	Type 01
Internal volume	232 dm ³
Grounding terminal	Internal or external
Approximate weight	135 kg
Degree of protection	IP66
General data	
Minimum terminal box thickness	3.35 mm
Eyebolts	4 eyebolts
Rotate in steps of 90°	
Pressure relief device in the back of the terminal box in case of short circuit	Yes

17.2.4 Steel 06

Dimensions in mm.

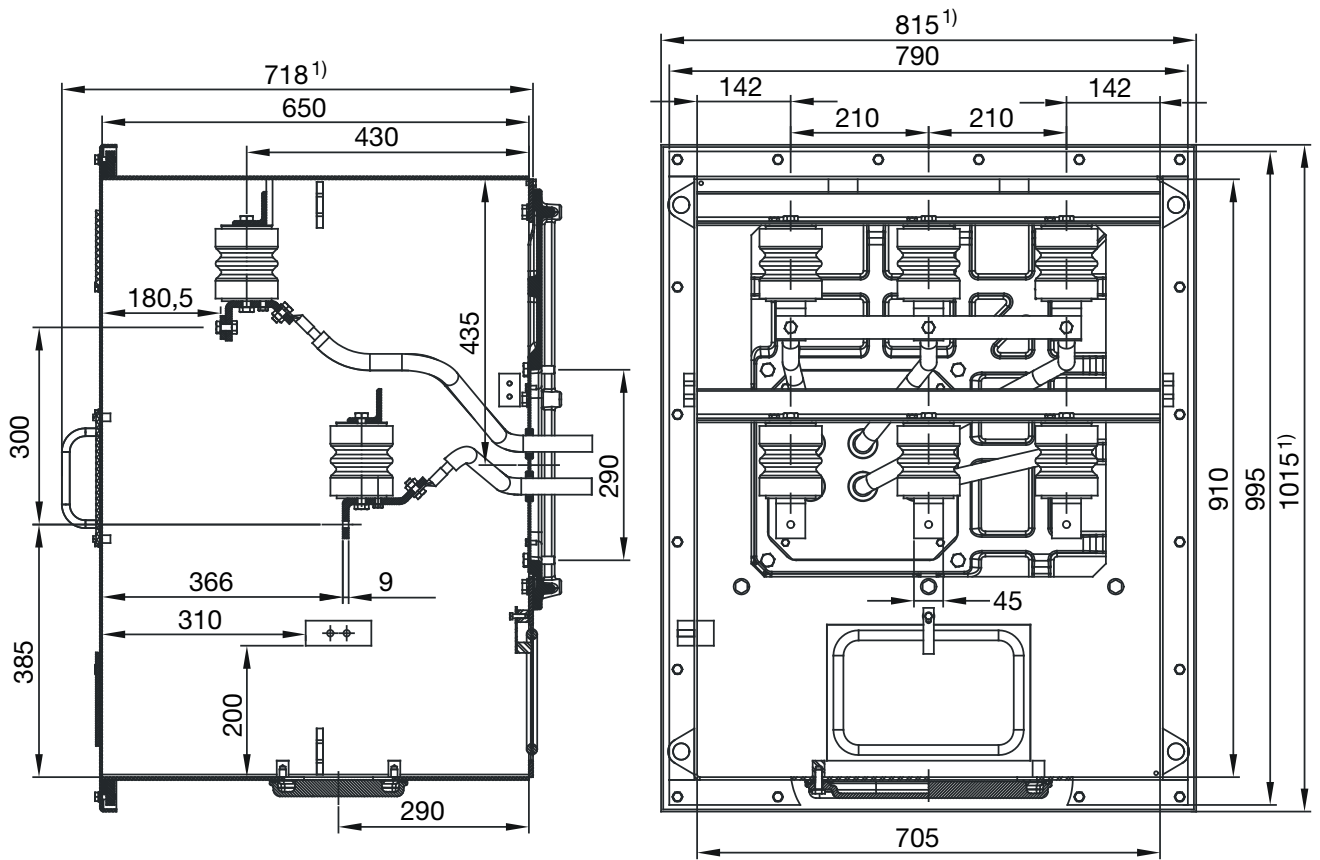

1) Cover dimension.

Technical data	
Maximum quantity of leads	2 per phase
Entry plates for leads designation	Type 01
Internal volume	417 dm ³
Grounding terminal	Internal or external
Approximate weight	195 kg
Degree of protection	IP66
General data	
Minimum terminal box thickness	3,35 mm
Eyebolts	4 eyebolts
Rotate in steps of 90°	Yes
Pressure relief device in the back of the terminal box in case of short circuit	

17.2.5 Steel 08

Dimensions in mm.

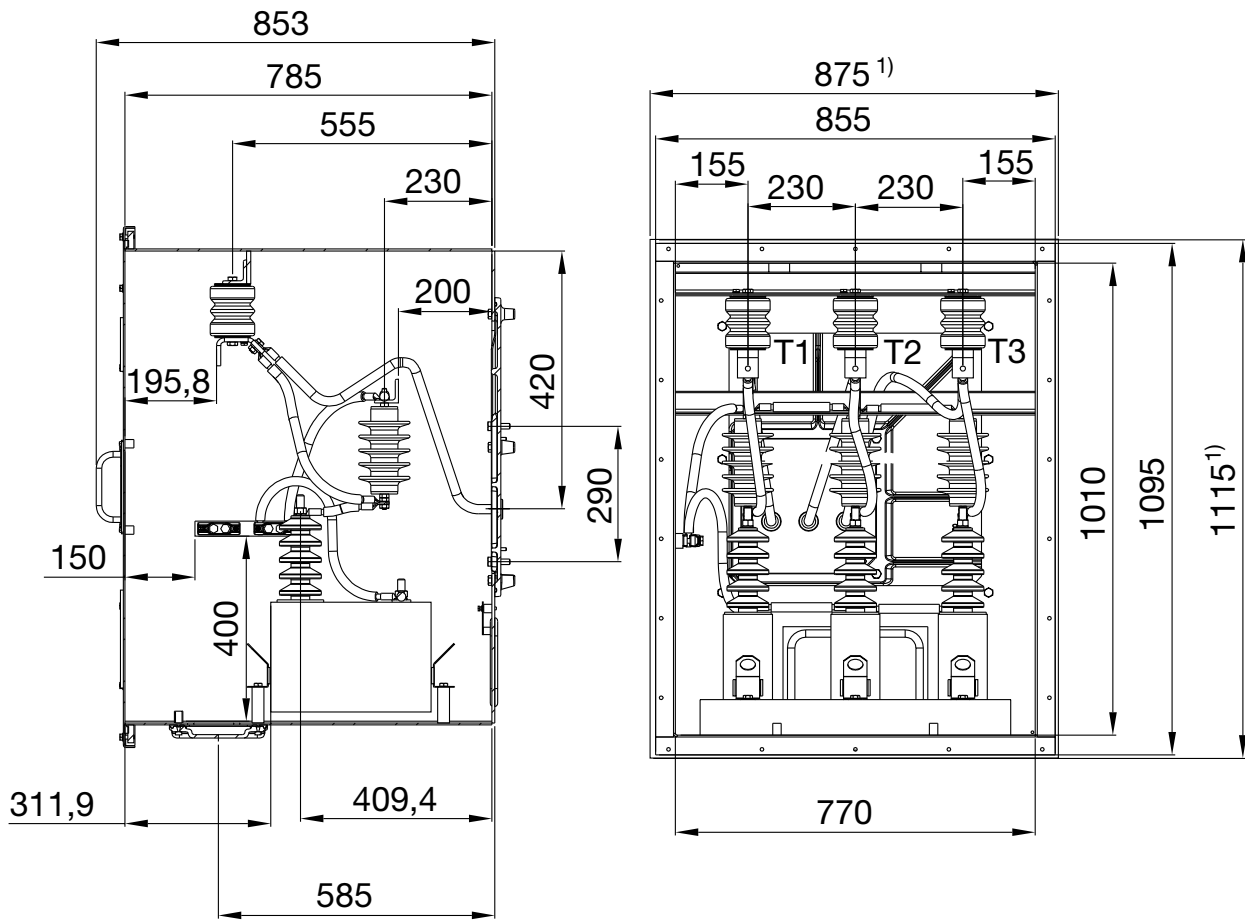

1) Cover dimension.

Technical data	
Maximum quantity of leads	1 per phase
Entry plates for leads designation	Type 01
Internal volume	584 dm ³
Grounding terminal	Internal or external
Approximate weight	285 kg
Degree of protection	IP66
General data	
Minimum terminal box thickness	3,35 mm
Eyebolts	4 eyebolts
Rotate in steps of 90°	
Pressure relief device in the back of the terminal box in case of short circuit	Yes

17.2.6 Steel 09

Dimensions in mm.

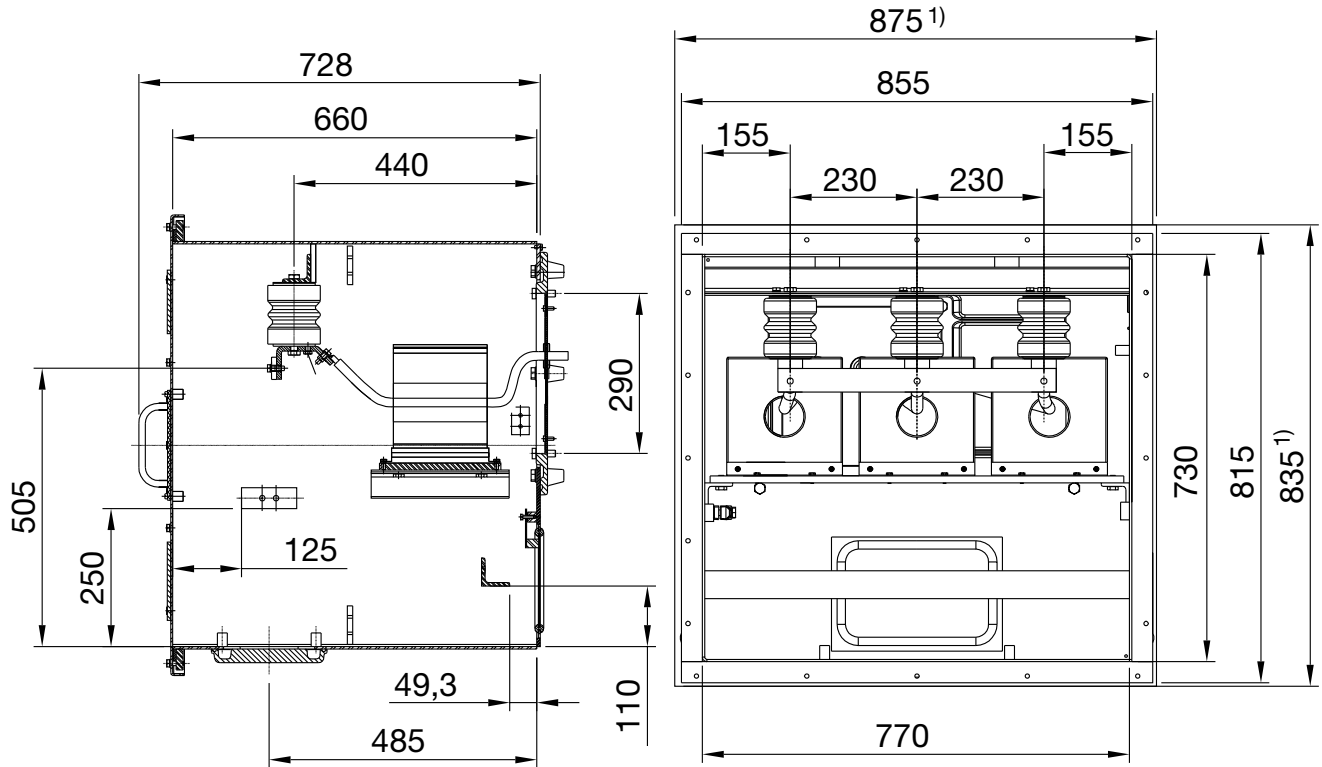

1) Cover dimension.

Technical data	
Maximum quantity of leads	2 per phase
Entry plates for leads designation	Type 01
Internal volume	370,9 dm ³
Grounding terminal	Internal or external
Approximate weight	255 kg
Degree of protection	IP66
General data	
Minimum terminal box thickness	3,35 mm
Eyebolts	4 eyebolts
Rotate in steps of 90°	Yes
Pressure relief device in the back of the terminal box in case of short circuit	

17.2.7 Steel 11

Dimensions in mm.

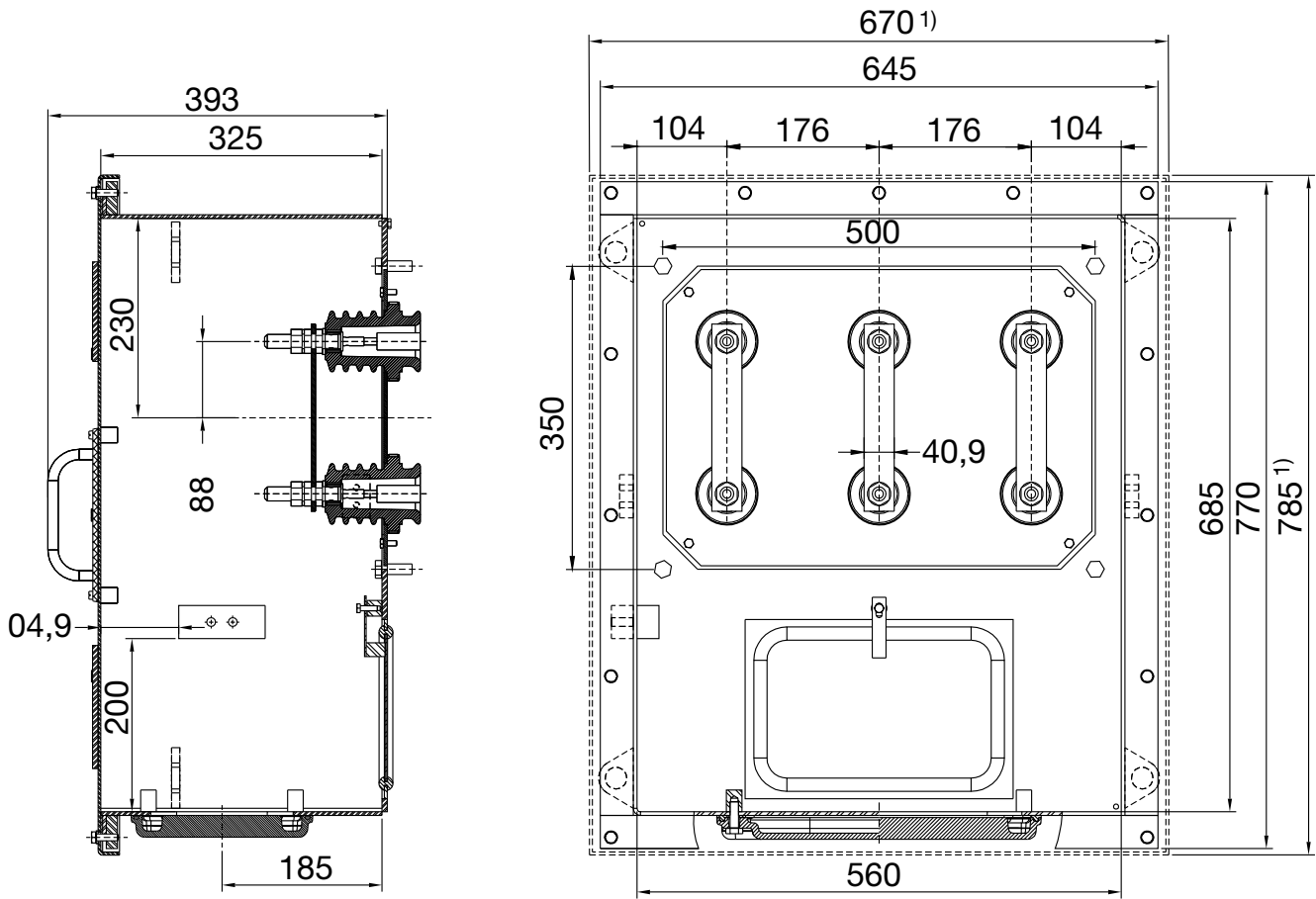

1) Cover dimension.

Technical data	
Maximum quantity of leads	2 per phase
Entry plates for leads designation	Type 01
Internal volume	124,7 dm ³
Grounding terminal	Internal or external
Approximate weight	100 kg
Degree of protection	IP66
General data	
Minimum terminal box thickness	3,35 mm
Eyebolts	4 eyebolts
Rotate in steps of 90°	
Pressure relief device in the back of the terminal box in case of short circuit	Yes

18. Packaging

W51 HD motors in frames 315 to 400 are packaged in wooden pallets (see Figure 63). The dimensions, weights and volumes are listed in the Table 23.

Frame	External height (m)	External width (m)	External length (m)	Weight (kg)	Volume (m ³)
315G/F	0,25	1,60	2,10	124,9	0,840
355H/G		1,40	2,20	115,5	0,770
400H/G		1,80	2,50	201,2	1,26

Table 23 - Wooden pallets dimensions, weights and volumes for motors with side terminal boxes.

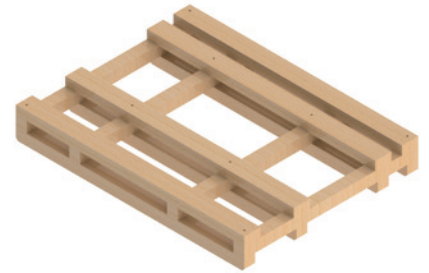

Figure 63 - Wooden pallet.

For frame 450, the motors are packaged in steel pallets (see Figure 64). Dimensions, weights and volumes are in Table 24.

Frame	External height (m)	External width (m)	External length (m)	Weight (kg)	Volume (m ³)
450H/G	0,24	1,70	2,65	132,0	1,081

Table 24 - Steel crates dimensions, weights and volumes for motors with side terminal boxes.

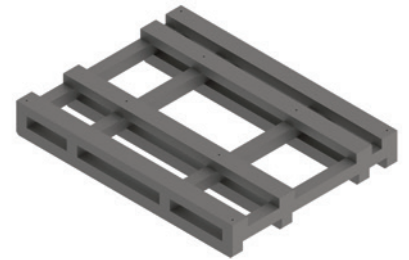
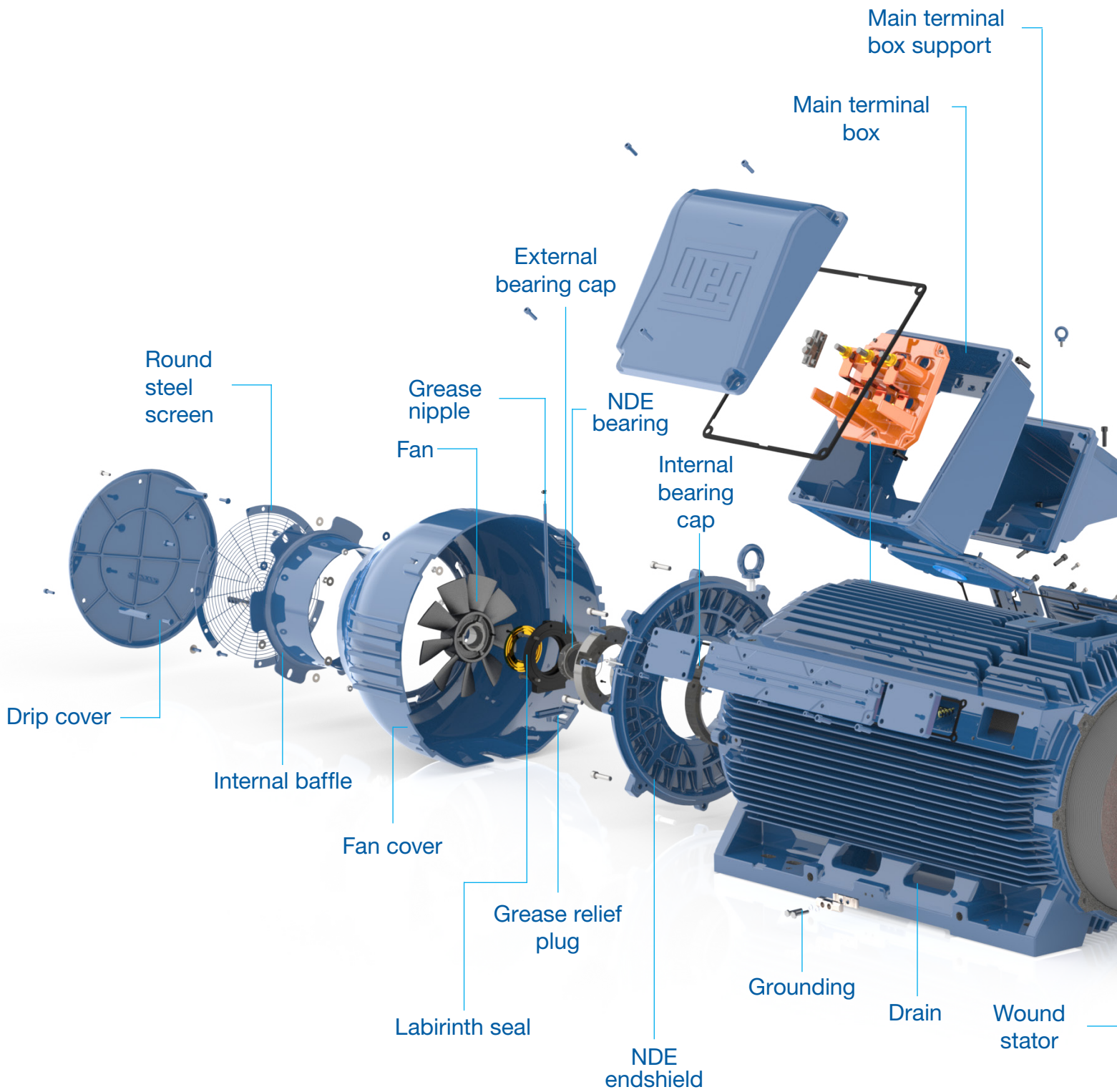
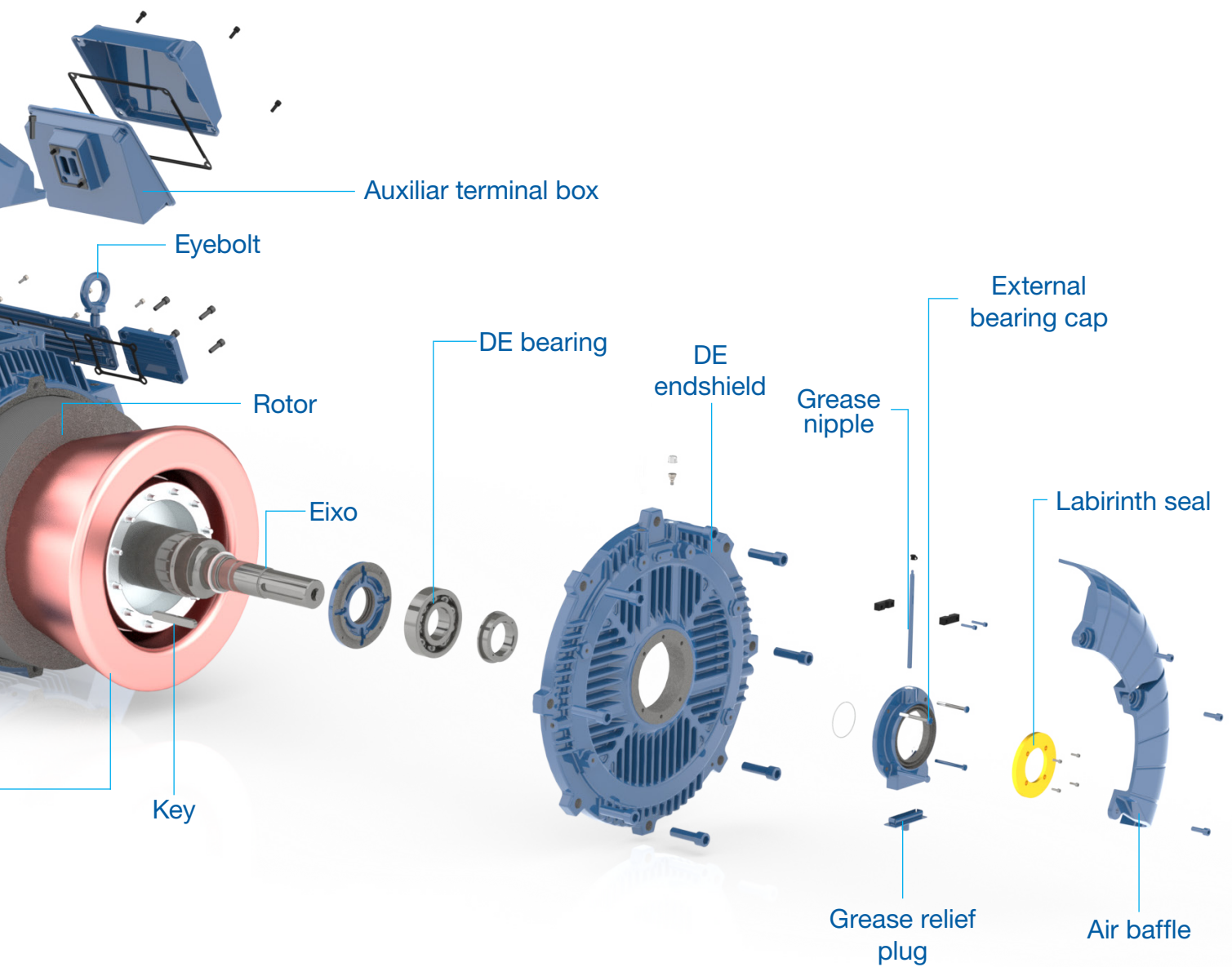

Figure 64 - Steel crates.



19. Spare Parts





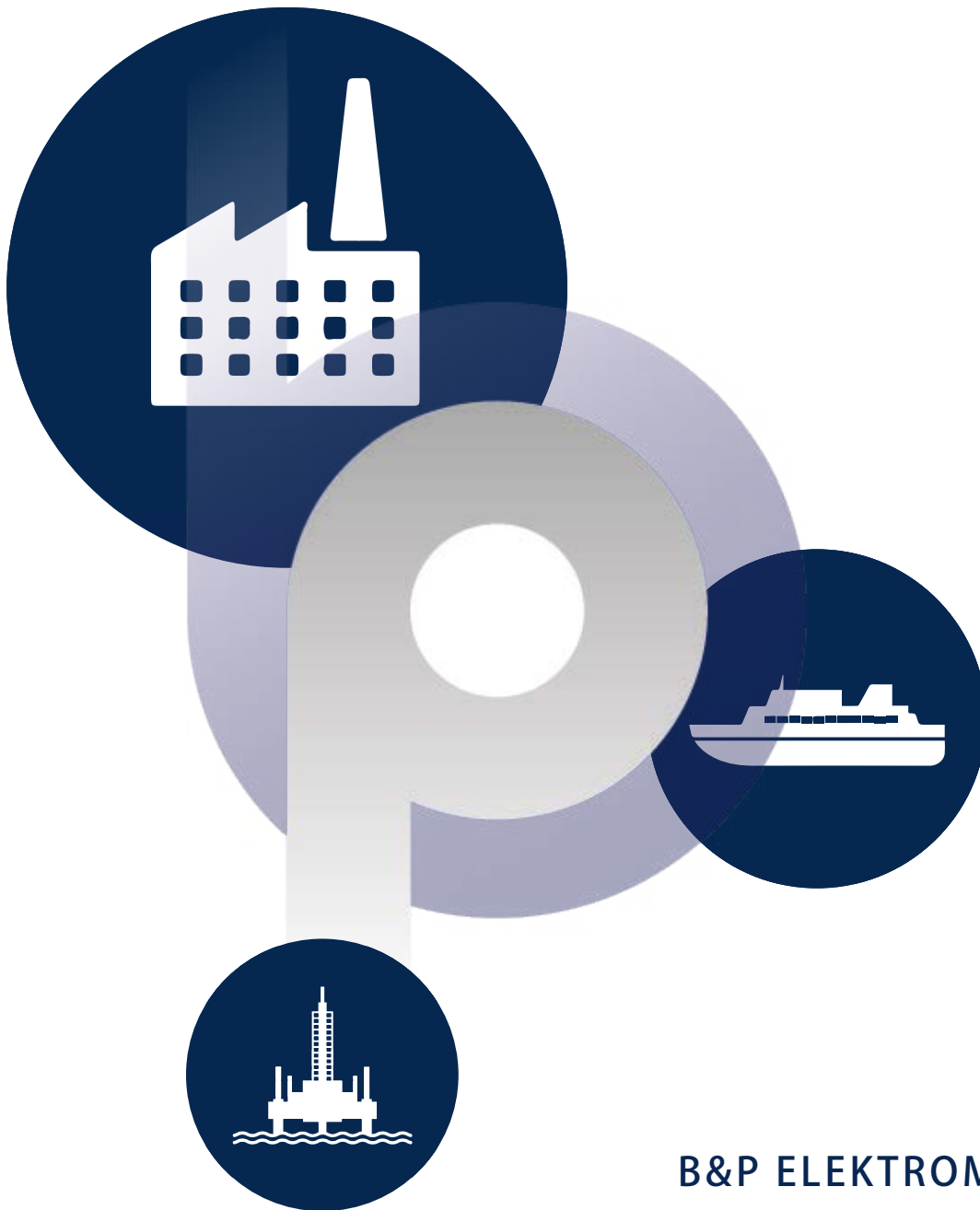

B&P ELEKTROMOTOREN BV

Expeditiweg 21
6657 KM Boven-Leeuwen

info@bnpelektromotoren.nl

+31 (0)344 616 267

BTW nr. NL819113918B01

KvK nr. 30237800

ING Bank NL60 INGB 0675 304 792



www.bnpelektromotoren.nl