

ENGINEERING
TOMORROW

Danfoss

Application Guide

VACON® 100 FLOW



Contents

1	Introduction	11
1.1	Purpose of this Application Guide	11
1.2	Manual and Software Version	11
1.3	Additional Resources	11
1.4	Parameter Table Reading Guide	11
1.5	Functions of the AC Drive	12
1.6	Start-up Quick Guide	13
1.6.1	Start-Up Wizard	13
2	User Interfaces	14
2.1	Description of the Control Panel	14
2.1.1	Control Panel and the Keypad	14
2.1.2	Displays of the Control Panel	14
2.2	Menu Structure	15
2.3	Graphical Display	18
2.3.1	Editing the Text Values	18
2.3.2	Editing the Numerical Values	18
2.3.3	Selecting More than 1 Value	19
2.3.4	Resetting a Fault	19
2.3.5	[FUNCT] Button	19
2.3.5.1	Different Control Places	19
2.3.5.2	Changing the Control Place	20
2.3.5.3	Going into the Control Page	20
2.3.5.4	Changing the Rotation Direction	21
2.3.5.5	Using the Quick Edit Function	22
2.3.6	Copying the Parameters of an AC Drive	22
2.3.7	Comparing the Parameters	23
2.3.8	Reading Help Texts	24
2.3.9	Using the Favourites Menu	24
2.4	Text Display	24
2.4.1	Editing the Text Values	24
2.4.2	Editing the Numerical Values	25
2.4.3	Resetting a Fault	19
2.4.4	[FUNCT] Button	25
2.4.4.1	Different Control Places	19
2.4.4.2	Changing the Control Place	25
2.4.4.3	Going into the Control Page	26

2.4.4.4	Changing the Rotation Direction	27
2.4.4.5	Using the Quick Edit Function	22
2.5	VACON® Live PC Tool	27
3	Applications	29
3.1	Using the Applications	29
3.2	Standard and HVAC Applications	29
3.3	PID Control Application	33
3.4	Multi-pump (Single Drive) Application	37
3.5	Multi-pump (Multidrive) Application	44
4	Wizards	68
4.1	Application Wizards	68
4.1.1	Standard Application Wizard	68
4.1.2	HVAC Application Wizard	68
4.1.3	PID Control Application Wizard	69
4.1.4	Multi-pump (Single Drive) Application Wizard	70
4.1.5	Multi-pump (Multidrive) Application Wizard	72
4.2	Function Wizards	73
4.2.1	Wizards in Menu 1.1	73
4.2.2	Fire Mode Wizard	73
5	Monitor Menu	75
5.1	Uses of the Monitor Menu	75
5.2	Multimonitor Monitoring	75
5.2.1	Changing the Items to Monitor	75
5.3	Trend Curve Monitoring	75
5.3.1	Uses of the Trend Curve	75
5.3.2	Changing the Values in Trend Curve Monitoring	75
5.3.3	Stopping the Progression of the Curve	76
5.3.4	Trend Curve Parameters	77
5.4	Basic Monitoring	77
5.4.1	Uses of the Basic Monitoring	77
5.4.2	Basic Monitoring Parameters	78
5.5	I/O Monitoring	78
5.6	Temperature Inputs	79
5.7	Extras and Advanced	79
5.8	Timer Functions Monitoring	81
5.9	PID Controller Monitoring	81

5.10	External PID Controller Monitoring	82
5.11	Multi-pump Monitoring	82
5.12	Monitoring of Maintenance Counters	83
5.13	Fieldbus Process Data Monitoring	83
5.14	Drive Customizer Monitoring	85
5.15	Condition-based Monitoring	85
6	Parameters Menu	88
6.1	Group 3.1: Motor Settings	88
6.2	Group 3.2: Start/Stop Setup	90
6.3	Group 3.3: References	91
6.4	Group 3.4: Ramps and Brakes Setup	94
6.5	Group 3.5: I/O Configuration	95
6.6	Group 3.6: Fieldbus Data	102
6.7	Group 3.7: Prohibit Frequencies	104
6.8	Group 3.8 Supervisions	104
6.9	Group 3.9: Protections	105
6.10	Group 3.10: Automatic Reset	108
6.11	Group 3.11: Application Settings	109
6.12	Group 3.12: Timer Functions	110
6.13	Group 3.13: PID Controller	112
6.14	Group 3.14: External PID Controller	120
6.15	Group 3.15: Multi-pump	123
6.16	Group 3.16: Maintenance Counters	125
6.17	Group 3.17: Fire Mode	126
6.18	Group 3.18: Motor Preheat Parameters	127
6.19	Group 3.19: Drive Customizer	127
6.20	Group 3.21: Pump Control	127
6.21	Group 3.23: Advanced Harmonic Filter	130
6.22	Group 3.24: Condition-based Monitoring	130
7	Diagnostics Menu	135
7.1	Faults	135
7.1.1	Uses of the Active Faults Submenu	135
7.1.2	Reset Faults	135
7.1.2.1	Resetting Faults with the [BACK/RESET] Button	135
7.1.2.2	Resetting Faults with a Parameter on the Graphical Display	135
7.1.2.3	Resetting Faults with a Parameter on the Text Display	135
7.1.3	Uses of the Fault History	136

7.1.3.1	Examining the Fault History on the Graphical Display	136
7.1.3.2	Examining the Fault History on the Text Display	137
7.2	Counters	137
7.2.1	Using the Counters	137
7.2.2	Total Counters	137
7.2.3	Trip Counters	138
7.3	Software Info	139
7.4	Drive Info	139
7.5	Unit Status	139
8	I/O and Hardware Menu	140
8.1	Basic I/O	140
8.2	Option Board Slots	140
8.3	Real-time Clock	141
8.4	Simple Network Time Protocol (SNTP)	141
8.5	Power Unit Settings	142
8.6	Keypad	142
8.7	Fieldbus	143
8.8	Fieldbus General	145
8.9	STO	146
8.10	Fieldbus Redundancy	146
9	User Settings, Favourites, and User Level Menus	147
9.1	User Settings	147
9.1.1	User Settings Parameters	147
9.1.2	Parameter Back-up Parameters	147
9.1.3	Parameter Compare Parameters	148
9.1.4	License Parameters	148
9.2	Favourites	148
9.2.1	Using the Favourites Menu	148
9.2.2	Adding an Item to the Favourites	148
9.2.3	Removing an Item from the Favourites	148
9.3	User Levels	149
9.3.1	Using the User Levels Menu	149
9.3.2	The User Level Parameters	149
9.3.3	Changing the Access Code of the User Levels	150
10	Monitoring Value Descriptions	151
10.1	Multimonitor	151

10.2	Basic	152
10.3	I/O	153
10.4	Temperature Inputs	154
10.5	Extras and Advanced	155
10.6	Timer Functions	156
10.7	PID Controller	157
10.8	External PID Controller	158
10.9	Multi-pump	158
10.10	Maintenance Counters	159
10.11	Fieldbus Data	159
10.12	Drive Customizer	162
10.13	Condition-based Monitoring	163
10.13.1	Baseline Data	163
10.13.2	Stator Winding Monitor	164
10.13.3	Vibration	164
10.13.4	Load	165
11	Parameter Descriptions	166
11.2	Trend Curve	166
11.3	Motor Settings	167
11.3.1	Motor Nameplate Parameters	167
11.3.2	Motor Control Parameters	167
11.3.3	Motor Limits	171
11.3.4	Open Loop Parameters	171
11.3.5	I/f Start Function	174
11.3.6	Torque Stabilator Function	175
11.4	Start/Stop Setup	176
11.4.1	Start and Stop Commands in Different Control Places	176
11.5	References	184
11.5.1	Frequency Reference	184
11.5.2	Preset Frequencies	185
11.5.3	Motor Potentiometer Parameters	188
11.5.4	Flushing Parameters	189
11.6	Ramps and Brakes Setup	189
11.6.1	Ramp 1	189
11.6.2	Ramp 2	190
11.6.3	Start Magnetizing	192
11.6.4	DC Brake	192

11.6.5 Flux Braking	192
11.7 I/O Configuration	193
11.7.1 Programming of Digital and Analog Inputs	193
11.7.1.1 General Information on the Programming	193
11.7.1.2 Programming of Digital Inputs	194
11.7.1.3 Programming of Digital Inputs in the Graphical Display	196
11.7.1.4 Programming of Digital Inputs in the Text Display	196
11.7.1.5 Programming of Analog Inputs	197
11.7.1.6 Programming of Analog Inputs in the Graphical Display	199
11.7.1.7 Programming of Analog Inputs in the Text Display	199
11.7.2 Descriptions of Signal Sources	199
11.7.3 Default Functions of Programmable Inputs	200
11.7.4 Digital Inputs	200
11.7.5 Analog Inputs	205
11.7.6 Digital Outputs	209
11.7.7 Analog Outputs	212
11.8 Fieldbus Data	215
11.9 Prohibit Frequencies	217
11.10 Supervisions	219
11.11 Protections	219
11.11.1 General	219
11.11.2 Motor Thermal Protections	221
11.11.3 Motor Stall Protection	224
11.11.4 Underload (Dry Pump) Protection	225
11.11.5 Quick Stop	227
11.11.6 AI Low Protection	228
11.12 Automatic Reset	229
11.13 Application Settings	232
11.14 Timer Functions	232
11.14.1 Introduction to Timer Functions	232
11.14.2 Time Channels, Intervals, and Timers	233
11.14.3 Editing an Interval	235
11.15 PID Controller	236
11.15.1 Basic Settings	236
11.15.2 Setpoints	238
11.15.3 Feedback	239
11.15.4 Feedforward	239
11.15.5 Sleep Function	240

11.15.6 Feedback Supervision	243
11.15.7 Pressure Loss Compensation	245
11.15.8 Soft Fill	246
11.15.9 Input Pressure Supervision	247
11.15.10 Sleep Function When No Demand Is Detected	250
11.15.11 Multi-setpoint	251
11.16 External PID Controller	252
11.17 Multi-pump Function	253
11.17.1 The Multi-pump Function	253
11.17.1.1 Commissioning Multi-pump (Multidrive)	253
11.17.2 System Configuration	254
11.17.3 Interlocks	259
11.17.4 Feedback Sensor Connection in a Multi-pump System	259
11.17.5 Overpressure Supervision	266
11.17.6 Pump Run-time Counters	267
11.17.7 Advanced Settings	268
11.18 Maintenance Counters	269
11.18.1 The Maintenance Counters	269
11.19 Fire Mode	270
11.19.1 The Fire Mode Function	270
11.20 Motor Preheat Function	273
11.21 Drive Customizer	274
11.22 Pump Control	274
11.22.1 Auto-Cleaning	274
11.22.2 Jockey Pump	276
11.22.3 Priming Pump	277
11.22.4 Anti-blocking Function	278
11.22.5 Frost Protection	278
11.22.6 Flow Switch	279
11.23 Advanced Harmonic Filter	280
11.24 Condition-based Monitoring	280
11.24.1 Introduction to Condition-based Monitoring	280
11.24.1.1 Stages of Condition-based Monitoring	281
11.24.6 Manual Run	282
11.24.7 Stator Winding Monitoring	283
11.24.8 Threshold Value	283
11.24.9 Warning and Alarm/Fault Stages	284
11.25 Default Values of Parameters in the Different Applications	289

12 Fault Tracing	295
12.1 Fault Types	295
12.2 Alarms and Warnings	295
12.3 Fault Codes	295
12.4 Total and Trip Counters	321
12.4.1 Operating Time Counter	321
12.4.2 Operating Time Trip Counter	321
12.4.3 Run Time Counter	322
12.4.4 Power on Time Counter	322
12.4.5 Energy Counter	323
12.4.6 Energy Trip Counter	324

1 Introduction

1.1 Purpose of this Application Guide

This Application Guide provides information for configuring the system, controlling the AC drive, accessing parameters, programming, and troubleshooting of the AC drive. It is intended for use by qualified personnel. Read and follow the instructions to use the drive safely and professionally. Pay particular attention to the safety instructions and general warnings that are provided in this manual and other documentation delivered with the drive.

1.2 Manual and Software Version

This manual is regularly reviewed and updated. All suggestions for improvement are welcome. The original language of this manual is English.

Table 1: Manual and Software Version

Edition	Software version
DPD01083I	FW0159V028

1.3 Additional Resources

Other resources are available to understand advanced AC drive functions and operation.

- VACON® 100 Wall-mounted Drives Operating Guide
- VACON® 100 Enclosed Drives Installation Manual
- VACON® 100 IP00 Drive Modules Installation Manual
- VACON® 100 X Installation Manual
- Instructions for operation with option boards and other optional equipment.

Supplementary publications and manuals are available from Danfoss.

For US and Canadian markets:

NOTE! Download the English and French product guides with applicable safety, warning and caution information from <https://www.danfoss.com/en/service-and-support/>.

REMARQUE Vous pouvez télécharger les versions anglaise et française des guides produit contenant l'ensemble des informations de sécurité, avertissements et mises en garde applicables sur le site <https://www.danfoss.com/en/service-and-support/>.

1.4 Parameter Table Reading Guide

This manual includes a large quantity of parameter tables. These instructions tell you how to read the tables.

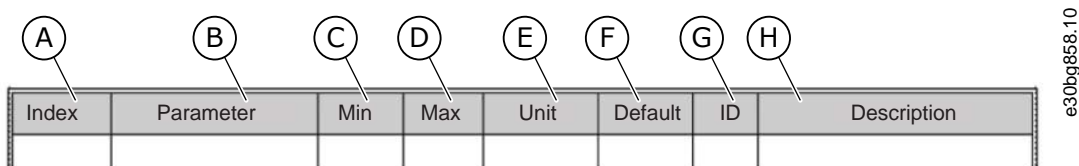

Illustration 1: Parameter Table Reading Guide

<p>A The location of the parameter in the menu, that is, the parameter number.</p> <p>B The name of the parameter.</p> <p>C The minimum value of the parameter.</p> <p>D The maximum value of the parameter.</p>	<p>E The unit of the value of the parameter. The unit shows if it is available.</p> <p>F The value that was set in the factory.</p> <p>G The ID number of the parameter.</p> <p>H A short description of the values of the parameter and/or its function.</p>
--	---

1.5 Functions of the AC Drive

- Easy setup functions
 - Applications with preset parameters and I/O configuration for your process: Standard, HVAC, PID control, Multi-pump
 - Start-up wizards for fast and easy parameterization
- Navigation functions
 - The [FUNCT] button for an easy change between the local and the remote control place (I/O or fieldbus)
 - A control page to operate and monitor of the most important values quickly
- Advanced monitoring functions
 - Multimonitor
 - Trend curve
- Fieldbus and I/O control
- Motor control
 - Open loop control with frequency reference
 - Support for induction, permanent magnet, and synchronous reluctance motors
 - Identification run for setup of motor parameters
 - Flux and DC brake
- Start and stop logic configuration
- Reference selection and handling
 - 8 preset frequencies
 - Motor potentiometer functions
 - A flush function
 - 2 programmable ramp times
 - 2 supervisions
 - 3 ranges of prohibited frequencies
 - A forced stop
- PID control
 - An external PID controller is available. Use it, for example, to control a valve with the I/O of the AC drive.
 - A sleep mode function that automatically enables and disables the operation of the drive to save energy
 - A 2-zone PID controller with 2 different feedback signals: minimum and maximum control
 - 2 setpoint sources for the PID control. Selection to be made with a digital input.
 - A function for PID setpoint boost
 - A feedforward function to make the response to the process changes better
- Pump control
 - A multi-pump control for the single drive and multidrive systems
 - The multimaster and multifollower modes in the multidrive system
 - A multi-pump system that uses a real time clock to autochange the pumps
 - Priming pump control, jockey pump control, pump impeller auto-cleaning, pump input pressure supervision, and frost protection function
- Mechanical brake control
- Timer functions and a real-time clock and (an optional battery is necessary)
- Fire mode
- Diagnostic and maintenance functions
 - Variety of configurable protection functions including user-defined faults
 - Supervision functions for frequency and motor variables and analog inputs
 - Motor overload protections

- An automatic reset
- Different preheat modes to prevent condensation problems
- Maintenance counters
- Drive Customizer for custom logic programming
- Control, parametrization, and diagnostics via PC-tools

1.6 Start-up Quick Guide

There are 5 applications available for the product. When an application is selected, a group of parameters get their preset values. The selection of the application makes the commissioning of the drive easy and reduces the manual work with the parameters. It is also possible to edit these parameters later.

⚠ W A R N I N G ⚠

ACCIDENTAL START BECAUSE OF CHANGE OF SETTINGS

Running the Startup wizard, changing the application or the software can cause the I/O functions to change.

- Disconnect the motor from the drive if an accidental start can be dangerous.

The available applications:

- Standard application ([3.2 Standard and HVAC Applications](#))
- HVAC application ([3.2 Standard and HVAC Applications](#))
- PID control application ([3.3 PID Control Application](#))
- Multi-pump (single drive) application ([3.4 Multi-pump \(Single Drive\) Application](#))
- Multi-pump (double drive) application ([3.5 Multi-pump \(Multidrive\) Application](#))

Wizards make it more convenient to use the AC drive. There is a start-up wizard (see [1.6.1 Start-Up Wizard](#)), 5 applications wizards (see [4.1 Application Wizards](#)), and 1 function wizard (see [4.2.2 Fire Mode Wizard](#)).

1.6.1 Start-Up Wizard

The Start-up wizard asks for necessary data for the drive to control the procedure.

Procedure

1. Select language (P6.1).

If a battery is installed, the steps 2–5 are shown.

2. Set daylight saving time (P5.5.5). (Russia, US, EU, or OFF)
3. Set time (P5.5.2).
4. Set year (P5.5.4).
5. Set date (P5.5.3).
6. Run Startup wizard?

If the selection is No, the Start-up wizard ends.

7. Select an application (P1.2 Application, ID 212).
8. Run the Application wizard?
 - a. To continue to the application wizard, set the selection to Yes and push the [OK] button. See the description of the different application wizards in chapter [4.1 Application Wizards](#).

➡ After these selections, the Start-up wizard is completed. To start the Start-up wizard again, there are 2 alternatives. Go to the parameter P6.5.1 Restore Factory Defaults or to the parameter B1.1.1 Start-up Wizard. Then set the value to Activate.

2 User Interfaces

2.1 Description of the Control Panel

2.1.1 Control Panel and the Keypad

The control panel is the interface between the AC drive and the user. With the control panel, it is possible to control the speed of a motor and monitor the status of the AC drive. It is also possible to set the parameters of the AC drive.

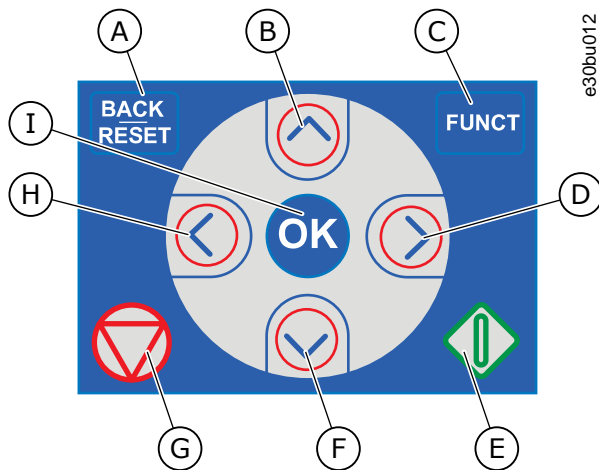

Illustration 2: Buttons of the VACON® 100 Keypad

A	The [BACK/RESET] button. Use it to move back in the menu, exit the Edit mode, reset a fault.	F	The arrow button DOWN. Use it to scroll the menu down and to decrease a value.
B	The arrow button UP. Use it to scroll up the menu and to increase a value.	G	The STOP button.
C	The [FUNCT] button. Use it to change the rotation direction of the motor, access the control page, and change the control place.	H	The arrow button LEFT. Use it to move the cursor left.
D	The arrow button RIGHT.	I	The [OK] button. Use it to go into an active level or item, or to accept a selection.
E	The START button.		

2.1.2 Displays of the Control Panel

There are 2 display types: the graphical display and the text display. The control panel always has the same keypad and buttons. The display shows this data.

- The status of the motor and the drive.
- Faults in the motor and in the drive.
- Your location in the menu structure.

If the text in the text display is too long for the display, the text scrolls to show the full text string. Some functions are only available in the graphical display.

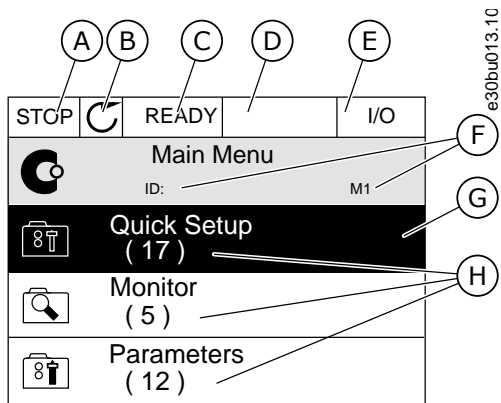

Illustration 3: Graphical Display of the Control Panel

A	The first status field: <i>STOP/RUN</i>	E	The control place field: <i>PC//O/KEYPAD/ FIELDBUS</i>
B	The rotation direction of the motor	F	The location field: the ID number of the parameter and the current location in the menu
C	The second status field: <i>READY/NOT READY/FAULT</i>	G	An activated group or item
D	The alarm field: <i>ALARM/-</i>	H	The number of items in the group in question

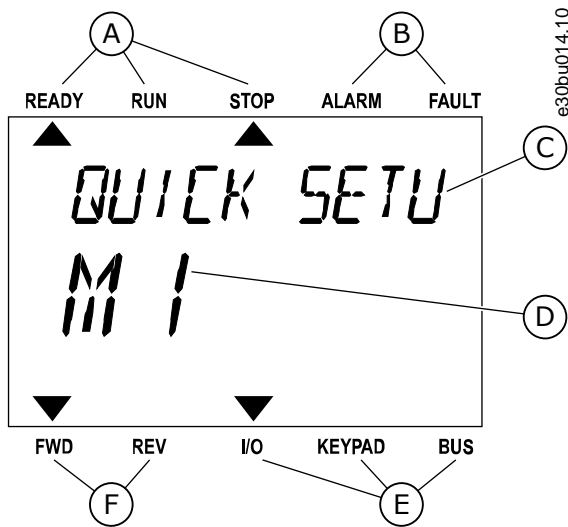

Illustration 4: Text Display of the Control Panel

A	The indicators of status	D	The current location in the menu
B	The indicators of alarm and fault	E	The indicators of the control place
C	The name of the group or item of the current location	F	The indicators of the rotation direction

2.2 Menu Structure

The data of the AC drive is in menus and submenus. To move between the menus, use the arrow buttons Up and Down in the keypad. To go into a group or an item, push the [OK] button. To go back to the previous level, push the [BACK/RESET] button.

On the display, current location in the menu shows, for example M3.2.1. The display also shows the name of the group or item in the current location.

Table 2: Menu Structure

Menu	Function
M1 Quick setup	Wizards (Content depends on P1.2 Application.)
M2 Monitor	Multimonitor
	Trend curve
	Basic
	I/O
	Temperature inputs
	Extras/Advanced
	Timer functions
	PID controller
	External PID controller
	Multi-pump
	Maintenance counters
	Fieldbus data
	Drive customizer
	Condition-based monitoring
M3 Parameters	Motor settings
	Start/Stop setup
	References
	Ramps and brakes
	I/O Configuration
	Fieldbus data
	Prohibit frequencies
	Supervisions
	Protections
	Automatic reset
	Application settings
	Timer functions
	PID controller
	External PID controller
	Multi-Pump
	Maintenance counters
	Fire mode

Menu	Function
	Motor preheat
	Drive customizer
	Pump control
	Advanced harmonic filter
	Condition-based monitoring
M4 Diagnostics	Active faults
	Reset faults
	Fault history
	Total counters
	Trip counters
	Software info
	Drive info
	Unit status
M5 I/O and Hardware	Basic I/O
	Slot C
	Slot D
	Slot E
	Real-time clock
	Power unit settings
	Keypad
	RS485
	Ethernet
	Fieldbus general
M6 User settings	Language selections
	Parameter back-up
	Drive name
	Parameter compare
	Licenses
M7 Favourites	See 9.2.1 Using the Favourites Menu .
M8 User levels	See 9.3.1 Using the User Levels Menu .

2.3 Graphical Display

2.3.1 Editing the Text Values

This topic gives instructions on how to edit the text values on the graphical display.

Procedure

1. Find the parameter with the arrow buttons.
2. To go to the *Edit* mode, push the [OK] button 2 times or push the arrow button Right.

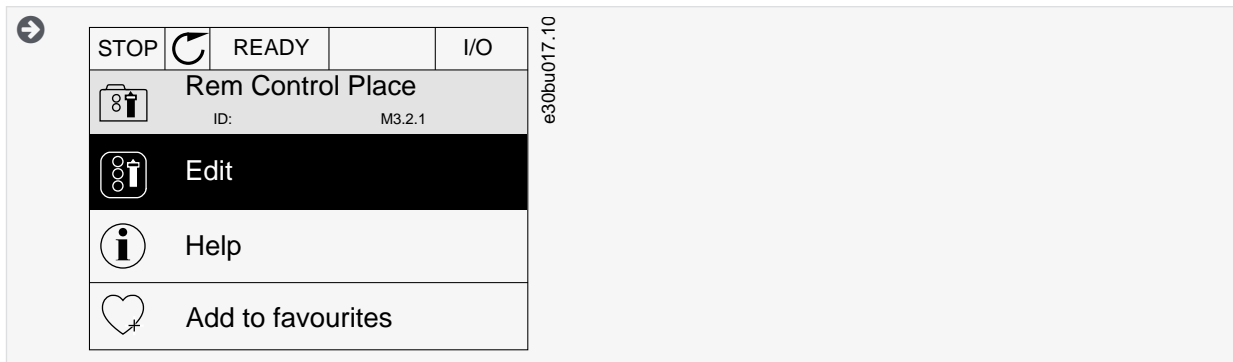

3. To set a new value, push the arrow buttons Up and Down.

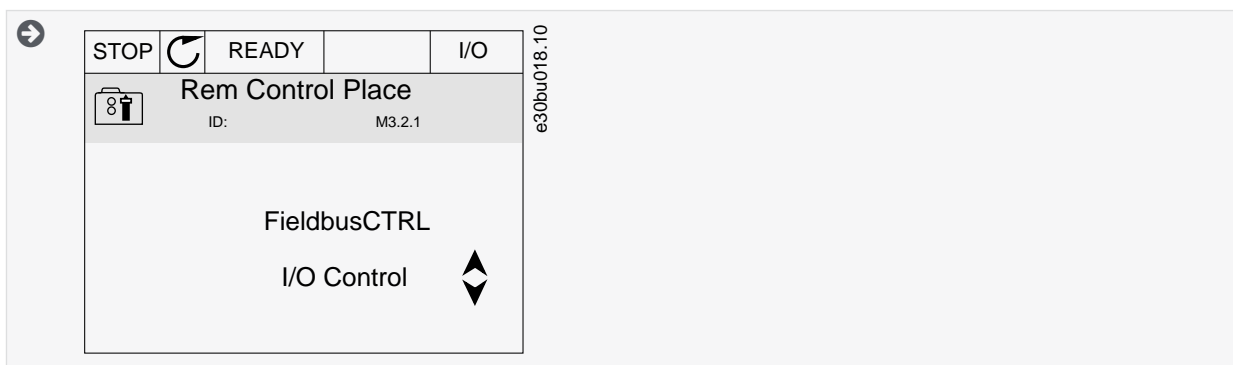

4. To accept the change, push the [OK] button. To ignore the change, use the [BACK/RESET] button.

2.3.2 Editing the Numerical Values

This topic gives instructions on how to edit the numerical values on the graphical display.

Procedure

1. Find the parameter with the arrow buttons.
2. To go to the *Edit* mode, push the [OK] button 2 times or push the arrow button Right.
3. Move from digit to digit with the arrow buttons Left and Right. Change the digits with the arrow buttons Up and Down.

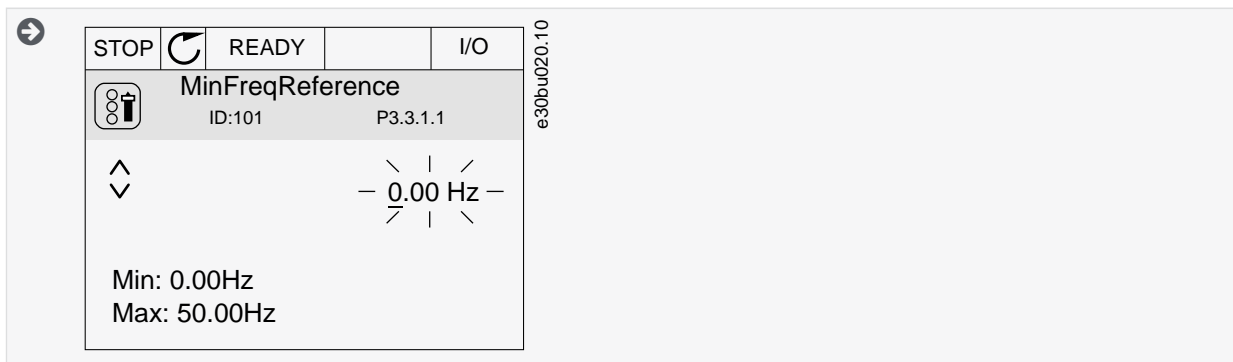

4. To accept the change, push the [OK] button. To ignore the change, use the [BACK/RESET] button.

2.3.3 Selecting More than 1 Value

With some parameters, more than 1 value can be selected. Select a checkbox at each necessary value.

Procedure

1. Find the parameter. There is a symbol on the display when a checkbox selection is possible.

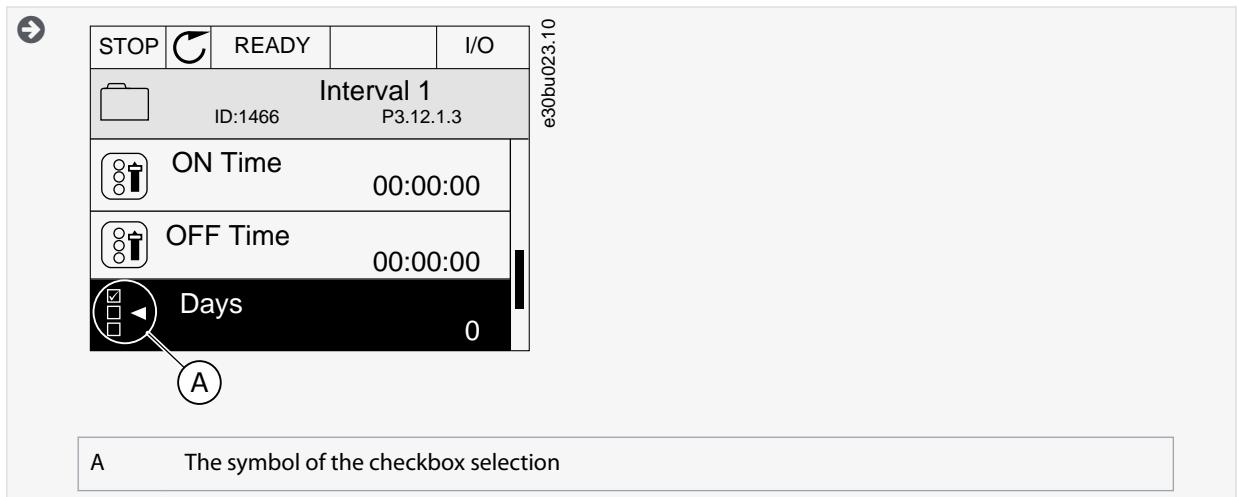

2. To move in the list of values, use the arrow buttons Up and Down.
3. To add a value into your selection, select the box that is next to it with the arrow button Right.

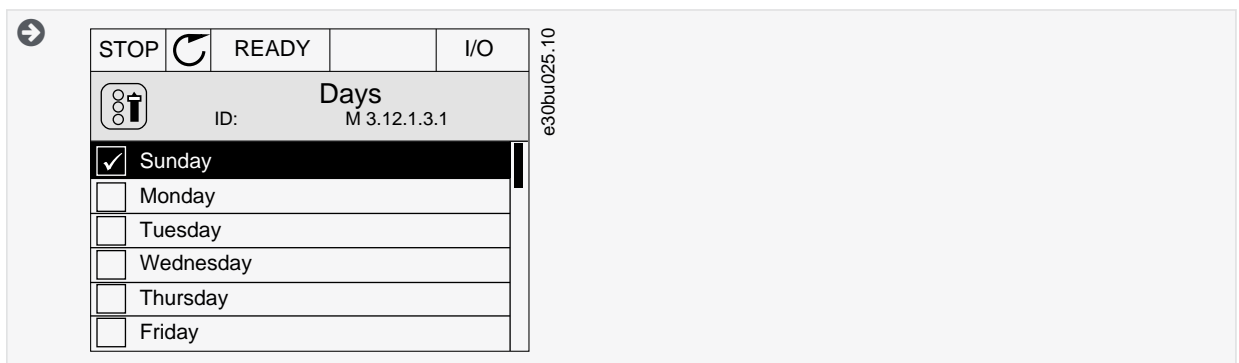

2.3.4 Resetting a Fault

To reset a fault, use the [BACK/RESET] button or the parameter Reset Faults. See [7.1.2 Reset Faults](#).

2.3.5 [FUNCT] Button

The [FUNCT] button can be used for 4 functions.

- To have access to the Control page.
- To change easily between the Local and Remote control places.
- To change the rotation direction.
- To edit quickly a parameter value.

2.3.5.1 Different Control Places

The selection of the control place determines from where the AC drive takes the start and stop commands. All the control places have a parameter for the selection of the frequency reference source. The Local control place is always *Keypad*. The Remote control place is *I/O* or *Fieldbus*. The status bar of the display shows the current control place.

It is possible to use *I/O A*, *I/O B*, and *Fieldbus* as Remote control places. *I/O A* and *Fieldbus* have the lowest priority. Select them with P3.2.1 (Remote Control Place). *I/O B* can bypass the Remote control places *I/O A* and *Fieldbus* with a digital input. Select the digital input with parameter P3.5.1.7 (I/O B Control Force).

Keypad is always used as a control place when the control place is Local. Local control has higher priority than Remote control. For example, if parameter P3.5.1.7 bypasses the control place with a digital input, and Local is selected in Remote control, *Keypad* becomes the control place. Use the [FUNCT] button or P3.2.2 Local/Remote to change between the Local and Remote control.

2.3.5.2 Changing the Control Place

This topic gives instructions on how to change the control place on the control panel.

Procedure

1. Anywhere in the menu structure, push the [FUNCT] button.
2. To select Local/Remote, use the arrow buttons Up and Down. Push the [OK] button.

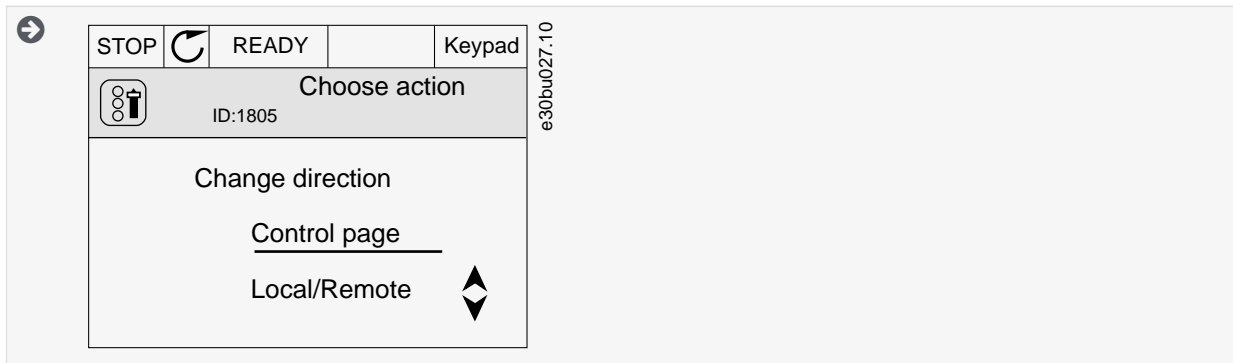

3. To select Local or Remote, use the arrow buttons Up and Down again. To accept the selection, push the [OK] button.

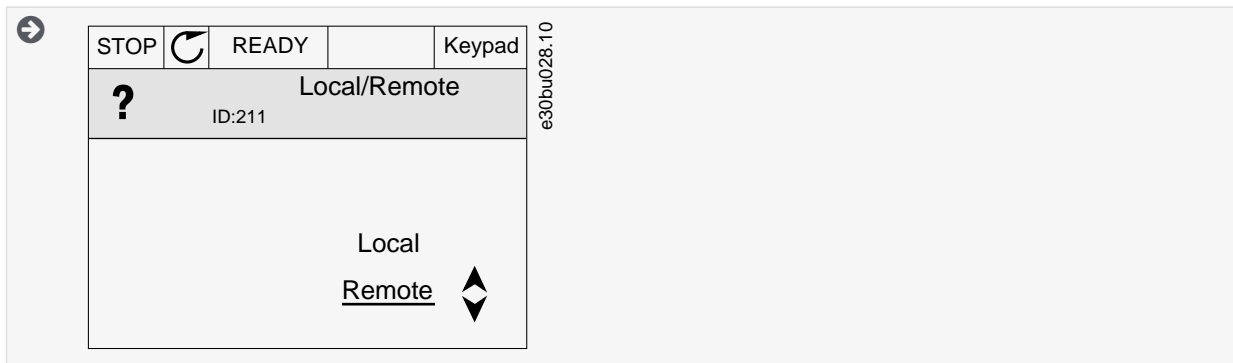

4. If Remote control place is changed to Local, that is, *Keypad*, give a keypad reference.

➡ After the selection, the display goes back into the same location where it was when the [FUNCT] button was pushed.

2.3.5.3 Going into the Control Page

It is easy to monitor the most important values in the *Control page*.

See more information about Keypad Reference in [6.3 Group 3.3: References](#). If other control places or reference values are used, the display shows the frequency reference, which cannot be edited. The other values on the page are *Multimonitor* values. These values can be selected (see [5.2.1 Changing the Items to Monitor](#)).

Procedure

1. Anywhere in the menu structure, push the [FUNCT] button.
2. To select the *Control page*, push the arrow buttons Up and Down. Go in with the [OK] button.

➡ The *Control page* opens.

3. With the Local control place and the keypad reference selected, P3.3.1.8 Keypad Reference can be set with the [OK] button.

- To change the digits in the value, push the arrow buttons Up and Down. Accept the change with the [OK] button.

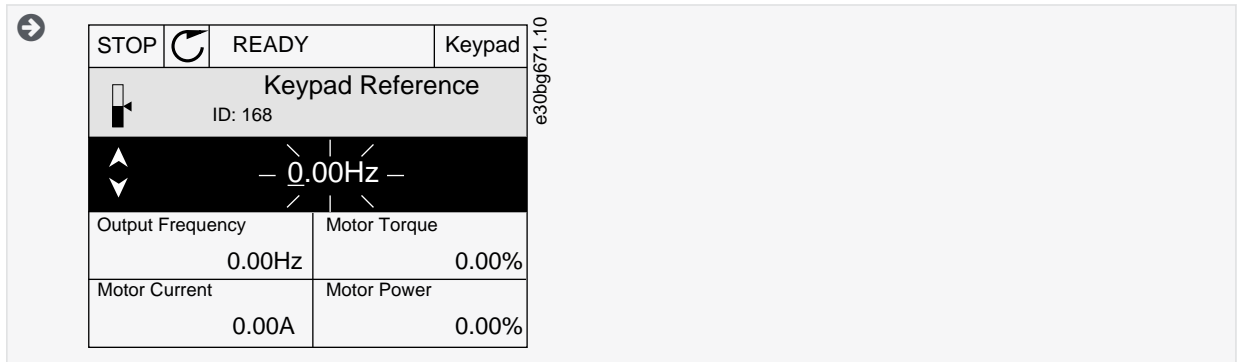

2.3.5.4 Changing the Rotation Direction

The rotation direction of the motor can be changed quickly with the [FUNCT] button.

NOTICE

The command *Change direction* is available in the menu only if the current control place is Local.

Procedure

- Anywhere in the menu structure, push the [FUNCT] button.
- To select *Change direction*, push the arrow buttons Up and Down. Push the [OK] button.
- Select a new rotation direction.

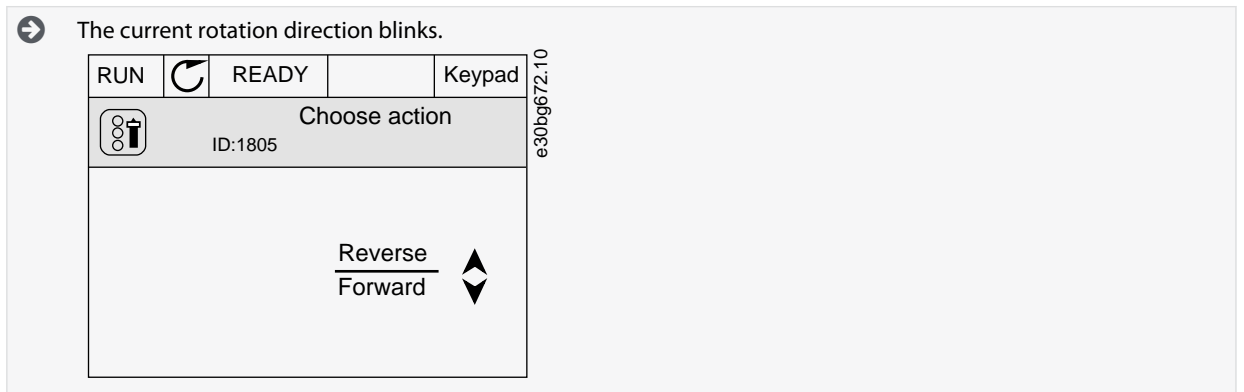

- Push the [OK] button.

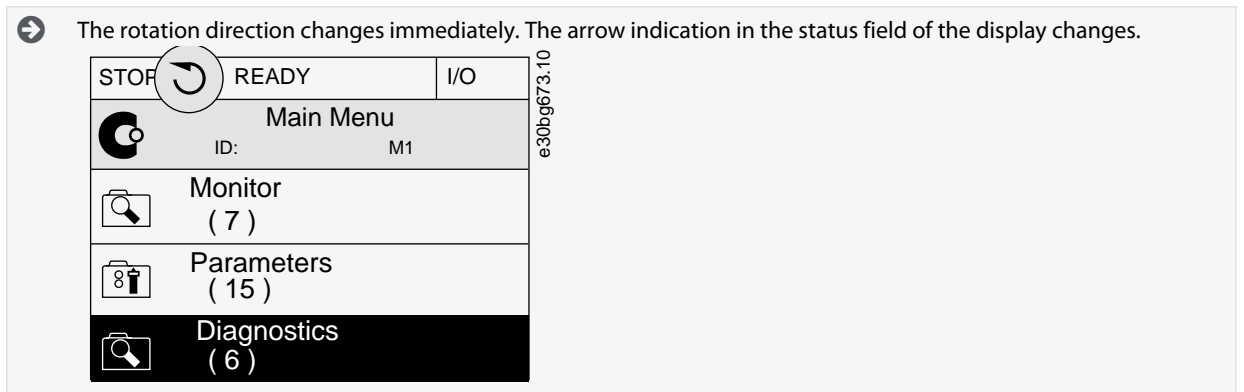

2.3.5.5 Using the Quick Edit Function

With the *Quick Edit* function, a parameter can be accessed quickly by typing the ID number of the parameter.

Procedure

1. Anywhere in the menu structure, push the [FUNCT] button.
2. Push the arrow buttons Up and Down to select *Quick Edit* and accept with the [OK] button.
3. Write the ID number of a parameter or monitoring value. Push [OK].

➡ The display shows the parameter value in the edit mode and the monitoring value in the monitoring mode.

2.3.6 Copying the Parameters of an AC Drive

Use this function to copy parameters from a drive to another. Before downloading parameters from the control panel to the drive, stop the drive.

N O T I C E

This function is available only in the graphical display.

Procedure

1. Save the parameters to the control panel.
 - a. Go into the *User settings* menu.
 - b. Go into the *Parameter backup* submenu.

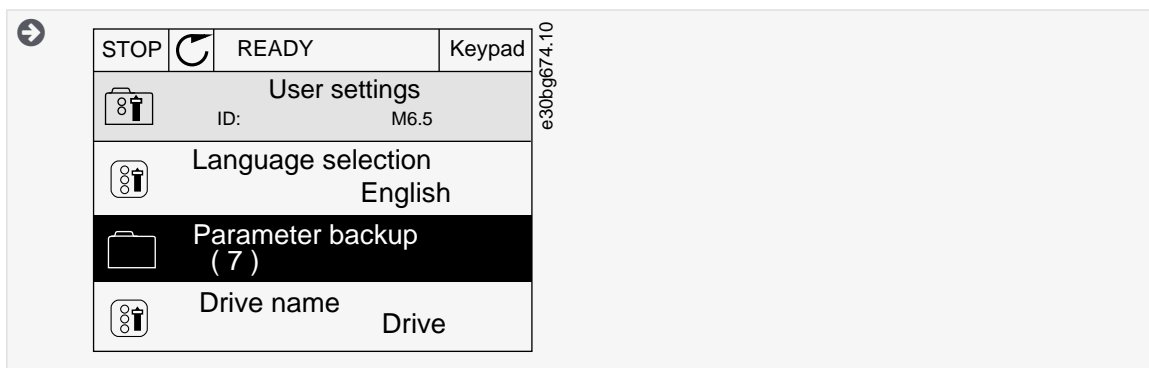

- c. Use the arrow buttons Up and Down to select a function. Accept the selection with the [OK] button.

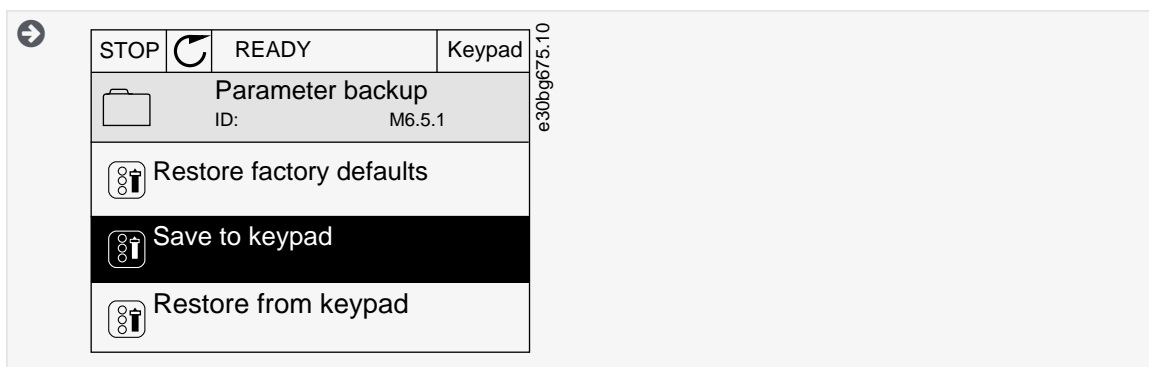

The command *Restore factory defaults* brings back the parameter settings that were made at the factory. Use the command *Save to keypad* to copy all the parameters to the control panel. The command *Restore from keypad* copies all the parameters from the control panel to the drive.

2. Detach the control panel and connect it to another drive.
3. Download the parameters to the new drive with the command *Restore from keypad*.

2.3.7 Comparing the Parameters

Use this function to compare the current parameter set with one of these 4 sets. See more about these parameters in [9.1.2 Parameter Back-up Parameters](#).

- Set 1 (P6.5.4 Save to Set 1)
- Set 2 (P6.5.6 Save to Set 2)
- Defaults (P6.5.1 Restore Factory Defaults)
- Keypad set (P6.5.2 Save to Keypad)

NOTICE

If the parameter set with which the current set is compared was not saved, the display shows the text *Comparing failed*.

Procedure

1. Go into the *User settings* menu.
2. Go into the *Parameter Compare* function.

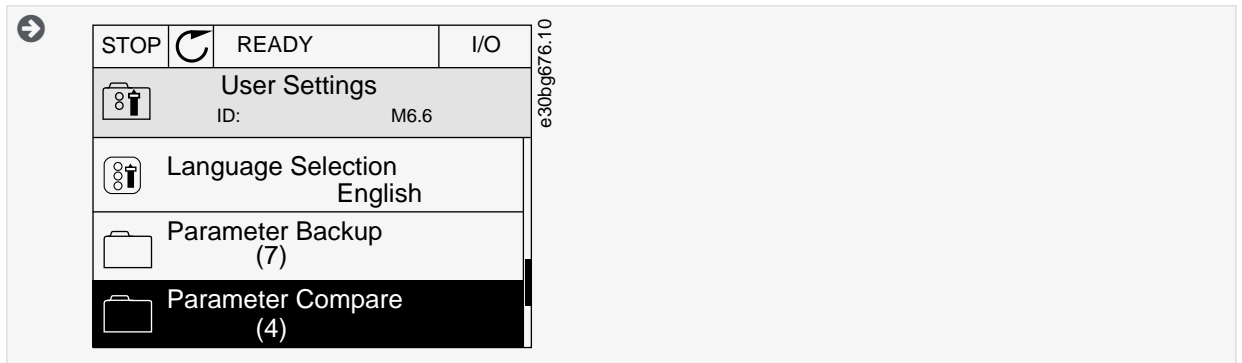

3. Select the pair of sets. Push [OK] to accept the selection.

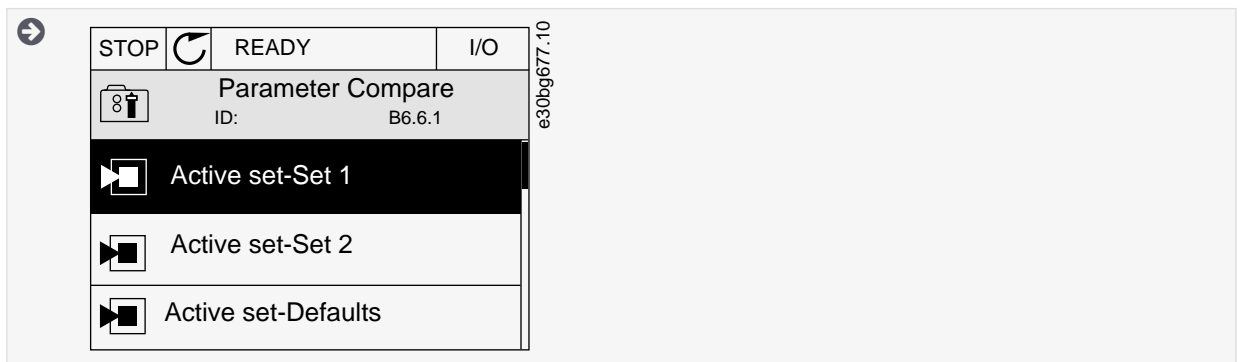

4. Select *Active* and push [OK].
5. Examine the comparing between the current values and the values of the other set.

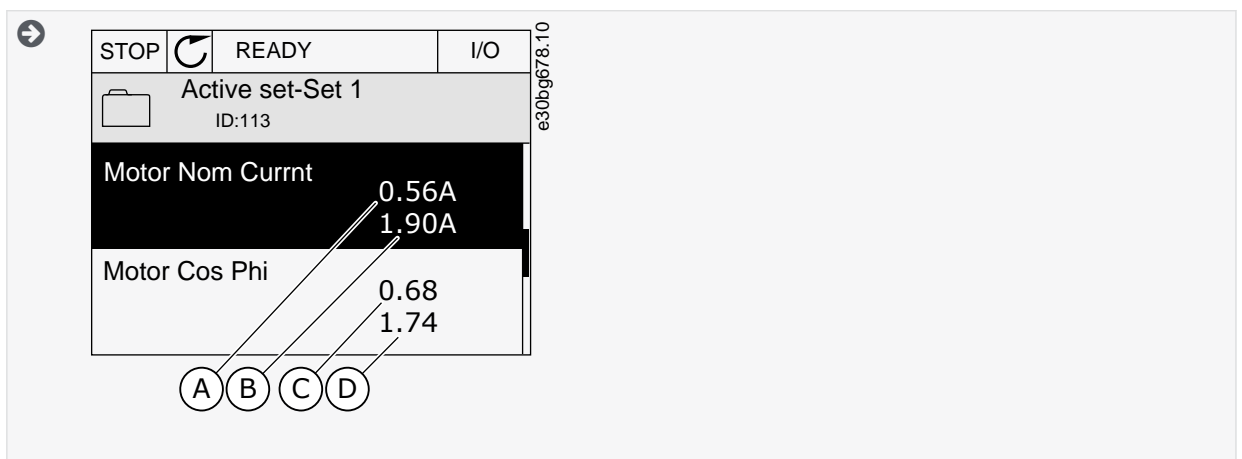

A	The current value	C	The current value
B	The value of the other set	D	The value of the other set

2.3.8 Reading Help Texts

The graphical display can show help texts on many topics. All the parameters have a help text. The help texts are also available for the faults, alarms, and the start-up wizard.

N O T I C E

The help texts are always in English.

Procedure

1. Find the item to read.
2. Use the arrow buttons Up and Down to select *Help*.

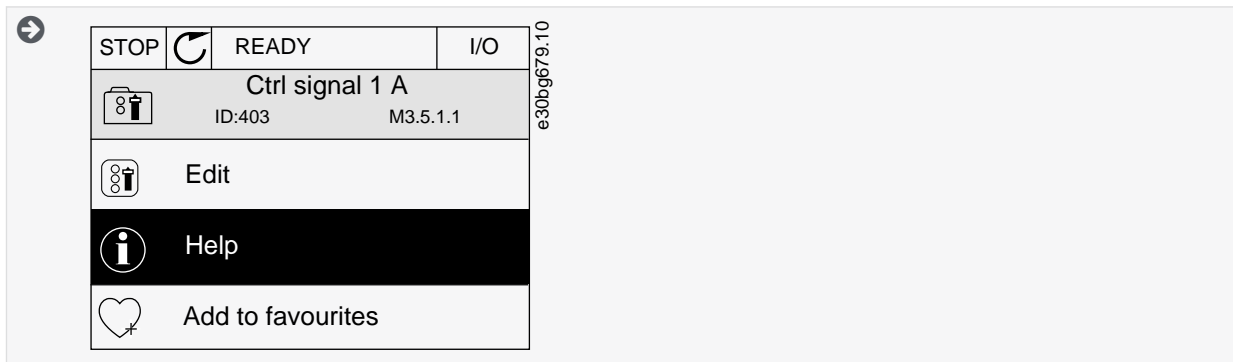

3. To open the help text, push the [OK] button.

2.3.9 Using the Favourites Menu

If the same items are used frequently, add them into *Favourites*. Collect a set of parameters or monitoring signals from all the control panel menus. See [9.2.2 Adding an Item to the Favourites](#).

2.4 Text Display

2.4.1 Editing the Text Values

This topic gives instructions on how to edit text values on the text display.

Procedure

1. Find the parameter with the arrow buttons.
2. To go to the Edit mode, push the [OK] button.
3. To set a new value, push the arrow buttons Up and Down.

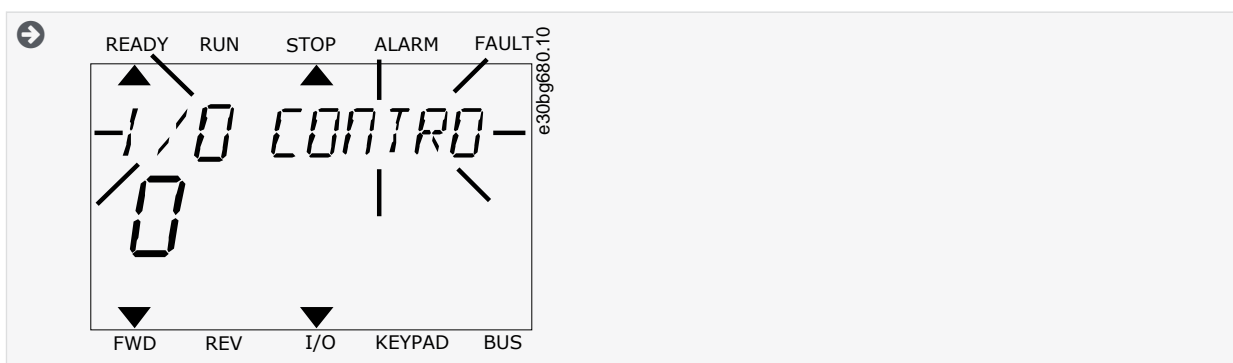

4. Accept the change with the [OK] button. To ignore the change, use the [BACK/RESET] button.

2.4.2 Editing the Numerical Values

This topic gives instructions on how to edit the numerical values on the text display.

Procedure

1. Find the parameter with the arrow buttons.
2. Go to the Edit mode.
3. Move from digit to digit with the arrow buttons Left and Right. Change the digits with the arrow buttons Up and Down.
4. Accept the change with the [OK] button. To ignore the change, use the [BACK/RESET] button.

2.4.3 Resetting a Fault

To reset a fault, use the [BACK/RESET] button or the parameter Reset Faults. See [7.1.2 Reset Faults](#).

2.4.4 [FUNCT] Button

The [FUNCT] button can be used for 4 functions.

- To have access to the *Control page*.
- To change easily between the Local and Remote control places.
- To change the rotation direction.
- To edit quickly a parameter value.

2.4.4.1 Different Control Places

The selection of the control place determines from where the AC drive takes the start and stop commands. All the control places have a parameter for the selection of the frequency reference source. The Local control place is always *Keypad*. The Remote control place is *I/O* or *Fieldbus*. The status bar of the display shows the current control place.

It is possible to use *I/O A*, *I/O B*, and *Fieldbus* as Remote control places. *I/O A* and *Fieldbus* have the lowest priority. Select them with P3.2.1 (Remote Control Place). *I/O B* can bypass the Remote control places *I/O A* and *Fieldbus* with a digital input. Select the digital input with parameter P3.5.1.7 (*I/O B Control Force*).

Keypad is always used as a control place when the control place is Local. Local control has higher priority than Remote control. For example, if parameter P3.5.1.7 bypasses the control place with a digital input, and Local is selected in Remote control, *Keypad* becomes the control place. Use the [FUNCT] button or P3.2.2 Local/Remote to change between the Local and Remote control.

2.4.4.2 Changing the Control Place

This topic gives instructions on how to change the control place on the control panel.

Procedure

1. Anywhere in the menu structure, push the [FUNCT] button.
2. To select *Local/Remote*, use the arrow buttons Up and Down. Push the [OK] button.

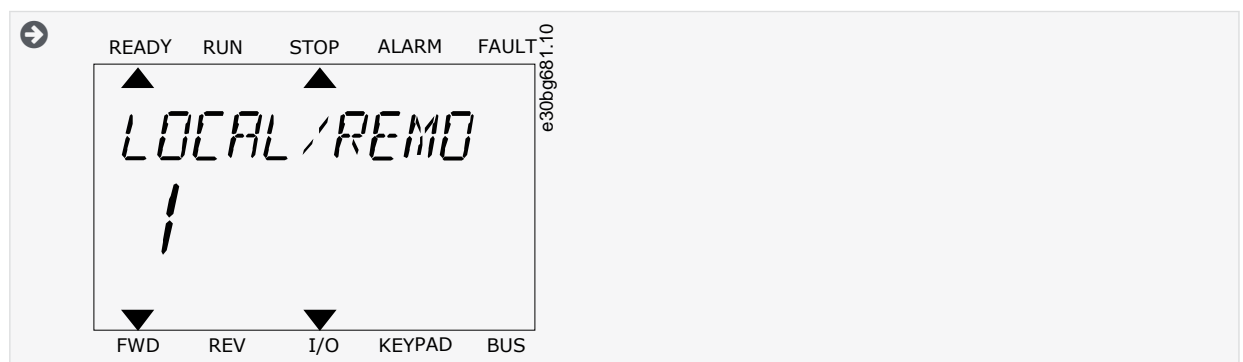

- To select *Local* or *Remote*, use the arrow buttons Up and Down again. To accept the selection, push the [OK] button.

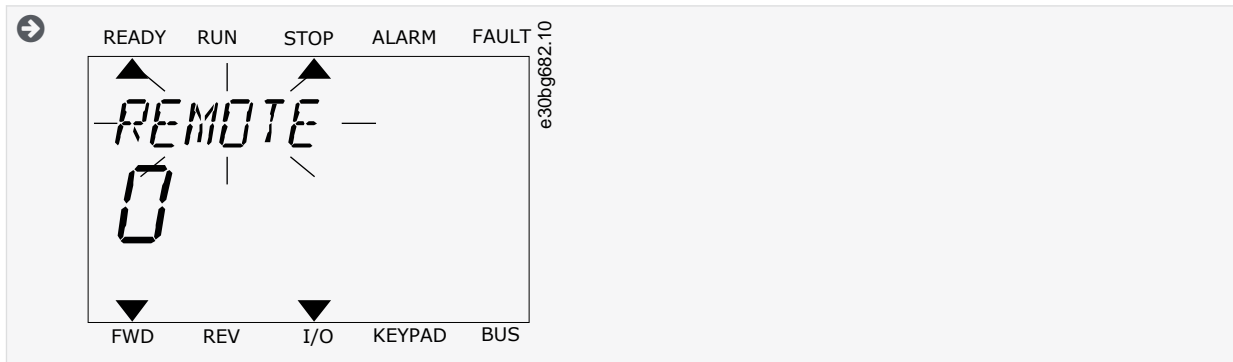

- If *Remote* control place is changed to *Local*, that is, the keypad, give a keypad reference.

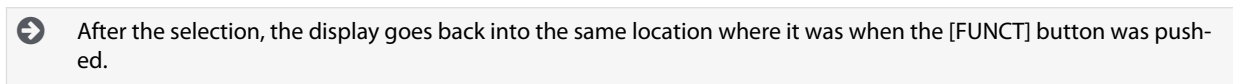

2.4.4.3 Going into the Control Page

It is easy to monitor the most important values in the *Control page*.

See more information about Keypad Reference in [6.3 Group 3.3: References](#). If other control places or reference values are used, the display shows the frequency reference that cannot be edited. The other values on the page are *Multimonitor* values. These values can be selected (see [5.2.1 Changing the Items to Monitor](#)).

Procedure

- Anywhere in the menu structure, push the [FUNCT] button.
- To select the *Control page*, push the arrow buttons Up and Down. Go in with the [OK] button.

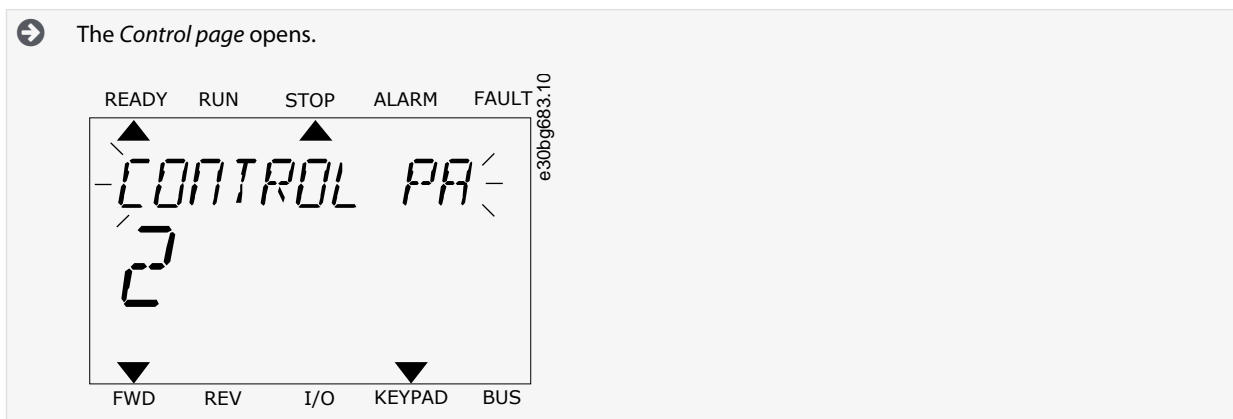

- If the *Local* control place and the keypad reference are used, P3.3.1.8 Keypad Reference can be set with the [OK] button.

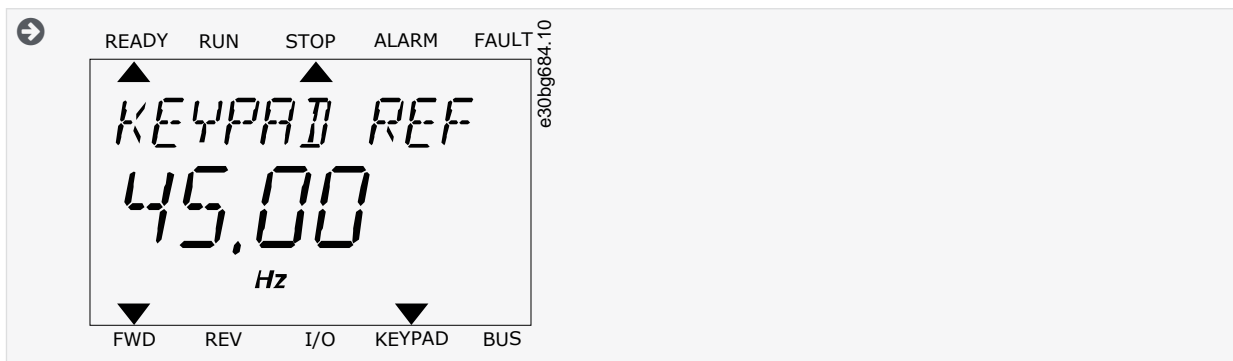

2.4.4.4 Changing the Rotation Direction

The rotation direction of the motor can be changed quickly with the [FUNCT] button.

NOTICE

The command *Change direction* is available in the menu only if the current control place is Local.

Procedure

1. Anywhere in the menu structure, push the [FUNCT] button.
2. To select *Change direction*, push the arrow buttons Up and Down. Push the [OK] button.
3. Select a new rotation direction.

➡ The current rotation direction blinks.

4. Push the [OK] button.

➡ The rotation direction changes immediately. The arrow indication in the status field of the display changes.

2.4.4.5 Using the Quick Edit Function

With the *Quick Edit* function, a parameter can be accessed quickly by typing the ID number of the parameter.

Procedure

1. Anywhere in the menu structure, push the [FUNCT] button.
2. Push the arrow buttons Up and Down to select *Quick Edit* and accept with the [OK] button.
3. Write the ID number of a parameter or monitoring value. Push [OK].

➡ The display shows the parameter value in the edit mode and the monitoring value in the monitoring mode.

2.5 VACON® Live PC Tool

VACON® Live is a PC tool for commissioning and maintenance of the VACON® AC drives. VACON® Live can be downloaded from <https://www.danfoss.com>.

The VACON® Live PC tool includes these functions.

- Parameterization, monitoring, drive info, data logger, and so on.
- The software download tool VACON® Loader
- Serial communication and Ethernet support
- Windows XP, Vista, 7, 8, and 10 support
- 17 languages: English, German, Spanish, Finnish, French, Italian, Russian, Swedish, Chinese, Czech, Danish, Dutch, Polish, Portuguese, Romanian, Slovak and Turkish

Make the connection between the AC drive and the PC tool with the VACON® serial communication cable. The serial communication drivers are installed automatically during the installation of VACON® Live. After the cable is installed, VACON® Live finds the connected drive automatically.

See more on how to use VACON® Live in the help menu of the program.

The screenshot shows the VACON Live 1.1.180 software interface. The main window is titled 'Parameter Browser' and displays a list of parameters organized into sections. The left sidebar shows a tree view of the parameter structure, including sections like '1. Quick Setup', '2.1. Multimonitor', '3. Parameters', and '3.1. Motor Settings'. The main area shows a table of parameters with columns for Index, Variable/Text, Value, Min, Max, Unit, Default, ID, and Help. The parameters are grouped into sections such as '1.1. Standard', '2.1. Multimonitor', and '3.1. Standard'. The status bar at the bottom shows 'I/O', 'Datalogger', 'Clockwise', 'Online', 'Ready', 'Run', 'Fault', 'Alarm', and '0'.

Index	Variable/Text	Value	Min	Max	Unit	Default	ID	Help
1. Quick Setup (29)								
P.1.2	Application	Standard	Standard	Motor Potentiometer	Standard	212		Use this parameter to select the application configuration for the drive.
P.1.3	MinFreqReference	0.00	0.00	50.00	Hz	0.00	101	Use this parameter to set the minimum frequency reference.
P.1.4	MaxFreqReference	50.00	0.00	320.00	Hz	0.00	102	Use this parameter to set the maximum frequency reference.
P.1.5	Accel Time 1	5.0	0.1	3000.0	s	5.0	103	Use this parameter to set the time that is necessary for the output frequency to increase from zero frequency to maximum frequency.
P.1.6	Decel Time 1	5.0	0.1	3000.0	s	5.0	104	Use this parameter to set the time that is necessary for the output frequency to decrease from maximum frequency to zero frequency.
P.1.7	Current Limit	3.70	0.26	5.20	A	0.00	107	Use this parameter to set the maximum motor current from the AC drive.
P.1.8	Motor Type	Induction Motor	Induction Motor	Reluctance Motor	Induction Motor	650		Use this parameter to set the type of motor in your process.
P.1.9	Motor Nom Voltg	230	180	240	V	0	110	Find the value Un on the nameplate of the motor.
P.1.10	Motor Nom Freq	50.00	8.00	320.00	Hz	0.00	111	Find the value fn on the nameplate of the motor.
P.1.11	Motor Nom Speed	1370	24	19200	rpm	0	112	Find the value n on the nameplate of the motor.
P.1.12	Motor Nom Currnt	1.90	0.26	5.20	A	0.00	113	Find the value In on the nameplate of the motor.
P.1.13	Motor Cos Phi	0.74	0.30	1.00		0.00	120	Find the value on the nameplate of the motor.
P.1.14	Energy Optimization	Disabled	Disabled	Enabled	Disabled	666		Use this parameter to enable the Energy Optimization function.
P.1.15	Identification	No Action	No Action	With Rotation	No Action	631		Use this parameter to find the parameter values that are optimal for the operation of the drive.
P.1.16	Start Function	Ramping	Ramping	Flving Start	Ramping	505		Use this parameter to select the type of the start function.
P.1.17	Stop Function	Coasting	Coasting	Ramping	Coasting	506		Use this parameter to select the type of the stop function.
P.1.18	Automatic Reset	Disabled	Disabled	Enabled	Disabled	731		Use this parameter to enable the Automatic reset function.
P.1.19	External Fault	Fault	No Action	Fault/Coast	Fault	701		Use this parameter to select the response of the drive to an 'External Fault'.
P.1.20	All Low Fault	No Action	No Action	Fault/Coast	No Action	700		Use this parameter to select the response of the drive to an 'All Low' fault.
P.1.21	Rem. Ctl. Place	I/O Control	I/O Control	FieldbusCTRL	I/O Control	172		Use this parameter to select the remote control place (start/stop).
P.1.22	I/O A Ref sel	A11+A12	Block Out.10	Block Out.10	A11+A12	117		Use this parameter to select the reference source when the control place is I/O A.
P.1.23	Keypad Ref Sel	Keypad Ref	PresetFreq0	Block Out.10	Keypad Ref	121		Use this parameter to select the reference source when the control place is keypad.
P.1.24	Fieldbus Ref Sel	Fieldbus	PresetFreq0	Block Out.10	Fieldbus	122		Use this parameter to select the reference source when the control place is Fieldbus.
P.1.25	A11 Signal Range	0-10V/0-20mA	0-10V/0-20mA	2-10V/4-20mA	0-10V/0-20mA	379		Use this parameter to change the range of the analogue signal.
P.1.26	A12 Signal Range	2-10V/4-20mA	0-10V/0-20mA	2-10V/4-20mA	2-10V/4-20mA	380		Use this parameter to change the range of the analogue signal.
P.1.27	RO1 Function	Run	Not Used	Selected Param.Set	Run	11001		Use this parameter to select a function or a signal that is connected to the relay output.
P.1.28	RO2 Function	Fault	Not Used	Selected Param.Set	Fault	11004		Use this parameter to select a function or a signal that is connected to the relay output.
P.1.29	RO3 Function	Ready	Not Used	Selected Param.Set	Ready	11007		Use this parameter to select a function or a signal that is connected to the relay output.
P.1.30	AO1 Function	Output Freq	0% TEST	Block Out.10	Output Freq	10050		Use this parameter to select a function or a signal that is connected to the analogue output.
1.31. Standard (1)								
P.1.31	Preset Freq 1	10.00	0.00	50.00	Hz	10.00	105	Use this parameter to set the preset frequency reference when the preset frequencies function is used.
P.1.31	Preset Freq 2	15.00	0.00	50.00	Hz	15.00	106	Use this parameter to set the preset frequency reference when the preset frequencies function is used.
P.1.31	Preset Freq 3	20.00	0.00	50.00	Hz	20.00	126	Use this parameter to set the preset frequency reference when the preset frequencies function is used.
2.1. Multimonitor (18)								
V.2.1:	FreqReference	9.06	-320.00	320.00	Hz	0.00	25	This monitoring value shows the actual frequency reference to the motor control.
V.2.1:	Output frequency	0.00	-320.00	320.00	Hz	0.00	1	This monitoring value shows the actual output frequency to the motor.
V.2.1:	Motor Current	0.00	0.00	5.20	A	0.00	3	This monitoring value shows the measured current of the motor.
V.2.1:	Motor Speed	0.0	-19200	19200	rpm	0.0	2	This monitoring value shows the actual speed of the motor in rpm (calculated value).
V.2.1:	Motor Torque	0.0	-3000.0	3000.0	%	0.0	4	This monitoring value shows the actual torque of the motor (calculated value).
V.2.1:	Motor Power	0.0	-3000.0	3000.0	%	0.0	5	This monitoring value shows the actual shaft power of the motor (calculated value) as a percentage of the motor nominal power.
V.2.1:	Motor Voltage	0.0	0.0	700.0	V	0.0	6	This monitoring value shows the actual output voltage to the motor.
V.2.1:	DC-link Voltage	329	0	1200	V	0	7	This monitoring value shows the measured voltage in the DC-link of the drive.
V.2.1:	Unit Temperature	21.0	-15.0	90.0	°C	0.0	8	This monitoring value shows the measured heatsink temperature of the drive.
2.3. Basic (18)								
V.2.3:	Output frequency	0.00	-320.00	320.00	Hz	0.00	1	This monitoring value shows the actual output frequency to the motor.
V.2.3:	FreqReference	9.06	-320.00	320.00	Hz	0.00	25	This monitoring value shows the actual frequency reference to the motor control.

e30bg685.10

Illustration 5: The VACON® Live PC Tool

3 Applications

3.1 Using the Applications

Use the parameter P1.2 (Application) to select an application for the drive. Immediately when the parameter P1.2 changes, parameter groups get their preset values.

3.2 Standard and HVAC Applications

Use the Standard and HVAC applications to control pumps or fans, for example.

It is possible to control the drive from the control panel (keypad), Fieldbus, or I/O terminal.

When the drive is controlled with the I/O terminal, the frequency reference signal is connected to AI1 (0...10 V) or AI2 (4...20 mA). The connection depends on the type of the signal. There are also 3 preset frequency references available. The preset frequency references can be activated with DI4 and DI5. The start/stop signals of the drive are connected to DI1 (start forward) and DI2 (start reverse).

It is possible to configure all the drive outputs freely in all the applications. There is 1 analog output (Output Frequency) and 3 relay outputs (Run, Fault, Ready) available on the basic I/O board.

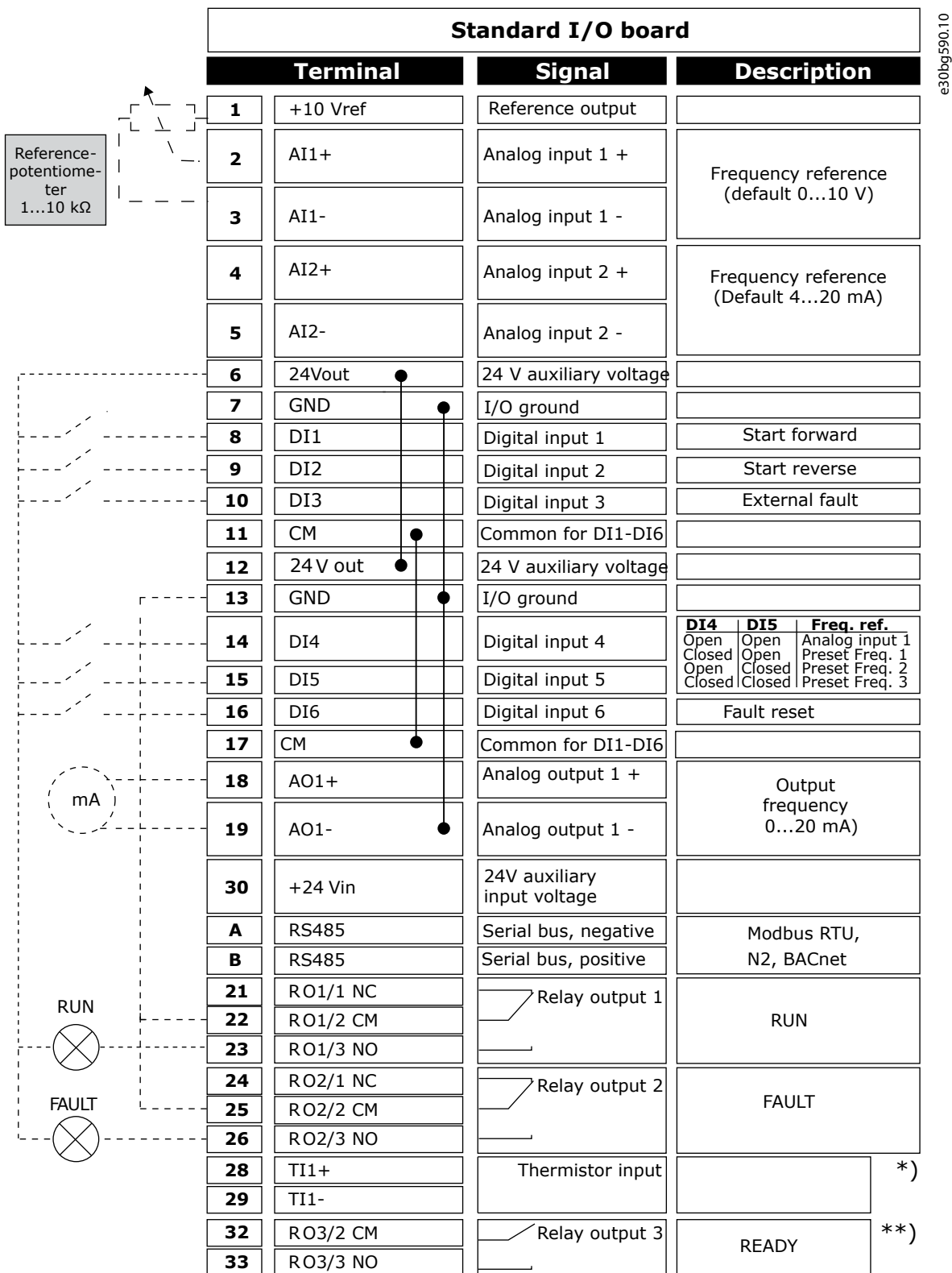

Illustration 6: The Default Control Connections of the Standard and HVAC Applications

*) Available only in VACON® 100 X. **) For the DIP switch configurations in VACON® 100 X, see the VACON® 100 X Installation manual.

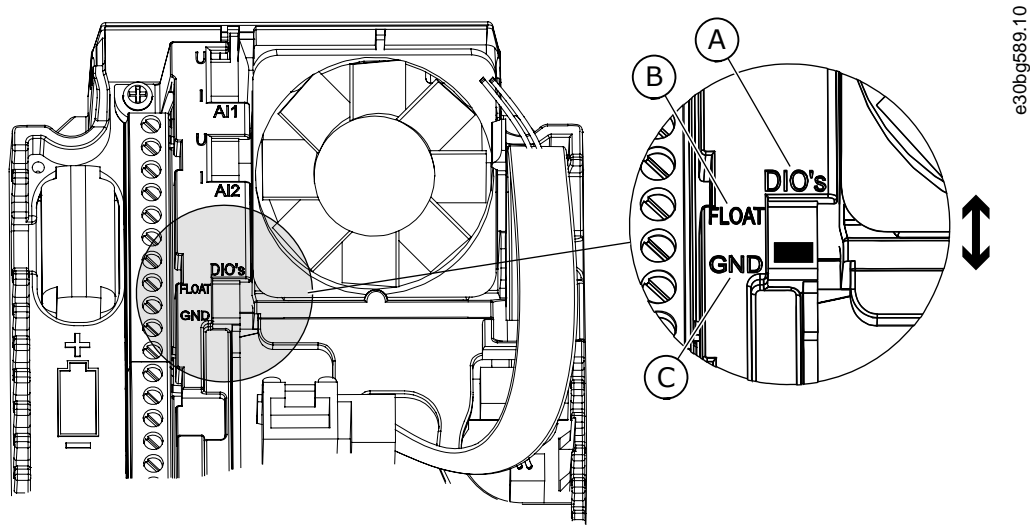

Illustration 7: The DIP Switch

A	Digital input DIP switch	C	Connected to GND (Default)
B	Floating		

See information on the Startup, and Fire mode wizards in [4.2.1 Wizards in Menu 1.1](#).

Table 3: M1 Quick Setup

Index	Parameter	Min	Max	Unit	Default	ID	Description
1.2	Application	0	4		0	212	0 = Standard 1 = HVAC 2 = PID Control 3 = Multi-pump (single drive) 4 = Multi-pump (multidrive)
1.3	Minimum Frequency Reference	0.00	P1.4	Hz	0.0	101	
1.4	Maximum Frequency Reference	P1.3	320.0	Hz	50.0/60.0	102	
1.5	Acceleration Time 1	0.1	3000.0	s	5.0	103	
1.6	Deceleration Time 1	0.1	3000.0	s	5.0	104	
1.7	Motor Current Limit	I _H *0.1	I _S	A	Varies	107	
1.8	Motor Type	0	2		0	650	0 = Induction Motor 1 = Permanent Magnet Motor 2 = Reluctance Motor
1.9	Motor Nominal Voltage	Varies	Varies	V	Varies	110	Find this value U _n on the nameplate of the motor. NOTE! Find out if the motor connection is Delta or Star.
1.10	Motor Nominal Frequency	8.0	320.0	Hz	50/60	111	Find this value f _n on the nameplate of the motor.

Index	Parameter	Min	Max	Unit	Default	ID	Description
1.11	Motor Nominal Speed	24	19200	RPM	Varies	112	Find this value n_n on the nameplate of the motor.
1.12	Motor Nominal Current	IH * 0.1	IH * 2	A	Varies	113	Find this value I_n on the nameplate of the motor.
1.13	Motor Cos Phi (Power Factor)	0.30	1.00		Varies	120	Find this value on the nameplate of the motor.
1.14	Energy Optimization	0	1		0	666	0 = Disabled 1 = Enabled
1.15	Identification	0	2		0	631	0 = No action 1 = At standstill 2 = With rotation
1.16	Start Function	0	1		0	505	0 = Ramping 1 = Flying Start
1.17	Stop Function	0	1		0	506	0 = Coasting 1 = Ramping
1.18	Automatic Reset	0	1		0	731	0 = Disabled 1 = Enabled
1.19	Response to External Fault	0	3		2	701	0 = No action 1 = Alarm 2 = Fault (Stop according to stop mode) 3 = Fault (Stop by coasting)
1.20	Response to AI Low Fault	0	5		0	700	0 = No action 1 = Alarm 2 = Alarm+preset fault frequency (P3.9.1.13) 3 = Alarm + previous frequency 4 = Fault (Stop according to stop mode) 5 = Fault (Stop by coasting)
1.21	Remote Control Place	0	1		0	172	0 = I/O control 1 = Fieldbus control
1.22	I/O Control Reference A Selection	1	20		5	117	1 = Preset Frequency 0 2 = Keypad reference 3 = Fieldbus 4 = AI1 5 = AI2 6 = AI1+AI2 7 = PID reference 8 = Motor potentiometer 11 = Block Out.1 12 = Block Out.2 13 = Block Out.3 14 = Block Out.4 15 = Block Out.5

Index	Parameter	Min	Max	Unit	Default	ID	Description
							16 = Block Out.6 17 = Block Out.7 18 = Block Out.8 19 = Block Out.9 20 = Block Out.10
1.23	Keypad Control Reference Selection	1	20		1	121	See P1.22.
1.24	Fieldbus Control Reference Selection	1	20		2	122	See P1.22.
1.25	AI1 Signal Range	0	1		0	379	0= 0...10 V/0...20 mA 1= 2...10 V/4...20 mA
1.26	AI2 Signal Range	0	1		1	390	0= 0...10 V/0...20 mA 1= 2...10 V/4...20 mA
1.27	RO1 Function	0	74		2	11001	See P3.5.3.2.1.
1.28	RO2 Function	0	74		3	11004	See P3.5.3.2.1.
1.29	RO3 Function	0	74		1	11007	See P3.5.3.2.1.
1.30	AO1 Function	0	31		2	10050	See P3.5.4.1.1.

Table 4: M1.31 Standard/M1.32 HVAC

Index	Parameter	Min	Max	Unit	Default	ID	Description
1.31.1	Preset Frequency 1	P1.3	P1.4	Hz	10.0	105	
1.31.2	Preset Frequency 2	P1.3	P1.4	Hz	15.0	106	
1.31.3	Preset Frequency 3	P1.3	P1.4	Hz	20.0	126	

3.3 PID Control Application

Use the PID control application with processes where the process variable (for example pressure) is controlled through control of the speed of the motor.

In this application, the internal PID controller of the drive is configured for 1 setpoint and 1 feedback signal.

It is possible to use 2 control places. Make the selection of the control place A or B with DI6. When control place A is active, the start/stop commands are given by DI1, and the PID controller gives the frequency reference. When control place B is active, start/stop commands are given by DI4, and AI1 gives the frequency reference.

It is possible to configure all the drive outputs freely in all the applications. There are 1 analog output (Output Frequency) and 3 relay outputs (Run, Fault, Ready) available on the basic I/O board.

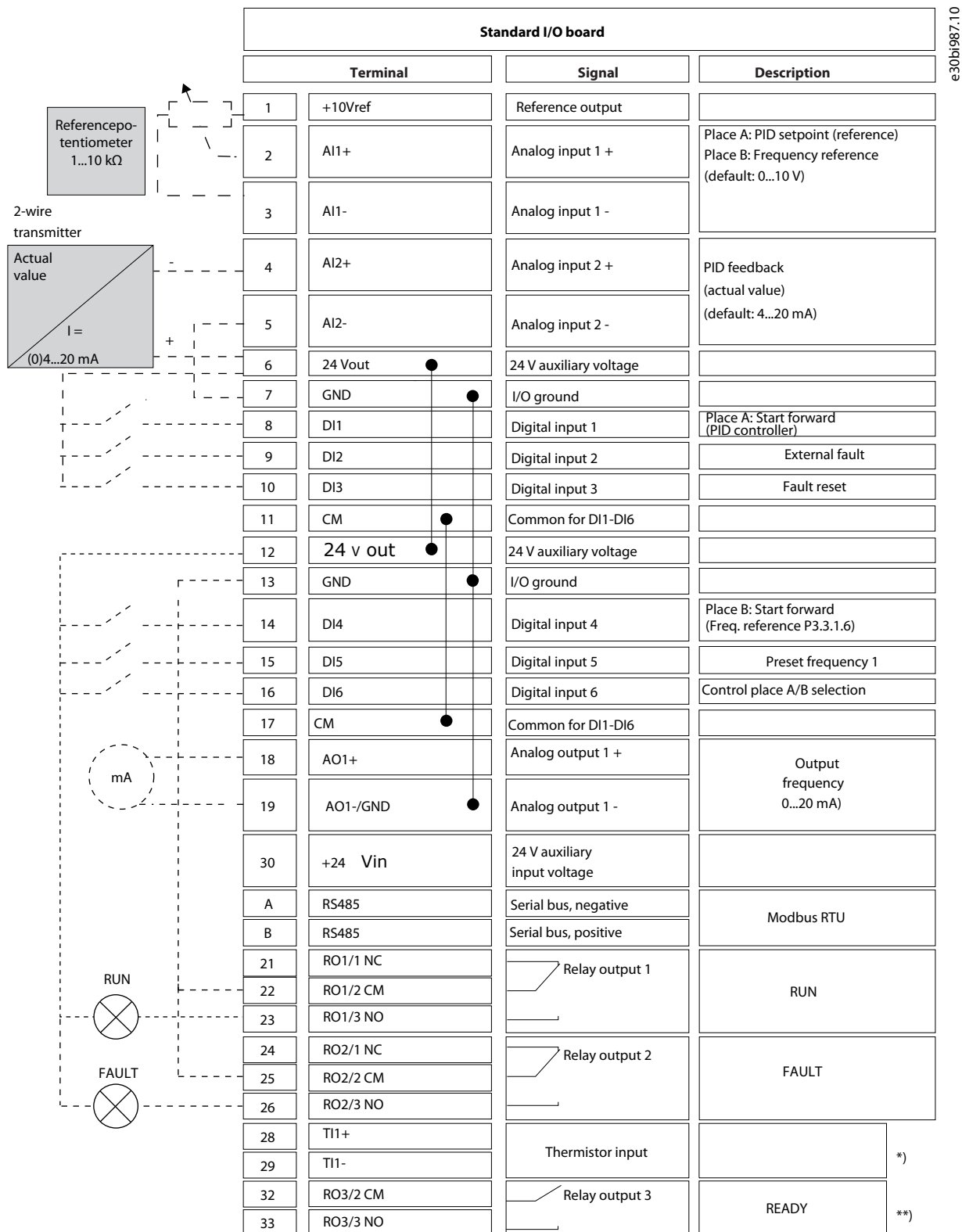

Illustration 8: The Default Control Connections of the PID Control Application

*) Available only in VACON® 100 X. **) For the DIP switch configurations in VACON® 100 X, see the VACON® 100 X Installation manual.

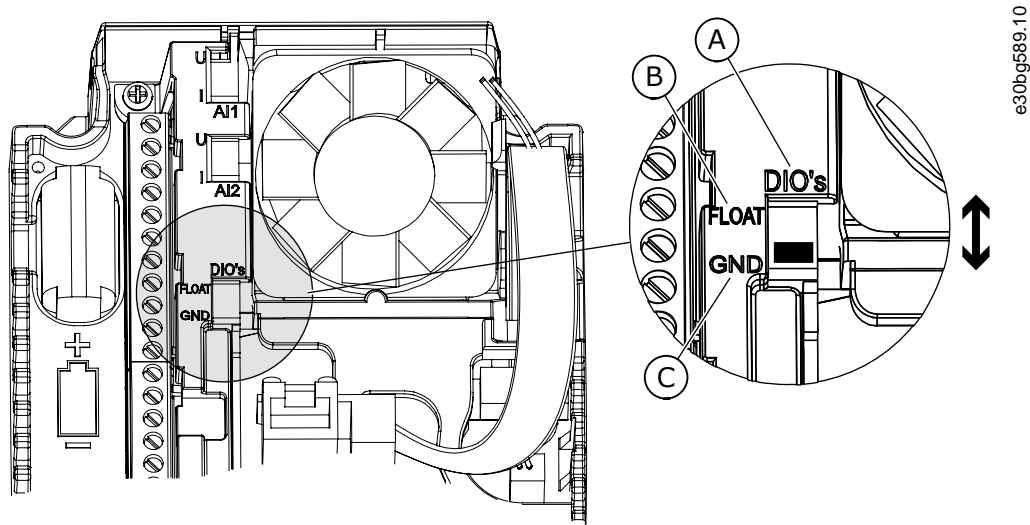

Illustration 9: The DIP Switch

A	Digital input DIP switch	C	Connected to GND (Default)
B	Floating		

See information on the Startup, and Fire mode wizards in [4.2.1 Wizards in Menu 1.1](#).

Table 5: M1 Quick Setup

Index	Parameter	Min	Max	Unit	Default	ID	Description
1.2	Application	0	4		2	212	0 = Standard 1 = HVAC 2 = PID Control 3 = Multi-pump (single drive) 4 = Multi-pump (multidrive)
1.3	Minimum Frequency Reference	0.00	P1.4	Hz	0.0	101	
1.4	Maximum Frequency Reference	P1.3	320.0	Hz	50.0/60.0	102	
1.5	Acceleration Time 1	0.1	3000.0	s	5.0	103	
1.6	Deceleration Time 1	0.1	3000.0	s	5.0	104	
1.7	Motor Current Limit	I _H *0.1	I _S	A	Varies	107	
1.8	Motor Type	0	2		0	650	0 = Induction Motor 1 = Permanent Magnet Motor 2 = Reluctance Motor
1.9	Motor Nominal Voltage	Varies	Varies	V	Varies	110	Find this value U _n on the nameplate of the motor. NOTE! Find out if the motor connection is Delta or Star.
1.10	Motor Nominal Frequency	8.0	320.0	Hz	50/60	111	Find this value f _n on the nameplate of the motor.

Index	Parameter	Min	Max	Unit	Default	ID	Description
1.11	Motor Nominal Speed	24	19200	RPM	Varies	112	Find this value n_n on the nameplate of the motor.
1.12	Motor Nominal Current	IH * 0.1	IH * 2	A	Varies	113	Find this value I_n on the nameplate of the motor.
1.13	Motor Cos Phi (Power Factor)	0.30	1.00		Varies	120	Find this value on the nameplate of the motor.
1.14	Energy Optimization	0	1		0	666	0 = Disabled 1 = Enabled
1.15	Identification	0	2		0	631	0 = No action 1 = At standstill 2 = With rotation
1.16	Start Function	0	1		0	505	0 = Ramping 1 = Flying Start
1.17	Stop Function	0	1		0	506	0 = Coasting 1 = Ramping
1.18	Automatic Reset	0	1		0	731	0 = Disabled 1 = Enabled
1.19	Response to External Fault	0	3		2	701	0 = No action 1 = Alarm 2 = Fault (Stop according to stop mode) 3 = Fault (Stop by coasting)
1.20	Response to AI Low Fault	0	5		0	700	0 = No action 1 = Alarm 2 = Alarm+preset fault frequency (P3.9.1.13) 3 = Alarm + previous frequency 4 = Fault (Stop according to stop mode) 5 = Fault (Stop by coasting)
1.21	Remote Control Place	0	1		0	172	0 = I/O control 1 = Fieldbus control
1.22	I/O Control Reference A Selection	1	20		6	117	1 = Preset Frequency 0 2 = Keypad reference 3 = Fieldbus 4 = AI1 5 = AI2 6 = AI1+AI2 7 = PID reference 8 = Motor potentiometer 11 = Block Out.1 12 = Block Out.2 13 = Block Out.3 14 = Block Out.4 15 = Block Out.5

Index	Parameter	Min	Max	Unit	Default	ID	Description
							16 = Block Out.6 17 = Block Out.7 18 = Block Out.8 19 = Block Out.9 20 = Block Out.10
1.23	Keypad Control Reference Selection	1	20		1	121	See P1.22.
1.24	Fieldbus Control Reference Selection	1	20		2	122	See P1.22.
1.25	AI1 Signal Range	0	1		0	379	0= 0...10 V/0...20 mA 1= 2...10 V/4...20 mA
1.26	AI2 Signal Range	0	1		1	390	0= 0...10 V/0...20 mA 1= 2...10 V/4...20 mA
1.27	RO1 Function	0	74		2	11001	See P3.5.3.2.1.
1.28	RO2 Function	0	74		3	11004	See P3.5.3.2.1.
1.29	RO3 Function	0	74		1	11007	See P3.5.3.2.1.
1.30	AO1 Function	0	31		2	10050	See P3.5.4.1.1.

Table 6: M1.33 PID Control

Index	Parameter	Min	Max	Unit	Default	ID	Description
1.33.1	PID Gain	0.00	100.00	%	100.00	118	
1.33.2	PID Integration Time	0.00	600.00	s	1.00	119	
1.33.3	PID Derivation Time	0.00	100.00	s	0.00	132	
1.33.4	Process Unit Selection	1	44		1	1036	See P3.13.1.4
1.33.5	Process Unit Min	Varies	Varies		Varies	1033	See P3.13.2.6.
1.33.6	Process Unit Max	Varies	Varies		Varies	1034	
1.33.7	Feedback 1 Source Selection	0	30		2	334	See P3.13.3.3
1.33.8	Setpoint 1 Source Selection	0	32		1	332	See P3.13.2.6
1.33.9	Keypad Setpoint 1	Varies	Varies	Varies	0	167	
1.33.10	SP1 Sleep Frequency Limit	0.0	320.0	Hz	0.0	1016	
1.33.11	SP1 Sleep Delay	0	3000	s	0	1017	0 = Not used
1.33.12	SP1 Wake Up Level	Varies	Varies	Varies	Varies	1018	0 = Not used
1.33.13	Preset Frequency 1	P1.3	P1.4	Hz	10.0	105	

3.4 Multi-pump (Single Drive) Application

Use the Multi-pump (single drive) application in applications, where 1 drive controls a system that has the maximum of 8 parallel motors, for example, pumps, fans or compressors. By default, Multi-pump (single drive) application is configured for 3 parallel motors.

The drive is connected to 1 of the motors, which becomes the regulating motor. The internal PID controller of the drive controls the speed of the regulating motor and gives control signals by relay outputs to start or stop the auxiliary motors. External contactors (switch) set the auxiliary motors to the mains.

It is possible to control a process variable, the pressure, for example, by the control of the speed of the regulating motor and by the number of motors that operate.

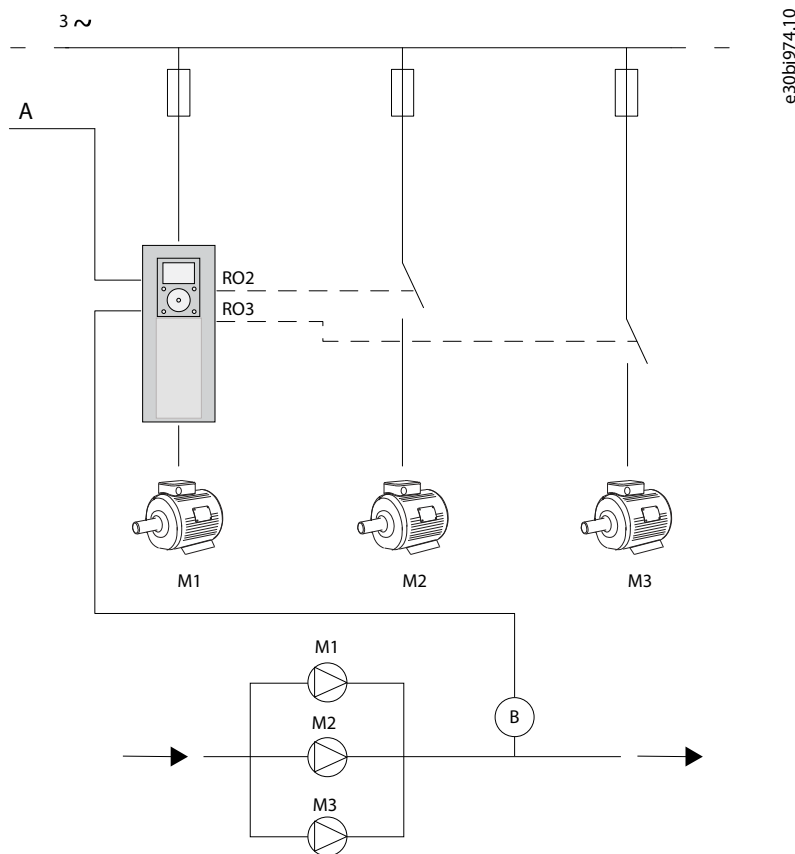

Illustration 10: Multi-pump (Single Drive) Configuration

- | | |
|---|-----------------|
| A | Start / Stop |
| B | Pressure sensor |

Autochange function (change of start order) makes the wear of the motors in the system more equal. Autochange function monitors the running hours and sets the start order of each motor. The motor that has the lowest running hours starts first and the motor that has the highest running hours starts last. It is possible to configure the autochange to start based on the autochange interval time set by the internal real-time clock (an RTC battery needed) of the drive.

It is possible to configure the autochange for all the motors in the system or only the auxiliary motors.

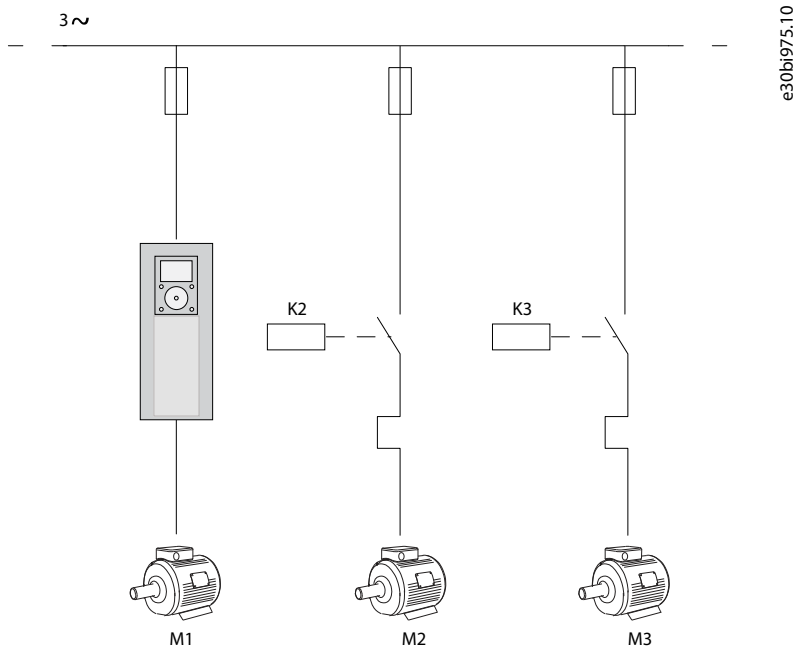

Illustration 11: Control Diagram with Only the Auxiliary Motors Configured to Autochange

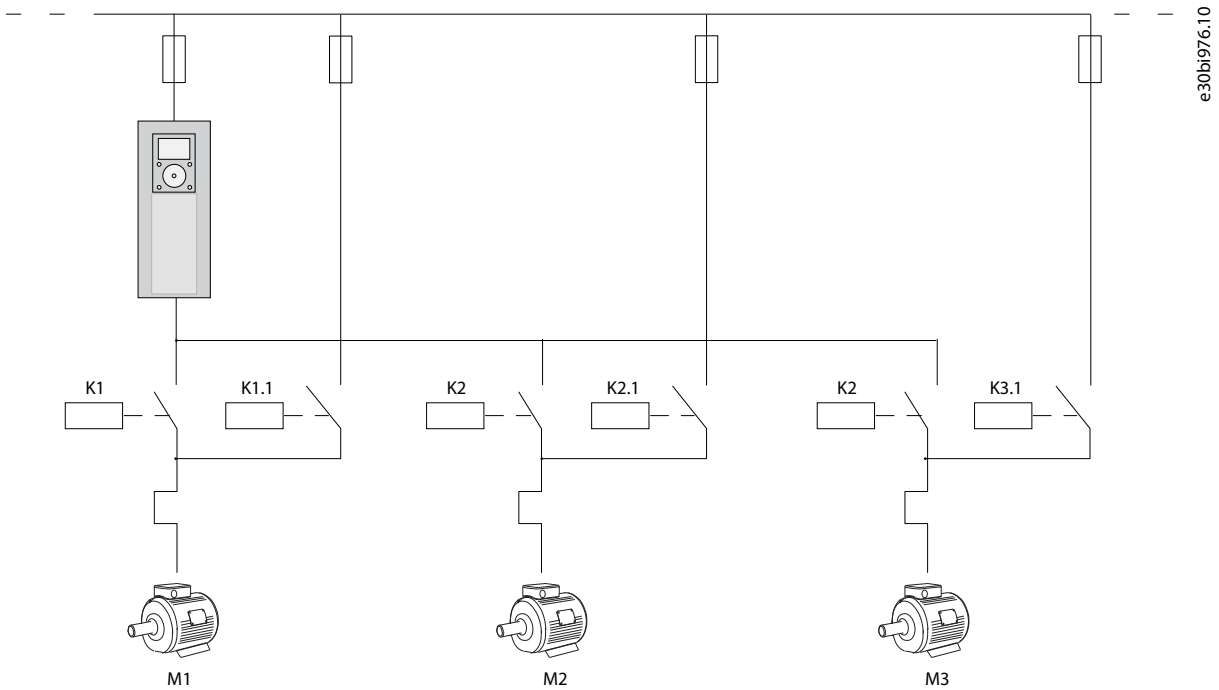

Illustration 12: Control Diagram with All the Motors Configured to Autochange

It is possible to use 2 control places. Make the selection of the control place A or B with DI6. When control place A is active, DI1 gives the start and stop commands, and the PID controller gives the frequency reference. When control place B is active, DI4 gives the start and stop commands, and AI1 gives the frequency reference.

It is possible to configure all the drive outputs freely in all the applications. There is 1 analog output (Output Frequency) and 3 relay outputs (Run, Fault, Ready) available on the basic I/O board.

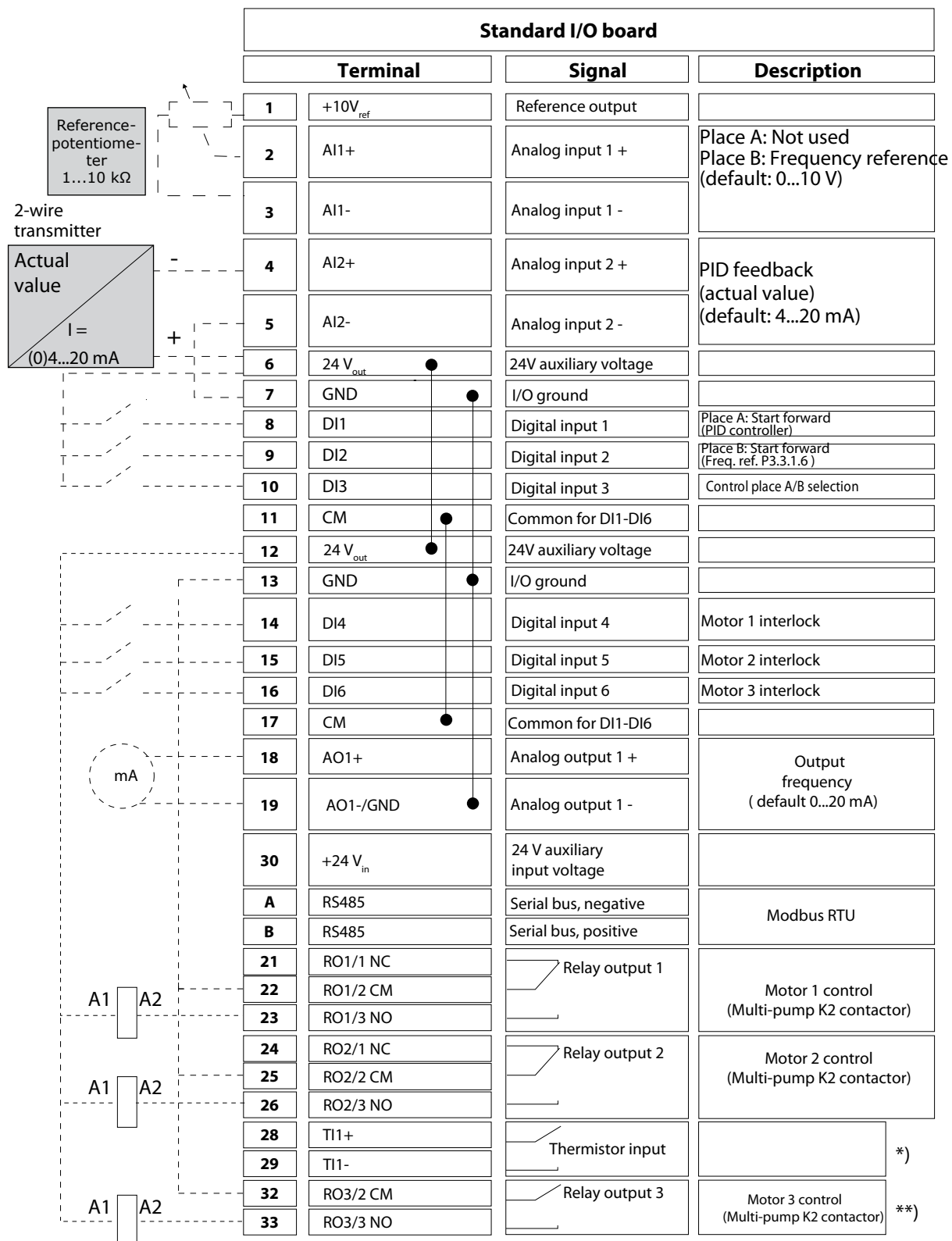

Illustration 13: The Default Control Connections of the Multi-pump (Single Drive) Application

*) Available only in VACON® 100 X. **) For the DIP switch configurations in VACON® 100 X, see the VACON® 100 X Installation manual.

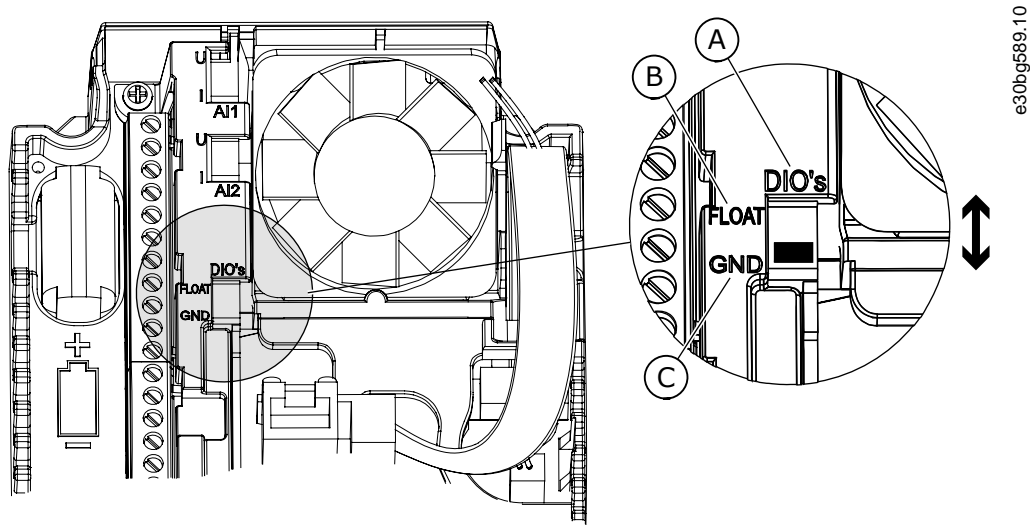

Illustration 14: The DIP Switch

A	Digital input DIP switch	C	Connected to GND (Default)
B	Floating		

See information on the Startup, and Fire mode wizards in [4.2.1 Wizards in Menu 1.1](#).

Table 7: M1 Quick Setup

Index	Parameter	Min	Max	Unit	Default	ID	Description
1.2	Application	0	4		2	212	0 = Standard 1 = HVAC 2 = PID Control 3 = Multi-pump (single drive) 4 = Multi-pump (multidrive)
1.3	Minimum Frequency Reference	0.00	P1.4	Hz	0.0	101	
1.4	Maximum Frequency Reference	P1.3	320.0	Hz	50.0/60.0	102	
1.5	Acceleration Time 1	0.1	3000.0	s	5.0	103	
1.6	Deceleration Time 1	0.1	3000.0	s	5.0	104	
1.7	Motor Current Limit	I _H *0.1	I _S	A	Varies	107	
1.8	Motor Type	0	2		0	650	0 = Induction Motor 1 = Permanent Magnet Motor 2 = Reluctance Motor
1.9	Motor Nominal Voltage	Varies	Varies	V	Varies	110	Find this value U _n on the nameplate of the motor. NOTE! Find out if the motor connection is Delta or Star.
1.10	Motor Nominal Frequency	8.0	320.0	Hz	50/60	111	Find this value f _n on the nameplate of the motor.

Index	Parameter	Min	Max	Unit	Default	ID	Description
1.11	Motor Nominal Speed	24	19200	RPM	Varies	112	Find this value n_n on the nameplate of the motor.
1.12	Motor Nominal Current	IH * 0.1	IH * 2	A	Varies	113	Find this value I_n on the nameplate of the motor.
1.13	Motor Cos Phi (Power Factor)	0.30	1.00		Varies	120	Find this value on the nameplate of the motor.
1.14	Energy Optimization	0	1		0	666	0 = Disabled 1 = Enabled
1.15	Identification	0	2		0	631	0 = No action 1 = At standstill 2 = With rotation
1.16	Start Function	0	1		0	505	0 = Ramping 1 = Flying Start
1.17	Stop Function	0	1		0	506	0 = Coasting 1 = Ramping
1.18	Automatic Reset	0	1		0	731	0 = Disabled 1 = Enabled
1.19	Response to External Fault	0	3		2	701	0 = No action 1 = Alarm 2 = Fault (Stop according to stop mode) 3 = Fault (Stop by coasting)
1.20	Response to AI Low Fault	0	5		0	700	0 = No action 1 = Alarm 2 = Alarm+preset fault frequency (P3.9.1.13) 3 = Alarm + previous frequency 4 = Fault (Stop according to stop mode) 5 = Fault (Stop by coasting)
1.21	Remote Control Place	0	1		0	172	0 = I/O control 1 = Fieldbus control
1.22	I/O Control Reference A Selection	1	20		6	117	1 = Preset Frequency 0 2 = Keypad reference 3 = Fieldbus 4 = AI1 5 = AI2 6 = AI1+AI2 7 = PID reference 8 = Motor potentiometer 11 = Block Out.1 12 = Block Out.2 13 = Block Out.3 14 = Block Out.4 15 = Block Out.5

Index	Parameter	Min	Max	Unit	Default	ID	Description
							16 = Block Out.6 17 = Block Out.7 18 = Block Out.8 19 = Block Out.9 20 = Block Out.10
1.23	Keypad Control Reference Selection	1	20		1	121	See P1.22.
1.24	Fieldbus Control Reference Selection	1	20		2	122	See P1.22.
1.25	AI1 Signal Range	0	1		0	379	0= 0...10 V/0...20 mA 1= 2...10 V/4...20 mA
1.26	AI2 Signal Range	0	1		1	390	0= 0...10 V/0...20 mA 1= 2...10 V/4...20 mA
1.27	RO1 Function	0	74		2	11001	See P3.5.3.2.1.
1.28	RO2 Function	0	74		3	11004	See P3.5.3.2.1.
1.29	RO3 Function	0	74		1	11007	See P3.5.3.2.1.
1.30	AO1 Function	0	31		2	10050	See P3.5.4.1.1.

Table 8: M1.34 Multi-pump (Single Drive)

Index	Parameter	Min	Max	Unit	Default	ID	Description
1.34.1	PID Gain	0.00	100.00	%	100.00	118	
1.34.2	PID Integration Time	0.00	600.00	s	1.00	119	
1.34.3	PID Derivation Time	0.00	100.00	s	0.00	132	
1.34.4	Process Unit Selection	1	44		1	1036	See P3.13.1.4
1.34.5	Process Unit Min	Varies	Varies		Varies	1033	
1.34.6	Process Unit Max	Varies	Varies		Varies	1034	
1.34.7	Feedback 1 Source Selection	0	30		2	334	See P3.13.3.3
1.34.8	Setpoint 1 Source Selection	0	32		1	332	See P3.13.2.6
1.34.9	Keypad Setpoint 1	Varies	Varies	Varies	0	167	
1.34.10	SP1 Sleep Frequency Limit	0.0	320.0	Hz	0.0	1016	
1.34.11	SP1 Sleep Delay	0	3000	s	0	1017	0 = Not used
1.34.12	SP1 Wake Up Level	Varies	Varies	Varies	Varies	1018	0 = Not used
1.34.13	Multi-pump Mode	0	2		0	1785	0= Single drive 1= Multifollower 2= Multimaster
1.34.14	Number of Pumps	1	8		1	1001	
1.34.15	Pump Interlocking	0	1		1	1032	0 = Disabled

Index	Parameter	Min	Max	Unit	Default	ID	Description
							1 = Enabled
1.34.16	Autochange	0	2		1	1027	0 = Disabled 1 = Enabled (interval) 2 = Enabled (weekdays)
1.34.17	Autochanged Pump	0	1		1	1028	0 = Auxiliary Pump 1 = All Pumps
1.34.18	Autochange Interval	0.0	3000.0	h	48.0	1029	
1.34.19	Autochange Days	0	127			15904	B0 = Sunday B1 = Monday B2 = Tuesday B3 = Wednesday B4 = Thursday B5 = Friday B6 = Saturday
1.34.20	Autochange Time of Day	00:00:00	23:59:59	Time		15905	Range: 00:00:00-23:59:59
1.34.21	Autochange: Frequency Limit	0.00	P3.3.1.2	Hz	25:00	1031	
1.34.22	Autochange: Pump Limit	1	4			1030	
1.34.23	Bandwidth	0	100	%	10	1097	
1.34.24	Bandwidth Delay	0	3600	s	10	1098	
1.34.25	Pump 1 Interlock				DigIN Slot0.1	426	OPEN = Not active CLOSED = Active
1.34.26	Pump 2 Interlock				DigIN Slot0.1	427	See 1.34.25
1.34.27	Pump 3 Interlock				DigIN Slot0.1	428	See 1.34.25
1.34.28	Pump 4 Interlock				DigIN Slot0.1	429	See 1.34.25
1.34.29	Pump 5 Interlock				DigIN Slot0.1	430	See 1.34.25
1.34.30	Pump 6 Interlock				DigIN Slot0.1	486	See 1.34.25
1.34.31	Pump 7 Interlock				DigIN Slot0.1	487	See 1.34.25
1.34.32	Pump 8 Interlock				DigIN Slot0.1	488	See 1.34.25

3.5 Multi-pump (Multidrive) Application

Use the Multi-pump (multidrive) application in a system that has the maximum of 8 parallel speed motors with different speeds, for example, pumps, fans or compressors. By default, the Multi-pump (Multidrive) application is configured for 3 parallel motors.

The checklist for the commissioning a Multi-pump (multidrive) system is in [11.17.1.1 Commissioning Multi-pump \(Multidrive\)](#).

Each motor has a drive controls that applicable motor. The drives of the system communicate with each other by Modbus RTU communication.

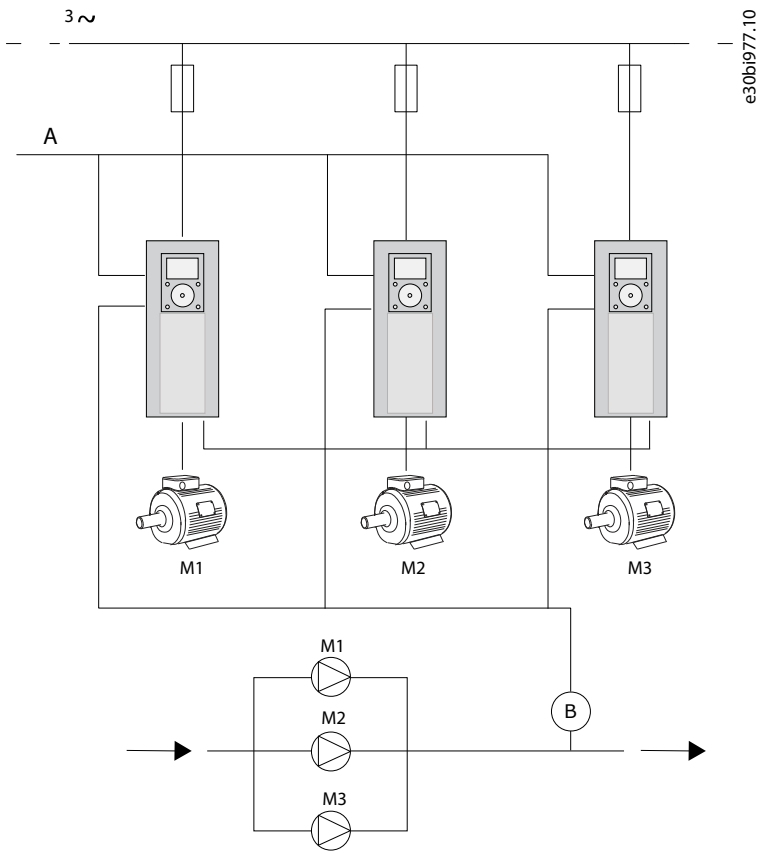

Illustration 15: Multi-pump (Multidrive) Configuration

A	Start / Stop
B	Pressure sensor

It is possible to control a process variable, the pressure, for example, by the control of the speed of the regulating motor and by the number of motors that operate. The internal PID controller in the drive of the regulating motor controls the speed, the start and stop of the motors.

The selected operation mode specifies the operation of the system. In the Multifollower mode, auxiliary motors follow the speed of the regulating motor.

Pump 1 controls and pumps 2 and 3 follow the speed of pump 1, as the curves A show.

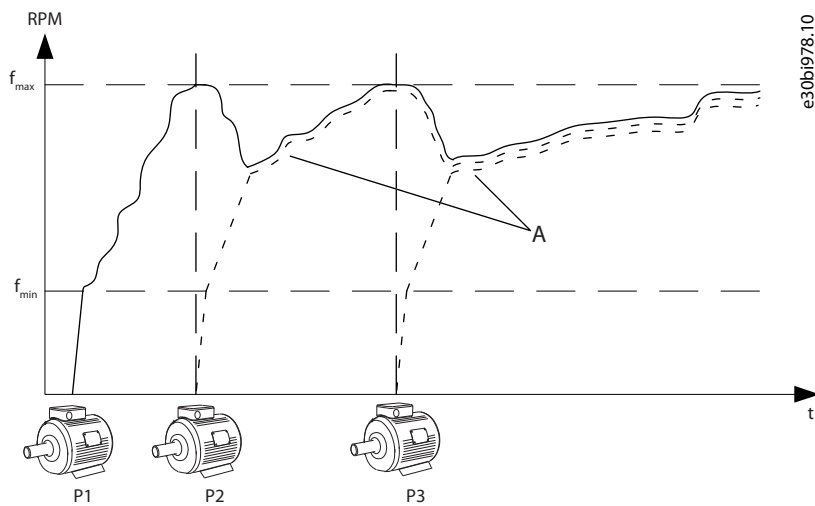

Illustration 16: Control in the Multifollower Mode

The figure [Illustration 17](#) shows an example of the Multimaster mode, where the speed of the regulating motor locks to the constant production speed B, when next motor starts. Curves A show the regulating of the pumps.

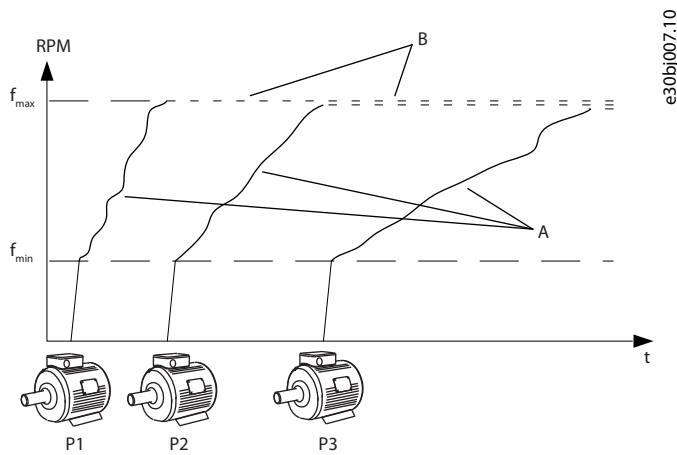

Illustration 17: Control in the Multimaster Mode

- | | |
|---|---|
| A | Curves A show the control of the pumps |
| B | The pumps are locked to the constant production frequency |

Autochange function (change of start order) makes the wear of the motors in the system more equal. Autochange function monitors the running hours and sets the start order of each motor. The motor that has the lowest running hours starts first and the motor that has the highest running hours starts last. It is possible to configure the autochange to start based on the autochange interval time or on the internal real-time clock of the drive (an RTC battery needed).

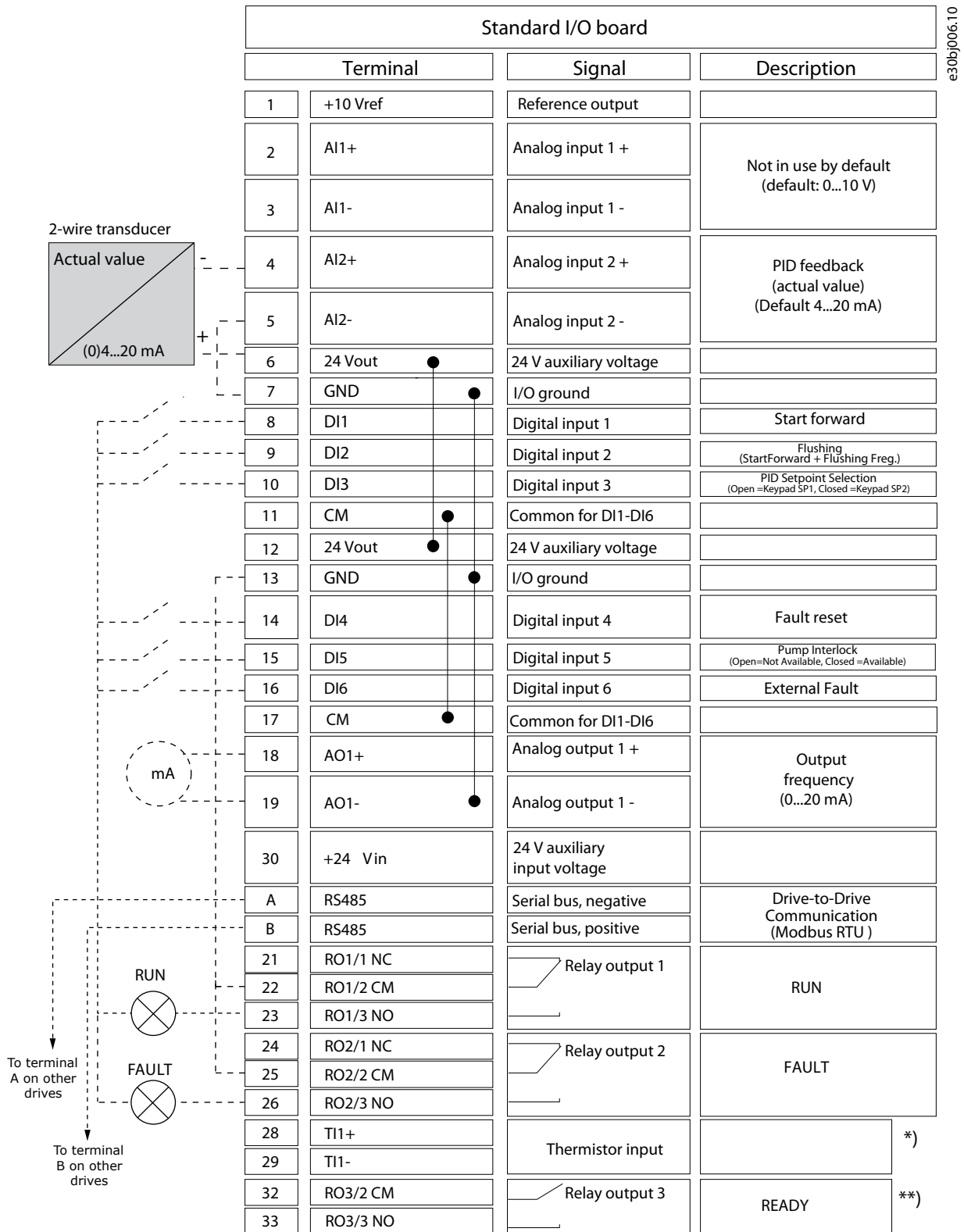

Illustration 18: The Default Control Connections of the Multi-pump (Multidrive) Application

*) Available only in VACON® 100 X. **) For the DIP switch configurations in VACON® 100 X, see the VACON® 100 X Installation manual.

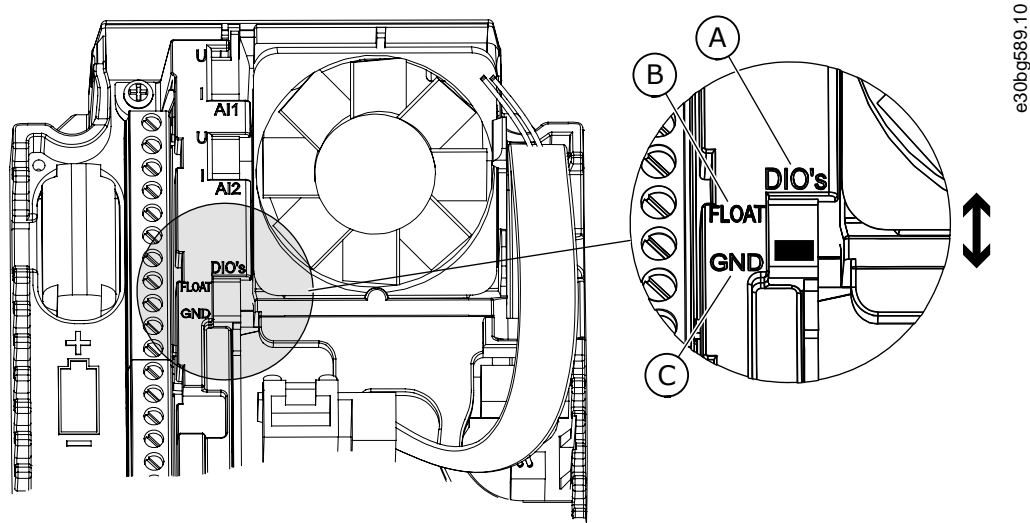

Illustration 19: The DIP Switch

<p>A Digital input DIP switch</p>	<p>C Connected to GND (Default)</p>
<p>B Floating</p>	

Each drive has a pressure sensor. When the redundancy level is high, the drive and the pressure sensors are redundant.

- If there is a drive failure, the next drive starts to operate as master.
- If there is a sensor failure, the next drive (that has a separate sensor) starts to operate as master.

An individual switch that has an auto, off and man setting controls each drive.

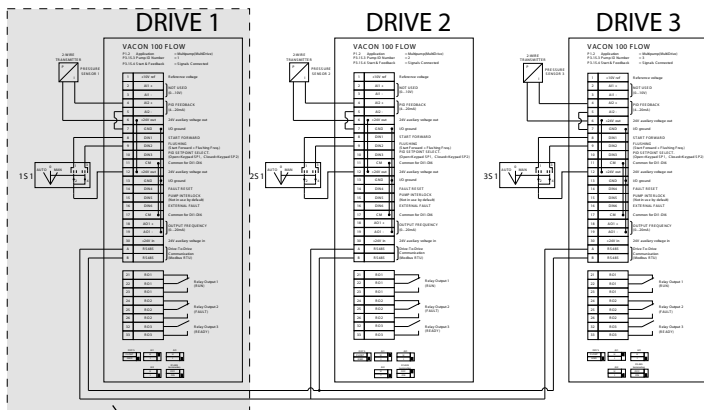

e30bi990.10

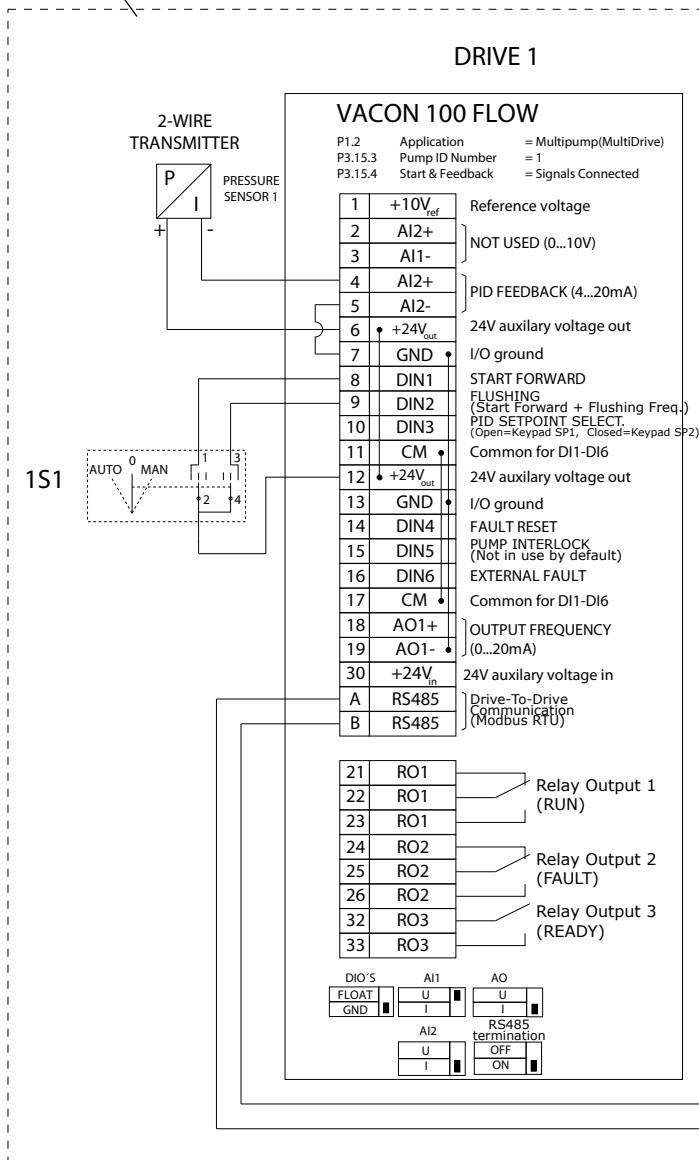
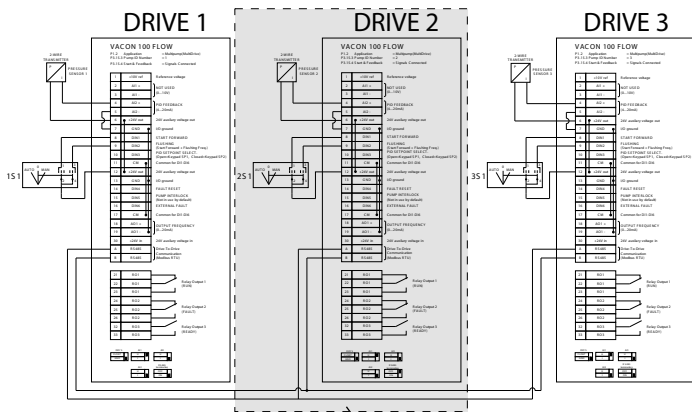

Illustration 20: Electric Wiring Diagram of the Multi-pump (Multidrive) System, Example 1A



e30b1991.10

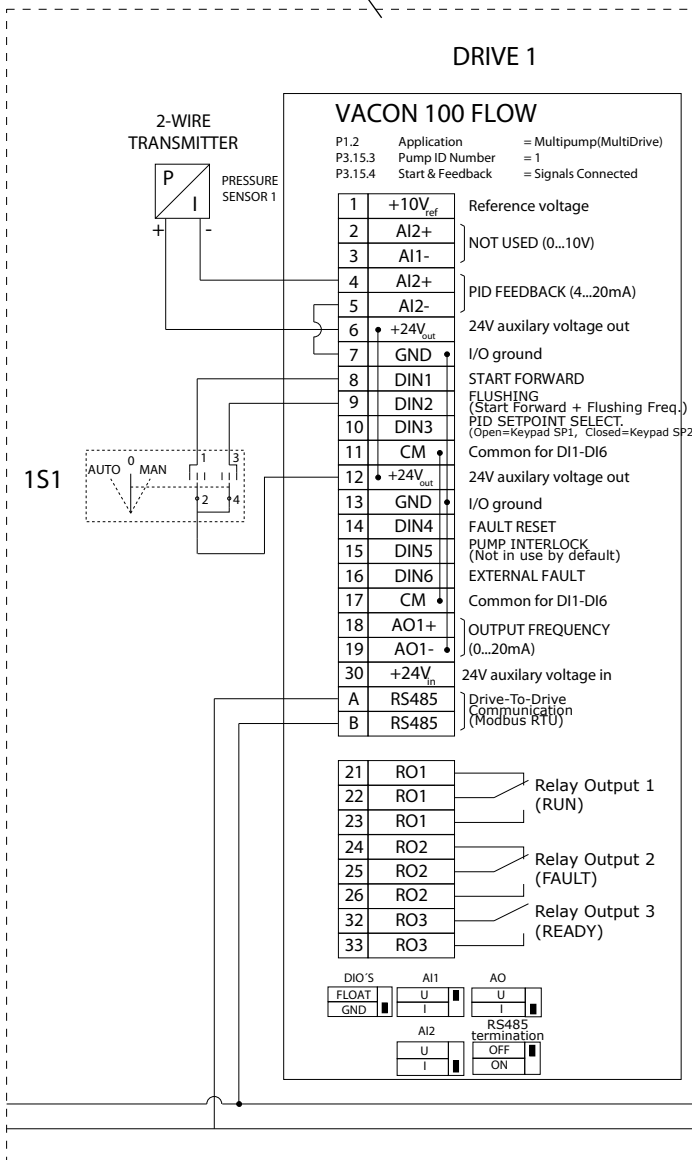
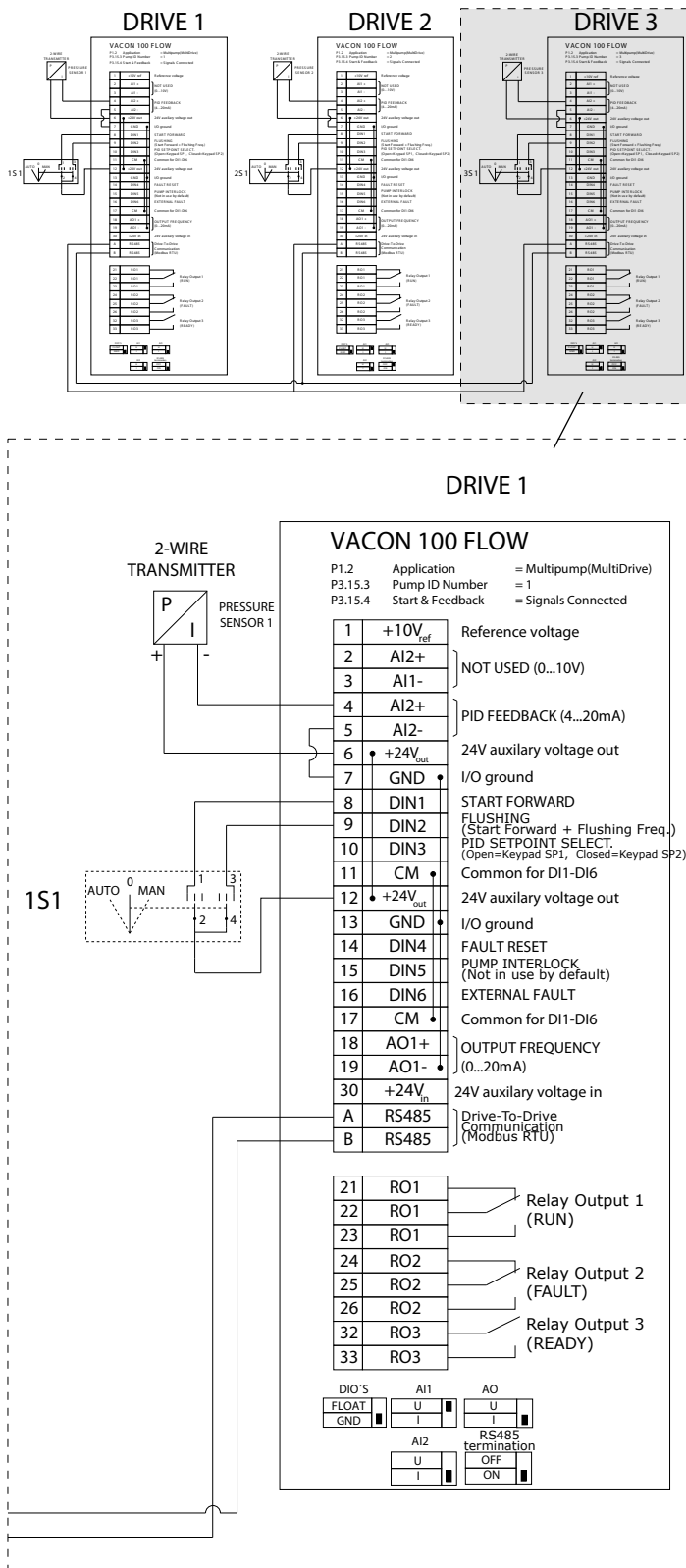

Illustration 21: Electric Wiring Diagram of the Multi-pump (Multidrive) System, Example 1B



e30b1992.10

Illustration 22: Electric Wiring Diagram of the Multi-pump (Multidrive) System, Example 1C

1 sensor is connected to all the drives. The redundancy level of the system is low because only the drives are redundant.

- If there is a drive failure, the next drive starts to operate as master.
- If there is a sensor failure, the system stops.

An individual switch that has an auto, off and man setting controls each drive. Terminal 17 connects +24 V between the drive 1 and 2. External diodes are connected between terminals 1 and 2. The digital input signals use negative logic (ON = OV).

e30bi1993.10

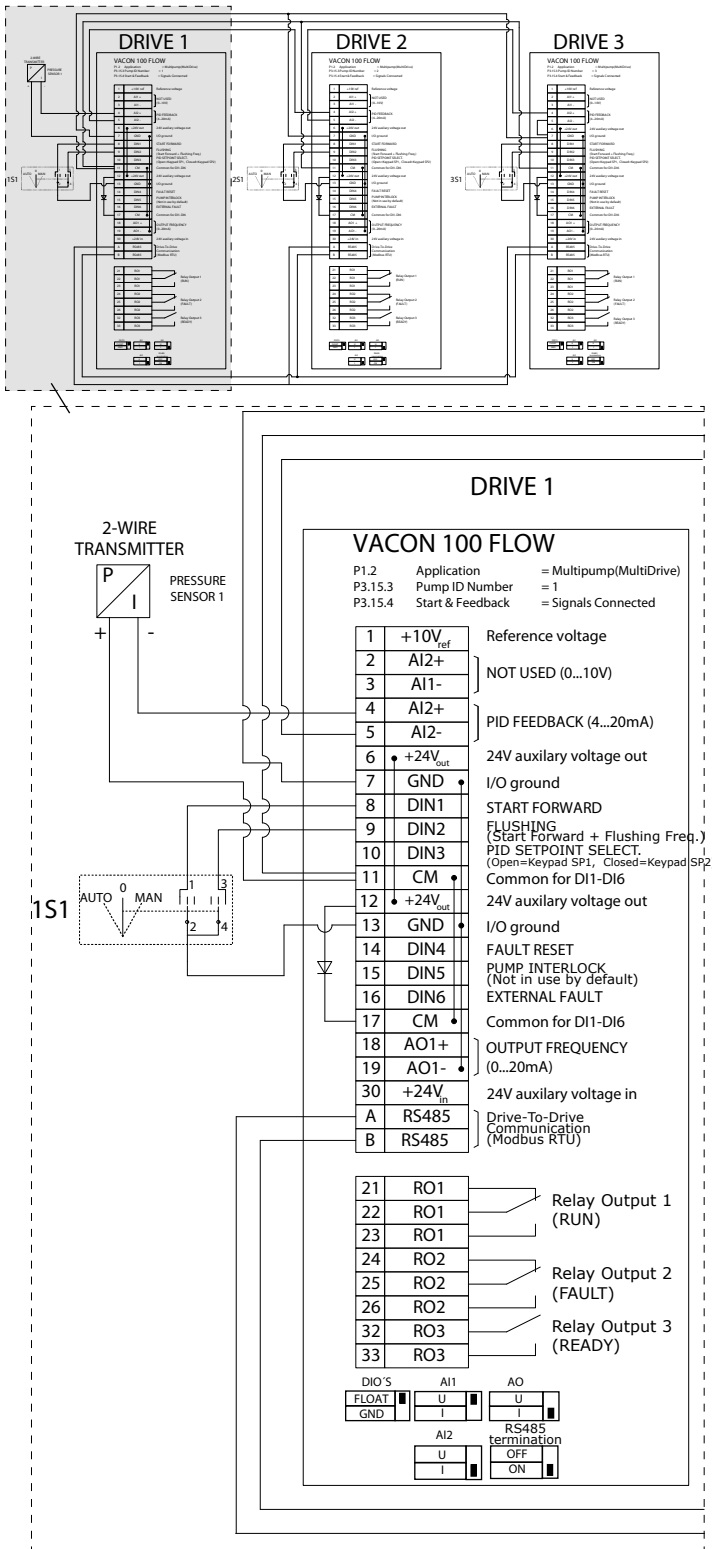
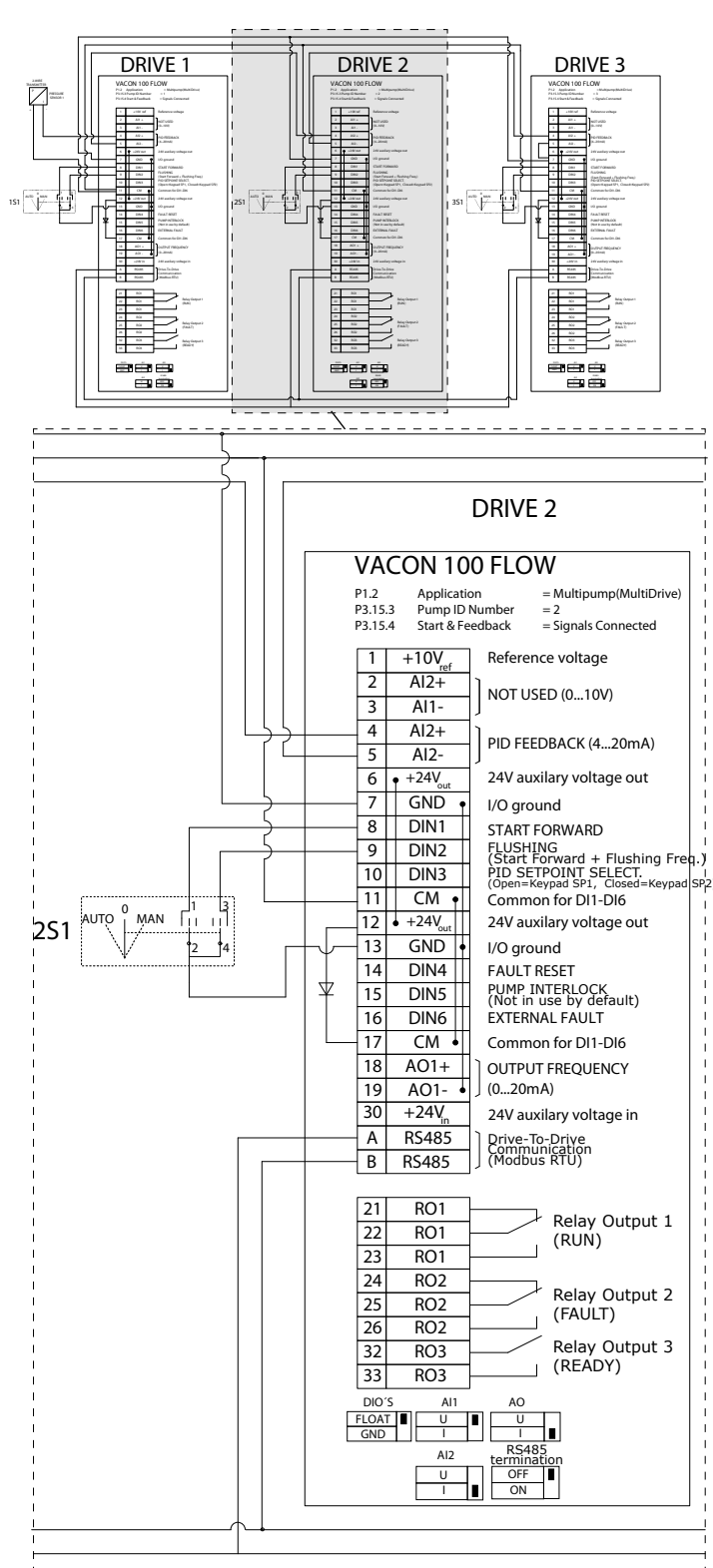
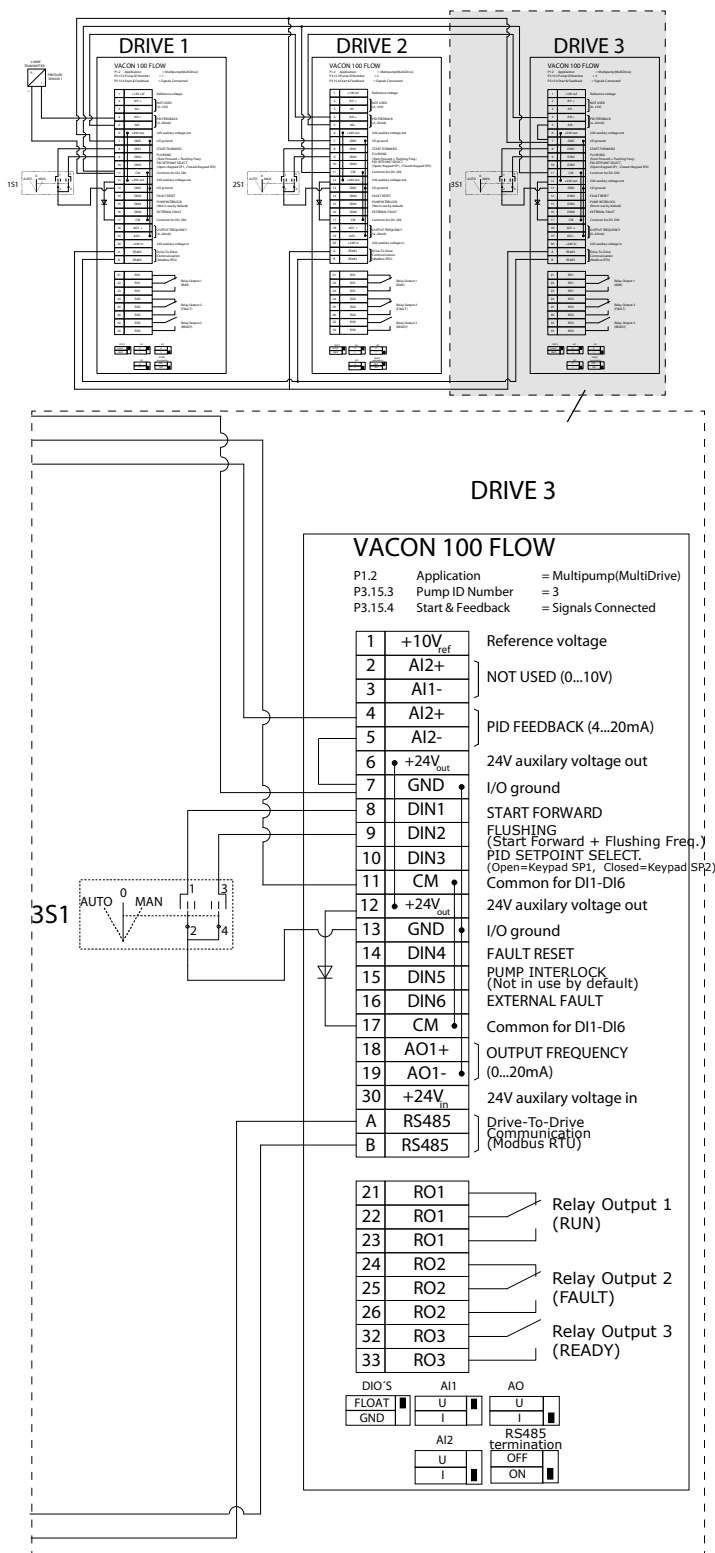

Illustration 23: Electric Wiring Diagram of the Multi-pump (Multidrive) System, Example 2A



e30bi994.10

Illustration 24: Electric Wiring Diagram of the Multi-pump (Multidrive) System, Example 2B



e30bi995.10

Illustration 25: Electric Wiring Diagram of the Multi-pump (Multidrive) System, Example 2C

2 drives have individual pressure sensors. The redundancy level of the system is medium because the drives and the pressure sensors are duplicated.

- If there is a drive failure, the second drive starts to operate as master.
- If there is a sensor failure, the second drive (that has a separate sensor) starts to operate as master.

An individual switch that has an auto, off and man setting controls each drive.

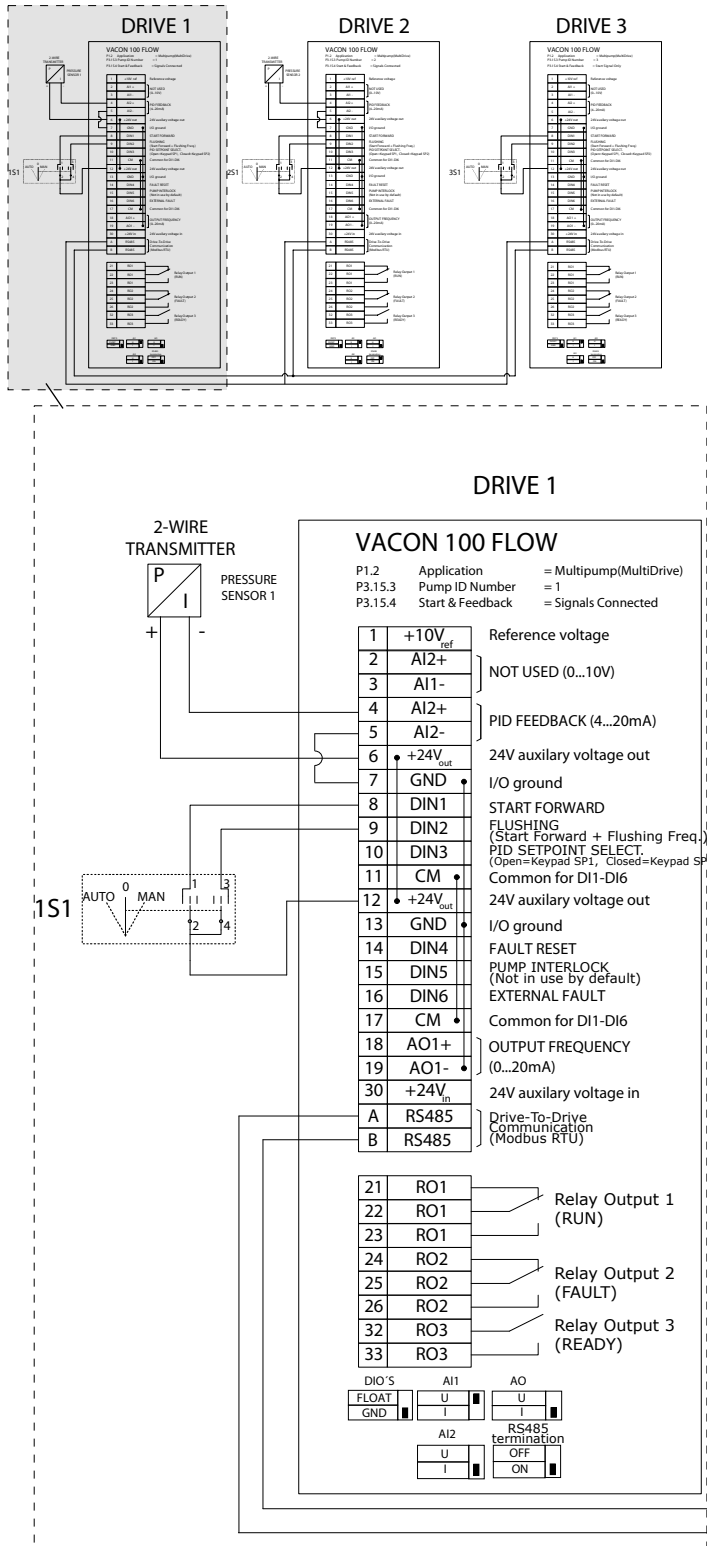

e30b996.10

Illustration 26: Electric Wiring Diagram of the Multi-pump (Multidrive) System, Example 3A

e30bi997.10

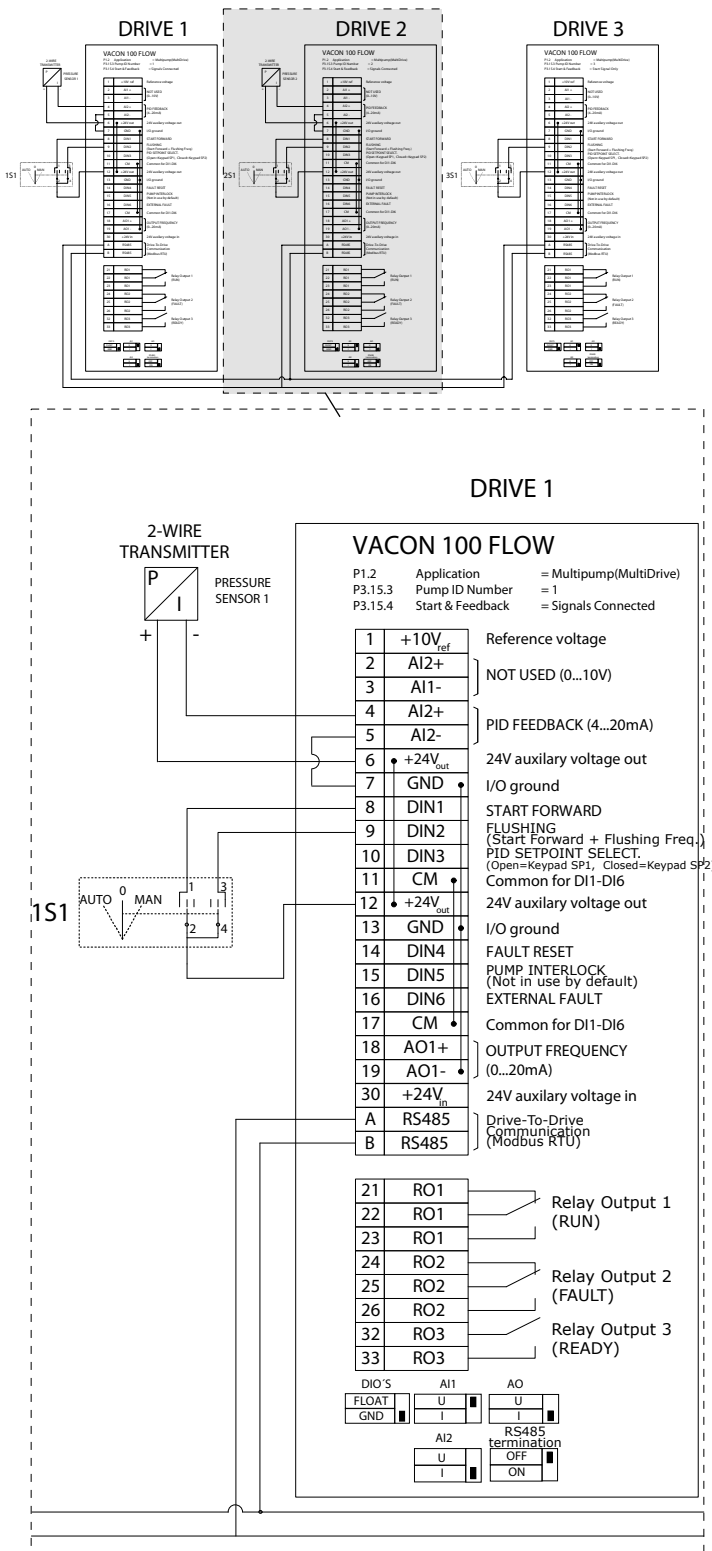
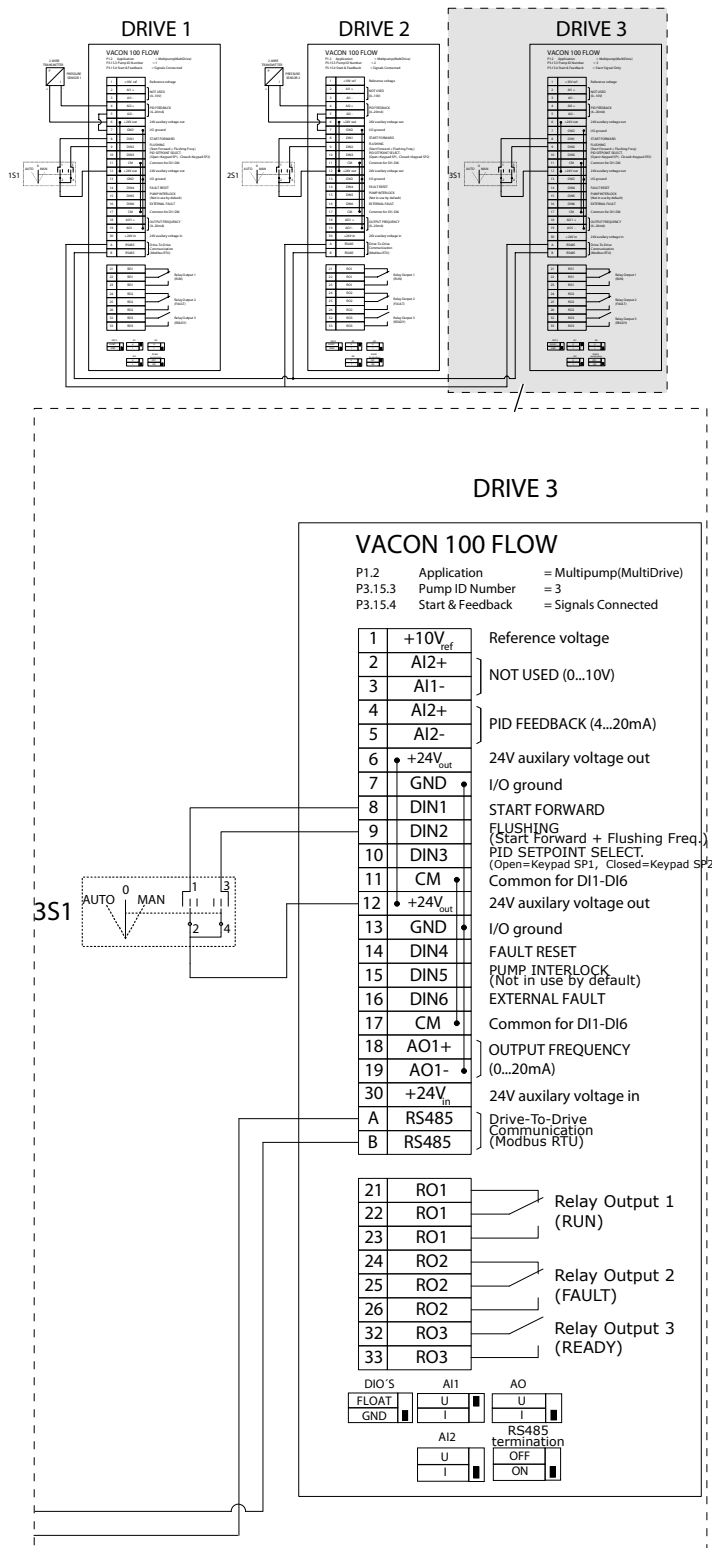

Illustration 27: Electric Wiring Diagram of the Multi-pump (Multidrive) System, Example 3B



e30b1998.10

Illustration 28: Electric Wiring Diagram of the Multi-pump (Multidrive) System, Example 3C

1 common pressure sensor is connected to 2 drives. The redundancy level of the system is low because only the drives are redundant.

- If there is a drive failure, the second drive starts to operate as master.
- If there is a sensor failure, the system stops.

An individual switch that has an auto, off and man setting controls each drive. Terminal 17 connects +24V between the drive 1 and 2. External diodes are connected between terminals 1 and 2. The digital input signals use negative logic (ON = OV).

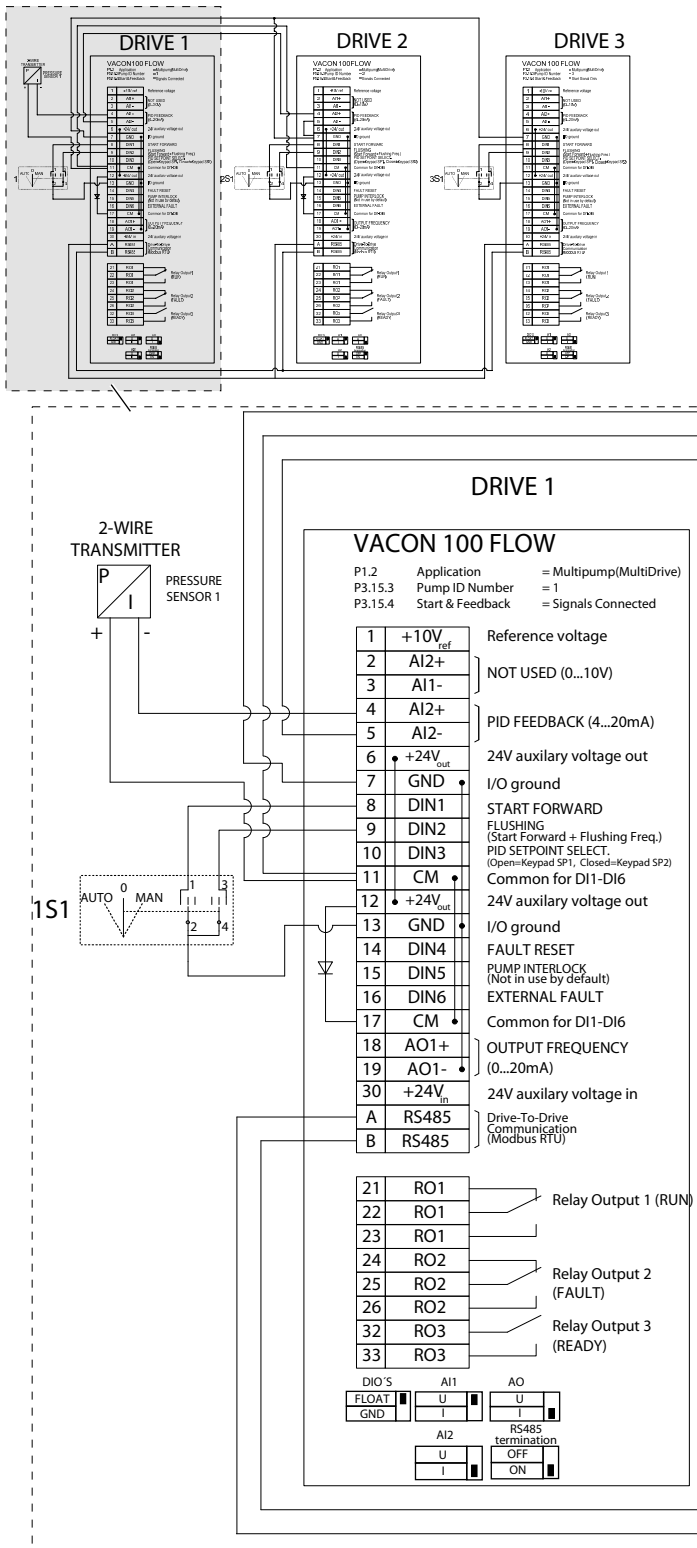

e30bi999,10

Illustration 29: Electric Wiring Diagram of the Multi-pump (Multidrive) System, Example 4A

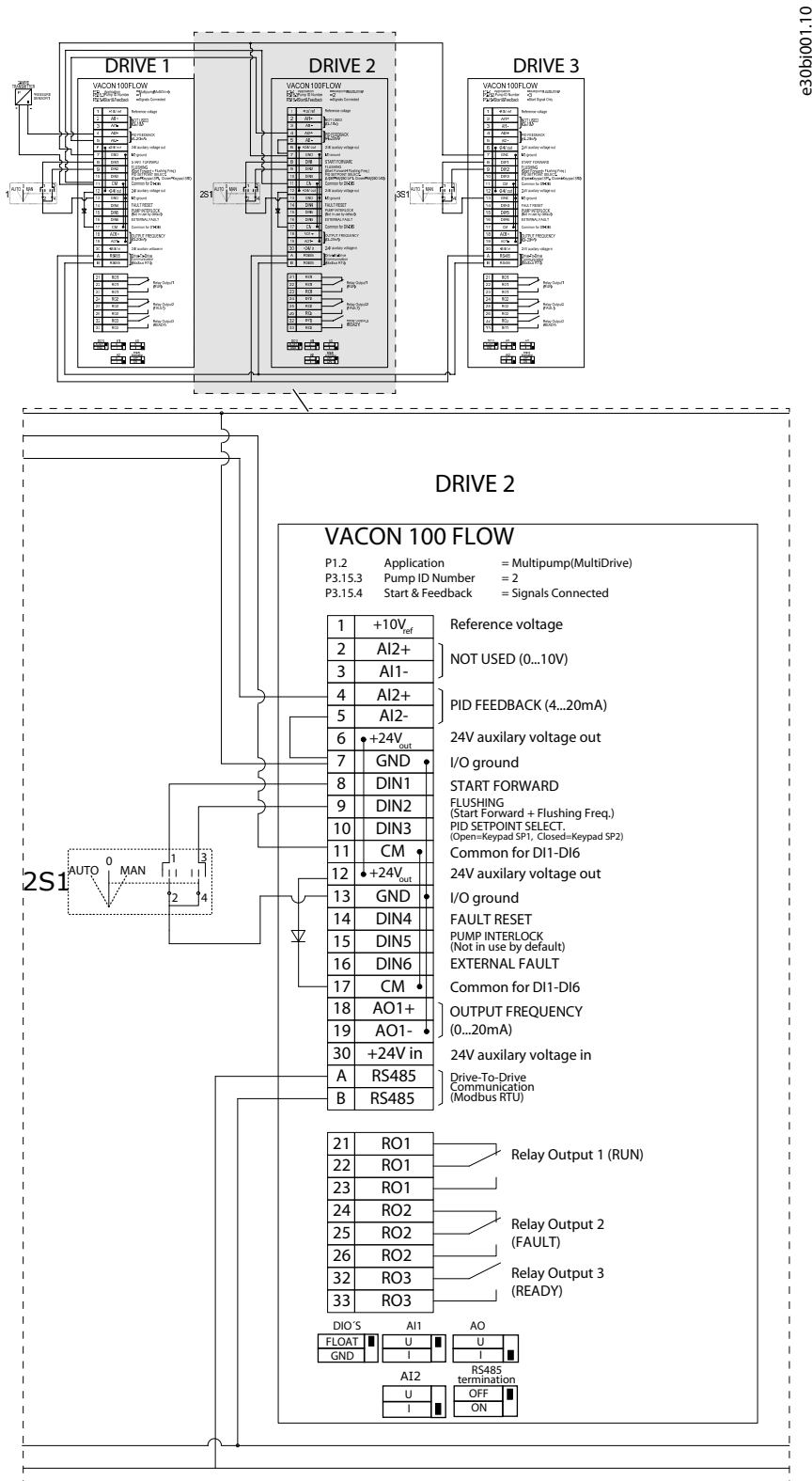

Illustration 30: Electric Wiring Diagram of the Multi-pump (Multidrive) System, Example 4B

e30bj002.10

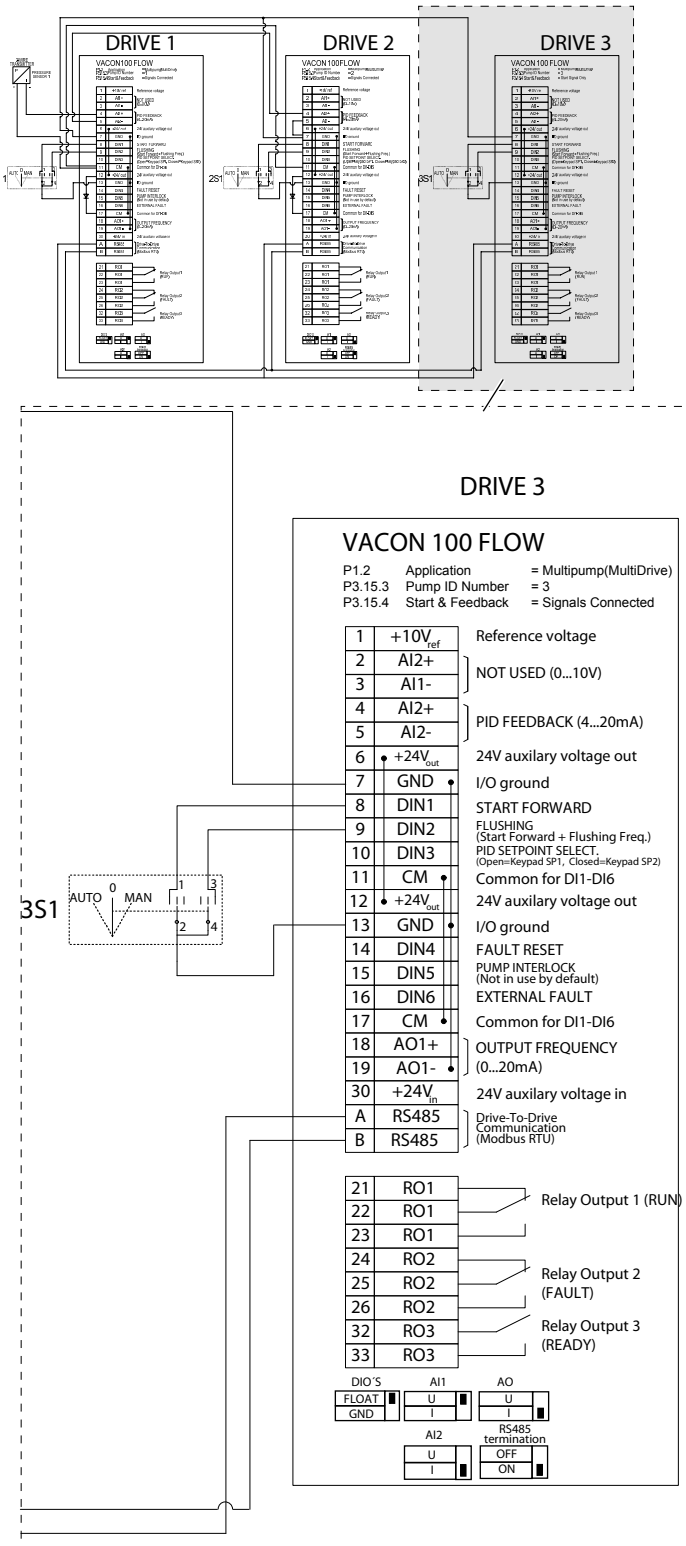
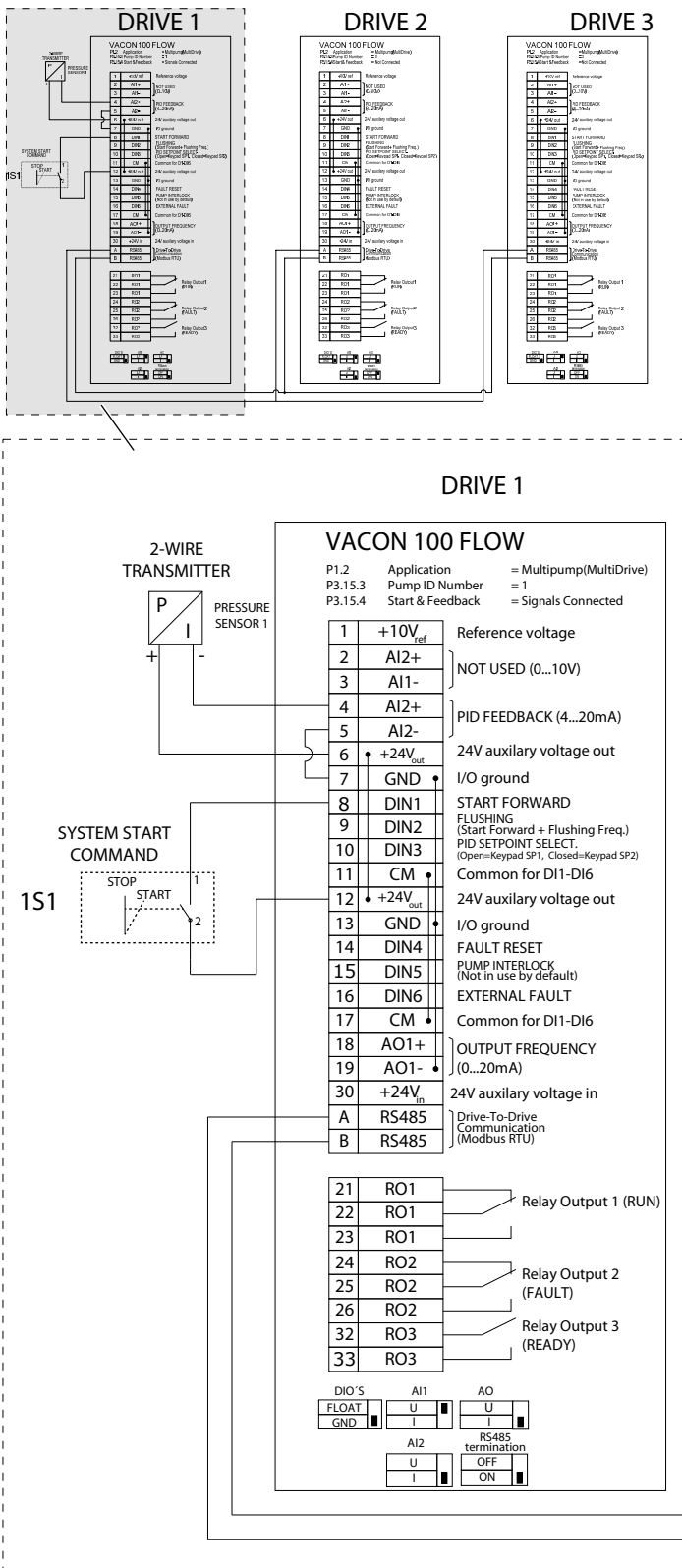

Illustration 31: Electric Wiring Diagram of the Multi-pump (Multidrive) System, Example 4C

1 pressure sensor is connected to the first drive. The system is not redundant, because the system stops if there is a drive or sensor failure.



e30bj003.10

Illustration 32: Electric Wiring Diagram of the Multi-pump (Multidrive) System, Example 5A

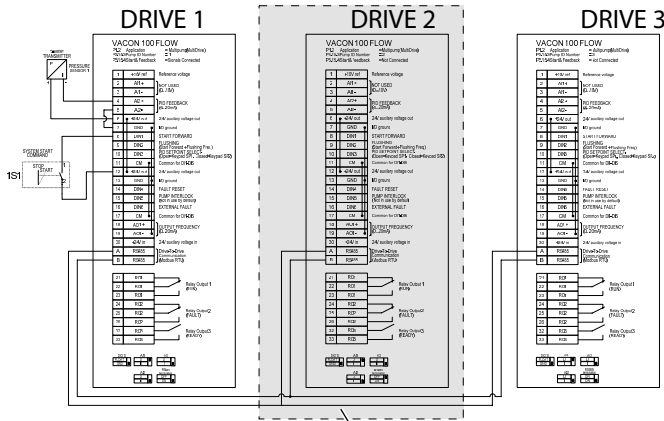

e30bj004.10

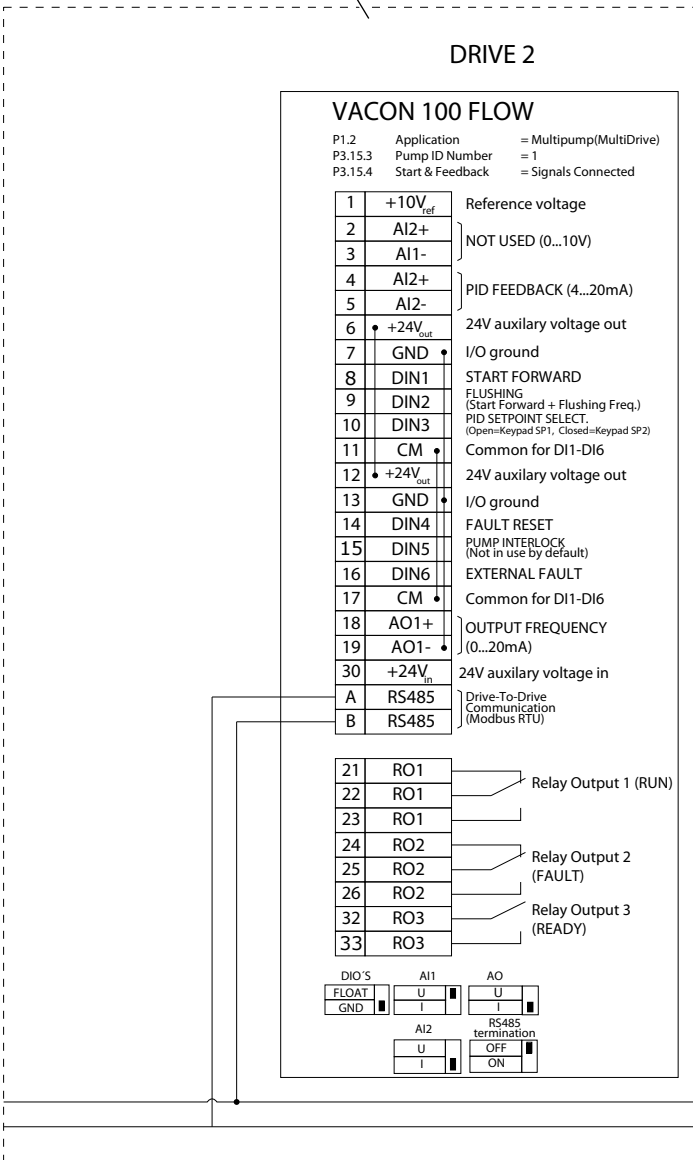
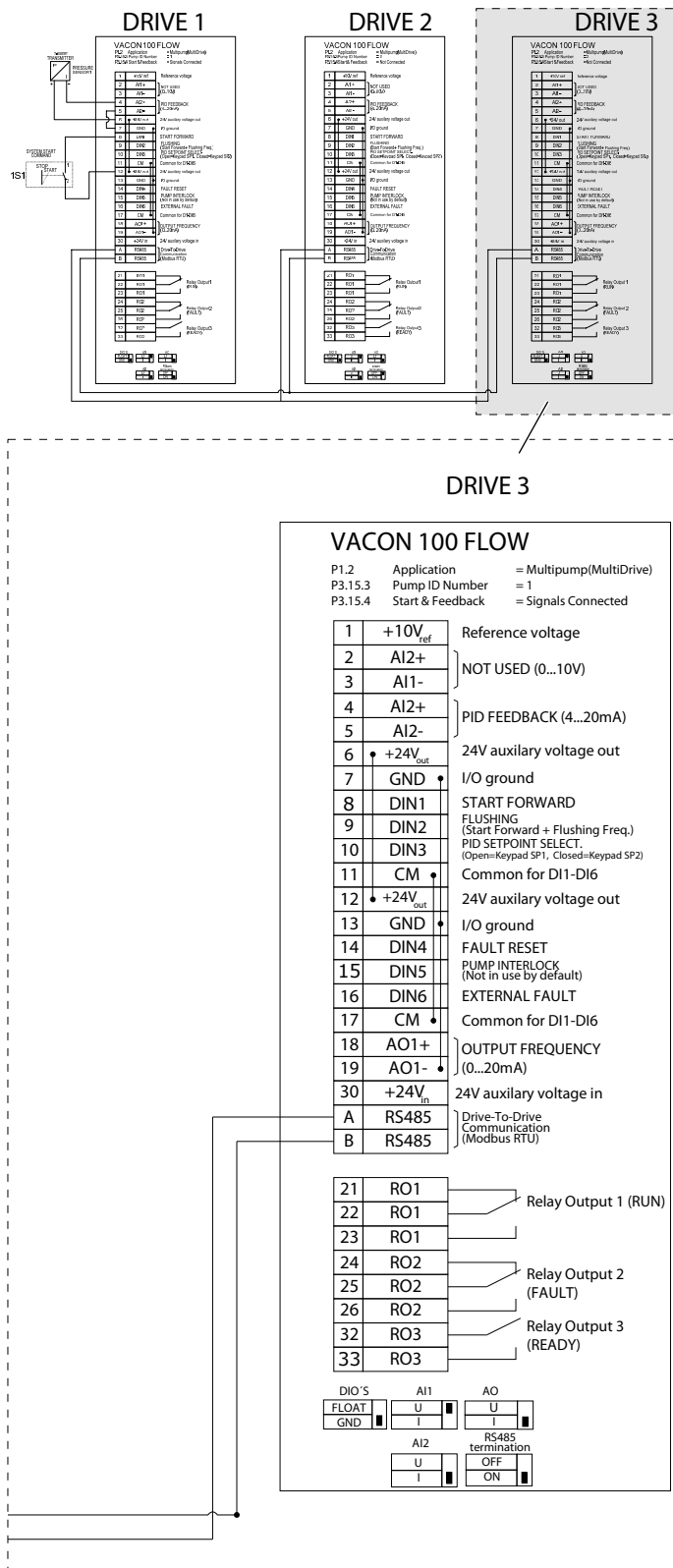

Illustration 33: Electric Wiring Diagram of the Multi-pump (Multidrive) System, Example 5B



e30bj005.10

Illustration 34: Electric Wiring Diagram of the Multi-pump (Multidrive) System, Example 5C

See information on the Startup, and Fire mode wizards in [4.2.1 Wizards in Menu 1.1](#).

Table 9: M1 Quick Setup

Index	Parameter	Min	Max	Unit	Default	ID	Description
1.2	Application	0	4		2	212	0 = Standard 1 = HVAC 2 = PID Control 3 = Multi-pump (single drive) 4 = Multi-pump (multidrive)
1.3	Minimum Frequency Reference	0.00	P1.4	Hz	0.0	101	
1.4	Maximum Frequency Reference	P1.3	320.0	Hz	50.0/60.0	102	
1.5	Acceleration Time 1	0.1	3000.0	s	5.0	103	
1.6	Deceleration Time 1	0.1	3000.0	s	5.0	104	
1.7	Motor Current Limit	I _H *0.1	I _S	A	Varies	107	
1.8	Motor Type	0	2		0	650	0 = Induction Motor 1 = Permanent Magnet Motor 2 = Reluctance Motor
1.9	Motor Nominal Voltage	Varies	Varies	V	Varies	110	Find this value U _n on the nameplate of the motor. NOTE! Find out if the motor connection is Delta or Star.
1.10	Motor Nominal Frequency	8.0	320.0	Hz	50/60	111	Find this value f _n on the nameplate of the motor.
1.11	Motor Nominal Speed	24	19200	RPM	Varies	112	Find this value n _n on the nameplate of the motor.
1.12	Motor Nominal Current	I _H * 0.1	I _S	A	Varies	113	Find this value I _n on the nameplate of the motor.
1.13	Motor Cos Phi (Power Factor)	0.30	1.00		Varies	120	Find this value on the nameplate of the motor.
1.14	Energy Optimization	0	1		0	666	0 = Disabled 1 = Enabled
1.15	Identification	0	2		0	631	0 = No action 1 = At standstill 2 = With rotation
1.16	Start Function	0	1		0	505	0 = Ramping 1 = Flying Start
1.17	Stop Function	0	1		0	506	0 = Coasting 1 = Ramping
1.18	Automatic Reset	0	1		0	731	0 = Disabled 1 = Enabled

Index	Parameter	Min	Max	Unit	Default	ID	Description
1.19	Response to External Fault	0	3		2	701	0 = No action 1 = Alarm 2 = Fault (Stop according to stop mode) 3 = Fault (Stop by coasting)
1.20	Response to AI Low Fault	0	5		0	700	0 = No action 1 = Alarm 2 = Alarm+preset fault frequency (P3.9.1.13) 3 = Alarm + previous frequency 4 = Fault (Stop according to stop mode) 5 = Fault (Stop by coasting)
1.21	Remote Control Place	0	1		0	172	0 = I/O control 1 = Fieldbus control
1.22	I/O Control Reference A Selection	1	20		6	117	1 = Preset Frequency 0 2 = Keypad reference 3 = Fieldbus 4 = AI1 5 = AI2 6 = AI1+AI2 7 = PID reference 8 = Motor potentiometer 11 = Block Out.1 12 = Block Out.2 13 = Block Out.3 14 = Block Out.4 15 = Block Out.5 16 = Block Out.6 17 = Block Out.7 18 = Block Out.8 19 = Block Out.9 20 = Block Out.10
1.23	Keypad Control Reference Selection	1	20		1	121	See P1.22.
1.24	Fieldbus Control Reference Selection	1	20		2	122	See P1.22.
1.25	AI1 Signal Range	0	1		0	379	0= 0...10 V/0...20 mA 1= 2...10 V/4...20 mA
1.26	AI2 Signal Range	0	1		1	390	0= 0...10 V/0...20 mA 1= 2...10 V/4...20 mA
1.27	RO1 Function	0	74		2	11001	See P3.5.3.2.1.
1.28	RO2 Function	0	74		3	11004	See P3.5.3.2.1.
1.29	RO3 Function	0	74		1	11007	See P3.5.3.2.1.
1.30	AO1 Function	0	31		2	10050	See P3.5.4.1.1.

Table 10: M1.34 Multi-pump (Multidrive)

Index	Parameter	Min	Max	Unit	Default	ID	Description
1.35.1	PID Gain	0.00	100.00	%	100.00	118	
1.35.2	PID Integration Time	0.00	600.00	s	1.00	119	
1.35.3	PID Derivation Time	0.00	100.00	s	0.00	132	
1.35.4	Process Unit Selection	1	44		1	1036	See P3.13.1.4
1.35.5	Process Unit Min	Varies	Varies		Varies	1033	
1.35.6	Process Unit Max	Varies	Varies		Varies	1034	
1.35.7	Feedback 1 Source Selection	0	30		2	334	See P3.13.3.3
1.35.8	Setpoint 1 Source Selection	0	32		1	332	See P3.13.2.6
1.35.9	Keypad Setpoint 1	Varies	Varies	Varies	0	167	
1.35.10	SP1 Sleep Frequency Limit	0.0	320.0	Hz	0.0	1016	
1.35.11	SP1 Sleep Delay	0	3000	s	0	1017	0 = Not used
1.35.12	SP1 Wake Up Level	Varies	Varies	Varies	Varies	1018	0 = Not used
1.35.13	Multi-pump Mode	0	2		0	1785	0= Single drive 1= Multifollower 2= Multimaster
1.35.14	Number of Pumps	1	8		1	1001	
1.35.15	Pump ID Number	1	8		1	1500	
1.35.16	Start and Feedback Signals	0	2		1	1782	0 = Not connected 1 = Only Start Signal Connected 2 = Both Signals Connected
1.35.17	Pump Interlocking	0	1		1	1032	0 = Disabled 1 = Enabled
1.35.18	Autochange	0	2		1	1027	0 = Disabled 1 = Enabled (interval) 2 = Enabled (weekdays)
1.35.19	Autochanged Pump	0	1		1	1028	0 = Auxiliary Pump 1 = All Pumps
1.35.20	Autochange Interval	0.0	3000.0	h	48.0	1029	
1.35.21	Autochange Days	0	127			1786	
1.35.22	Autochange Time of Day			Time		1787	
1.35.23	Autochange: Frequency Limit	0.00	P3.3.1.2	Hz	25:00	1031	
1.35.24	Autochange: Pump Limit	1	6			1030	

Index	Parameter	Min	Max	Unit	Default	ID	Description
1.35.25	Bandwidth	0	100	%	10	1097	
1.35.26	Bandwidth Delay	0	3600	s	10	1098	
1.35.27	Constant Production Speed	0	100	%	100	1513	
1.35.28	Pump 1 Interlock				DigIN Slot0.1	426	OPEN = Not active CLOSED = Active
1.35.29	Flushing Reference	Maximum reference	Maximum reference	Hz	50.00	1239	

4 Wizards

4.1 Application Wizards

4.1.1 Standard Application Wizard

The application wizard helps to set the basic parameters that are related to the application.

To start the Standard application wizard, set the value Standard to parameter P1.2 Application (ID 212) in the keypad.

If the application wizard is started from the Start-up wizard, the wizard goes directly to step 11.

See the range of values of the parameters in [6.1 Group 3.1: Motor Settings](#), [6.3 Group 3.3: References](#), [6.4 Group 3.4: Ramps and Brakes Setup](#).

Procedure

1. Set a value for P3.1.2.2 Motor Type (so that it agrees with the nameplate of the motor).

➡ If Motor Type is set to Induction Motor, also step 6 is shown. If the selection is PM Motor, the value of parameter P3.1.1.5 Motor Cos Phi is set to 1.00, and the wizard skips step 6.

2. Set a value for P3.1.1.1 Motor Nominal Voltage (so that it agrees with the nameplate of the motor).
3. Set a value for P3.1.1.2 Motor Nominal Frequency (so that it agrees with the nameplate of the motor).
4. Set a value for P3.1.1.3 Motor Nominal Speed (so that it agrees with the nameplate of the motor).
5. Set a value for P3.1.1.4 Motor Nominal Current (so that it agrees with the nameplate of the motor).
6. Set a value for P3.1.1.5 Motor Cos Phi (so that it agrees with the nameplate of the motor).
7. Set a value for P3.3.1.1 Minimum Frequency Reference.
8. Set a value for P3.3.1.2 Maximum Frequency Reference.
9. Set a value for P3.4.1.2 Acceleration Time 1.
10. Set a value for P3.4.1.3 Deceleration Time 1.
11. Select the a control place (where to give the start and stop commands, and the frequency reference of the drive).

➡ The Standard application wizard is completed.

4.1.2 HVAC Application Wizard

The application wizard helps to set the basic parameters that are related to the application.

To start the HVAC application wizard, set the value Standard to parameter P1.2 Application (ID 212) in the keypad.

See the range of values of the parameters in [6.2 Group 3.2: Start/Stop Setup](#), [6.1 Group 3.1: Motor Settings](#), [6.3 Group 3.3: References](#), [6.4 Group 3.4: Ramps and Brakes Setup](#).

Procedure

1. Select the type or process (or application) to control.
 - Compressor
 - Fan
 - Pump
 - Other

Some parameters have preset values specified by the selection. See the parameters and their values in the following table.

Table 11: Preset Values of Parameters

Index	Parameter	Process type		
		Pump	Fan	Compressor
P3.1.4.1	U/f Ratio	Linear	Squared	Linear
P3.2.4	Start Function	Ramping	Flying start	Ramping

Index	Parameter	Process type		
		Pump	Fan	Compressor
P3.2.5	Stop Function	Ramping	Coasting	Ramping
P3.4.1.2	Acceleration Time	5.0 s	30.0 s	3.0 s
P3.4.1.3	Deceleration Time	5.0 s	30.0 s	3.0 s

➡ If process is set to Compressor, also step 2 is shown. If the selection is anything else, the wizard skips step 2. If process is set to Other, also steps 11 and 12 are shown.

2. Set a value for P3.2.11 Restart Delay.
3. Set a value for P3.1.2.2 Motor Type (so that it agrees with the nameplate of the motor).

➡ If Motor Type is set to Induction Motor, also step 8 is shown. If the selection is PM Motor, the value of parameter P3.1.1.5 Motor Cos Phi is set to 1.00, and the wizard skips step 8.

4. Set a value for P3.1.1.1 Motor Nominal Voltage (so that it agrees with the nameplate of the motor).
5. Set a value for P3.1.1.2 Motor Nominal Frequency (so that it agrees with the nameplate of the motor).
6. Set a value for P3.1.1.3 Motor Nominal Speed (so that it agrees with the nameplate of the motor).
7. Set a value for P3.1.1.4 Motor Nominal Current (so that it agrees with the nameplate of the motor).
8. Set a value for P3.1.1.5 Motor Cos Phi (so that it agrees with the nameplate of the motor).
9. Set a value for P3.3.1.1 Minimum Frequency Reference.
10. Set a value for P3.3.1.2 Maximum Frequency Reference.
11. Set a value for P3.4.1.2 Acceleration Time 1.
12. Set a value for P3.4.1.3 Deceleration Time 1.

➡ The wizard goes to steps specified by the application.

13. Select the control place (where to give the start and stop commands, and the frequency reference of the drive).

➡ The HVAC application wizard is completed.

4.1.3 PID Control Application Wizard

The application wizard helps to set the basic parameters that are related to the application.

To start the PID Control application wizard, set the value PID Control to parameter P1.2 Application (ID 212) in the keypad.

If the application wizard is started from the Start-up wizard, the wizard goes directly to step 11.

See the range of values of the parameters in [6.1 Group 3.1: Motor Settings](#), [6.3 Group 3.3: References](#), [6.4 Group 3.4: Ramps and Brakes Setup](#), [6.13 Group 3.13: PID Controller](#).

Procedure

1. Set a value for P3.1.2.2 Motor Type (so that it agrees with the nameplate of the motor).

➡ If Motor Type is set to Induction Motor, also step 6 is shown. If the selection is PM Motor, the value of parameter P3.1.1.5 Motor Cos Phi is set to 1.00, and the wizard skips step 6.

2. Set a value for P3.1.1.1 Motor Nominal Voltage (so that it agrees with the nameplate of the motor).
3. Set a value for P3.1.1.2 Motor Nominal Frequency (so that it agrees with the nameplate of the motor).
4. Set a value for P3.1.1.3 Motor Nominal Speed (so that it agrees with the nameplate of the motor).
5. Set a value for P3.1.1.4 Motor Nominal Current (so that it agrees with the nameplate of the motor).
6. Set a value for P3.1.1.5 Motor Cos Phi (so that it agrees with the nameplate of the motor).
7. Set a value for P3.3.1.1 Minimum Frequency Reference.
8. Set a value for P3.3.1.2 Maximum Frequency Reference.
9. Set a value for P3.4.1.2 Acceleration Time 1.
10. Set a value for P3.4.1.3 Deceleration Time 1.
11. Select a control place (where to give the start and stop commands, and the frequency reference of the drive).

12. Set a value for P3.13.1.4 Process Unit Selection.

➔ If the selection is other than %, the next steps are shown. If the selection is %, the wizard goes directly to step 16.

13. Set a value for P3.13.1.5 Process Unit Min.

The range depends on the selection in step 12.

14. Set a value for P3.13.1.6 Process Unit Max.

The range depends on the selection in step 12.

15. Set a value for P3.13.1.7 Process Unit Decimals.

16. Set a value for P3.13.3.3 Feedback 1 Source Selection.

See the table Feedback settings in chapter [6.13 Group 3.13: PID Controller](#).

➔ If analog input signal is selected, step 18 is shown. With other selections, the wizard goes to step 19.

17. Set the signal range of the analog input.

18. Set a value for P3.13.1.8 Error Inversion.

19. Set a value for P3.13.2.6 Setpoint Source Selection.

See table Setpoints in chapter [6.13 Group 3.13: PID Controller](#).

➔ If analog input signal is selected, step 21 is shown. With other selections, the wizard goes to step 23. If Keypad Setpoint 1 or Keypad Setpoint 2 are set for the value, the wizard goes directly to step 22.

20. Set the signal range of the analog input.

21. Set a value for P3.13.2.1 (Keypad Setpoint 1) and P3.13.2.2 (Keypad Setpoint 2).

Depends on the range set in step 20.

22. Using the sleep function.

➔ If value Yes is set for step 22, the next 3 steps are shown. If the value No is selected, the wizard is completed.

23. Set a value for P3.13.5.1 SP1 Sleep Frequency Limit.

24. Set a value for P3.13.5.2 SP1 Sleep Delay.

25. Set a value for P3.13.5.3 SP1 Wake-up Level.

The range depends on the set process unit.

➔ The PID Control application wizard is completed.

4.1.4 Multi-pump (Single Drive) Application Wizard

The application wizard helps to set the basic parameters that are related to the application.

To start the Multi-pump (single drive application wizard, set the value PID Control to parameter P1.2 Application (ID 212) in the keypad.

If the application wizard is started from the Start-up wizard, the wizard goes directly to step 11.

See the range of values of the parameters in [6.1 Group 3.1: Motor Settings](#), [6.3 Group 3.3: References](#), [6.4 Group 3.4: Ramps and Brakes Setup](#), [6.13 Group 3.13: PID Controller](#).

Procedure

1. Set a value for P3.1.2.2 Motor Type (so that it agrees with the nameplate of the motor).

➔ If Motor Type is set to Induction Motor, also step 6 is shown. If the selection is PM Motor, the value of parameter P3.1.1.5 Motor Cos Phi is set to 1.00, and the wizard skips step 6.

2. Set a value for P3.1.1.1 Motor Nominal Voltage (so that it agrees with the nameplate of the motor).
3. Set a value for P3.1.1.2 Motor Nominal Frequency (so that it agrees with the nameplate of the motor).
4. Set a value for P3.1.1.3 Motor Nominal Speed (so that it agrees with the nameplate of the motor).
5. Set a value for P3.1.1.4 Motor Nominal Current (so that it agrees with the nameplate of the motor).

6. Set a value for P3.1.1.5 Motor Cos Phi (so that it agrees with the nameplate of the motor).
7. Set a value for P3.3.1.1 Minimum Frequency Reference.
8. Set a value for P3.3.1.2 Maximum Frequency Reference.
9. Set a value for P3.4.1.2 Acceleration Time 1.
10. Set a value for P3.4.1.3 Deceleration Time 1.
11. Select a control place (where to give the start and stop commands, and the frequency reference of the drive).
12. Set a value for P3.13.1.4 Process Unit Selection.

➡ If the selection is other than %, the next steps are shown. If the selection is %, the wizard goes directly to step 16.

13. Set a value for P3.13.1.5 Process Unit Min.
14. Set a value for P3.13.1.6 Process Unit Max.
15. Set a value for P3.13.1.7 Process Unit Decimals.
16. Set a value for P3.13.3.3 Feedback 1 Source Selection.

See the table Feedback settings in chapter [6.13 Group 3.13: PID Controller](#).

➡ If analog input signal is selected, step 17 is shown. With other selections, the wizard goes to step 18.

17. Set the signal range of the analog input.

See table Analog inputs in chapter [6.5 Group 3.5: I/O Configuration](#).

18. Set a value for P3.13.1.8 Error Inversion.
19. Set a value for P3.13.2.6 Setpoint Source Selection.

See table Setpoints in chapter [6.13 Group 3.13: PID Controller](#).

➡ If analog input signal is selected, step 20 is shown. With other selections, the wizard goes to step 21. If Keypad Setpoint 1 or Keypad Setpoint 2 is selected for the value, step 22 is shown.

20. Set the signal range of the analog input.

See table Analog inputs in chapter [6.5 Group 3.5: I/O Configuration](#).

21. Set a value for P3.13.2.1 (Keypad setpoint 1) and P3.13.2.2 (Keypad setpoint 2).
22. Using the sleep function.

➡ If the value "Yes" is given step 22, the next 3 steps are shown.

23. Set a value for P3.13.5.1 SP1 Sleep Frequency Limit.
24. Set a value for P3.13.5.2 SP1 Sleep Delay.
25. Set a value for P3.13.5.3 SP1 Wake-up Level.
26. Set a value for P3.15.2 Number of pumps.
27. Set a value for P3.15.5 Pump Interlocking.
28. Set a value for P3.15.6 Autochange.

➡ If the value Enabled (Interval or Weekdays) is set to parameter Autochange, the next 6 steps are shown. If the Autochange function is not used, the wizard goes directly to step 21.

29. Set a value for P3.15.7 Autochanged pumps.

➡ If the value Enabled (Interval) is set to parameter Autochange in step 28, the next step is shown.

30. Set a value for P3.15.8 Autochange Interval.

➡ If the value Enabled (Weekdays) is set to parameter Autochange in step 28, the next 2 steps are shown.

31. Set a value for P3.15.9 Autochange Days.
32. Set a value for P3.15.10 Autochange Time of Day.
33. Set a value for P3.15.11 Autochange Frequency Limit.
34. Set a value for P3.15.12 Autochange Pump Limit.

35. Set a value for P3.15.13 Bandwidth.
36. Set a value for P3.15.14 Bandwidth Delay.

➔ The Multi-pump (single drive) application wizard is completed.

4.1.5 Multi-pump (Multidrive) Application Wizard

The application wizard helps to set the basic parameters that are related to the application.

To start the Multi-pump (single drive) application wizard, set the value PID Control to parameter P1.2 Application (ID 212) in the keypad.

If the application wizard is started from the Start-up wizard, the wizard goes directly to step 11.

See the range of values of the parameters in [6.1 Group 3.1: Motor Settings](#), [6.3 Group 3.3: References](#), [6.4 Group 3.4: Ramps and Brakes Setup](#), [6.13 Group 3.13: PID Controller](#).

Procedure

1. Set a value for P3.1.2.2 Motor Type (so that it agrees with the nameplate of the motor).

➔ If Motor Type is set to Induction Motor, also step 6 is shown. If the selection is PM Motor, the value of parameter P3.1.1.5 Motor Cos Phi is set to 1.00, and the wizard skips step 6.

2. Set a value for P3.1.1.1 Motor Nominal Voltage (so that it agrees with the nameplate of the motor).
3. Set a value for P3.1.1.2 Motor Nominal Frequency (so that it agrees with the nameplate of the motor).
4. Set a value for P3.1.1.3 Motor Nominal Speed (so that it agrees with the nameplate of the motor).
5. Set a value for P3.1.1.4 Motor Nominal Current (so that it agrees with the nameplate of the motor).
6. Set a value for P3.1.1.5 Motor Cos Phi (so that it agrees with the nameplate of the motor).
7. Set a value for P3.3.1.1 Minimum Frequency Reference.
8. Set a value for P3.3.1.2 Maximum Frequency Reference.
9. Set a value for P3.4.1.2 Acceleration Time 1.
10. Set a value for P3.4.1.3 Deceleration Time 1.
11. Select a control place (where to give the start and stop commands, and the frequency reference of the drive).
12. Set a value for P3.13.1.4 Process Unit Selection.

➔ If the selection is other than %, the next steps are shown. If the selection is %, the wizard goes directly to step 16.

13. Set a value for P3.13.1.5 Process Unit Min.
14. Set a value for P3.13.1.6 Process Unit Max.
15. Set a value for P3.13.1.7 Process Unit Decimals.
16. Set a value for P3.13.3.3 Feedback 1 Source Selection.

See the table Feedback settings in chapter [6.13 Group 3.13: PID Controller](#).

➔ If analog input signal is selected, step 17 is shown. With other selections, the wizard goes to step 18.

17. Set the signal range of the analog input.

See table Analog inputs in chapter [6.5 Group 3.5: I/O Configuration](#).

18. Set a value for P3.13.1.8 Error Inversion.
19. Set a value for P3.13.2.6 Setpoint Source Selection.

See table Setpoints in chapter [6.13 Group 3.13: PID Controller](#).

➔ If analog input signal is selected, step 20 is shown. With other selections, the wizard goes to step 21. If Keypad Setpoint 1 or Keypad Setpoint 2 is selected for the value, step 22 is shown.

20. Set the signal range of the analog input.

See table Analog inputs in chapter [6.5 Group 3.5: I/O Configuration](#).

21. Set a value for P3.13.2.1 (Keypad setpoint 1) and P3.13.2.2 (Keypad setpoint 2).

22. Using the sleep function.

➡ If the value "Yes" is given step 22, the next 3 steps are shown.

- 23. Set a value for P3.13.5.1 SP1 Sleep Frequency Limit.
- 24. Set a value for P3.13.5.2 SP1 Sleep Delay.
- 25. Set a value for P3.13.5.3 SP1 Wake-up Level.
- 26. Set a value for P3.15.1 Multi-pump Mode.
- 27. Set a value for P3.15.3 Pump ID Number.
- 28. Set a value for P3.15.4 Start and Feedback.
- 29. Set a value for P3.15.2 Number of pumps.
- 30. Set a value for P3.15.5 Pump Interlocking.
- 31. Set a value for P3.15.6 Autochange.

➡ If the value Enabled (Interval) is set to parameter Autochange, step 33 shows. If the value Enabled (Weekdays) is set to parameter Autochange, step 34 shows. If the Autochange function is not used, the wizard goes directly to step 36.

32. Set a value for P3.15.7 Autochanged pumps.

➡ If the value Enabled (Interval) is set to parameter Autochange in step 31, the next step is shown.

33. Set a value for P3.15.8 Autochange Interval.

➡ If the value Enabled (Weekdays) is set to parameter Autochange in step 31, the next 2 steps are shown.

- 34. Set a value for P3.15.9 Autochange Days.
- 35. Set a value for P3.15.10 Autochange Time of Day.
- 36. Set a value for P3.15.13 Bandwidth.
- 37. Set a value for P3.15.14 Bandwidth Delay.

➡ The Multi-pump (single drive) application wizard is completed.

4.2 Function Wizards

4.2.1 Wizards in Menu 1.1

Table 12: M1.1 Wizards

Index	Parameter	Min	Max	Unit	Default	ID	Description
1.1.1	Start-up wizard	0	1		0	1171	0 = Do not activate 1 = Activate The selection Activate starts the Start-up wizard (see 1.6.1 Start-Up Wizard).
1.1.2	Fire mode Wizard	0	1		0	1672	The selection Activate starts the Fire mode wizard (see 4.2.2 Fire Mode Wizard).

4.2.2 Fire Mode Wizard

To start the Fire Mode Wizard, make the selection Activate for parameter B1.1.4 in the Quick setup menu. See [11.19.1 The Fire Mode Function](#) for information on the password and warranty.

See the range of values of the parameters in [6.17 Group 3.17: Fire Mode](#).

NOTICE

Before continuing, read about the password and warranty.

Procedure

1. Set a value for parameter P3.17.2 Fire Mode Frequency Source.

 If other value than Fire mode frequency is selected, the wizard goes directly to step 3.

2. Set a value for parameter P3.17.3 Fire Mode Frequency.
3. Activate the signal when the contact opens or when it closes.
4. Set a value for parameters P3.17.4 Fire Mode Activation on OPEN/P3.17.5 Fire Mode Activation on CLOSE.

See also chapter [11.7.1.1 General Information on the Programming](#).

5. Set a value for parameter P3.17.6 Fire Mode Reverse.
6. Set a value for P3.17.1 Fire Mode Password.

5 Monitor Menu

5.1 Uses of the Monitor Menu

Monitor Menu allows monitoring the actual values of the parameters and signals. It also allows monitoring the statuses and measurements. Some of the values to be monitored can be customized.

5.2 Multimonitor Monitoring

5.2.1 Changing the Items to Monitor

On the *Multimonitor* page, 4–9 items to monitor can be collected. Select the number of items with the parameter 3.11.4 Multimonitor View. See more in [6.11 Group 3.11: Application Settings](#).

Procedure

1. Go into the *Monitor* menu with the [OK] button.
2. Go into *Multimonitor*.
3. To replace an old item, activate it. Use the arrow buttons.

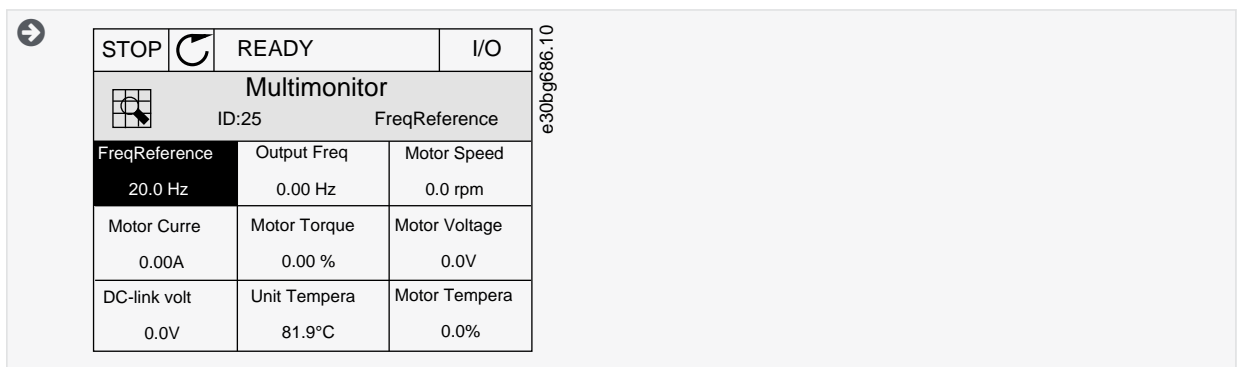

4. To select a new item in the list, push [OK].

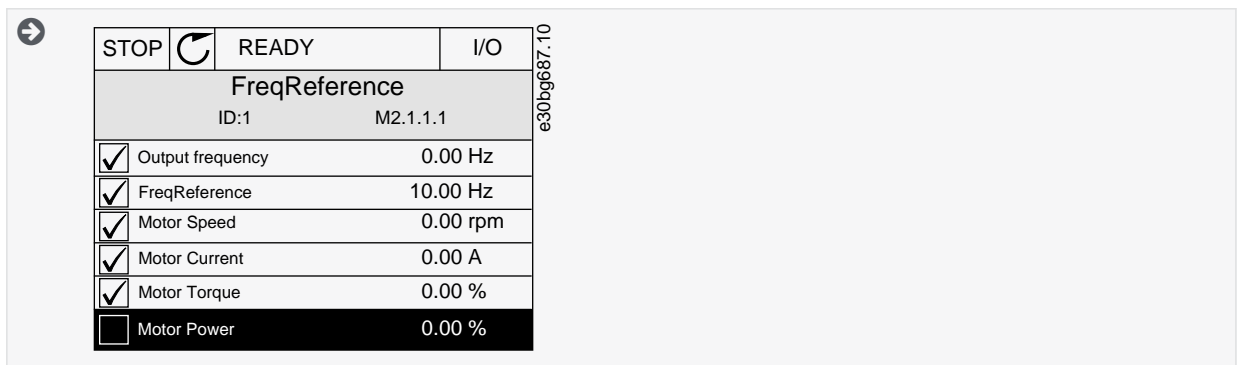

5.3 Trend Curve Monitoring

5.3.1 Uses of the Trend Curve

The Trend curve is a graphical presentation of 2 monitor values.

When a value is selected, the drive starts to record the values. The *Trend curve* submenu allows examining the trend curve, and making the signal selections. Also the minimum and maximum settings and the sampling interval, and use autoscaling can be given there.

5.3.2 Changing the Values in Trend Curve Monitoring

Procedure

1. In the *Monitor* menu, find the *Trend curve* submenu and push [OK].
2. Go into the submenu *View trend curve* with the [OK] button.

- To select the current value that to change, use the arrow buttons up and down. Push [OK].

Only 2 values as trend curves can be monitored at the same time. The current selections, *FreqReference*, and *Motor speed*, are at the bottom of the display.

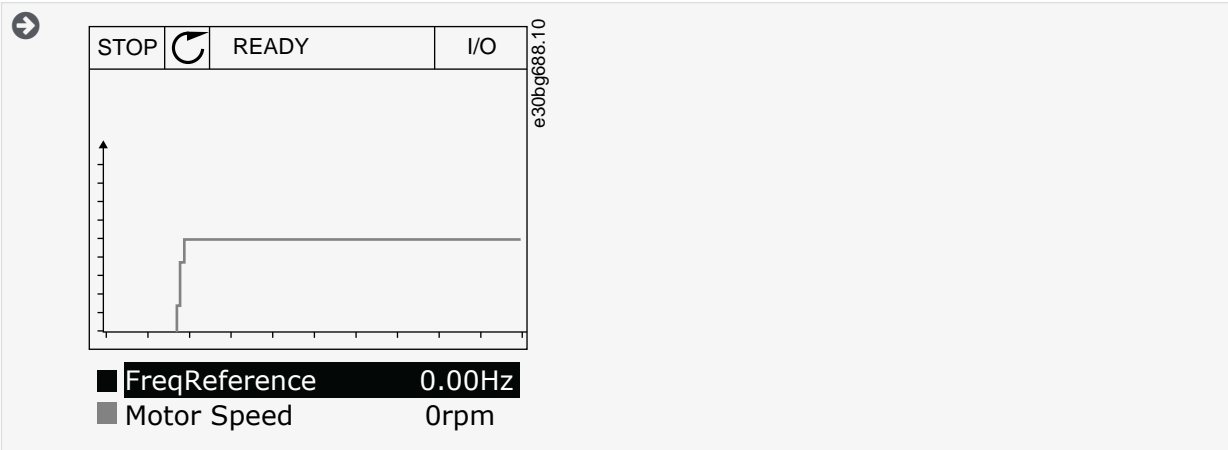

- Go through the list of the monitoring values with the arrow buttons.

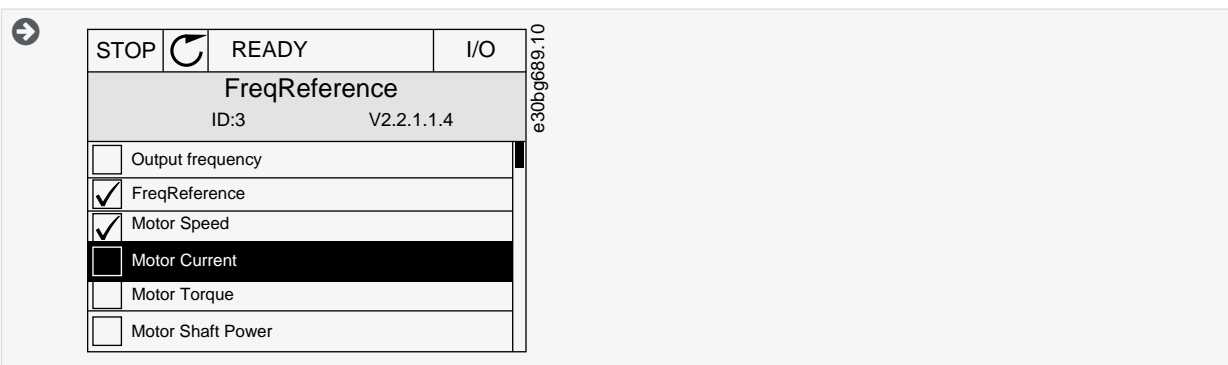

- Make a selection and push [OK].

5.3.3 Stopping the Progression of the Curve

The *Trend curve* function allows stopping the curve and reading the current values. After, the progression of the curve can be restarted.

Procedure

- In *Trend curve* view, activate a curve with the arrow button Up.

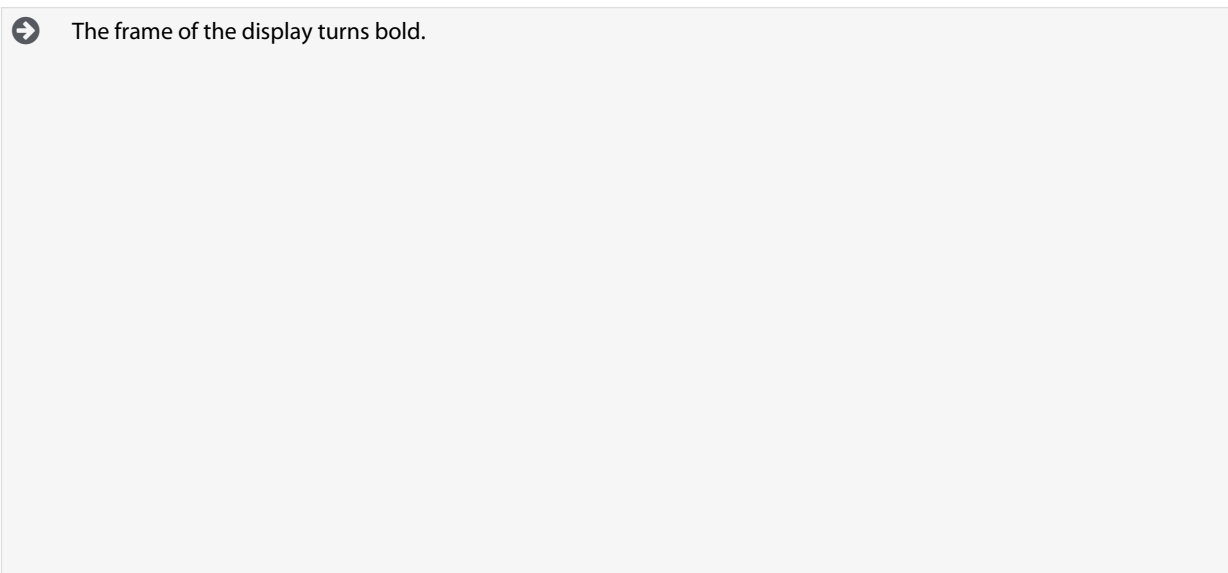

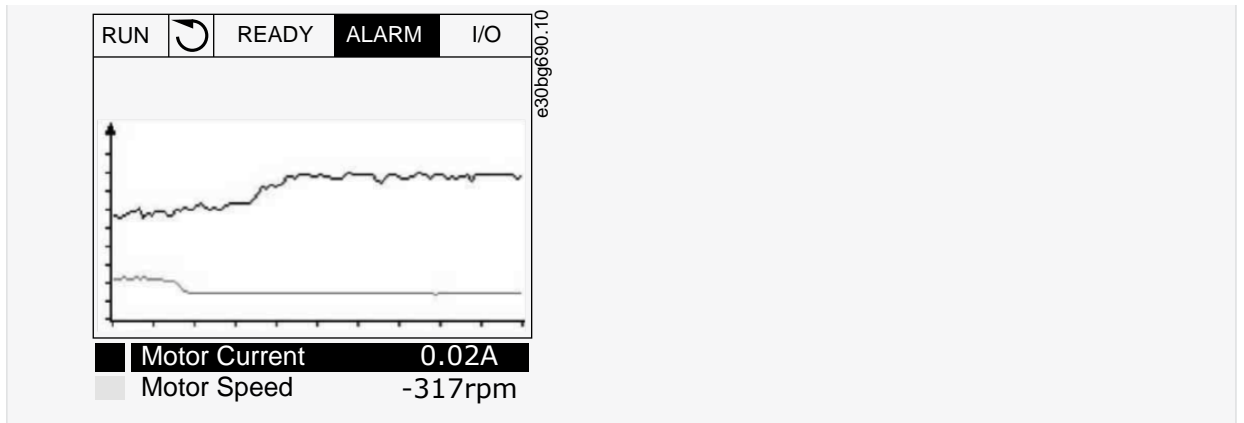

2. Push [OK] at the target point of the curve.

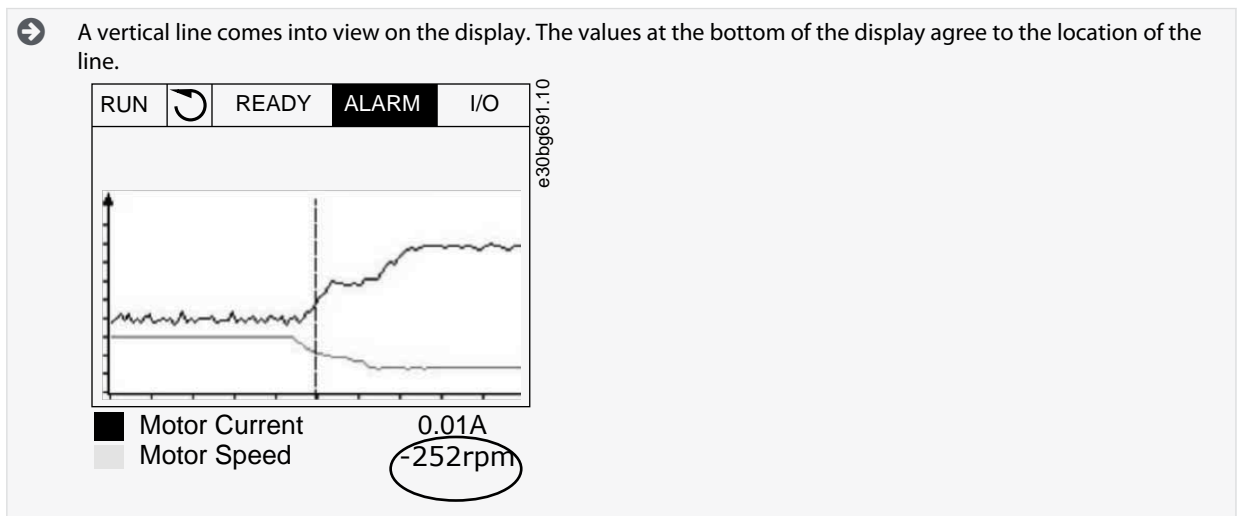

3. To move the line to see the values of some other location, use the arrow buttons Left and Right.

5.3.4 Trend Curve Parameters

Table 13: The Trend Curve Parameters

Index	Parameter	Min	Max	Unit	Default	ID	Description
M2.2.1	View Trend curve						Go into this menu to monitor values in a curve form.
P2.2.2	Sampling interval	100	432000	ms	100	2368	
P2.2.3	Channel 1 min	-214748	1000		-1000	2369	
P2.2.4	Channel 1 max	-1000	214748		1000	2370	
P2.2.5	Channel 2 min	-214748	1000		-1000	2371	
P2.2.6	Channel 2 max	-1000	214748		1000	2372	
P2.2.7	Autoscale	0	1		0	2373	0 = Disabled 1 = Enabled

5.4 Basic Monitoring

5.4.1 Uses of the Basic Monitoring

Only the standard I/O board statuses are available in the Monitor menu. For the statuses of all the I/O board signals as raw data, see the I/O and Hardware menu.

Check the statuses of the expander I/O board in the I/O and Hardware menu when the system asks.

5.4.2 Basic Monitoring Parameters

Table 14: Items in the Basic Monitoring Menu

Index	Monitoring value	Unit	Scale	ID	Description
V2.3.1	Output frequency	Hz	0.01	1	
V2.3.2	Frequency reference	Hz	0.01	25	
V2.3.3	Motor speed	RPM	1	2	
V2.3.4	Motor current	A	Varies	3	
V2.3.5	Motor torque	%	0.1	4	
V2.3.7	Motor shaft power	%	0.1	5	
V2.3.8	Motor shaft power	kW/hp	Varies	73	
V2.3.9	Motor voltage	V	0.1	6	
V2.3.10	DC-link voltage	V	1	7	
V2.3.11	Unit temperature	°C	0.1	8	
V2.3.12	Motor temperature	%	0.1	9	
V2.3.13	Motor Preheat		1	1228	0 = OFF 1 = Heating (feeding DC-current)
V2.3.15	kWh Trip Counter Low	kWh	1	1054	
V2.3.14	kWh Trip Counter High		1	1067	

5.5 I/O Monitoring

Table 15: I/O Signal Monitoring

Index	Monitoring value	Unit	Scale	ID	Description
V2.4.1	Slot A DIN 1, 2, 3		1	15	
V2.4.2	Slot A DIN 4, 5, 6		1	16	
V2.4.3	Slot B RO 1, 2, 3		1	17	
V2.4.4	Analog input 1	%	0.01	59	Slot A.1 as default.
V2.4.5	Analog input 2	%	0.01	60	Slot A.2 as default.
V2.4.6	Analog input 3	%	0.01	61	Slot D.1 as default.
V2.4.7	Analog input 4	%	0.01	62	Slot D.2 as default.
V2.4.8	Analog input 5	%	0.01	75	Slot E.1 as default.
V2.4.9	Analog input 6	%	0.01	76	Slot E.2 as default.
V2.4.10	Slot A AO1	%	0.01	81	

5.6 Temperature Inputs

Table 16: Monitoring the Temperature Inputs

Index	Monitoring value	Unit	Scale	ID	Description
V2.5.1 ⁽¹⁾	Temperature input 1	°C	0.1	50	
V2.5.2 ⁽¹⁾	Temperature input 2	°C	0.1	51	
V2.5.3 ⁽¹⁾	Temperature input 3	°C	0.1	52	
V2.5.4 ⁽¹⁾	Temperature input 4	°C	0.1	69	
V2.5.5 ⁽¹⁾	Temperature input 5	°C	0.1	70	
V2.5.6 ⁽¹⁾	Temperature input 6	°C	0.1	71	

¹ This parameter group is visible with an option board for temperature measurement (OPTBH).

5.7 Extras and Advanced

Table 17: Monitoring of the Advanced Values

Index	Monitoring value	Unit	Scale	ID	Description
V2.6.1	Drive Status Word		1	43	B1 = Ready B2 = Run B3 = Fault B6 = Run Enable B7 = Alarm Active B10 = DC current in stop B11 = DC brake active B12 = Run Request B13 = Motor Regulator Active B15 = Brake Chopper Active
V2.6.2	Ready status		1	78	B0 = Run Enable high B1 = No fault active B2 = Charge switch closed B3 = DC voltage OK B4 = Power unit OK B5 = Power unit is not blocking start B6 = System software is not blocking start
V2.6.3	Application Status Word1		1	89	B0 = Interlock 1 B1 = Interlock 2 B2 = Ramp 2 active B3 = Reserved B4 = I/O A control active B5 = I/O B control active B6 = Fieldbus Control Active B7 = Local control active B8 = PC control active B9 = Preset frequencies active B10 = Flushing active B11 = Fire Mode active

Index	Monitoring value	Unit	Scale	ID	Description
					B12 = Motor Preheat active B13 = Quick stop active B14 = Drive stopped from keypad
V2.6.4	Application Status Word2		1	90	B0 = Acc/Dec prohibited B1 = Motor switch open B2 = PID running B3 = PID sleep B4 = PID soft fil B5 = Autocleaning active B6 = Jockey pump B7 = Priming pump B8 = Anti-blocking B9 = Input pressure alarm B10 = Frost protection alarm B11 = Overpressure alarm B14 = Supervision 1 B15 = Supervision 2
V2.6.5	DIN Status Word 1		1	56	
V2.6.6	DIN Status Word 2		1	57	
V2.6.7	Motor current 1 decimal		0.1	45	
V2.6.8	Frequency reference source		1	1495	0 = PC 1 = Preset Freqs 2 = Keypad Reference 3 = Fieldbus 4 = AI1 5 = AI2 6 = AI1+AI2 7 = PID Controller 8 = Motor Potentiom. 10 = Flushing 11 = Block Out.1 12 = Block Out.2 13 = Block Out.3 14 = Block Out.4 15 = Block Out.5 16 = Block Out.6 17 = Block Out.7 18 = Block Out.8 19 = Block Out.9 20 = Block Out.10 100 = Not defined 101 = Alarm, PresetFreq 102 = Auto-cleaning
V2.6.9	Last active fault code		1	37	
V2.6.10	Last active fault ID		1	95	

Index	Monitoring value	Unit	Scale	ID	Description
V2.6.11	Last active alarm code		1	74	
V2.6.12	Last active alarm ID		1	94	
V2.6.13	Motor regulator status		1	77	B0 = Current Limit (Motor) B1 = Current Limit (Generator) B2 = Torque Limit (Motor) B3 = Torque Limit (Generator) B4 = Overvoltage Control B5 = Undervoltage Control B6 = Power Limit (Motor) B7 = Power Limit (Generator)
V2.6.14	Motor Shaft Power 1 Decimal	kW/hp		98	

5.8 Timer Functions Monitoring

Table 18: Monitoring of the Timer Functions

Index	Monitoring value	Unit	Scale	ID	Description
V2.7.1	TC 1, TC 2, TC 3		1	1441	
V2.7.2	Interval 1		1	1442	
V2.7.3	Interval 2		1	1443	
V2.7.4	Interval 3		1	1444	
V2.7.5	Interval 4		1	1445	
V2.7.6	Interval 5		1	1446	
V2.7.7	Timer 1	s	1	1447	
V2.7.8	Timer 2	s	1	1448	
V2.7.9	Timer 3	s	1	1449	
V2.7.10	Real-time clock			1450	

5.9 PID Controller Monitoring

Table 19: Monitoring of the Values of the PID Controller

Index	Monitoring value	Unit	Scale	ID	Description
V2.8.1	PID setpoint	Varies	As is set in P3.13.1.7 (See 6.13 Group 3.13: PID Controller.)	20	
V2.8.2	PID feedback	Varies	As is set in P3.13.1.7	21	
V2.8.3	PID Feedback (1)	Varies	As is set in P3.13.1.7	15541	
V2.8.4	PID Feedback (2)	Varies	As is set in P3.13.1.7	15542	

Index	Monitoring value	Unit	Scale	ID	Description
V2.8.5	PID Error	Varies	As is set in P3.13.1.7	22	
V2.8.6	PID Output	%	0.01	23	
V2.8.7	PID Status		1	24	0 = Stopped 1 = Running 3 = Sleep mode 4 = In dead band (see 6.13 Group 3.13: PID Controller)

5.10 External PID Controller Monitoring

Table 20: Monitoring of the Values of the External PID Controller

Index	Monitoring value	Unit	Scale	ID	Description
V2.9.1	ExtPID Setpoint	Varies	As set in P3.14.1.10 (See 6.14 Group 3.14: External PID Controller.)	83	
V2.9.2	ExtPID Feedback	Varies	As set in P3.14.1.10	84	
V2.9.3	ExtPID Error	Varies	As set in P3.14.1.10	85	
V2.9.4	ExtPID Output	%	0.01	86	
V2.9.5	ExtPID Status		1	87	0 = Stopped 1 = Running 2 = In dead band (See 6.14 Group 3.14: External PID Controller.)

5.11 Multi-pump Monitoring

Table 21: Multi-pump Monitoring

Index	Monitoring value	Unit	Scale	ID	Description
V2.10.1	Motors Running		1	30	
V2.10.2	Autochange		1	1114	
V2.10.3	Next Autochange	h	0.1	1503	
V2.10.4	Operate Mode		1	1505	0 = Slave 1 = Master
V2.10.5	Multi-pump Status		1	1628	0 = Not used 10 = Stopped 20 = Sleep 30 = Anti-blocking 40 = Auto-cleaning 50 = Flushing 60 = Soft filling 70 = Regulating 80 = Following 90 = Const. producing 200 = Unknown
V2.10.6	CommunicationStatus	h	0.1	1629	0 = Not used (Multi-pump multidrive function) 10 = Fatal communication errors occurred (or no communication) 11 = Errors occurred (data sending)

Index	Monitoring value	Unit	Scale	ID	Description
					12 = Errors occurred (data receiving) 20 = Communication operational, no errors occurred 30 = Status unknown
V2.10.7	Pump (1) RunningTime	h	0.1	1620	
V2.10.8	Pump 2 RunningTime	h	0.1	1621	
V2.10.9	Pump 3 RunningTime	h	0.1	1622	
V2.10.10	Pump 4 RunningTime	h	0.1	1623	
V2.10.11	Pump 5 RunningTime	h	0.1	1624	
V2.10.12	Pump 6 RunningTime	h	0.1	1625	
V2.10.13	Pump 7 RunningTime	h	0.1	1626	
V2.10.14	Pump 8 RunningTime	h	0.1	1627	

5.12 Monitoring of Maintenance Counters

Table 22: Maintenance Counter Monitoring

Index	Monitoring value	Unit	Scale	ID	Description
V2.11.1	Maintenance Counter 1	h/kRev	Varies	1101	

5.13 Fieldbus Process Data Monitoring

Table 23: Fieldbus Process Data Monitoring

Index	Monitoring value	Unit	Scale	ID	Description
V2.12.1	FB Control Word			874	
V2.12.2	FB Status Word			864	
V2.12.3	FB Speed Reference			875	
V2.12.4	FB Speed Actual			865	
V2.12.5	Fieldbus General Control Word			861	
V2.12.6	Fieldbus General Status Word			862	

Table 24: Fieldbus Data In

Index	Monitoring value	Unit	Scale	ID	Description
V2.12.7.1	FB Data In 1		1	876	
V2.12.7.2	FB Data In 2		1	877	
V2.12.7.3	FB Data In 3		1	878	
V2.12.7.4	FB Data In 4		1	879	
V2.12.7.5	FB Data In 5		1	880	
V2.12.7.6	FB Data In 6		1	881	

Index	Monitoring value	Unit	Scale	ID	Description
V2.12.7.7	FB Data In 7		1	882	
V2.12.7.8	FB Data In 8		1	883	
V2.12.7.9	FB Data In 9		1	229	
V2.12.7.10	FB Data In 10		1	230	
V2.12.7.11	FB Data In 11		1	231	
V2.12.7.12	FB Data In 12		1	232	
V2.12.7.13	FB Data In 13		1	233	
V2.12.7.14	FB Data In 14		1	234	
V2.12.7.15	FB Data In 15		1	235	
V2.12.7.16	FB Data In 16		1	236	

Table 25: Fieldbus Data Out

Index	Monitoring value	Unit	Scale	ID	Description
V2.12.8.1	FB Data Out 1		1	866	
V2.12.8.2	FB Data Out 2		1	867	
V2.12.8.3	FB Data Out 3		1	868	
V2.12.8.4	FB Data Out 4		1	869	
V2.12.8.5	FB Data Out 5		1	870	
V2.12.8.6	FB Data Out 6		1	871	
V2.12.8.7	FB Data Out 7		1	872	
V2.12.8.8	FB Data Out 8		1	873	
V2.12.8.9	FB Data Out 9		1	245	
V2.12.8.10	FB Data Out 10		1	246	
V2.12.8.11	FB Data Out 11		1	247	
V2.12.8.12	FB Data Out 12		1	248	
V2.12.8.13	FB Data Out 13		1	249	
V2.12.8.14	FB Data Out 14		1	250	
V2.12.8.15	FB Data Out 15		1	251	
V2.12.8.16	FB Data Out 16		1	252	

5.14 Drive Customizer Monitoring

Table 26: Drive Customizer Monitoring

Index	Monitoring value	Unit	Scale	ID	Description
V2.13.2	Block Out.1			15020	
V2.13.3	Block Out.2			15040	
V2.13.4	Block Out.3			15060	
V2.13.5	Block Out.4			15080	
V2.13.6	Block Out.5			15100	
V2.13.7	Block Out.6			15120	
V2.13.8	Block Out.7			15140	
V2.13.9	Block Out.8			15160	
V2.13.10	Block Out.9			15180	
V2.13.11	Block Out.10			15200	

5.15 Condition-based Monitoring

Table 27: Condition-based Monitoring

Index	Name	Min	Max	Unit	Default	ID	Description
V2.16.1 Baseline Data							
V2.16.1.1	BaselineDataElem1	-300.00	320.00	various	0.00	3601	
V2.16.1.2	BaselineDataElem2	-300.00	320.00	various	0.00	3602	
V2.16.1.3	BaselineDataElem3	-300.00	320.00	various	0.00	3603	
V2.16.1.4	BaselineDataElem4	-300.00	320.00	various	0.00	3604	
V2.16.1.5	BaselineDataElem5	-300.00	320.00	various	0.00	3605	
V2.16.1.6	BaselineDataElem6	-300.00	320.00	various	0.00	3606	
V2.16.1.7	BaselineDataElem7	-300.00	320.00	various	0.00	3607	
V2.16.1.8	BaselineDataElem8	-300.00	320.00	various	0.00	3608	
V2.16.1.9	BaselineDataElem9	-300.00	320.00	various	0.00	3609	
V2.16.1.10	BaselineDataElem10	-300.00	320.00	various	0.00	3610	
V2.16.1.11	BaselineRun Status	0	14		0	3622	0=Not Started 1=Running 2=Running 10% 3=Running 20% 4=Running 30% 5=Running 40% 6=Running 50% 7=Running 60% 8=Running 70% 9=Running 80%

Index	Name	Min	Max	Unit	Default	ID	Description
							10=Running 90% 11=Completed 12=Run Failed 13=Manual Before Baseline 14=Manual After Baseline
V2.16.2 Stator Winding Monitor							
V2.16.2.1	Current Unbalance	0.00	100.00	%	0.00	3617	
V2.16.2.2	Current Threshold Value	0.00	100.00	%	0.00	3620	
V2.16.2.3	Current Warning S1 High Threshold	0.00	100.00	%	0.00	3611	
V2.16.2.4	Current Warning S2 High Threshold	0.00	100.00	%	0.00	3612	
V2.16.2.5	Current Alarm High Threshold	0.00	100.00	%	0.00	3613	
V2.16.3 Vibration							
V2.16.3.1	Vibration	0.00	100.00	%	0.00	3623	
V2.16.3.2	Vibration Threshold Value	0.00	100.00	%	0.00	3624	
V2.16.3.3	Vibration Warning S1 High Threshold	0.00	100.00	%	0.00	3625	
V2.16.3.4	Vibration Warning S2 High Threshold	0.00	100.00	%	0.00	3626	
V2.16.3.5	Vibration Alarm High Threshold	0.00	100.00	%	0.00	3627	
V2.16.4 Load							
V2.16.4.1	Motor Torque	-300.0	300.0	%	0.0	4	
V2.16.4.2	Load Threshold Value	-300.0	300.0	%	0.00	3628	
V2.16.4.3	Load Warning S1 High Threshold	-300.0	300.0	%	0.00	3629	
V2.16.4.4	Load Warning S2 High Threshold	-300.0	300.0	%	0.00	3630	
V2.16.4.5	Load Alarm High Threshold	-300.0	300.0	%	0.00	3631	
V2.16.4.6	Load Warning S1 Low Threshold	-300.0	300.0	%	0.00	3632	
V2.16.4.7	Load Warning S2 Low Threshold	-300.0	300.0	%	0.00	3633	
V2.16.4.8	Load Alarm Low Threshold	-300.0	300.0	%	0.00	3634	
V2.16.5	Condition Based Monitoring Status	0	65535		0	3619	B0= Stator current warning S1 B2= Vibration warning S1 B3= Load warning S1 B5= Stator current warning S2 B7= Vibration warning S2 B8= Load warning S2 B10= Stator current alarm/fault B12= Vibration alarm/fault

Index	Name	Min	Max	Unit	Default	ID	Description
							B13= Load alarm/fault

6 Parameters Menu

6.1 Group 3.1: Motor Settings

Table 28: Motor Nameplate Parameters

Index	Parameter	Min	Max	Unit	Default	ID	Description
P3.1.1.1	Motor Nominal Voltage	Varies	Varies	V	Varies	110	
P3.1.1.2	Motor Nominal Frequency	8.00	320.00	Hz	50 / 60	111	
P3.1.1.3	Motor Nominal Speed	24	19200	rpm	Varies	112	
P3.1.1.4	Motor Nominal Current	IH * 0.1	IH * 2	A	Varies	113	
P3.1.1.5	Motor Cos Phi (Power Factor)	0.30	1.00		Varies	120	
P3.1.1.6	Motor Nominal Power	Varies	Varies	kW	Varies	116	

Table 29: Motor Control Settings

Index	Parameter	Min	Max	Unit	Default	ID	Description
P3.1.2.2	Motor Type	0	2		0	650	0 = Induction motor 1 = PM motor 2 = Reluctance motor
P3.1.2.3	Switching Frequency	1.5	Varies	kHz	Varies	601	
P3.1.2.4	Identification	0	2		0	631	0 = No action 1 = At standstill 2 = With rotation
P3.1.2.5	Magnetizing Current	0.0	2*IH	A	0.0	612	
P3.1.2.6	Motor Switch	0	1		0	653	0 = Disabled 1 = Enabled
P3.1.2.10	Overvoltage Control	0	1		1	607	0 = Disabled 1 = Enabled
P3.1.2.11	Undervoltage Control	0	1		1	608	0 = Disabled 1 = Enabled
P3.1.2.12	Energy Optimization	0	1		0	666	0 = Disabled 1 = Enabled
P3.1.2.13	Stator Voltage Adjust	50.0	150.0	%	100.0	659	
P3.1.2.15	Rs Voltage Drop	0.00	50.00	%	0.00	662	
P3.1.2.16	Ls Voltage Drop	0.00	200.00	%	0.00	673	
P3.1.2.17	Motor BEM Voltage	0	Varies	V	0	674	

Table 30: Motor Limit Settings

Index	Parameter	Min	Max	Unit	Default	ID	Description
P3.1.3.1	Motor Current Limit	IH*0.1	IS	A	Varies	107	
P3.1.3.2	Motor Torque Limit	0.0	300.0	%	300.0	1287	

Table 31: Open Loop Settings

Index	Parameter	Min	Max	Unit	Default	ID	Description
P3.1.4.1	U/f Ratio	0	2		0	108	0 = Linear 1 = Squared 2 = Programmable
P3.1.4.2	Field Weakening Point Frequency	8.00	P3.3.1.2	Hz	Varies	602	
P3.1.4.3	Voltage at Field Weakening Point	10.00	200.00	%	100.00	603	
P3.1.4.4	U/f Midpoint Frequency	0.00	P3.1.4.2	Hz	Varies	604	
P3.1.4.5	U/f Midpoint Voltage	0.0	100.0	%	100.00	605	
P3.1.4.6	Zero Frequency Voltage	0.00	40.00	%	Varies	606	
P3.1.4.7	Flying Start Options	0	255		0	1590	B0 = Search the shaft frequency only from the same direction as the frequency reference B1 = Disable AC scanning B4 = Use the frequency reference for the initial guess B5 = Disable DC pulses B6 = Flux build with current control B7 = Reverse injection direction
P3.1.4.8	Flying Start Scan Current	0.0	100.0	%	Varies	1610	
P3.1.4.9	Start Boost	0	1		0	109	0 = Disabled 1 = Enabled
M3.1.4.12	I/f Start	This menu includes 3 parameters. See Table 32 .					

Table 32: I/f Start Parameters

Index	Parameter	Min	Max	Unit	Default	ID	Description
P3.1.4.12.1	I/f Start	0	1		0	534	0 = Disabled 1 = Enabled
P3.1.4.12.2	I/f Start Frequency	5.0	0.5 * P3.1.1.2		0.2 * P3.1.1.2	535	
P3.1.4.12.3	I/f Start Current	0.0	150.0	%	80.0	536	

Table 33: Torque Stabilator Parameters

Index	Parameter	Min	Max	Unit	Default	ID	Description
P3.1.4.13.1	Torque Stabilator Gain	0.0	500.0	%	50.0	1412	
P3.1.4.13.2	Torque Stabilator Gain at Field Weakening Point	0.0	500.0	%	50.0	1414	
P3.1.4.13.3	Torque Stabilator Damping Time Constant	0.0005	1.0000	s	0.0050	1413	
P3.1.4.13.4	Torque Stabilator Damping Time Constant for PM motors	0.0005	1.0000	s	0.0500	1735	
P3.1.4.13.5	Torque Stabilator Filter Time Constant	0.0000	0.5000	s	0.0005	15650	
P3.1.4.13.6	Torque Stabilator Filter Time Constant for PM motors	0.0000	0.5000	s	0.0005	15651	

6.2 Group 3.2: Start/Stop Setup

Table 34: Start/Stop Setup

Index	Parameter	Min	Max	Unit	Default	ID	Description
P3.2.1	Remote Control Place	0	1		0 ⁽¹⁾	172	0 = I/O control 1 = Fieldbus control
P3.2.2	Local/Remote	0	1		0 ⁽¹⁾	211	0 = Remote 1 = Local
P3.2.3	Keypad Stop Button	0	1		0	114	0 = Yes 1 = No
P3.2.4	Start Function	0	1		0	505	0 = Ramping 1 = Flying start
P3.2.5	Stop Function	0	1		0	506	0 = Coasting 1 = Ramping
P3.2.6	I/O A Start/Stop Logic	0	4		2 ⁽¹⁾	300	Logic = 0 <ul style="list-style-type: none"> Ctrl sgn 1 = Forward Ctrl sgn 2 = Backward Logic = 1 <ul style="list-style-type: none"> Ctrl sgn 1 = Forward (edge) Ctrl sgn 2 = Inverted Stop Ctrl sgn 3 = Bckwrđ (edge) Logic = 2 <ul style="list-style-type: none"> Ctrl sgn 1 = Forward (edge) Ctrl sgn 2 = Bckwrđ (edge) Logic = 3 <ul style="list-style-type: none"> Ctrl sgn 1 = Start Ctrl sgn 2 = Reverse Logic = 4

Index	Parameter	Min	Max	Unit	Default	ID	Description
							<ul style="list-style-type: none"> Ctrl sgn 1 = Start (edge) Ctrl sgn 2 = Reverse
P3.2.7	I/O B Start/Stop Logic	0	4		2 ⁽¹⁾	363	See P3.2.6.
P3.2.8	Fieldbus Start Logic	0	1		0	889	0 = A rising edge is necessary 1 = State
P3.2.9	Start Delay	0.000	60.000	s	0.000	524	
P3.2.10	Remote to Local Function	0	2		2	181	0 = Keep Run 1 = Keep Run & Reference 2 = Stop
P3.2.11	Restart Delay	0.0	20.0	min	0.0	15555	0 = Not used

¹ The selection of the application with parameter P1.2 Application gives the default value. See [11.25 Default Values of Parameters in the Different Applications.](#)

6.3 Group 3.3: References

Table 35: Frequency Reference Parameters

Index	Parameter	Min	Max	Unit	Default	ID	Description
P3.3.1.1	Minimum Frequency Reference	0.00	P3.3.1.2	Hz	0.00	101	
P3.3.1.2	Maximum Frequency Reference	P3.3.1.1	320.00	Hz	50.00/60.00	102	
P3.3.1.3	Positive Frequency Reference Limit	-320.0	320.0	Hz	320.00	1285	
P3.3.1.4	Negative Frequency Reference Limit	-320.0	320.0	Hz	-320.00	1286	
P3.3.1.5	I/O Control Reference A Selection	1	20		6 ⁽¹⁾	117	1 = Preset Frequency 0 2 = Keypad reference 3 = Fieldbus 4 = AI1 5 = AI2 6 = AI1+AI2 7 = PID reference 8 = Motor potentiometer 11 = Block Out.1 12 = Block Out.2 13 = Block Out.3 14 = Block Out.4 15 = Block Out.5 16 = Block Out.6 17 = Block Out.7 18 = Block Out.8 19 = Block Out.9 20 = Block Out.10

Index	Parameter	Min	Max	Unit	Default	ID	Description
P3.3.1.6	I/O Control Reference B Selection	1	20		4 ⁽¹⁾	131	See P3.3.1.5.
P3.3.1.7	Keypad Control Reference Selection	1	20		2 ⁽¹⁾	121	1 = Preset Frequency 0 2 = Keypad reference 3 = Fieldbus 4 = AI1 5 = AI2 6 = AI1+AI2 7 = PID reference 8 = Motor potentiometer 11 = Block Out.1 12 = Block Out.2 13 = Block Out.3 14 = Block Out.4 15 = Block Out.5 16 = Block Out.6 17 = Block Out.7 18 = Block Out.8 19 = Block Out.9 20 = Block Out.10
P3.3.1.8	Keypad Reference	0.00	P3.3.1.2	Hz	0.00	184	
P3.3.1.9	Keypad Direction	0	1		0	123	0 = Forward 1 = Reverse
P3.3.1.10	Fieldbus Control Reference Selection	1	20		3 ⁽¹⁾	122	1 = Preset Frequency 0 2 = Keypad reference 3 = Fieldbus 4 = AI1 5 = AI2 6 = AI1+AI2 7 = PID reference 8 = Motor potentiometer 11 = Block Out.1 12 = Block Out.2 13 = Block Out.3 14 = Block Out.4 15 = Block Out.5 16 = Block Out.6 17 = Block Out.7 18 = Block Out.8 19 = Block Out.9 20 = Block Out.10

¹ The selection of the application with parameter P1.2 Application gives the default value. See the default values in [11.25 Default Values of Parameters in the Different Applications](#).

Table 36: Preset Frequency Parameters

Index	Parameter	Min	Max	Unit	Default	ID	Description
P3.3.3.1	Preset Frequency Mode	0	1		0 ⁽¹⁾	182	0 = Binary coded 1 = Number of inputs
P3.3.3.2	Preset Frequency 0	P3.3.1.1	P3.3.1.2	Hz	5.00	180	
P3.3.3.3	Preset Frequency 1	P3.3.1.1	P3.3.1.2	Hz	10.00 ⁽¹⁾	105	
P3.3.3.4	Preset Frequency 2	P3.3.1.1	P3.3.1.2	Hz	15.00 ⁽¹⁾	106	
P3.3.3.5	Preset Frequency 3	P3.3.1.1	P3.3.1.2	Hz	20.00 ⁽¹⁾	126	
P3.3.3.6	Preset Frequency 4	P3.3.1.1	P3.3.1.2	Hz	25.00 ⁽¹⁾	127	
P3.3.3.7	Preset Frequency 5	P3.3.1.1	P3.3.1.2	Hz	30.00 ⁽¹⁾	128	
P3.3.3.8	Preset Frequency 6	P3.3.1.1	P3.3.1.2	Hz	40.00 ⁽¹⁾	129	
P3.3.3.9	Preset Frequency 7	P3.3.1.1	P3.3.1.2	Hz	50.00 ⁽¹⁾	130	
P3.3.3.10	Preset Frequency Selection 0				DigIN SlotA.4	419	
P3.3.3.11	Preset Frequency Selection 1				DigIN SlotA.5	420	
P3.3.3.12	Preset Frequency Selection 2				DigIN Slot0.1	421	

¹ The selection of the application with parameter P1.2 Application gives the default value. See the default values in [11.25 Default Values of Parameters in the Different Applications](#).

Table 37: Motor Potentiometer Parameters

Index	Parameter	Min	Max	Unit	Default	ID	Description
P3.3.4.1	Motor Potentiometer UP				DigIN Slot0.1	418	OPEN = Not active CLOSED = Active
P3.3.4.2	Motor Potentiometer DOWN				DigIN Slot0.1	417	OPEN = Not active CLOSED = Active
P3.3.4.3	Motor Potentiometer Ramp Time	0.1	500.0	Hz/s	10.0	331	
P3.3.4.4	Motor Potentiometer Reset	0	2		1	367	0 = No reset 1 = Reset if stopped 2 = Reset if powered down

Table 38: Flushing Parameters

Index	Parameter	Min	Max	Unit	Default	ID	Description
P3.3.6.1	Flushing ReferenceActivation				DigINSlot0.1 *	530	
P3.3.6.2	Flushing reference	-MaxRef	MaxRef	Hz	0.00 *	1239	

6.4 Group 3.4: Ramps and Brakes Setup

Table 39: Ramp 1 Setup

Index	Parameter	Min	Max	Unit	Default	ID	Description
P3.4.1.1	Ramp 1 Shape	0.0	100.0	%	0.0	500	
P3.4.1.2	Acceleration Time 1	0.1	3000.0	s	5.0	103	
P3.4.1.3	Deceleration Time 1	0.1	3000.0	s	5.0	104	

Table 40: Ramp 2 Setup

Index	Parameter	Min	Max	Unit	Default	ID	Description
P3.4.2.1	Ramp 2 Shape	0.0	100.0	%	0.0	501	
P3.4.2.2	Acceleration Time 2	0.1	3000.0	s	10.0	502	
P3.4.2.3	Deceleration Time 2	0.1	3000.0	s	10.0	503	
P3.4.2.4	Ramp 2 Selection	Varies	Varies		DigIN Slot0.1	408	OPEN = Ramp 1 Shape, Acceleration Time 1 and Deceleration Time 1. CLOSED = Ramp 2 Shape, Acceleration Time 2 and Deceleration Time 2.
P3.4.2.5	Ramp 2 Threshold Frequency	0.0	P3.3.1.2	Hz	0.0	533	0 = Not used

Table 41: Start Magnetization Parameters

Index	Parameter	Min	Max	Unit	Default	ID	Description
P3.4.3.1	Start Magnetizing Current	0.00	IL	A	IH	517	0 = Disabled
P3.4.3.2	Start Magnetizing Time	0.00	600.00	s	0.00	516	

Table 42: DC Brake Parameters

Index	Parameter	Min	Max	Unit	Default	ID	Description
P3.4.4.1	DC Brake Current	0	IL	A	IH	507	0 = Disabled
P3.4.4.2	DC Braking Time at Stop	0.00	600.00	s	0.00	508	0 = DC braking not used
P3.4.4.3	Frequency to Start DC Braking at Ramp Stop	0.10	10.00	Hz	1.50	515	

Table 43: Flux Braking Parameters

Index	Parameter	Min	Max	Unit	Default	ID	Description
P3.4.5.1	Flux Braking	0	1		0	520	0 = Disabled 1 = Enabled
P3.4.5.2	Flux Braking Current	0	IL	A	IH	519	

6.5 Group 3.5: I/O Configuration

Table 44: Digital Input Settings

Index	Parameter	Min	Max	Unit	Default	ID	Description
P3.5.1.1	Control Signal 1 A				DigIN SlotA.1 ⁽¹⁾	403	
P3.5.1.2	Control Signal 2 A				DigIN SlotA.2 ⁽¹⁾	404	
P3.5.1.3	Control Signal 3 A				DigIN Slot0.1	434	
P3.5.1.4	Control Signal 1 B				DigIN Slot0.1 ⁽¹⁾	423	
P3.5.1.5	Control Signal 2 B				DigIN Slot0.1 ⁽¹⁾	424	
P3.5.1.6	Control Signal 3 B				DigIN Slot0.1	435	
P3.5.1.7	I/O B Control Force				DigIN Slot0.1 ⁽¹⁾	425	CLOSED = Force the control place to I/O B
P3.5.1.8	I/O B Reference Force				DigIN Slot0.1 ⁽¹⁾	343	CLOSED = I/O reference B (P3.3.1.6) gives the frequency reference
P3.5.1.9	Fieldbus Control Force				DigIN Slot0.1 ⁽¹⁾	411	
P3.5.1.10	Keypad Control Force				DigIN Slot0.1 ⁽¹⁾	410	
P3.5.1.11	External Fault Close				DigIN SlotA.3 ⁽¹⁾	405	OPEN = OK CLOSED = External fault
P3.5.1.12	External Fault Open				DigIN Slot0.2	406	OPEN = External fault CLOSED = OK
P3.5.1.13	Fault Reset Close				Varies	414	CLOSED = Resets all active faults
P3.5.1.14	Fault Reset Open				DigIN Slot0.1	213	OPEN = Resets all active faults
P3.5.1.15	Run Enable				DigIN Slot0.2	407	
P3.5.1.16	Run Interlock 1				DigIN Slot0.2	1041	
P3.5.1.17	Run Interlock 2				DigIN Slot0.2	1042	
P3.5.1.18	Motor Preheat ON				DigIN Slot0.1	1044	OPEN = No action CLOSED = Uses the DC current of the motor preheat in Stop state. Used when the value of P3.18.1 is 2.
P3.5.1.19	Ramp 2 Selection				DigIN Slot0.1	408	OPEN = Ramp 1 Shape, Acceleration Time 1, and Deceleration Time 1. CLOSED = Ramp 2 Shape, Acceleration Time 2, and Deceleration Time 2.
P3.5.1.20	Acc/Dec Prohibit				DigIN Slot0.1	415	

Index	Parameter	Min	Max	Unit	Default	ID	Description
P3.5.1.21	Preset Frequency Selection 0				DigIN SlotA.4 ⁽¹⁾	419	
P3.5.1.22	Preset Frequency Selection 1				Varies	420	
P3.5.1.23	Preset Frequency Selection 2				DigIN Slot0.1 ⁽¹⁾	421	
P3.5.1.24	Motor Potentiometer UP				DigIN Slot0.1	418	OPEN = Not active CLOSED = Active
P3.5.1.25	Motor Potentiometer DOWN				DigIN Slot0.1	417	OPEN = Not active CLOSED = Active
P3.5.1.26	Quick Stop Activation				Varies	1213	OPEN = Activated
P3.5.1.27	Timer 1				DigIN Slot0.1	447	
P3.5.1.28	Timer 2				DigIN Slot0.1	448	
P3.5.1.29	Timer 3				DigIN Slot0.1	449	
P3.5.1.30	PID Setpoint Boost				DigIN Slot0.1	1046	OPEN = No boost CLOSED = Boost
P3.5.1.31	PID Select Setpoint				DigIN Slot0.1 ⁽¹⁾	1047	OPEN = Setpoint 1 CLOSED = Setpoint 2
P3.5.1.32	External PID Start Signal				DigIN Slot0.2	1049	OPEN = PID2 in stop mode CLOSED = PID2 regulating
P3.5.1.33	External PID Select Setpoint				DigIN Slot0.1	1048	OPEN = Setpoint 1 CLOSED = Setpoint 2
P3.5.1.34	Reset Maintenance Counter 1				DigIN Slot0.1	490	CLOSED = Reset
P3.5.1.36	Flushing Reference Activation				DigIN Slot0.1 ⁽¹⁾	530	
P3.5.1.38	Fire Mode Activation OPEN				DigIN Slot0.2	1596	OPEN = Fire mode active CLOSED = No action
P3.5.1.39	Fire Mode Activation CLOSE				DigIN Slot0.1	1619	OPEN = No action CLOSED = Fire Mode active
P3.5.1.40	Fire Mode Reverse				DigIN Slot0.1	1618	OPEN = Forward CLOSED = Reverse
P3.5.1.41	Auto-cleaning Activation				DigIN Slot0.1	1715	
P3.5.1.42	Pump 1 Interlock				DigIN Slot0.1 ⁽¹⁾	426	OPEN = Not active CLOSED = Active
P3.5.1.43	Pump 2 Interlock				DigIN Slot0.1 ⁰	427	OPEN = Not active CLOSED = Active

Index	Parameter	Min	Max	Unit	Default	ID	Description
P3.5.1.44	Pump 3 Interlock				DigIN Slot0.1 ⁰	428	OPEN = Not active CLOSED = Active
P3.5.1.45	Pump 4 Interlock				DigIN Slot0.1	429	OPEN = Not active CLOSED = Active
P3.5.1.46	Pump 5 Interlock				DigIN Slot0.1	430	OPEN = Not active CLOSED = Active
P3.5.1.47	Pump 6 Interlock				DigIN Slot0.1	486	OPEN = Not active CLOSED = Active
P3.5.1.48	Pump 7 Interlock				DigIN Slot0.1	487	OPEN = Not active CLOSED = Active
P3.5.1.49	Pump 8 Interlock				DigIN Slot0.1	488	OPEN = Not active CLOSED = Active
P3.5.1.52	Reset kWh Trip Counter				DigIN Slot0.1	1053	
P3.5.1.53	Parameter Set 1/2 Selection				DigIN Slot0.1	496	OPEN = Parameter Set 1 CLOSED = Parameter Set 2
P3.5.1.54	Multi-Setpoint Selection 0				DigIN Slot0.1	15576	
P3.5.1.55	Multi-Setpoint Selection 1				DigIN Slot0.1	15577	
P3.5.1.56	Multi-Setpoint Selection 2				DigIN Slot0.1	15578	
P3.5.1.57	Multi-Setpoint Selection 3				DigIN Slot0.1	15579	
P3.5.1.58	Flow Switch				DigIN Slot0.2	15590	
P3.5.1.59	AHF Over Temperature				DigIN Slot0.2	15513	

¹ The selection of the application with parameter P1.2 Application gives the default value. See the default values in [11.25 Default Values of Parameters in the Different Applications](#).

NOTICE

Your option board and board setup give the number of available analogue inputs. The standard I/O board has 2 analog inputs.

Table 45: Analog Input 1 Settings

Index	Parameter	Min	Max	Unit	Default	ID	Description
P3.5.2.1.1	AI1 Signal Selection				AnIN SlotA.1 ⁽¹⁾	377	
P3.5.2.1.2	AI1 Signal Filter Time	0.00	300.00	s	0.1 ⁽¹⁾	378	
P3.5.2.1.3	AI1 Signal Range	0	1		0 ⁽¹⁾	379	0 = 0...10 V/0...20 mA 1 = 2...10 V/4...20 mA

Index	Parameter	Min	Max	Unit	Default	ID	Description
P3.5.2.1.4	AI1 Custom. Min	-160.00	160.00	%	0.00 ⁽¹⁾	380	
P3.5.2.1.5	AI1 Custom. Max	-160.00	160.00	%	100.00 ⁽¹⁾	381	
P3.5.2.1.6	AI1 Signal Inversion	0	1		0 ⁽¹⁾	387	0 = Normal 1 = Signal inverted

¹ The selection of the application with parameter P1.2 Application gives the default value. See the default values in [11.25 Default Values of Parameters in the Different Applications](#).

Table 46: Analog Input 2 Settings

Index	Parameter	Min	Max	Unit	Default	ID	Description
P3.5.2.2.1	AI2 Signal Selection				AnIN SlotA.2 ⁽¹⁾	388	See P3.5.2.1.1.
P3.5.2.2.2	AI2 Signal Filter Time	0.00	300.00	s	0.1 ⁽¹⁾	389	See P3.5.2.1.2.
P3.5.2.2.3	AI2 Signal Range	0	1		1 ⁽¹⁾	390	See P3.5.2.1.3.
P3.5.2.2.4	AI2 Custom. Min	-160.00	160.00	%	0.00 ⁽¹⁾	391	See P3.5.2.1.4.
P3.5.2.2.5	AI2 Custom. Max	-160.00	160.00	%	100.00 ⁽¹⁾	392	See P3.5.2.1.5.
P3.5.2.2.6	AI2 Signal Inversion	0	1		0 ⁽¹⁾	398	See P3.5.2.1.6.

¹ The selection of the application with parameter P1.2 Application gives the default value. See the default values in [11.25 Default Values of Parameters in the Different Applications](#).

Table 47: Analog Input 3 Settings

Index	Parameter	Min	Max	Unit	Default	ID	Description
P3.5.2.3.1	AI3 Signal Selection				AnIN SlotD.1	141	See P3.5.2.1.1.
P3.5.2.3.2	AI3 Signal Filter Time	0.00	300.00	s	0.1	142	See P3.5.2.1.2.
P3.5.2.3.3	AI3 Signal Range	0	1		0	143	See P3.5.2.1.3.
P3.5.2.3.4	AI3 Custom. Min	-160.00	160.00	%	0.00	144	See P3.5.2.1.4.
P3.5.2.3.5	AI3 Custom. Max	-160.00	160.00	%	100.00	145	See P3.5.2.1.5.
P3.5.2.3.6	AI3 Signal Inversion	0	1		0	151	See P3.5.2.1.6.

Table 48: Analog Input 4 Settings

Index	Parameter	Min	Max	Unit	Default	ID	Description
P3.5.2.4.1	AI4 Signal Selection				AnIN SlotD.2	152	See P3.5.2.1.1.
P3.5.2.4.2	AI4 Signal Filter Time	0.00	300.00	s	0.1	153	See P3.5.2.1.2.

Index	Parameter	Min	Max	Unit	Default	ID	Description
P3.5.2.4.3	AI4 Signal Range	0	1		0	154	See P3.5.2.1.3.
P3.5.2.4.4	AI4 Custom. Min	-160.00	160.00	%	0.00	155	See P3.5.2.1.4.
P3.5.2.4.5	AI4 Custom. Max	-160.00	160.00	%	100.00	156	See P3.5.2.1.5.
P3.5.2.4.6	AI4 Signal Inversion	0	1		0	162	See P3.5.2.1.6.

Table 49: Analog Input 5 Settings

Index	Parameter	Min	Max	Unit	Default	ID	Description
P3.5.2.5.1	AI5 Signal Selection				AnIN SlotE.1	188	See P3.5.2.1.1.
P3.5.2.5.2	AI5 Signal Filter Time	0.00	300.00	s	0.1	189	See P3.5.2.1.2.
P3.5.2.5.3	AI5 Signal Range	0	1		0	190	See P3.5.2.1.3.
P3.5.2.5.4	AI5 Custom. Min	-160.00	160.00	%	0.00	191	See P3.5.2.1.4.
P3.5.2.5.5	AI5 Custom. Max	-160.00	160.00	%	100.00	192	See P3.5.2.1.5.
P3.5.2.5.6	AI5 Signal Inversion	0	1		0	198	See P3.5.2.1.6.

Table 50: Analog Input 6 Settings

Index	Parameter	Min	Max	Unit	Default	ID	Description
P3.5.2.6.1	AI6 Signal Selection				AnIN SlotE.2	199	See P3.5.2.1.1.
P3.5.2.6.2	AI6 Signal Filter Time	0.00	300.00	s	0.1	200	See P3.5.2.1.2.
P3.5.2.6.3	AI6 Signal Range	0	1		0	201	See P3.5.2.1.3.
P3.5.2.6.4	AI6 Custom. Min	-160.00	160.00	%	0.00	203	See P3.5.2.1.4.
P3.5.2.6.5	AI6 Custom. Max	-160.00	160.00	%	100.00	204	See P3.5.2.1.5.
P3.5.2.6.6	AI6 Signal Inversion	0	1		0	209	See P3.5.2.1.6.

Table 51: Digital Output Settings on Standard I/O Board, Slot B

Index	Parameter	Min	Max	Unit	De- fault	ID	Description
P3.5.3.2.1	RO1 Func- tion	0	75		Varies	11001	The function selection for RO1: 0 = None 1 = Ready 2 = Run 3 = General fault 4 = General fault inverted 5 = General alarm 6 = Reversed

Index	Parameter	Min	Max	Unit	De- fault	ID	Description
							7 = At speed 8 = Thermistor fault 9 = Motor regulator active 10 = Start signal active 11 = Keypad control active 12 = I/O B control activated 13 = Limit supervision 1 14 = Limit supervision 2 15 = Fire Mode active 16 = Flushing activated 17 = Preset freq. active 18 = Quick stop activated 19 = PID in Sleep mode 20 = PID soft fill active 21 = PID feedback supervision (limits) 22 = Ext. PID supervision (limits) 23 = Input press. alarm/fault 24 = Frost prot. alarm/fault 25 = Time channel 1 26 = Time channel 2 27 = Time channel 3 28 = FB ControlWord B13 29 = FB ControlWord B14 30 = FB ControlWord B15 31 = FB Process- Data1.B0 32 = FB Process- Data1.B1 33 = FB Process- Data1.B2 34 = Maintenance alarm 35 = Maintenance fault 37 = Block 2 Out 38 = Block 3 Out 39 = Block 4 Out 40 = Block 5 Out 41 = Block 6 Out 42 = Block 7 Out 43 = Block 8 Out 44 = Block 9 Out 45 = Block 10 Out 46 = Jockey pump control 47 = Priming pump control 48 = Auto-cleaning active 49 = Multi-pump K1 control 50 = Multi-pump K2 control 51 = Multi-pump K3 control 52 = Multi-pump K4 control 53 = Multi-pump K5 control 54 = Multi-pump K6 control 55 = Multi-pump K7 control 56 = Multi-pump K8 control 69 = Selected parameter set

Index	Parameter	Min	Max	Unit	De- fault	ID	Description
							72 = AHF Cap Disconnect 73 = AHF Cap Disconnect Inv 74 = Run indication 75 = Motor Switch Open
P3.5.3.2.2	RO1 ON Delay	0.00	320.00	s	0.00	11002	
P3.5.3.2.3	RO1 OFF Delay	0.00	320.00	s	0.00	11003	
P3.5.3.2.4	RO2 Func- tion	0	56		Varies	11004	See P3.5.3.2.1.
P3.5.3.2.5	RO2 ON Delay	0.00	320.00	s	0.00	11005	See P3.5.3.2.2.
P3.5.3.2.6	RO2 OFF Delay	0.00	320.00	s	0.00	11006	See P3.5.3.2.3.
P3.5.3.2.7	RO3 Func- tion	0	56		Varies	11007	See P3.5.3.2.1. Not visible if only 2 output relays are installed.
P3.5.3.2.8	R03 ON De- lay	0.00	320.00	s	0.00	11008	See P3.5.3.2.2. Not visible if only 2 output relays are installed.
P3.5.3.2.9	R03 OFF Delay	0.00	320.00	s	0.00	11009	See P3.5.3.2.3. Not visible if only 2 output relays are installed.

The Digital Outputs of the Expander Slots C, D, and E

NOTICE

Shows only the parameters for the outputs on option boards in slots C, D, and E. Make the selections as in Basic AO1 Function (P3.5.4.1.1). This group or these parameters are not visible if there are no digital outputs in slots C, D, or E.

Table 52: Analog Output Settings on Standard I/O board

Index	Parameter	Min	Max	Unit	Default	ID	Description
P3.5.4.1.1	AO1 function	0	31		2 ⁽¹⁾	10050	0 = TEST 0% (Not used) 1 = TEST 100% 2 = Output freq (0 - fmax) 3 = Freq reference (0 - fmax) 4 = Motor speed (0 - Motor nominal speed) 5 = Output current (0 - InMotor) 6 = Motor torque (0 - TnMotor) 7 = Motor power (0 - PnMotor) 8 = Motor voltage (0 - UnMotor) 9 = DC link voltage (0-1000 V) 10 = PID Setpoint (0-100%) 11 = PID Feedback (0-100%) 12 = PID1 output (0-100%) 13 = Ext.PID output (0-100%)

Index	Parameter	Min	Max	Unit	Default	ID	Description
							14 = ProcessDataIn1 (0–100%) 15 = ProcessDataIn2 (0–100%) 16 = ProcessDataIn3 (0–100%) 17 = ProcessDataIn4 (0–100%) 18 = ProcessDataIn5 (0–100%) 19 = ProcessDataIn6 (0–100%) 20 = ProcessDataIn7 (0–100%) 21 = ProcessDataIn8 (0–100%) 22 = Block Out.1 (0–100%) 23 = Block Out.2 (0–100%) 24 = Block Out.3 (0–100%) 25 = Block Out.4 (0–100%) 26 = Block Out.5 (0–100%) 27 = Block Out.6 (0–100%) 28 = Block Out.7 (0–100%) 29 = Block Out.8 (0–100%) 30 = Block Out.9 (0–100%) 31 = Block Out.10 (0–100%)
P3.5.4.1.2	AO1 Filter Time	0.0	300.0	s	1.0 ⁽¹⁾	10051	0 = No filtering
P3.5.4.1.3	AO1 minimum	0	1		0 ⁽¹⁾	10052	
P3.5.4.1.4	AO1 minimum scale	-214748.36	214748.36	Varies	0.0 ⁽¹⁾	10053	0 = 0 mA/0 V 1 = 4 mA/2 V
P3.5.4.1.5	AO1 maximum scale	-214748.36	214748.36	Varies	0.0 ⁽¹⁾	10054	

¹ The selection of the application with parameter P1.2 Application gives the default value. See the default values in [11.25 Default Values of Parameters in the Different Applications](#).

The Analog Outputs of the Expander Slots C, D, and E

NOTICE

Shows only the parameters for the outputs on option boards in slots C, D, and E. Make the selections as in Basic AO1 Function (P3.5.4.1.1). This group or these parameters are not visible if there are no digital outputs in slots C, D, or E.

6.6 Group 3.6: Fieldbus Data

Table 53: Fieldbus Data Parameters

Index	Parameter	Min	Max	Unit	Default	ID	Description
P3.6.1	Fieldbus Data Out 1 Selection	0	35000		1	852	
P3.6.2	Fieldbus Data Out 2 Selection	0	35000		2	853	
P3.6.3	Fieldbus Data Out 3 Selection	0	35000		3	854	
P3.6.4	Fieldbus Data Out 4 Selection	0	35000		4	855	
P3.6.5	Fieldbus Data Out 5 Selection	0	35000		5	856	

Index	Parameter	Min	Max	Unit	Default	ID	Description
P3.6.6	Fieldbus Data Out 6 Selection	0	35000		6	857	
P3.6.7	Fieldbus Data Out 7 Selection	0	35000		7	858	
P3.6.8	Fieldbus Data Out 8 Selection	0	35000		37	859	
P3.6.9	Fieldbus Data Out 9 Selection	0	35000		0	890	
P3.6.10	Fieldbus Data Out 10 Selection	0	35000		0	891	
P3.6.11	Fieldbus Data Out 11 Selection	0	35000		0	892	
P3.6.12	Fieldbus Data Out 12 Selection	0	35000		0	893	
P3.6.13	Fieldbus Data Out 13 Selection	0	35000		0	894	
P3.6.14	Fieldbus Data Out 14 Selection	0	35000		0	895	
P3.6.15	Fieldbus Data Out 15 Selection	0	35000		0	896	
P3.6.16	Fieldbus Data Out 16 Selection	0	35000		0	897	
P3.6.17	FB Sign of Actual	0	2		0	888	0 = Positive 1 = Actual direction 2 = Follow reference

Table 54: The Default Values for Process Data Out in Fieldbus

Data	Default Value	Scale
Process Data Out 1	Output frequency	0.01 Hz
Process Data Out 2	Motor speed	1 RPM
Process Data Out 3	Motor current	0.1 A
Process Data Out 4	Motor torque	0.1%
Process Data Out 5	Motor power	0.1%
Process Data Out 6	Motor voltage	0.1 V
Process Data Out 7	DC link voltage	1 V
Process Data Out 8	Last active fault code	1

Example

The value 2500 for output frequency equals 25.00 Hz, because the scale is 0.01. All the monitoring values in the Monitor menu (chapter [5.1 Uses of the Monitor Menu](#)) are given the scale value.

6.7 Group 3.7: Prohibit Frequencies

Table 55: Prohibit Frequencies Parameters

Index	Parameter	Min	Max	Unit	Default	ID	Description
P3.7.1	Prohibit Frequency Range 1 Low Limit	-1.00	320.00	Hz	0.00	509	0 = Not used
P3.7.2	Prohibit Frequency Range 1 High Limit	0.00	320.00	Hz	0.00	510	0 = Not used
P3.7.3	Prohibit Frequency Range 2 Low Limit	0.00	320.00	Hz	0.00	511	0 = Not used
P3.7.4	Prohibit Frequency Range 2 High Limit	0.00	320.00	Hz	0.00	512	0 = Not used
P3.7.5	Prohibit Frequency Range 3 Low Limit	0.00	320.00	Hz	0.00	513	0 = Not used
P3.7.6	Prohibit Frequency Range 3 High Limit	0.00	320.00	Hz	0.00	514	0 = Not used
P3.7.7	Ramp Time Factor	0.1	10.0	Times	1.0	518	

6.8 Group 3.8 Supervisions

Table 56: Supervision Settings

Index	Parameter	Min	Max	Unit	Default	ID	Description
P3.8.1	Supervision #1 Item Selection	0	17		0	1431	0 = Output frequency 1 = Frequency reference 2 = Motor current 3 = Motor torque 4 = Motor power 5 = DC link voltage 6 = Analog input 1 7 = Analog input 2 8 = Analog input 3 9 = Analog input 4 10 = Analog input 5 11 = Analog input 6 12 = Temperature input 1 13 = Temperature input 2 14 = Temperature input 3 15 = Temperature input 4 16 = Temperature input 5 17 = Temperature input 6
P3.8.2	Supervision #1 Mode	0	2		0	1432	0 = Not used 1 = Low limit supervision 2 = High limit supervision
P3.8.3	Supervision #1 Limit	-50.00	50.00	Varies	25.00	1433	
P3.8.4	Supervision #1 Limit Hysteresis	0.00	50.00	Varies	5.00	1434	
P3.8.5	Supervision #2 Item Selection	0	17		1	1435	See P3.8.1

Index	Parameter	Min	Max	Unit	Default	ID	Description
P3.8.6	Supervision #2 Mode	0	2		0	1436	See P3.8.2
P3.8.7	Supervision #2 Limit	-50.00	50.00	Varies	40.00	1437	
P3.8.8	Supervision #2 Limit Hysteresis	0.00	50.00	Varies	5.00	1438	

6.9 Group 3.9: Protections

Table 57: General Protection Settings

Index	Parameter	Min	Max	Unit	Default	ID	Description
P3.9.1.2	Response to External Fault	0	3		2	701	0 = No action 1 = Alarm 2 = Fault (Stop according to stop function) 3 = Fault (Stop by coasting)
P3.9.1.3	Input Phase Fault	0	1		0	730	0 = 3-phase support 1 = 1-phase support
P3.9.1.4	Undervoltage Fault	0	1		0	727	0 = Fault stored in history 1 = Fault not stored in history
P3.9.1.5	Response to Output Phase Fault	0	3		2	702	See P3.9.1.2.
P3.9.1.6	Response to Fieldbus Communication Fault	0	5		4	733	0 = No action 1 = Alarm 2 = Alarm + preset fault frequency (P3.9.1.13) 3 = Fault (Stop according to stop function) 4 = Fault (Stop by coasting)
P3.9.1.7	Slot Communication Fault	0	3		2	734	See P3.9.1.2.
P3.9.1.8	Thermistor Fault	0	3		0	732	See P3.9.1.2.
P3.9.1.9	PID Soft Fill Fault	0	3		2	748	See P3.9.1.2.
P3.9.1.10	Response to PID Supervision Fault	0	3		2	749	See P3.9.1.2.
P3.9.1.11	Response to External PID Supervision Fault	0	3		2	757	0 = No action 1 = Alarm 2 = Fault 3 = Fault, Coast
P3.9.1.12	Earth Fault	0	3		3	703	This parameter is available only in enclosure sizes MR7, MR8, MR9, MR10, MR11, and MR12, and also MR6 600 V and 690 V.
P3.9.1.13	Preset Alarm Frequency	P3.3.1.1	P3.3.1.2	Hz	25.00	183	

Index	Parameter	Min	Max	Unit	Default	ID	Description
P3.9.1.14	Response to Safe Torque Off (STO) Fault	0	2		2	775	0 = No action 1 = Alarm 2 = Fault (Stop by coasting)
P3.9.1.17	Fieldbus Communication Fault Force Delay	0.00	320.00	s	0.00	751	
P3.9.1.18	Fieldbus Communication Fault Clear Delay	0.00	320.00	s	0.00	752	
P3.9.1.19	Unbalance Current Alarm	0	1		1	753	

Table 58: Motor Thermal Protection Settings

Index	Parameter	Min	Max	Unit	Default	ID	Description
P3.9.2.1	Motor Thermal Protection	0	3		2	704	0 = No action 1 = Alarm 2 = Fault (Stop by stop mode) 3 = Fault (Stop by coasting)
P3.9.2.2	Ambient Temperature	-20.0	100.0	°C	40.0	705	
P3.9.2.3	Zero Speed Cooling Factor	5.0	150.0	%	Varies	706	
P3.9.2.4	Motor Thermal Time Constant	1	200	min	15	707	
P3.9.2.5	Motor Thermal Loadability	10	150	%	100	708	

Table 59: Motor Stall Protection Settings

Index	Parameter	Min	Max	Unit	Default	ID	Description
P3.9.3.1	Motor Stall Fault	0	3		0	709	0 = No action 1 = Alarm 2 = Fault (Stop according to stop mode) 3 = Fault (Stop by coasting)
P3.9.3.2	Stall Current	0.00	Is	A	Varies	710	
P3.9.3.3	Stall Time Limit	1.00	120.00	s	15.00	711	
P3.9.3.4	Stall Frequency Limit	1.00	P3.3.1.2	Hz	25.00	712	

Table 60: Motor Underload Protection Settings

Index	Parameter	Min	Max	Unit	Default	ID	Description
P3.9.4.1	Underload Fault	0	3		0	713	0 = No action 1 = Alarm 2 = Fault (Stop according to stop mode)

Index	Parameter	Min	Max	Unit	Default	ID	Description
							3 = Fault (Stop by coasting)
P3.9.4.2	Underload Protection: Field Weakening Area Load	10.0	150.0	%	50.0	714	
P3.9.4.3	Underload Protection: Zero Frequency Load	5.0	150.0	%	10.0	715	
P3.9.4.4	Underload Protection: Time Limit	2.00	200.00	s	20.00	716	

Table 61: Quick Stop Settings

Index	Parameter	Min	Max	Unit	Default	ID	Description
P3.9.5.1	Quick Stop Mode	0	2		Varies	1276	0 = Coasting 1 = Quick stop deceleration time 2 = Stop according to Stop function (P3.2.5)
P3.9.5.2	Quick Stop Activation	Varies	Varies		DigIN Slot0.2	1213	OPEN = Activated
P3.9.5.3	Quick Stop Deceleration Time	0.1	300.0	s	Varies	1256	
P3.9.5.4	Response to Quick Stop Fault	0	2		Varies	744	0 = No action 1 = Alarm 2 = Fault (Stop according to Quick stop mode)

Table 62: Temperature Input Fault 1 Settings

Index	Parameter	Min	Max	Unit	Default	ID	Description
P3.9.6.1 ⁽¹⁾	Temperature Signal 1	0	63		0	739	B0 = Temperature Signal 1 B1 = Temperature Signal 2 B2 = Temperature Signal 3 B3 = Temperature Signal 4 B4 = Temperature Signal 5 B5 = Temperature Signal 6
P3.9.6.2 ⁽¹⁾	Alarm Limit 1	-30.0	200.0	°C	130.0	741	
P3.9.6.3 ⁽¹⁾	Fault Limit 1	-30.0	200.0	°C	155.0	742	
P3.9.6.4 ⁽¹⁾	Fault Limit Response 1	0	3		2	740	0 = No response 1 = Alarm 2 = Fault (Stop according to stop mode) 3 = Fault (Stop by coasting)

¹ Temperature input settings are only available if a B8 or BH option board is installed.

Table 63: Temperature Input Fault 2 Settings

Index	Parameter	Min	Max	Unit	Default	ID	Description
P3.9.6.5 ⁽¹⁾	Temperature Signal 2	0	63		0	763	B0 = Temperature Signal 1 B1 = Temperature Signal 2 B2 = Temperature Signal 3 B3 = Temperature Signal 4 B4 = Temperature Signal 5 B5 = Temperature Signal 6
P3.9.6.6 ⁽¹⁾	Alarm Limit 2	-30.0	200.0	°C	130.0	764	
P3.9.6.7 ⁽¹⁾	Fault Limit 2	-30.0	200.0	°C	155.0	765	
P3.9.6.8 ⁽¹⁾	Fault Limit Response 2	0	3		2	766	0 = No response 1 = Alarm 2 = Fault (Stop according to stop mode) 3 = Fault (Stop by coasting)

¹ Temperature input settings are only available if a B8 or BH option board is installed.

Table 64: AI Low Protection Settings

Index	Parameter	Min	Max	Unit	Default	ID	Description
P3.9.8.1	Analog Input Low Protection	0	2			767	0 = No protection 1 = Protection enabled in Run state 2 = Protection enabled in Run and Stop state
P3.9.8.2	Analog Input Low Fault	0	5		0	700	0 = No action 1 = Alarm 2 = Alarm + preset fault frequency (P3.9.1.13) 3 = Alarm + previous frequency reference 4 = Fault (Stop according to stop mode) 5 = Fault (Stop by coasting)

6.10 Group 3.10: Automatic Reset

Table 65: Automatic Reset Settings

Index	Parameter	Min	Max	Unit	Default	ID	Description
P3.10.1	Automatic Reset	0	1		0 ⁽¹⁾	731	0 = Disabled 1 = Enabled
P3.10.2	Restart Function	0	1		1	719	0 = Flying start 1 = According to P3.2.4.
P3.10.3	Wait Time	0.10	10000.00	s	0.50	717	
P3.10.4	Trial Time	0.00	10000.00	s	60.00	718	
P3.10.5	Number of Trials	1	10		4	759	

Index	Parameter	Min	Max	Unit	Default	ID	Description
P3.10.6	Autoreset: Undervoltage	0	1		1	720	0 = No 1 = Yes
P3.10.7	Autoreset: Overvoltage	0	1		1	721	0 = No 1 = Yes
P3.10.8	Autoreset: Overcurrent	0	1		1	722	0 = No 1 = Yes
P3.10.9	Autoreset: AI Low	0	1		1	723	0 = No 1 = Yes
P3.10.10	Autoreset: Unit Overtemperature	0	1		1	724	0 = No 1 = Yes
P3.10.11	Autoreset: Motor Overtemperature	0	1		1	725	0 = No 1 = Yes
P3.10.12	Autoreset: External Fault	0	1		0	726	0 = No 1 = Yes
P3.10.13	Autoreset: Underload Fault	0	1		0	738	0 = No 1 = Yes
P3.10.14	Autoreset: PID Supervision Fault	0	1		0	776	0 = No 1 = Yes
P3.10.15	Autoreset: Ext PID Supervision Fault	0	1		0	777	0 = No 1 = Yes
P3.10.16	Fault Simulation	0	65535		0	1569	

¹ The selection of the application with parameter P1.2 Application gives the default value. See [11.25 Default Values of Parameters in the Different Applications](#).

6.11 Group 3.11: Application Settings

Table 66: Application Settings

Index	Parameter	Min	Max	Unit	Default	ID	Description
P3.11.1	Password	0	9999		0	1806	
P3.11.2	C/F Selection	0	1		0 ⁽¹⁾	1197	0 = Celsius 1 = Fahrenheit
P3.11.3	kW/hp Selection	0	1		0 ⁽¹⁾	1198	0 = kW 1 = hp
P3.11.4	Multimonitor View	0	2		1	1196	0 = 2x2 sections 1 = 3x2 sections 2 = 3x3 sections

Index	Parameter	Min	Max	Unit	Default	ID	Description
P3.11.5	FUNCT Button Configuration	0	15		15	1195	B0 = Local/Remote B1 = Control Page B2 = Change Direction B3 = Quick Edit
P3.11.6	Set ParamLock	0	9999		0	1807	
P3.11.7	ParamLock Key	0	9999		0	1808	

¹ The default value in the US is 1.

6.12 Group 3.12: Timer Functions

Table 67: Interval 1

Index	Parameter	Min	Max	Unit	Default	ID	Description
P3.12.1.1	ON Time	00:00:00	23:59:59	hh:mm:ss	00:00:00	1464	
P3.12.1.2	OFF Time	00:00:00	23:59:59	hh:mm:ss	00:00:00	1465	
P3.12.1.3	Days					1466	B0 = Sunday B1 = Monday B2 = Tuesday B3 = Wednesday B4 = Thursday B5 = Friday B6 = Saturday
P3.12.1.4	Assign to Channel					1468	B0 = Time channel 1 B1 = Time channel 2 B2 = Time channel 3

Table 68: Interval 2

Index	Parameter	Min	Max	Unit	Default	ID	Description
P3.12.2.1	ON Time	00:00:00	23:59:59	hh:mm:ss	00:00:00	1469	See Interval 1.
P3.12.2.2	OFF Time	00:00:00	23:59:59	hh:mm:ss	00:00:00	1470	See Interval 1.
P3.12.2.3	Days					1471	See Interval 1.
P3.12.2.4	Assign to Channel					1473	See Interval 1.

Table 69: Interval 3

Index	Parameter	Min	Max	Unit	Default	ID	Description
P3.12.3.1	ON Time	00:00:00	23:59:59	hh:mm:ss	00:00:00	1474	See Interval 1.
P3.12.3.2	OFF Time	00:00:00	23:59:59	hh:mm:ss	00:00:00	1475	See Interval 1.
P3.12.3.3	Days					1476	See Interval 1.
P3.12.3.4	Assign to Channel					1478	See Interval 1.

Table 70: Interval 4

Index	Parameter	Min	Max	Unit	Default	ID	Description
P3.12.4.1	ON Time	00:00:00	23:59:59	hh:mm:ss	00:00:00	1479	See Interval 1.
P3.12.4.2	OFF Time	00:00:00	23:59:59	hh:mm:ss	00:00:00	1480	See Interval 1.
P3.12.4.3	Days					1481	See Interval 1.
P3.12.4.4	Assign to Channel					1483	See Interval 1.

Table 71: Interval 5

Index	Parameter	Min	Max	Unit	Default	ID	Description
P3.12.5.1	ON Time	00:00:00	23:59:59	hh:mm:ss	00:00:00	1484	See Interval 1.
P3.12.5.2	OFF Time	00:00:00	23:59:59	hh:mm:ss	00:00:00	1485	See Interval 1.
P3.12.5.3	Days					1486	See Interval 1.
P3.12.5.4	Assign to Channel					1488	See Interval 1.

Table 72: Timer 1

Index	Parameter	Min	Max	Unit	Default	ID	Description
P3.12.6.1	Duration	0	72000	s	0	1489	
P3.12.6.2	Timer 1				DigINSlot 0.1	447	
P3.12.6.3	Assign to Channel					1490	B0 = Time channel 1 B1 = Time channel 2 B2 = Time channel 3

Table 73: Timer 2

Index	Parameter	Min	Max	Unit	Default	ID	Description
P3.12.7.1	Duration	0	72000	s	0	1491	See Timer 1.
P3.12.7.2	Timer 2				DigINSlot 0.1	448	See Timer 1.
P3.12.7.3	Assign to Channel					1492	See Timer 1.

Table 74: Timer 3

Index	Parameter	Min	Max	Unit	Default	ID	Description
P3.12.8.1	Duration	0	72000	s	0	1493	See Timer 1.
P3.12.8.2	Timer 3				DigINSlot 0.1	449	See Timer 1.
P3.12.8.3	Assign to Channel					1494	See Timer 1.

6.13 Group 3.13: PID Controller

Table 75: PID Controller Basic Settings

Index	Parameter	Min	Max	Unit	Default	ID	Description
P3.13.1.1	PID Gain	0.00	1000.00	%	100.00	118	
P3.13.1.2	PID Integration Time	0.00	600.00	s	1.00	119	
P3.13.1.3	PID Derivation Time	0.00	100.00	s	0.00	132	
P3.13.1.4	Process Unit Selection	1	46		1	1036	1 = % 2 = 1/min 3 = RPM 4 = ppm 5 = pps 6 = l/s 7 = l/min 8 = l/h 9 = kg/s 10 = kg/min 11 = kg/h 12 = m ³ /s 13 = m ³ /min 14 = m ³ /h 15 = m/s 16 = mbar 17 = bar 18 = Pa 19 = kPa 20 = mVS 21 = kW

Index	Parameter	Min	Max	Unit	Default	ID	Description
							22 = °C 23 = gal/s 24 = gal/min 25 = gal/h 26 = lb/s 27 = lb/min 28 = lb/h 29 = ft ³ /s 30 = ft ³ /min 31 = ft ³ /h 32 = ft/s 33 = in wg 34 = ft wg 35 = SPI 36 = lb/in ² 37 = psig 38 = hp 39 = °F 40 = ft 41 = inch 42 = mm 43 = cm 44 = m 45 = gpm 46 = cfm
P3.13.1.5	Process Unit Min	Varies	Varies	Varies	0	1033	
P3.13.1.6	Process Unit Max	Varies	Varies	Varies	100	1034	
P3.13.1.7	Process Unit Decimals	0	4		2	1035	
P3.13.1.8	Error Inversion	0	1		0	340	0 = Normal (Feedback < Setpoint -> Increase PID output) 1 = Inverted (Feedback < Setpoint -> Decrease PID output)
P3.13.1.9	Dead Band	0.00	99999.9 9	Varies	0	1056	
P3.13.1.10	Dead Band Delay	0.00	320.00	s	0.00	1057	

Table 76: Setpoint Settings

Index	Parameter	Min	Max	Unit	Default	ID	Description
P3.13.2.1	Keypad setpoint 1	P3.13.1.5	P3.13.1.6	P3.13.1.4	0	167	
P3.13.2.2	Keypad setpoint 2	P3.13.1.5	P3.13.1.6	P3.13.1.4	0	168	

Index	Parameter	Min	Max	Unit	Default	ID	Description
P3.13.2.3	Setpoint ramp time	0.00	300.0	s	0.00	1068	
P3.13.2.4	PID setpoint boost activation	Varies	Varies		DigIN Slot0.1	1046	OPEN = No boost CLOSED = Boost
P3.13.2.5	PID select setpoint	Varies	Varies		DigIN Slot0.1 ⁽¹⁾	1047	OPEN = Setpoint 1 CLOSED = Setpoint 2
P3.13.2.6	Setpoint source 1 selection	0	32		3 ⁽¹⁾	332	0 = Not used 1 = Keypad setpoint 1 2 = Keypad setpoint 2 3 = AI1 4 = AI2 5 = AI3 6 = AI4 7 = AI5 8 = AI6 9 = ProcessDataIn1 10 = ProcessDataIn2 11 = ProcessDataIn3 12 = ProcessDataIn4 13 = ProcessDataIn5 14 = ProcessDataIn6 15 = ProcessDataIn7 16 = ProcessDataIn8 17 = Temperature input 1 18 = Temperature input 2 19 = Temperature input 3 20 = Temperature input 4 21 = Temperature input 5 22 = Temperature input 6 23 = Block Out.1 24 = Block Out.2 25 = Block Out.3 26 = Block Out.4 27 = Block Out.5 28 = Block Out.6 29 = Block Out.7 30 = Block Out.8 31 = Block Out.9 32 = Block Out.10
P3.13.2.7	Setpoint 1 minimum	-200.00	200.00	%	0.00	1069	
P3.13.2.8	Setpoint 1 maximum	-200.00	200.00	%	100.00	1070	
P3.13.2.9	Setpoint 1 boost	-2.0	2.0	x	1.0	1071	
P3.13.2.10	Setpoint source 2 selection	0	Varies		2 ⁽¹⁾	431	See P3.13.2.6.

Index	Parameter	Min	Max	Unit	Default	ID	Description
P3.13.2.11	Setpoint 2 minimum	-200.00	200.00	%	0.00	1073	See P3.13.2.7.
P3.13.2.12	Setpoint 2 maximum	-200.00	200.00	%	100.00	1074	See P3.13.2.8.
P3.13.2.13	Setpoint 2 boost	-2.0	2.0	x	1.0	1078	See P3.13.2.9.

¹ The selection of the application with parameter P1.2 Application gives the default value. See the default values in [11.25 Default Values of Parameters in the Different Applications](#).

Table 77: Feedback Settings

Index	Parameter	Min	Max	Unit	Default	ID	Description
P3.13.3.1	Feedback Function	1	9		1 ⁽¹⁾	333	1 = Only Source1 in use 2 = SQRT(Source1); (Flow=Constant x SQRT(Pressure)) 3 = SQRT(Source1 - Source 2) 4 = SQRT(Source 1) + SQRT (Source 2) 5 = Source 1 + Source 2 6 = Source 1 - Source 2 7 = MIN (Source 1, Source 2) 8 = MAX (Source 1, Source 2) 9 = MEAN (Source 1, Source 2)
P3.13.3.2	Feedback Function Gain	-1000.0	2100.0	%	100.0	1058	
P3.13.3.3	Feedback 1 Source Selection	0	30		2 ⁽¹⁾	334	0 = Not used 1 = AI1 2 = AI2 3 = AI3 4 = AI4 5 = AI5 6 = AI6 7 = ProcessDataIn1 8 = ProcessDataIn2 9 = ProcessDataIn3 10 = ProcessDataIn4 11 = ProcessDataIn5 12 = ProcessDataIn6 13 = ProcessDataIn7 14 = ProcessDataIn8 15 = Temperature input 1 16 = Temperature input 2 17 = Temperature input 3 18 = Temperature input 4 19 = Temperature input 5 20 = Temperature input 6 21 = Block Out.1 22 = Block Out.2 23 = Block Out.3 24 = Block Out.4 25 = Block Out.5 26 = Block Out.6 27 = Block Out.7

Index	Parameter	Min	Max	Unit	Default	ID	Description
							28 = Block Out.8 29 = Block Out.9 30 = Block Out.10
P3.13.3.4	Feedback 1 Minimum	-200.00	200.00	%	0.00	336	
P3.13.3.5	Feedback 1 Maximum	-200.00	200.00	%	100.00	337	
P3.13.3.6	Feedback 2 Source Selection	0	20		0	335	See P3.13.3.3.
P3.13.3.7	Feedback 2 Minimum	-200.00	200.00	%	0.00	338	See P3.13.3.4.
P3.13.3.8	Feedback 2 Maximum	-200.00	200.00	%	100.00	339	See P3.13.3.5.

¹ The selection of the application with parameter P1.2 Application gives the default value. See the default values in [11.25 Default Values of Parameters in the Different Applications](#).

Table 78: Feedforward Settings

Index	Parameter	Min	Max	Unit	Default	ID	Description
P3.13.4.1	Feedforward Function	1	9		1	1059	See P3.13.3.1.
P3.13.4.2	Feedforward Function Gain	-1000	1000	%	100.0	1060	See P3.13.3.2.
P3.13.4.3	Feedforward 1 Source Selection	0	30		0	1061	See P3.13.3.3.
P3.13.4.4	Feedforward 1 Minimum	-200.00	200.00	%	0.00	1062	See P3.13.3.4.
P3.13.4.5	Feedforward 1 Maximum	-200.00	200.00	%	100.00	1063	See P3.13.3.5.
P3.13.4.6	Feedforward 2 Source Selection	0	30		0	1064	See P3.13.3.6.
P3.13.4.7	Feedforward 2 Min	-200.00	200.00	%	0.00	1065	See P3.13.3.7.
P3.13.4.8	Feedforward 2 Max	-200.00	200.00	%	100.00	1066	See P3.13.3.8.

Table 79: Sleep Function Settings

Index	Parameter	Min	Max	Unit	Default	ID	Description
P3.13.5.1	SP1 Sleep Frequency	0.00	320.00	Hz	0.00	1016	0 = Not used
P3.13.5.2	SP1 Sleep Delay	0	3000	s	0	1017	0 = Not used
P3.13.5.3	SP1 Wake-up Level	-214748.36	214748.36	Varies	0.0000	1018	0 = Not used
P3.13.5.4	SP1 Wake-up Mode	0	1		0	1019	0 = Absolute level 1 = Relative setpoint

Index	Parameter	Min	Max	Unit	Default	ID	Description
P3.13.5.5	SP1 Sleep Boost	-99999.9 9	99999.9 9	P3.13.1.4	0	1793	
P3.13.5.6	SP1 Sleep Boost Maximum Time	1	300	s	30	1795	
P3.13.5.7	SP2 Sleep Frequency	0.00	320.00	Hz	0.00	1075	See P3.13.5.1.
P3.13.5.8	SP2 Sleep Delay	0	3000	s	0	1076	See P3.13.5.2.
P3.13.5.9	SP2 Wake-up Level	-214748. 36	214748. 36	Varies	0.0000	1077	See P3.13.5.3.
P3.13.5.10	SP2 Wake-up Mode	0	1		0	1020	0=Absolute Level 1=Relative Setpoint
P3.13.5.11	SP2 Sleep Boost	-99999.9 9	99999.9 9	P3.13.1.4	0	1794	See P3.13.5.5
P3.13.5.12	SP2 Sleep Boost Maximum Time	1	300	s	30	1796	See P3.13.5.6

Table 80: Feedback Supervision Parameters

Index	Parameter	Min	Max	Unit	Default	ID	Description
P3.13.6.1	Enable Feedback Supervision	0	1		0	735	0 = Disabled 1 = Enabled
P3.13.6.2	Upper Limit	-99999.9 9	99999.9 9	Varies	Varies	736	
P3.13.6.3	Lower Limit	-99999.9 9	99999.9 9	Varies	Varies	758	
P3.13.6.4	Delay	0	30000	s	0	737	
P3.13.6.5	Response to PID Supervision Fault	0	3		2	749	0 = No action 1 = Alarm 2 = Fault (Stop according to stop mode) 3 = Fault (Stop by coasting)

Table 81: Pressure Loss Compensation Parameters

Index	Parameter	Min	Max	Unit	Default	ID	Description
P3.13.7.1	Enable Setpoint 1	0	1		0	1189	0 = Disabled 1 = Enabled
P3.13.7.2	Setpoint 1 Max Compensation	-99999.9 9	99999.9 9	Varies	Varies	1190	
P3.13.7.3	Enable Setpoint 2	0	1		0	1191	See P3.13.7.1.
P3.13.7.4	Setpoint 2 Max Compensation	-99999.9 9	99999.9 9	Varies	Varies	1192	See P3.13.7.2.

Table 82: Soft Fill Settings

Index	Parameter	Min	Max	Unit	Default	ID	Description
P3.13.8.1	Soft Fill Function	0	2		0	1094	0 = Disabled 1 = Enabled, Level 2 = Enabled, Timeout
P3.13.8.2	Soft Fill Frequency	0.00	P3.3.1.2	Hz	0	1055	
P3.13.8.3	Soft Fill Level	-99999.99	99999.99	Varies	0.0000	1095	
P3.13.8.4	Soft Fill Timeout	0	30000	s	0	1096	0 = No timeout, no fault triggering
P3.13.8.5	D Soft Fill Fault	0	3		2	748	0 = No action 1 = Alarm 2 = Fault (Stop according to stop mode) 3 = Fault (Stop by coasting)

Table 83: Input Pressure Supervision Parameters

Index	Parameter	Min	Max	Unit	De- fault	ID	Description
P3.13.9.1	Enable Supervision	0	1		0	1685	0 = Disabled 1 = Enabled
P3.13.9.2	Supervision Signal	0	23		0	1686	0 = Analog input 1 1 = Analog input 2 2 = Analog input 3 3 = Analog input 4 4 = Analog input 5 5 = Analog input 6 6 = ProcessDataIn1 (0–100%) 7 = ProcessDataIn2 (0–100%) 8 = ProcessDataIn3 (0–100%) 9 = ProcessDataIn4 (0–100%) 10 = ProcessDataIn5 (0–100%) 11 = ProcessDataIn6 (0–100%) 12 = ProcessDataIn7 (0–100%) 13 = ProcessDataIn8 (0–100%) 14 = Block Out.1 15 = Block Out.2 16 = Block Out.3 17 = Block Out.4 18 = Block Out.5 19 = Block Out.6 20 = Block Out.7 21 = Block Out.8 22 = Block Out.9 23 = Block Out.10
P3.13.9.3	Supervision Unit Selection	0	9	Varies	3	1687	1 = % 2 = mbar

Index	Parameter	Min	Max	Unit	De- fault	ID	Description
							3 = bar 4 = Pa 5 = kPa 6 = PSI 7 = mmHg 8 = Torr 9 = lb/in ²
P3.13.9.4	Supervision Unit Decimals	0	4		2	1688	
P3.13.9.5	Supervision Unit Minimum Value	-99999.99	99999.99	P3.13.9.3	0.00	1689	
P3.13.9.6	Supervision Unit Maximum Value	-99999.99	99999.99	P3.13.9.3	10.0	1690	
P3.13.9.7	Supervision Alarm Level	P3.13.9.5	P3.13.9.6	P3.13.9.3	Varies	1691	
P3.13.9.8	Supervision Fault Level	P3.13.9.5	P3.13.9.7	P3.13.9.3	0.10	1692	
P3.13.9.9	Supervision Fault Delay	0.00	60.00	s	5.00	1693	
P3.13.9.10	PID Setpoint Reduction	0.0	100.0	%	10.0	1694	
P3.13.9.11	Setpoint Red Interpolation Source	0	2		0	1407	0 = Feedback 1 = Input pressure monitor 2 = Disabled
V3.13.9.12	Input Pressure	P3.13.9.5	P3.13.9.6	P3.13.9.3	Varies	1695	This monitoring value shows the actual value of the pump input pressure.

Table 84: Sleep - No Demand Detected

Index	Parameter	Min	Max	Unit	Default	ID	Description
P3.13.10.1	Sleep NoDemand Detection Enable	0	1		0	1649	0 = No 1 = Yes
P3.13.10.2	SNDD Error Hysteresis	0	99999.9	P3.13.1.4	0.5	1658	
P3.13.10.3	SNDD FrequencyHysteresis	0.00	P3.3.1.2	Hz	3.00	1663	
P3.13.10.4	SNDD Supervision Time	0	600	s	120	1668	
P3.13.10.5	SNDD Actual Add	0.00	P3.13.10.2	P3.13.1.4	0.5	1669	

Table 85: Multi-setpoint Parameters

Index	Parameter	Min	Max	Unit	Default	ID	Description
P3.13.12.1	Multi-Setpoint0	P3.13.1.5	P3.13.1.6	P3.13.1.4	0.0	15560	
P3.13.12.2	Multi-Setpoint1	P3.13.1.5	P3.13.1.6	P3.13.1.4	0.0	15561	
P3.13.12.3	Multi-Setpoint2	P3.13.1.5	P3.13.1.6	P3.13.1.4	0.0	15562	
P3.13.12.4	Multi-Setpoint3	P3.13.1.5	P3.13.1.6	P3.13.1.4	0.0	15563	
P3.13.12.5	Multi-Setpoint4	P3.13.1.5	P3.13.1.6	P3.13.1.4	0.0	15564	
P3.13.12.6	Multi-Setpoint5	P3.13.1.5	P3.13.1.6	P3.13.1.4	0.0	15565	
P3.13.12.7	Multi-Setpoint6	P3.13.1.5	P3.13.1.6	P3.13.1.4	0.0	15566	
P3.13.12.8	Multi-Setpoint7	P3.13.1.5	P3.13.1.6	P3.13.1.4	0.0	15567	
P3.13.12.9	Multi-Setpoint8	P3.13.1.5	P3.13.1.6	P3.13.1.4	0.0	15568	
P3.13.12.10	Multi-Setpoint9	P3.13.1.5	P3.13.1.6	P3.13.1.4	0.0	15569	
P3.13.12.11	Multi-Setpoint10	P3.13.1.5	P3.13.1.6	P3.13.1.4	0.0	15570	
P3.13.12.12	Multi-Setpoint11	P3.13.1.5	P3.13.1.6	P3.13.1.4	0.0	15571	
P3.13.12.13	Multi-Setpoint12	P3.13.1.5	P3.13.1.6	P3.13.1.4	0.0	15572	
P3.13.12.14	Multi-Setpoint13	P3.13.1.5	P3.13.1.6	P3.13.1.4	0.0	15573	
P3.13.12.15	Multi-Setpoint14	P3.13.1.5	P3.13.1.6	P3.13.1.4	0.0	15574	
P3.13.12.16	Multi-Setpoint15	P3.13.1.5	P3.13.1.6	P3.13.1.4	0.0	15575	
P3.13.12.17	Multi-SetpointSelection 0				DigINSlot0.1	15576	
P3.13.12.18	Multi-SetpointSelection 1				DigINSlot0.1	15577	

6.14 Group 3.14: External PID Controller

Table 86: Basic Settings for the External PID Controller

Index	Parameter	Min	Max	Unit	Default	ID	Description
P3.14.1.1	Enable External PID	0	1		0	1630	0 = Disabled 1 = Enabled
P3.14.1.2	Start Signal				DigIN Slot0.2	1049	OPEN = PID2 in stop mode CLOSED = PID2 regulating
P3.14.1.3	Output in Stop	0.0	100.0	%	0.0	1100	
P3.14.1.4	PID Gain	0.00	1000.00	%	100.00	1631	See P3.13.1.1
P3.14.1.5	PID Integration Time	0.00	600.00	s	1.00	1632	See P3.13.1.2
P3.14.1.6	PID Derivation Time	0.00	100.00	s	0.00	1633	See P3.13.1.3
P3.14.1.7	Process Unit Selection	0	37		0	1635	See P3.13.1.4

Index	Parameter	Min	Max	Unit	Default	ID	Description
P3.14.1.8	Process Unit Min	Varies	Varies	Varies	0	1664	See P3.13.1.5
P3.14.1.9	Process Unit Max	Varies	Varies	Varies	100	1665	See P3.13.1.6
P3.14.1.10	Process Unit Decimals	0	4		2	1666	See P3.13.1.7
P3.14.1.11	Error Inversion	0	1		0	1636	See P3.13.1.8
P3.14.1.12	Dead Band	Varies	Varies	Varies	0.0	1637	See P3.13.1.9
P3.14.1.13	Dead Band Delay	0.00	320.00	s	0.00	1638	See P3.13.1.10

Table 87: Setpoints of the External PID Controller

Index	Parameter	Min	Max	Unit	Default	ID	Description
P3.14.2.1	Keypad Setpoint 1	P3.14.1.8	P3.14.1.9	Varies	0.00	1640	
P3.14.2.2	Keypad Setpoint 2	P3.14.1.8	P3.14.1.9	Varies	0.00	1641	
P3.14.2.3	Setpoint Ramp Time	0.00	300.00	s	0.00	1642	
P3.14.2.4	Select Setpoint				DigIN Slot0.1	1048	OPEN = Setpoint 1 CLOSED = Setpoint 2
P3.14.2.5	Setpoint Source 1 Selection	0	32		1	1643	0 = Not Used 1 = Keypad Setpoint 1 2 = Keypad Setpoint 2 3 = AI1 4 = AI2 5 = AI3 6 = AI4 7 = AI5 8 = AI6 9 = ProcessDataIn1 10 = ProcessDataIn2 11 = ProcessDataIn3 12 = ProcessDataIn4 13 = ProcessDataIn5 14 = ProcessDataIn6 15 = ProcessDataIn7 16 = ProcessDataIn8 17 = Temperature Input 1 18 = Temperature Input 2 19 = Temperature Input 3 20 = Temperature Input 4 21 = Temperature Input 5 22 = Temperature Input 6 23 = Block Out.1

Index	Parameter	Min	Max	Unit	Default	ID	Description
							24 = Block Out.2 25 = Block Out.3 26 = Block Out.4 27 = Block Out.5 28 = Block Out.6 29 = Block Out.7 30 = Block Out.8 31 = Block Out.9 32 = Block Out.10 If temperature inputs are selected, the values of parameters P3.14.1.8 Process Unit Min and P3.14.1.9 Process Unit Max must be set to correspond to the scale of the temperature measurement board.
P3.14.2.6	Setpoint 1 minimum	-200.00	200.00	%	0.00	1644	
P3.14.2.7	Setpoint 1 maximum	-200.00	200.00	%	100.00	1645	
P3.14.2.8	Setpoint source 2 selection	0	32		2	1646	See P3.14.2.5.
P3.14.2.9	Setpoint 2 minimum	-200.00	200.00	%	0.00	1647	
P3.14.2.10	Setpoint 2 maximum	-200.00	200.00	%	100.00	1648	

Table 88: Feedback of the External PID Controller

Index	Parameter	Min	Max	Unit	Default	ID	Description
P3.14.3.1	Feedback Function	1	9		1	1650	See P3.13.3.1
P3.14.3.2	Feedback Function Gain	-1000.0	1000.0	%	100.0	1651	See P3.13.3.2
P3.14.3.3	Feedback 1 Source Selection	0	30		2	1652	See P3.13.3.3
P3.14.3.4	Feedback 1 Minimum	-200.00	200.00	%	0.00	1653	
P3.14.3.5	Feedback 1 Maximum	-200.00	200.00	%	100.00	1654	
P3.14.3.6	Feedback 2 Source Selection	0	30		0	1655	See P3.13.3.6.
P3.14.3.7	Feedback 2 Minimum	-200.00	200.00	%	0.00	1656	
P3.14.3.8	Feedback 2 Maximum	-200.00	200.00	%	100.00	1657	

Table 89: Process Supervision of the External PID Controller

Index	Parameter	Min	Max	Unit	Default	ID	Description
P3.14.4.1	Enable Supervision	0	1		0	1659	0 = Disabled 1 = Enabled
P3.14.4.2	Upper Limit	Varies	Varies	Varies	0	1660	See P3.13.6.2
P3.14.4.3	Lower Limit	Varies	Varies	Varies	0	1661	See P3.13.6.3
P3.14.4.4	Delay	0	30000	s	0	1662	
P3.14.4.5	Response to External PID Supervision Fault	0	3		2	757	See P3.9.1.2

6.15 Group 3.15: Multi-pump

Table 90: Multi-pump Parameters

Index	Parameter	Min	Max	Unit	Default	ID	Description
P3.15.1	Multi-pump Mode	0	2		0 ⁽¹⁾	1785	0 = Single Drive 1 = Multifollower 2 = Multimaster
P3.15.2	Number of Pumps	1	8		1 ⁽¹⁾	1001	
P3.15.3	Pump ID Number	1	8		0	1500	
P3.15.4	Start and Feedback Signals	0	2		1	1782	0 = Not Connected 1 = Only Start Signal Connected 2 = Both Signals Connected
P3.15.5	Pump Interlocking	0	1		1 ⁽¹⁾	1032	0 = Not used 1 = Enabled
P3.15.6	Autochange	0	2		1 ⁽¹⁾	1027	0 = Disabled 1 = Enabled (interval) 2 = Enabled (weekdays)
P3.15.7	Autochanged Pumps	0	1		1 ⁽¹⁾	1028	0 = Auxiliary pumps 1 = All pumps
P3.15.8	Autochange Interval	0.0	3000.0	h	48.0 ⁽¹⁾	1029	
P3.15.9	Autochange Days	0	127		0	1786	B0 = Sunday B1 = Monday B2 = Tuesday B3 = Wednesday B4 = Thursday B5 = Friday B6 = Saturday
P3.15.10	Autochange: Time ofDay	00:00:00	23:59:59	Time	00:00:00	1787	
P3.15.11	Autochange: Frequency Limit	0.00	P3.3.1.2	Hz	25.00 ⁽¹⁾	1031	

Index	Parameter	Min	Max	Unit	Default	ID	Description
P3.15.12	Autochange: PumpLimit	0	8		1 ⁽¹⁾	1030	
P3.15.13	Bandwidth	0	100	%	10 ⁽¹⁾	1097	Setpoint = 5 bar Bandwidth = 10%.
P3.15.14	Bandwidth Delay	0	3600	s	10 ⁽¹⁾	1098	
P3.15.15	Constant ProductionSpeed	0.0	100.0	%	80.0 ⁽¹⁾	1513	
P3.15.16	Running PumpsLimit	1	P3.15.2		3 ⁽¹⁾	1187	
M3.15.17	Interlock Signals	See Table 91 .					
M3.15.18	Overpressure Supervision	See Table 92 .					
M3.15.19	Pump Running Time	See Table 93 .					
M3.15.20	Advanced Settings	See Table 94 .					

¹ The selection of the application with parameter P1.2 Application gives the default value. See the default values in [11.25 Default Values of Parameters in the Different Applications](#).

Table 91: Interlock Signals

Index	Parameter	Min	Max	Unit	Default	ID	Description
P3.15.17.1	Pump 1 interlock	Varies	Varies		DigINSlot0.1	426	OPEN = Not active CLOSED = Active
P3.15.17.2	Pump 2 interlock	Varies	Varies		DigINSlot0.1	427	OPEN = Not active CLOSED = Active
P3.15.17.3	Pump 3 interlock	Varies	Varies		DigINSlot0.1	428	OPEN = Not active CLOSED = Active
P3.15.17.4	Pump 4 interlock	Varies	Varies		DigINSlot0.1	429	OPEN = Not active CLOSED = Active
P3.15.17.5	Pump 5 interlock	Varies	Varies		DigINSlot0.1	430	OPEN = Not active CLOSED = Active
P3.15.17.6	Pump 6 interlock	Varies	Varies		DigINSlot0.1	486	OPEN = Not active CLOSED = Active
P3.15.17.7	Pump 7 interlock	Varies	Varies		DigINSlot0.1	487	OPEN = Not active CLOSED = Active
P3.15.17.8	Pump 8 interlock	Varies	Varies		DigINSlot0.1	488	OPEN = Not active CLOSED = Active

Table 92: Overpressure Supervision Parameters

Index	Parameter	Min	Max	Unit	Default	ID	Description
P3.15.18.1	Enable Overpressure Supervision	0	1		0	1698	0 = Disabled

Index	Parameter	Min	Max	Unit	Default	ID	Description
							1 = Enabled
P3.15.18.2	Supervision Alarm Level	P3.13.1.5	P3.13.1.6	P3.13.1.4	0.00	1699	

Table 93: Pump Running Time Counter Parameters

Index	Parameter	Min	Max	Unit	Default	ID	Description
P3.15.19.1	Set Run-time Counter	0	1		0	1673	0 = No action 1 = Set the value that is specified by P3.15.19.2 to the run-time counter of the selected pump.
P3.15.19.2	Set Run-time Counter: Value	0	300 000	h	0	1087	
P3.15.19.3	Set Run-time Counter: Pump Selection	0	8		1	1088	0 = All Pumps 1 = Pump (1) 2 = Pump 2 3 = Pump 3 4 = Pump 4 5 = Pump 5 6 = Pump 6 7 = Pump 7 8 = Pump 8
P3.15.19.4	Pump RuntimeAlarm Limit	0	300 000	h	0	1109	0 = Not Used
P3.15.19.5	Pump Run-time FaultLimit	0	300 000	h	0	1110	0 = Not Used

Table 94: Advanced Settings

Index	Parameter	Min	Max	Unit	Default	ID	Description
P3.15.22.1	Staging Frequency	P3.3.1.1	320.0	Hz	320.0	15545	
P3.15.22.2	De-staging Frequency	0.0	P3.3.1.2	Hz	0.00	15546	
P3.15.22.3	Staging Delay	0	3600	s	15588	0	0 = bandwidth delay used
P3.15.22.4	De-staging Delay	0	3600	s	15589	0	0 = bandwidth delay used

6.16 Group 3.16: Maintenance Counters

Table 95: Maintenance Counters

Index	Parameter	Min	Max	Unit	Default	ID	Description
P3.16.1	Counter 1 Mode	0	2		0	1104	0 = Not used 1 = Hours 2 = Revolutions * 1000
P3.16.2	Counter 1 Alarm Limit	0	2147483647	h/kRev	0	1105	0 = Not used

Index	Parameter	Min	Max	Unit	Default	ID	Description
P3.16.3	Counter 1 Fault Limit	0	2147483647	h/kRev	0	1106	0 = Not used
P3.16.4	Counter 1 Reset				0	1107	
P3.16.5	Counter 1 DI Reset				0	490	CLOSED = Reset

6.17 Group 3.17: Fire Mode

Table 96: Fire Mode Parameters

Index	Parameter	Min	Max	Unit	Default	ID	Description
P3.17.1	Fire Mode Password	0	9999		0	1599	1001 = Enabled 1234 = Test mode
P3.17.2	Fire Mode Frequency Source	0	18		0	1617	0 = Fire Mode frequency 1 = Preset speeds 2 = Keypad 3 = Fieldbus 4 = AI1 5 = AI2 6 = AI1 + AI2 7 = PID1 8 = Motor potentiometer 9 = Block Out.1 10 = Block Out.2 11 = Block Out.3 12 = Block Out.4 13 = Block Out.5 14 = Block Out.6 15 = Block Out.7 16 = Block Out.8 17 = Block Out.9 18 = Block Out.10
P3.17.3	Fire Mode Frequency	0.00	P3.3.1.2	Hz	50.00	1598	
P3.17.4	Fire Mode Activation on OPEN				DigIN Slot0.2	1596	OPEN = Fire Mode active CLOSED = No action
P3.17.5	Fire Mode Activation on CLOSE				DigIN Slot0.1	1619	OPEN = No action CLOSED = Fire Mode active
P3.17.6	Fire Mode Reverse				DigIN Slot0.1	1618	OPEN = Forward CLOSED = Reverse DigIN Slot0.1 = Forward DigIN Slot0.2 = Reverse
V3.17.7	Fire Mode Status	0	3			1597	0 = Disabled 1 = Enabled 2 = Activated (Enabled + DI Open)

Index	Parameter	Min	Max	Unit	Default	ID	Description
							3 = Test Mode See 5.4.2 Basic Monitoring Parameters .
V3.17.8	Fire Mode Counter	0	65535			1679	
P3.17.9	Fire Mode Run Indication Current	0	100	%	10	15580	

6.18 Group 3.18: Motor Preheat Parameters

Table 97: Motor Preheat Parameters

Index	Parameter	Min	Max	Unit	Default	ID	Description
P3.18.1	Motor Preheat Function	0	3		0	1225	0 = Not used 1 = Always in stop state 2 = Controlled by DI 3 = Temperature limit, heatsink
P3.18.2	Preheat Temperature Limit	-20	100	°C/F	0	1226	
P3.18.3	Motor Preheat Current	0	0.5*IL	A	Varies	1227	
P3.18.4	Motor Preheat ON	Varies	Varies		DigIN Slot0.1	1044	OPEN = No action CLOSED = Preheat activated in Stop state
P3.18.5	Preheat Motor Temperature	0	6		0	1045	0 = Not Used 1 = Temperature Input 1 2 = Temperature Input 2 3 = Temperature Input 3 4 = Temperature Input 4 5 = Temperature Input 5 6 = Temperature Input 6

6.19 Group 3.19: Drive Customizer

Table 98: Drive Customizer Parameters

Index	Parameter	Min	Max	Unit	Default	ID	Description
P3.19.1	Operation Mode	0	1		1	15001	0 = Execute Program 1 = Programming

6.20 Group 3.21: Pump Control

Table 99: Auto-cleaning Parameters

Index	Parameter	Min	Max	Unit	Default	ID	Description
P3.21.1.1	Cleaning Function	0	3		0	1714	0 = Disabled 1 = Enabled (DIN) 2 = Enabled (current)

Index	Parameter	Min	Max	Unit	Default	ID	Description
							3 = Enabled (weekdays)
P3.21.1.2	Cleaning Activation				DigINSlot0.1	1715	
P3.21.1.3	Cleaning Current Limit	0.0	200.0	%	120.0	1712	
P3.21.1.4	Cleaning CurrentDelay	0.0	300.0	s	60.0	1713	
P3.21.1.5	Cleaning Weekdays	0	127		0	1723	B0 = Sunday B1 = Monday B2 = Tuesday B3 = Wednesday B4 = Thursday B5 = Friday B6 = Saturday
P3.21.1.6	Cleaning Time of Day	00:00:00	23:59:59		00:00:00	1700	
P3.21.1.7	Cleaning Cycles	1	100		5	1716	
P3.21.1.8	Clean Forward Frequency	0.00	50.00	Hz	45.00	1717	
P3.21.1.9	Clean Forward Time	0.00	320.00	s	2.00	1718	
P3.21.1.10	Clean Reverse Frequency	0.00	50.00	Hz	45.00	1719	
P3.21.1.11	Clean Reverse Time	0.00	320.00	s	0.00	1720	
P3.21.1.12	Cleaning Acceleration Time	0.1	300.0	s	0.1	1721	
P3.21.1.13	Cleaning Deceleration Time	0.1	300.0	s	0.1	1722	

Table 100: Jockey Pump Parameters

Index	Parameter	Min	Max	Unit	Default	ID	Description
P3.21.2.1	Jockey Function	0	2		0	1674	0 = Not used 1 = PID sleep 2 = PID sleep (level)
P3.21.2.2	Jockey Start Level	Varies	Varies	Varies	0.00	1675	
P3.21.2.3	Jockey Stop Level	Varies	Varies	Varies	0.00	1676	

Table 101: Priming Pump Parameters

Index	Parameter	Min	Max	Unit	Default	ID	Description
P3.21.3.1	Priming Function	0	1		0	1677	0 = Disabled 1 = Enabled
P3.21.3.2	Priming Time	0.0	320.00		3.0	1678	

Table 102: Anti-blocking Parameters

Index	Parameter	Min	Max	Unit	Default	ID	Description
P3.21.4.1	Anti-blocking Interval	0	96.0	h	0	1696	
P3.21.4.2	Anti-blocking run-time	0	300	s	20	1697	
P3.21.4.3	Anti-blocking frequency	P3.3.1.1	P3.3.1.2	Hz	15.0	1504	

Table 103: Frost Protection Parameters

Index	Parameter	Min	Max	Unit	De- fault	ID	Description
P3.21.5.1	Frost Protec- tion	0	1		0	1704	0 = Disabled 1 = Enabled
P3.21.5.2	Temperature Signal	0	29		6	1705	0 = Temperature Input1 (-50...200° C) 1 = Temperature Input2 (-50...200° C) 2 = Temperature Input3 (-50...200° C) 3 = Temperature Input4 (-50...200° C) 4 = Temperature Input5 (-50...200° C) 5 = Temperature Input6 (-50...200° C) 6 = Analog input 1 7 = Analog input 2 8 = Analog input 3 9 = Analog input 4 10 = Analog input 5 11 = Analog input 6 12 = ProcessDataIn1 (0–100%) 13 = ProcessDataIn2 (0–100%) 14 = ProcessDataIn3 (0–100%) 15 = ProcessDataIn4 (0–100%) 16 = ProcessDataIn5 (0–100%) 17 = ProcessDataIn6 (0–100%) 18 = ProcessDataIn7 (0–100%) 19 = ProcessDataIn8 (0–100%) 20 = Block Out.1 21 = Block Out.2 22 = Block Out.3 23 = Block Out.4 24 = Block Out.5 25 = Block Out.6 26 = Block Out.7 27 = Block Out.8 28 = Block Out.9 29 = Block Out.10
P3.21.5.3	Temperature SignalMini- mum	-50.0 (°C)	P3.21.5.4.4	°C/°F	-50.0 (°C)	1706	
P3.21.5.4	Temperature SignalMaxi- mum	P3.21.5.3	200.0 (°C)	°C/°F	200.0 (°C)	1707	

Index	Parameter	Min	Max	Unit	De- fault	ID	Description
P3.21.5.5	Frost Protec- tion Tempera- ture Limit	P3.21.5.3	P3.21.5.4	°C/°F	5.00 (°C)	1708	
P3.21.5.6	Frost Protec- tion Frequen- cy	0.0	P3.3.1.2	Hz	10.0	1710	
P3.21.5.7	Frost Temper- ature Monitor- ing	Varies	Varies	°C/°F		1711	This monitoring value shows the value of the tem- perature signal that is used for Frost Protection function.

Table 104: Flow Switch Parameters

Index	Parameter	Min	Max	Unit	Default	ID	Description
P3.21.6.1	Flow Switch				DigINSlot0.2	15590	
P3.21.6.2	Flow Switch FaultDelay	0.0	3000.0	s	20.0	15585	
P3.21.6.3	Flow Switch Bypass at Start	0.0	3000.0	s	20.0	15586	
P3.21.6.4	Flow Switch Minimum Frequency	Varies	Varies	Hz	0.0	15587	

6.21 Group 3.23: Advanced Harmonic Filter

Table 105: Advanced Harmonic Filter Parameters

Index	Parameter	Min	Max	Unit	Default	ID	Description
P3.23.1	Cap Disconnect Limit	0	100	%	10	15510	
P3.23.2	Cap Disconnect Hyst	0	100	%	10	15511	
P3.23.3	AHF overtemperature				DigIN Slot0.1	15513	
P3.23.4	AHF Fault Response	0	3		3	15512	0 = No Action 1 = Alarm 2 = Fault 3 = Fault, Coast

6.22 Group 3.24: Condition-based Monitoring

Table 106: Condition-based Monitoring Parameters

Index	Name	Min	Max	Unit	Default	ID	Description
P3.24.1	Condition Based Monitoring Fault Mode	0	2		1	3540	0=No Action 1=Warnings 2=Fault + Warnings
P3.24.2 Baseline Settings							
P3.24.2.1	BaselineRun Start	0	1		0	3501	0=Disabled 1=Enabled
P3.24.2.2	BaselineRun MinFreq	Varies	Varies	Hz	0.00	3502	

Index	Name	Min	Max	Unit	Default	ID	Description
P3.24.2.3	BaselineRun MaxFreq	Varies	Varies	Hz	50.00	3503	
P3.24.2.4	BaselineRun Duration	30	7200	s	120	3504	
P3.24.2.5	Modified Array	0	12		0	3505	0=Freq Points 1=Cur Max Steady 2=Cur Min Steady 3=Cur Mean Steady 4=Cur Std Steady 5=Vibr Max Ramp 6=Vibr Min Ramp 7=Vibr Mean Ramp 8=Vibr Std Ramp 9=Load Max Steady 10=Load Min Steady 11=Load Mean Steady 12=Load Std Steady
P3.24.2.6	Modified Point	0	9		0	3506	
P3.24.2.7	Modified Value	-300.00	320.00	various	0.00	3507	
B3.24.2.8	Modified Activation	0	1		0	3508	0=Disabled 1=Enabled
P3.24.2.9	Baseline Data Selector	0	12		0	3509	0=Freq Points 1=Cur Max Steady 2=Cur Min Steady 3=Cur Mean Steady 4=Cur Std Steady 5=Vibr Max Ramp 6=Vibr Min Ramp 7=Vibr Mean Ramp 8=Vibr Std Ramp 9=Load Max Steady 10=Load Min Steady 11=Load Mean Steady 12=Load Std Steady
P3.24.3 Stator Winding							
P3.24.3.1	Line Freq	0.00	100.00	Hz	50.00	1913	
P3.24.3.2	Line Freq Hyst	0.00	10.00	Hz	1.00	1914	
P3.24.3.3 Current Unbalance							
P3.24.3.3.1 Threshold Value							
P3.24.3.3.1.1	Mean Factor	-10.0	10.00		1.0	3511	
P3.24.3.3.1.2	Min Factor	-10.0	10.00		0.0	3512	
P3.24.3.3.1.3	Max Factor	-10.0	10.00		0.0	3513	
P3.24.3.3.1.4	Std Factor	-10.0	10.00		0.0	3514	

Index	Name	Min	Max	Unit	Default	ID	Description
P3.24.3.3.1.5	Interpolation Type	0	1		1	3515	0=Constant 1=Linear
P3.24.3.3.2 Limits							
P3.24.3.3.2.1	Warning S1 Mode	0	2		0	3516	0=Abs. Value 1=Baseline Offset 2=Baseline Factor
P3.24.3.3.2.2	Warning S1 High	0.00	100.00	%	0.00	3517	
P3.24.3.3.2.3	Warning S1 Delay	0	3600	s	0	3518	
P3.24.3.3.2.4	Warning S2 Mode	0	2		0	3519	0=Abs. Value 1=Baseline Offset 2=Baseline Factor
P3.24.3.3.2.5	Warning S2 High	0.00	100.00	%	0.00	3520	
P3.24.3.3.2.6	Warning S2 Delay	0	3600	s	0	3521	
P3.24.3.3.2.7	Alarm/Fault Mode	0	2		0	3522	0=Abs. Value 1=Baseline Offset 2=Baseline Factor
P3.24.3.3.2.8	Alarm/Fault High	0.00	100.00	%	0.00	3523	
P3.24.3.3.2.9	Alarm/Fault Delay	0	3600	s	0	3524	
P3.24.3.3.3 Counters							
P3.24.3.3.3.1	Warning S1 Counter	0.0	360.0	s	0.0	3541	
P3.24.3.3.3.2	Warning S2 Counter	0.0	360.0	s	0.0	3542	
P3.24.3.3.3.3	Alarm/Fault Counter	0.0	360.0	s	0.0	3543	
P3.24.3.3.3.4	Stop Counter Delay	0.0	320.0	s	0.0	3549	
P3.24.4 Vibration							
P3.24.4.1	Vibration Input	0	4		0	3587	0=Not Used 1=AI1 2=AI2 3=AI3 4=AI4
P3.24.4.2 Threshold Value							
P3.24.4.2.1	Mean Factor	-10.0	10.0.0		0.0	3550	
P3.24.4.2.2	Min Factor	-10.0	10.0.0		0.0	3551	
P3.24.4.2.3	Max Factor	-10.0	10.0.0		1.0	3552	
P3.24.4.2.4	Std Factor	-10.0	10.0.0		0.0	3553	
P3.24.4.2.5	Interpolation Type	0	1		0	3554	0=Constant

Index	Name	Min	Max	Unit	Default	ID	Description
							1=Linear
P3.24.4.3 Limits							
P3.24.4.3.1	Warning S1 Mode	0	2		0	3555	0=Abs. Value 1=Baseline Offset 2=Baseline Factor
P3.24.4.3.2	Warning S1 High	0.00	100.00	%	0.00	3556	
P3.24.4.3.3	Warning S1 Delay	0	3600	s	0	3557	
P3.24.4.3.4	Warning S2 Mode	0	2		0	3558	0=Abs. Value 1=Baseline Offset 2=Baseline Factor
P3.24.4.3.5	Warning S2 High	0.00	100.00	%	0.00	3559	
P3.24.4.3.6	Warning S2 Delay	0	3600	s	0	3560	
P3.24.4.3.7	Alarm/Fault Mode	0	2		0	3561	0=Abs. Value 1=Baseline Offset 2=Baseline Factor
P3.24.4.3.8	Alarm/Fault High	0.00	100.00	%	0.00	3562	
P3.24.4.3.9	Alarm/Fault Delay	0	3600	s	0	3563	
P3.24.4.4 Counters							
P3.24.4.4.1	Warning S1 Counter	0.0	360.0	s	0.0	3564	
P3.24.4.4.2	Warning S2 Counter	0.0	360.0	s	0.0	3565	
P3.24.4.4.3	Alarm/Fault Counter	0.0	360.0	s	0.0	3566	
P3.24.4.4.4	Stop Counter Delay	0.0	320.0	s	0.0	3549	
P3.24.5 Load							
P3.24.5.1 Threshold Value							
P3.24.5.1.1	Mean Factor	-10.0	10.0.0		1.0	3567	
P3.24.5.1.2	Min Factor	-10.0	10.0.0		0.0	3568	
P3.24.5.1.3	Max Factor	-10.0	10.0.0		0.0	3569	
P3.24.5.1.4	Std Factor	-10.0	10.0.0		0.0	3570	
P3.24.5.1.5	Interpolation Type	0	1		1	3571	0=Constant 1=Linear
P3.24.5.2 Limits							
P3.24.5.2.1	Warning S1 Mode	0	2		0	3572	0=Abs. Value 1=Baseline Offset 2=Baseline Factor
P3.24.5.2.2	Warning S1 Low	-300.0	300.0	%	0.00	3584	

Index	Name	Min	Max	Unit	Default	ID	Description
P3.24.5.2.3	Warning S1 High	-300.0	300.0	%	0.00	3573	
P3.24.5.2.4	Warning S1 Delay	0	3600	s	0	3574	
P3.24.5.2.5	Warning S2 Mode	0	2		0	3575	0=Abs. Value 1=Baseline Offset 2=Baseline Factor
P3.24.5.2.6	Warning S2 Low	-300.0	300.0	%	0.00	3585	
P3.24.5.2.7	Warning S2 High	-300.0	300.0	%	0.00	3576	
P3.24.5.2.8	Warning S2 Delay	0	3600	s	0	3577	
P3.24.5.2.9	Alarm/Fault Mode	0	2		0	3578	0=Abs. Value 1=Baseline Offset 2=Baseline Factor
P3.24.5.2.10	Alarm/Fault Low	-300.0	300.0	%	0.00	3586	
P3.24.5.2.11	Alarm/Fault High	-300.0	300.0	%	0.00	3579	
P3.24.5.2.10	Alarm/Fault Delay	0	3600	s	0	3580	
P3.24.5.3 Counters							
P3.24.5.3.1	Warning S1 Counter	0.0	360.0	s	0.0	3581	
P3.24.5.3.2	Warning S2 Counter	0.0	360.0	s	0.0	3582	
P3.24.5.3.3	Alarm/Fault Counter	0.0	360.0	s	0.0	3583	
P3.24.5.3.4	Stop Counter Delay	0.0	320.0	s	0.0	3549	

7 Diagnostics Menu

7.1 Faults

7.1.1 Uses of the Active Faults Submenu

When there is a fault or many faults, the display shows the name of the fault and blinks. Push [OK] to go back to the *Diagnostics* menu. The submenu *Active faults* shows the number of faults. To see the fault-time data, select a fault and push [OK].

The *Active faults* submenu can keep storage of maximum 10 faults. The submenu shows the faults in the sequence in which they occurred.

7.1.2 Reset Faults

When the drive shows a fault and stops, examine the cause of fault, and reset the fault. The fault stays active until it is reset.

There are 2 procedures to reset a fault in the local control place: with the [BACK/RESET] button and with a parameter. It is also possible to reset faults by using I/O, a fieldbus, or a PC tool.

NOTICE

Before resetting the fault, remove the external control signal to prevent restarting the drive accidentally.

7.1.2.1 Resetting Faults with the [BACK/RESET] Button

Procedure

1. Push the [BACK/RESET] button on the keypad of the control panel for 2 seconds.

7.1.2.2 Resetting Faults with a Parameter on the Graphical Display

Faults can be reset with the parameter *Reset Faults*.

Procedure

1. Go to the *Diagnostics Menu*.
2. Go to the submenu *Reset faults*.
3. Select the parameter *Reset Faults*.



7.1.2.3 Resetting Faults with a Parameter on the Text Display

Faults can be reset with the parameter *Reset Faults*.

Procedure

1. Go to the *Diagnostics menu*.
2. Use the arrow buttons Up and Down to find the parameter *Reset Faults*.

3. Select the value Yes and push [OK].

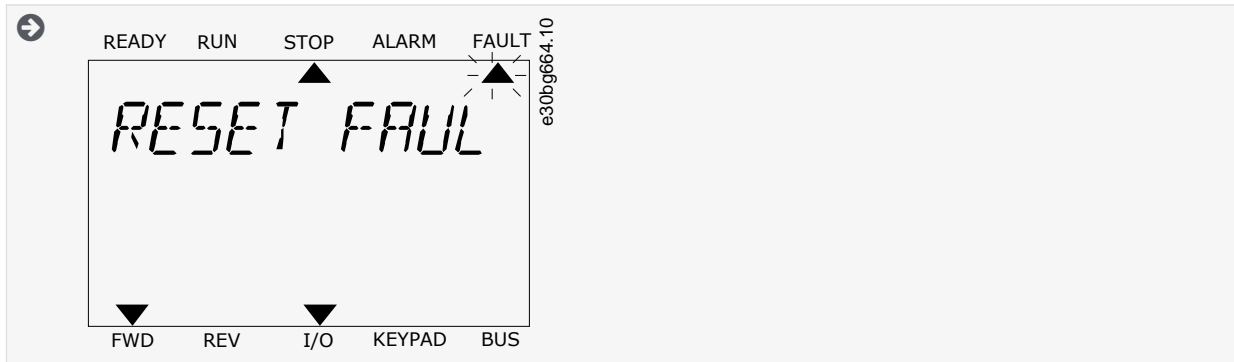

7.1.3 Uses of the Fault History

The Fault history shows more data on the faults. There is a maximum number of 40 faults in the Fault history.

7.1.3.1 Examining the Fault History on the Graphical Display

Procedure

1. To see more data on a fault, go to *Fault history*.

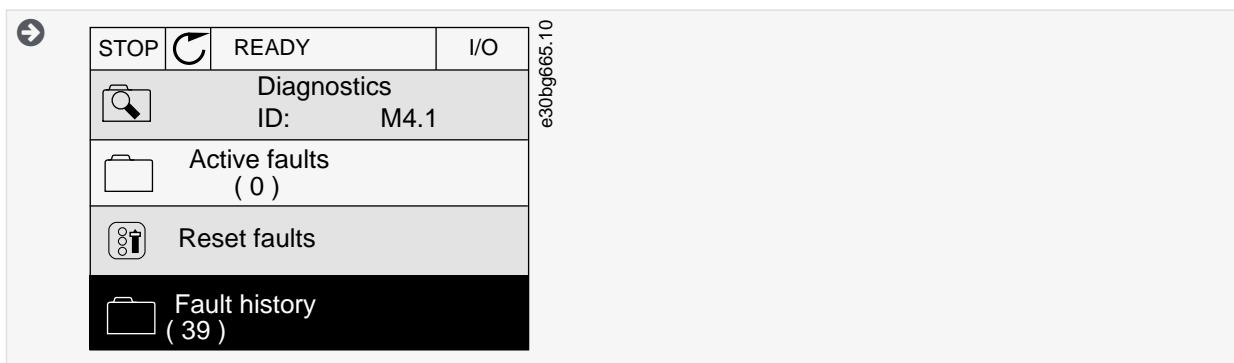

2. To examine the data of a fault, push the Arrow button Right.
3. Examine the data in a list.

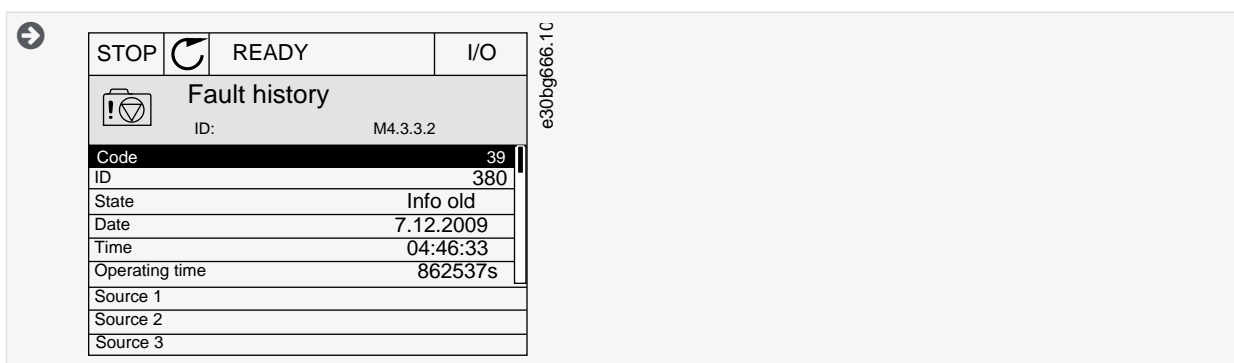

7.1.3.2 Examining the Fault History on the Text Display

Procedure

1. Push [OK] to go to *Fault history*.

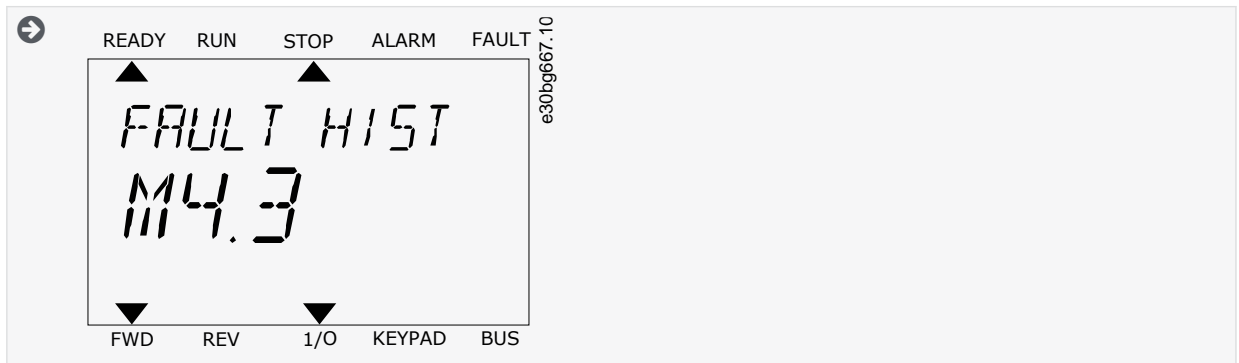

2. To examine the data of a fault, push [OK] again.
3. Use the arrow button down to examine all the data.

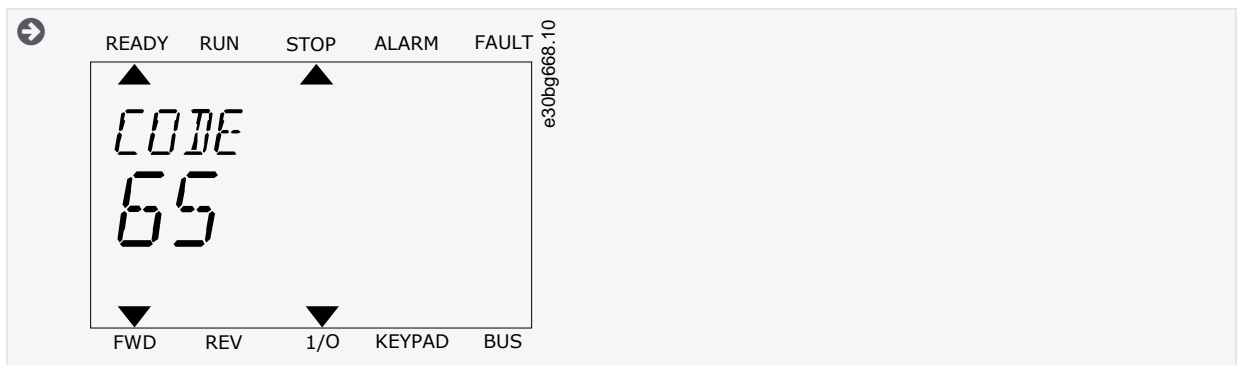

7.2 Counters

7.2.1 Using the Counters

It is possible to monitor all the counter values from the PC, control panel, or fieldbus.

In the PC or the control panel, the counter values can be monitored in the *Diagnostics* menu. In fieldbus, see [12.4 Total and Trip Counters](#).

7.2.2 Total Counters

Table 107: The Total Counter Parameters in the *Diagnostics* Menu

Index	Parameter	Min	Max	Unit	De- fault	ID	Description
V4.4.1	Energy Counter			Varies		2291	The quantity of energy taken from the supply network. The counter cannot be reset. In the text display: the highest energy unit that the display shows is MW. If the counted energy becomes more than 999.9 MW, no unit shows on the display.
V4.4.3	Operating Time (graphical keypad)			a d hh:min		2298	The operating time of the control unit.
V4.4.4	Operating Time (text keypad)			a			The operating time of the control unit in total years.
V4.4.5	Operating Time (text keypad)			d			The operating time of the control unit in total days.

Index	Parameter	Min	Max	Unit	De- fault	ID	Description
V4.4.6	Operating Time (text keypad)			hh:min:ss			The operating time of the control unit in hours, minutes, and seconds.
V4.4.7	Run Time (graphical keypad)			a d hh:min		2293	The motor run time.
V4.4.8	Run Time (text keypad)			a			The motor run time in total years.
V4.4.9	Run Time (text keypad)			d			The motor run time in total days.
V4.4.10	Run Time (text keypad)			hh:min:ss			The motor run time in hours, minutes, and seconds.
V4.4.11	Power On Time (graphical keypad)			a d hh:min		2294	The quantity of time that the power unit has been powered on. The counter cannot be reset.
V4.4.12	Power On Time (text keypad)			a			The power on time in total years.
V4.4.13	Power On Time (text keypad)			d			The power on time in total days.
V4.4.14	Power On Time (text keypad)			hh:min:ss			The power on time in hours, minutes, and seconds.
V4.4.15	Start Command Counter					2295	The number of times that the power unit has been started.

7.2.3 Trip Counters

Table 108: The Trip Counter Parameters in the *Diagnostics* Menu

Index	Parameter	Min	Max	Unit	De- fault	ID	Description
P4.5.1	Energy Trip Counter			Varies		2296	This counter can be reset. In the text display: the highest energy unit that the display shows is MW. If the counted energy becomes more than 999.9 MW, no unit shows on the display. Resetting the counter: <ul style="list-style-type: none"> In the text display: Push the [OK] button for 4 s. In the graphical display: Push [OK]. A Reset counter page shows. Push [OK] again.
P4.5.3	Operating Time (graphical keypad)			a d hh:min		2299	This counter can be reset. See instructions in P4.5.1.
P4.5.4	Operating Time (text keypad)			a			The operating time in total years.
P4.5.5	Operating Time (text keypad)			d			The operating time in total days.
P4.5.6	Operating Time (text keypad)			hh:min:ss			The operating time in hours, minutes, and seconds.

7.3 Software Info

Table 109: The Software Info Parameters in the *Diagnostics Menu*

Index	Parameter	Min	Max	Unit	De- fault	ID	Description
V4.6.1	Software Package (graphical keypad)					2524	The code for the software identification
V4.6.2	Software Package ID (text keypad)						The code for the software identification
V4.6.3	Software Package Version (text keypad)						The code for the software identification
V4.6.4	System Load	0	100	%		2300	The load on the control unit CPU
V4.6.5	Application Name (graphical keypad)					2525	The name of the application
V4.6.6	Application ID					837	The code of the application
V4.6.7	Application Version					838	
V4.6.8	Language Selections						Selected language package in software loading
V4.6.9	Keypad Software Version						

7.4 Drive Info

Table 110: The Drive Info Parameters in the *Diagnostics Menu*

Index	Parameter	Min	Max	Unit	Default	ID	Description
V4.7.1	Power Size						

7.5 Unit Status

Table 111: The Unit Status Parameters in the *Diagnostics Menu*

Index	Parameter	Min	Max	Unit	Default	ID	Description
V4.8.1	Control Unit ID					2540	Status of the control unit
V4.8.2	Power Unit ID					2541	Status of the power unit

8 I/O and Hardware Menu

8.1 Basic I/O

Table 112: The Basic I/O Parameters in the I/O and Hardware Menu

Index	Parameter	Min	Max	Unit	Default	ID	Description
V5.1.1	Digital Input 1	0	1		0	2502	Status of the digital input signal
V5.1.2	Digital Input 2	0	1		0	2503	Status of the digital input signal
V5.1.3	Digital Input 3	0	1		0	2504	Status of the digital input signal
V5.1.4	Digital Input 4	0	1		0	2505	Status of the digital input signal
V5.1.5	Digital Input 5	0	1		0	2506	Status of the digital input signal
V5.1.6	Digital Input 6	0	1		0	2507	Status of the digital input signal
V5.1.7	Analog Input 1 Mode	1	3		3	2508	Shows the mode that is set for the analog input signal. The selection is made with a DIP switch on the control board. 1 = 0...20mA 3 = 0...10V
V5.1.8	Analog Input 1	0	100	%	0.00	2509	Status of the analog input signal
V5.1.9	Analog Input 2 Mode	1	3		3	2510	Shows the mode that is set for the analog input signal. The selection is made with a DIP switch on the control board. 1 = 0...20mA 3 = 0...10V
V5.1.10	Analog Input 2	0	100	%	0.00	2511	Status of the analog input signal
V5.1.11	Analog Output 1 Mode	1	3		1	2512	Shows the mode that is set for the analog input signal. The selection is made with a DIP switch on the control board. 1 = 0...20mA 3 = 0...10V
V5.1.12	Analog Output 1	0	100	%	0.00	2513	Status of the analog output signal
V5.1.13	Relay Output 1	0	1		0	2514	Status of the relay output signal
V5.1.14	Relay Output 2	0	1		0	2515	Status of the relay output signal
V5.1.15	Relay Output 3	0	1		0	2516	Status of the relay output signal

8.2 Option Board Slots

The parameters in this menu are different for all the option boards. The parameters of the installed option board is shown. If there is no option board in the slots C, D or E, no parameters are shown. See more about the location of the slots in chapter [11.7.1.1 General Information on the Programming](#).

When an option board is removed, the fault code 39 and the fault name *Device removed* show on the display.

Table 113: Option Board Related Parameters

Menu	Function	Description
Slot C	Settings	The settings that are related to the option board.
	Monitoring	Monitor the data that is related to the option board.
Slot D	Settings	The settings that are related to the option board.
	Monitoring	Monitor the data that is related to the option board.
Slot E	Settings	The settings that are related to the option board.
	Monitoring	Monitor the data that is related to the option board.

8.3 Real-time Clock

Table 114: The Real-time Clock Parameters in the I/O and Hardware Menu

Index	Parameter	Min	Max	Unit	De- fault	ID	Description
V5.5.1	Battery State	1	3			2205	Status of the battery. 1 = Not installed 2 = Installed 3 = Replace the battery
P5.5.2	Time			hh:mm:ss		2201	The current time of the day
P5.5.3	Date			dd.mm.		2202	The current date
P5.5.4	Year			yyyy		2203	The current year
P5.5.5	Daylight Saving	1	4			2204	The daylight saving rule 1 = Off 2 = EU: starts on the last Sunday in March, ends on the last Sunday in October 3 = US: starts on the 2nd Sunday in March, ends on the 1st Sunday in November 4 = Russia (permanent)

8.4 Simple Network Time Protocol (SNTP)

The simple network time protocol (SNTP) allows devices connected to a TCP/IP network receive precise time information from designated time servers. The time information can be received either by the client device polling the time servers or the time servers broadcasting the time.

Table 115: SNTP parameters

Index	Parameter	Min	Max	Unit	Default	ID	Description
V5.5.7.1.1	SNTP Mode					3162	
V5.5.7.1.2	Server 1 IP					3163	
V5.5.7.1.3	Server 2 IP					3164	
V5.5.7.1.4	SNTP Port					3165	
V5.5.7.1.5	Time Interval					3166	

8.5 Power Unit Settings

In this menu, the settings of the fan, the brake chopper, the sine filter, and the harmonic filter can be changed.

The fan operates in the optimized or the always on mode. In the optimized mode, the internal logic of the drive receives data about the temperature and controls the fan speed. After the drive goes in the Ready state, the fan stops in 5 minutes. In the always on mode, the fan operates in full speed, and does not stop.

The sine filter keeps the overmodulation depth in limits and does not let the thermal management functions decrease the switching frequency.

The harmonic filter can be enabled to avoid possible resonances in the DC link of the AC drive.

Table 116: Power Unit Settings

Index	Parameter	Min	Max	Unit	Default	ID	Description
P5.6.1.1	Fan Control Mode	0	1		1	2377	0 = Always on 1 = Optimized
V5.6.1.5	Fan Lifetime ID					849	Lifetime of the fan of the drive
P5.6.1.6	Fan lifetime alarm limit	0	200000	h	50000	824	Alarm limit of the fan lifetime
B5.6.1.7	Fan lifetime reset ID					823	Reset the fan lifetime counter with this button.
P5.6.2.1	Brake Chopper Mode	0	3		0	2526	0 = Disabled 1 = Enabled (Run) 2 = Enabled (Run & Stop) 3 = Enabled (Run, no testing)
P5.6.3.1	Max Switching Freq	1.5	Varies	kHz		2620	
P5.6.5.1	Sine Filter	0	1		0	2527	0 = Disabled 1 = Enabled
P5.6.6.1	Harmonic Filter	0	1		0	2497	0 = Disabled 1 = Enabled
P5.6.9.1	Fast supply rise	0	1		0	2665	Use this parameter to enable fast rise in estimated supply voltage. 0 = Disabled 1 = Enabled

8.6 Keypad

Table 117: The Keypad Parameters in the I/O and Hardware Menu

Index	Parameter	Min	Max	Unit	De- fault	ID	Description
P5.7.1	Timeout Time	0	60	min	0	804	The time after which the display goes back to the page that is set with parameter P5.7.2. 0 = Not used
P5.7.2	Default Page	0	4		0	2318	The page that the display shows when the drive is powered up, or when the time that is set with P5.7.1 is expired. If the value is set to 0, the display shows the last page that it showed. 0 = None 1 = A menu index 2 = Main menu 3 = Control page

Index	Parameter	Min	Max	Unit	De- fault	ID	Description
							4 = Multimonitor
P5.7.3	Menu Index					2499	Set a page to be the menu index. (The selection 1 in P5.7.2.)
P5.7.4	Contrast ⁽¹⁾	30	70	%	50	830	Set the contrast of the display.
P5.7.5	Backlight Time	0	60	min	5	818	Set the time after which the backlight of the display turns off. If the value is set to 0, the backlight is always on.

¹ Only available with the graphical keypad.

8.7 Fieldbus

In the I/O and Hardware menu, there are the parameters that are related to fieldbus boards. Find the instructions on how to use these parameters in the related fieldbus manual.

Table 118: Fieldbus Menu Structure

Submenu level 1	Submenu level 2	Submenu level 3	Submenu level 4
RS-485	Common settings	Protocol	Modbus RTU
			N2
			BACnet MSTP
RS-485	Modbus RTU	Parameters	Slave address
			Baud rate
			Parity type
			Stop bits
			Communication timeout
			Operate mode
		Monitoring	Fieldbus protocol status
			Communication status
			Illegal functions
			Illegal data addresses
			Illegal data values
			Slave device busy
			Memory parity error
			Slave device failure
			Last fault response
			Control Word
			Status Word
RS-485	N2	Parameters	Slave address

Submenu level 1	Submenu level 2	Submenu level 3	Submenu level 4
			Communication timeout
		Monitoring	Fieldbus protocol status
			Communication status
			Invalid data
			Invalid commands
			Command not accepted
			Control word
			Status word
RS-485	BACnet MSTP	Parameters	Baud rate
			Autobauding
			MAC address
			Instance number
			Communication timeout
		Monitoring	Fieldbus protocol status
			Communication status
			Actual instance number
			Fault code
			Control word
			Status word
Ethernet	Common settings	IP address mode	
		Duplicate IP Detection	
		Speed/Duplex	
		Ethernet Fieldbus 1	
		Ethernet Fieldbus 2	
		IP Port Filter	
		Drive PC Tool	
		Fixed IP	IP address
			Subnet mask
			Default gateway
		IP address	
		Subnet mask	
		Default gateway	

Submenu level 1	Submenu level 2	Submenu level 3	Submenu level 4
		MAC address	
Ethernet	Modbus TCP ⁽¹⁾		
Ethernet	BACnet IP ⁽²⁾		
Ethernet	EtherNet/IP ⁽³⁾		
Ethernet	PROFINET I/O ⁽⁴⁾		

¹ For details, see VACON 100 Modbus User Manual.

² For details, see VACON 100 BACnet Installation Manual.

³ For details, see VACON 100 EtherNet IP Installation Manual.

⁴ For details, see VACON 100 Profinet IO Installation Manual.

8.8 Fieldbus General

Enabling Ethernet Fieldbus Protocol

Needed internal Ethernet based fieldbus protocols can be enabled with parameters “Ethernet Fieldbus 1”, 5.9.1.4 (ID 2622) and “Ethernet Fieldbus 2”, 5.9.1.5 (ID 2623). The parameters are included since VACON® 100 INDUSTRIAL V030 and VACON® 100 FLOW V022 firmware.

Both parameters contain the same list with “PROFINET I/O, EtherNet/IP, BACnet/IP and Modbus TCP” protocols. PROFINET I/O and EtherNet/IP are visible only if included in drive configuration. By default Modbus TCP is enabled, but if not used, it is recommended to turn it off.

If the same fieldbus is selected to both parameters, the fieldbus protocol is still activated only once. Protocol specific menu tree becomes visible only after enabling it from these parameters. When using VACON® Live, to see protocol specific menus, the “5.9 Ethernet” menu tree must be reloaded after enabling the protocols.

When restoring parameters from older firmware version, drive checks on start-up which protocols were enabled in old firmware and sets up these new parameters accordingly. After having restored parameters, restart the drive. If more than two Ethernet fieldbuses were activated in old firmware, new firmware allows it. In this case, these two new parameters show “None”, but when the values are changed, all Ethernet fieldbuses are stopped, and only the enabled ones are started.

Table 119: Fieldbus Common Settings

Index	Parameter	Min	Max	Unit	Default	ID	Description
P5.9.1.4	Ethernet Fieldbus 1	None	BACnet/IP ⁽¹⁾		None	2622	2 Ethernet-based internal fieldbuses can be enabled at a time. Select fieldbus from the list.
P5.9.1.5	Ethernet Fieldbus 2	None	BACnet/IP ⁽¹⁾		Modbus TCP	2623	
P5.9.1.6	IP Port Filter	0	65535		0	2641	Use this parameter to block IP ports/protocols.
P5.9.1.7	Drive PC Tool	Configuration	Disabled		Configuration	2642	Use this parameter to block VACON® PC Tools over Ethernet, for example, VACON® Live.

¹ Depends on fieldbuses included in drive configuration

Table 120: Fieldbus General

Index	Parameter	Min	Max	Unit	Default	ID	Description
P5.13.1	Controlling Fieldbus					2539	
V5.13.2	Controlling Fieldbus					2610	

8.9 STO

Table 121: STO Parameters

Index	Parameter	Min	Max	Unit	Default	ID	Description
V5.12.1.1	Channel 1	0	1		0		See VACON® 100 OPTBJ STO Option Board User Manual.
V5.12.1.2	Channel 2	0	1		0		
P5.12.2.1	Fan Stop on STO	Disabled	Enabled		Disabled	2616	

N O T I C E

These parameters are only visible when an STO option board is connected.

8.10 Fieldbus Redundancy

supports the usage of two fieldbus connections. The drive accepts control data only from the primary fieldbus. If the primary fieldbus connection fails, the control can be automatically switched to a secondary fieldbus using the fieldbus redundancy control. built-in fieldbus protocols support fieldbus redundancy control. The only exception is RS485 N2, which does not support fieldbus redundancy. Recent firmware versions of fieldbus option boards also support fieldbus redundancy.

When *switch on failing* mode is selected, and the current fieldbus connection detects missing communication from the controller, the switchover command is given to change to the other fieldbus connection. When *switch on faulted* mode is selected, and the current fieldbus connection gets a timeout, the switchover command is given to change to the other fieldbus connection.

The switchback functionality forces a change back to the primary fieldbus connection when it is in operational state and when the given time delay has elapsed. If the switchback functionality is deactivated, the switchover between the fieldbus connections is only performed when the currently controlling fieldbus begins to fail or becomes faulted.

The currently controlling fieldbus protocol can be checked from the monitoring value *V5.13.2 Controlling Fieldbus* (ID 2610).

Table 122: Fieldbus Redundancy

Index	Parameter	Min	Max	Unit	Default	ID	Description
P5.13.3.1	Redundancy Mode	0	2		0	2606	0 = Disabled 1 = Switch on failing 2 = Switch on faulted
P5.13.3.2	Primary Fieldbus Connection				0	2607	
P5.13.3.3	Secondary Fieldbus Connection				0	2608	
P5.13.3.4	Switchover Timeout	0	65535	ms	0	2609	
P5.13.3.5	Switchback Timeout	0	65535	s	10	2612	
V5.13.3.6	Switchover Counter					2611	

9 User Settings, Favourites, and User Level Menus

9.1 User Settings

9.1.1 User Settings Parameters

Table 123: General Settings in the User Settings Menu

Index	Parameter	Min	Max	Unit	Default	ID	Description
P6.1	Language selection	Varies	Varies		Varies	802	The selection is different in all the language packages.
P6.2	Application Selection					801	Select the application.
M6.5	Parameter back-up						See 9.1.2 Parameter Back-up Parameters .
M6.6	Parameter compare						See 9.1.3 Parameter Compare Parameters .
P6.7	Drive name					2528	Use VACON® Live PC tool to give a name to the drive if necessary.
M6.8	Licenses						See 9.1.4 License Parameters .

9.1.2 Parameter Back-up Parameters

Table 124: The Parameter Back-up Parameters in the User Settings menu

Index	Parameter	Min	Max	Unit	De- fault	ID	Description
B6.5.1	Restore Factory Defaults					831	Restores the default parameter values and starts the Startup wizard.
P6.5.2	Save to Keypad ⁽¹⁾	0	1		0	2478	Saves the parameter values to the control panel, for example to copy them to another drive. 0 = No 1 = Yes
P6.5.3	Restore from Keypad ⁽¹⁾					2488	Loads the parameter values from the control panel to the drive.
B6.5.4	Save to Set 1					2489	Keeps a customized parameter set (that is, all the parameters included in the application).
B6.5.5	Restore from Set 1					2490	Loads the customized parameter set to the drive.
B6.5.6	Save to Set 2					2491	Keeps another customized parameter set (that is, all the parameters included in the application).
B6.5.7	Restore from Set 2					2492	Loads the customized parameter set 2 to the drive.

¹ Only available with the graphical display.

9.1.3 Parameter Compare Parameters

Table 125: Parameter Compare Parameters in the User Settings Menu

Index	Parameter	Min	Max	Unit	Default	ID	Description
B6.6.1	Active set - Set 1					2493	
B6.6.2	Active set - Set 2					2494	
B6.6.3	Active set - Defaults					2495	
B6.6.4	Active set - Keypad Set					2496	

9.1.4 License Parameters

Table 126: License Parameters in the User Settings Menu

Index	Parameter	Min	Max	Unit	Default	ID	Description
P6.8.1	Insert License						Insert a drive-specific license to enable new features or remove added features.

9.2 Favourites

9.2.1 Using the Favourites Menu

This menu is available on the control panel with the graphical display, but not on the control panel with the text display. This menu is not available in the VACON® Live tool.

If the same items are used frequently, they can be added into *Favourites*. Collect a set of parameters or monitoring signals from all the control panel menus. It is not necessary to find them in the menu structure one by one. As an alternative, add them into the *Favourites* folder where it is easy to find them.

9.2.2 Adding an Item to the Favourites

It is possible to add frequently used items into *Favourites* where they are easily accessible.

Procedure

1. Find the item to be added to *Favourites*. Push the [OK] button.
2. Select *Add to favourites* and push the [OK] button.

The steps are now completed.

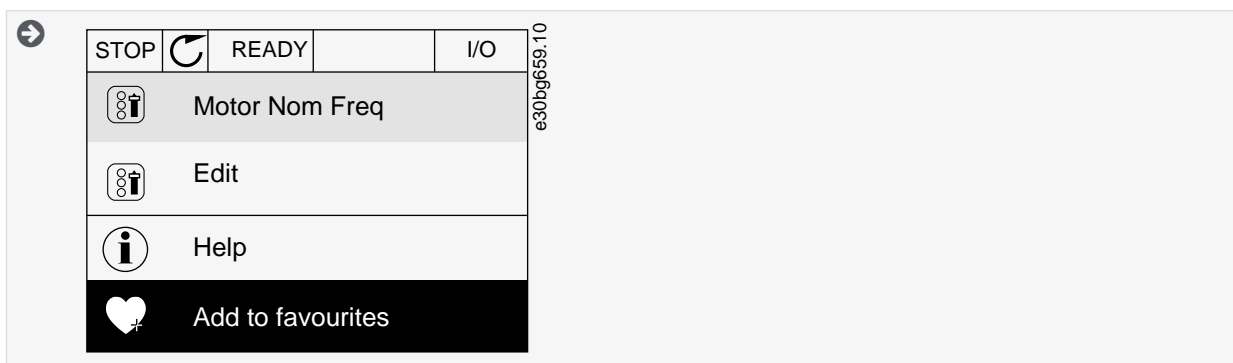

3. To continue, read the instructions on the display.

9.2.3 Removing an Item from the Favourites

Procedure

1. Go to the *Favourites*.
2. Find the item to be removed. Push the [OK] button.

3. Select *Rem from favourites*.

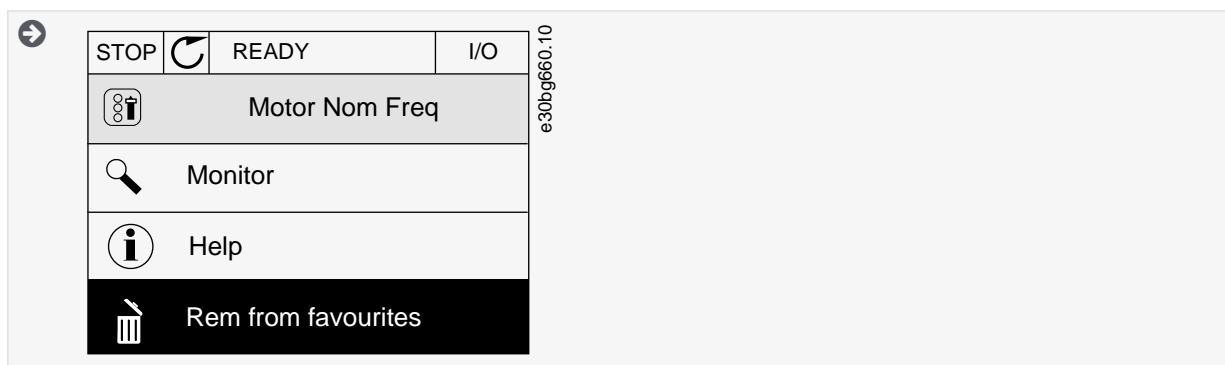

4. To remove the item, push the [OK] button again.

9.3 User Levels

9.3.1 Using the User Levels Menu

Use the *User level* parameters to keep the personnel who are not approved from changing the parameters. Also accidental changes in the parameters can be prevented.

When a user level is selected, the user cannot see all the parameters on the display of the control panel.

9.3.2 The User Level Parameters

Table 127: The User Level Parameters

Index	Parameter	Min	Max	Unit	Default	ID	Description
P8.1	User Level	1	3		1	1194	1 = Normal. All the menus are visible in the main menu. 2 = Monitoring. Only the monitoring and user level menus are visible in the main menu. 3 = Favourites. Only the favourites and user level menus are visible in the main menu. 4 = Monitoring & Favourites. Monitoring, favourites and user level menus are visible in the main menu.
P8.2	Access Code	0	99999		0	2362	If the value is set to be other than 0 before going to Monitoring from, for example, Normal, the access code has to be given when going back to Normal. This prevents personnel who are not approved from making changes in the parameters on the control panel. NOTE! Do not lose the access code. If the access code is lost, contact your nearest service center or partner.

9.3.3 Changing the Access Code of the User Levels

Procedure

1. Go to the *User levels*.
2. Go to the item *Access code* and push the arrow button Right.

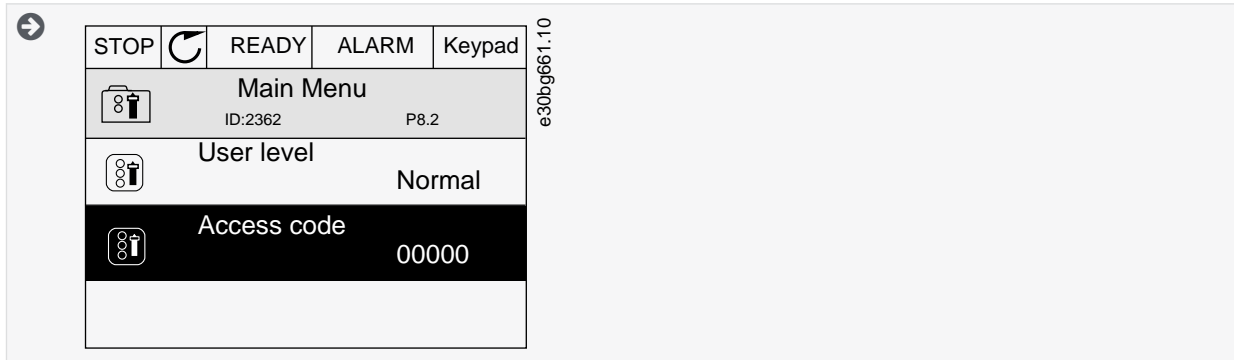

3. To change the digits of the *Access code*, use all the arrow buttons.

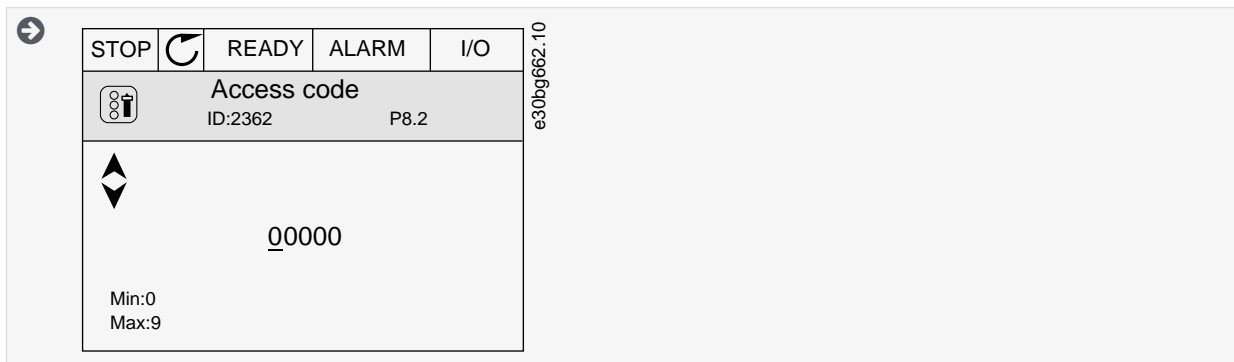

4. Accept the change with the [OK] button.

10 Monitoring Value Descriptions

10.1 Multimonitor

10.1.1 (ID 25) Frequency Reference

- Location in the menu with default settings: **V2.1.1** (In *Multimonitor* menu)
- Location in the menu: **V2.3.2** (In *Basic* menu)

This monitoring value shows the actual frequency reference to the motor control.
The value is updated at 10 ms interval.

10.1.2 (ID 1) Output Frequency

- Location in the menu with default settings: **V2.1.2** (In *Multimonitor* menu)
- Location in the menu: **V2.3.1** (In *Basic* menu)

This monitoring value shows the actual output frequency to the motor.

10.1.3 (ID 3) Motor Current

- Location in the menu with default settings: **V2.1.3** (In *Multimonitor* menu)
- Location in the menu: **V2.3.4** (In *Basic* menu)

This monitoring value shows the measured current of the motor.
The scaling of the value is different for different drive sizes.

10.1.4 (ID 2) Motor Speed

- Location in the menu with default settings: **V2.1.4** (In *Multimonitor* menu)
- Location in the menu: **V2.3.3** (In *Basic* menu)

This monitoring value shows the actual speed of the motor in RPM (calculated value).

10.1.5 (ID 5) Motor Shaft Power

- Location in the menu with default settings: **V2.1.5** (In *Multimonitor* menu)
- Location in the menu: **V2.3.7** (In *Basic* menu)

This monitoring value shows the actual shaft power of the motor (calculated value) as a percentage of the motor nominal power.

10.1.6 (ID 8) Unit Temperature

- Location in the menu with default settings: **V2.1.6** (In *Multimonitor* menu)
- Location in the menu: **V2.3.11** (In *Basic* menu)

This monitoring value shows the measured heat sink temperature of the drive.
The unit of measurement is degrees Celsius or Fahrenheit, depending on parameter C/F Selection (ID 1197) value.

10.1.7 (ID 7) DC Link Voltage

- Location in the menu with default settings: **V2.1.7** (In *Multimonitor* menu)
- Location in the menu: **V2.3.10** (In *Basic* menu)

This monitoring value shows the measured voltage in the DC link of the drive.

10.1.8 (ID 4) Motor Torque

- Location in the menu with default settings: **V2.1.8** (In *Multimonitor* menu)
- Location in the menu: **V2.3.5** (In *Basic* menu)

This monitoring value shows the actual torque of the motor (calculated value).

10.1.9 (ID 6) Motor Voltage

- Location in the menu with default settings: **V2.1.9** (In *Multimonitor* menu)
- Location in the menu: **V2.3.9** (In *Basic* menu)

This monitoring value shows the actual output voltage to the motor.

10.2 Basic

10.2.1 (ID 1) Output Frequency

- Location in the menu with default settings: **V2.1.2** (In *Multimonitor* menu)
- Location in the menu: **V2.3.1** (In *Basic* menu)

This monitoring value shows the actual output frequency to the motor.

10.2.2 (ID 25) Frequency Reference

- Location in the menu with default settings: **V2.1.1** (In *Multimonitor* menu)
- Location in the menu: **V2.3.2** (In *Basic* menu)

This monitoring value shows the actual frequency reference to the motor control.

The value is updated at 10 ms interval.

10.2.3 (ID 2) Motor Speed

- Location in the menu with default settings: **V2.1.4** (In *Multimonitor* menu)
- Location in the menu: **V2.3.3** (In *Basic* menu)

This monitoring value shows the actual speed of the motor in RPM (calculated value).

10.2.4 (ID 3) Motor Current

- Location in the menu with default settings: **V2.1.3** (In *Multimonitor* menu)
- Location in the menu: **V2.3.4** (In *Basic* menu)

This monitoring value shows the measured current of the motor.

The scaling of the value is different for different drive sizes.

10.2.5 (ID 4) Motor Torque

- Location in the menu with default settings: **V2.1.8** (In *Multimonitor* menu)
- Location in the menu: **V2.3.5** (In *Basic* menu)

This monitoring value shows the actual torque of the motor (calculated value).

10.2.6 (ID 5) Motor Shaft Power

- Location in the menu with default settings: **V2.1.5** (In *Multimonitor* menu)
- Location in the menu: **V2.3.7** (In *Basic* menu)

This monitoring value shows the actual shaft power of the motor (calculated value) as a percentage of the motor nominal power.

10.2.7 (ID 73) Motor Shaft Power

Location in the menu: **V2.3.8**

This monitoring value shows the actual shaft power of the motor (calculated value). The unit of measurement is kW or hp, depending on parameter kW/hp Selection (ID 1198) value.

The number of decimals in the value of this monitoring value varies depending on the size of the AC drive. In fieldbus control, ID 15592 can be mapped as Process Data Out to determine how many decimals are used. The last significant digit tells the amount of decimals.

10.2.8 (ID 6) Motor Voltage

- Location in the menu with default settings: **V2.1.9** (In *Multimonitor* menu)
- Location in the menu: **V2.3.9** (In *Basic* menu)

This monitoring value shows the actual output voltage to the motor.

10.2.9 (ID 7) DC Link Voltage

- Location in the menu with default settings: **V2.1.7** (In *Multimonitor* menu)
- Location in the menu: **V2.3.10** (In *Basic* menu)

This monitoring value shows the measured voltage in the DC link of the drive.

10.2.10 (ID 8) Unit Temperature

- Location in the menu with default settings: **V2.1.6** (In *Multimonitor* menu)
- Location in the menu: **V2.3.11** (In *Basic* menu)

This monitoring value shows the measured heat sink temperature of the drive.

The unit of measurement is degrees Celsius or Fahrenheit, depending on parameter C/F Selection (ID 1197) value.

10.2.11 (ID 9) Motor Temperature

Location in the menu: **V2.3.12**

This monitoring value shows the calculated motor temperature in percentage of the nominal working temperature.

When the value rises above 105%, motor thermal protection fault occurs.

10.2.12 (ID 1228) Motor Preheat

Location in the menu: **V2.3.13**

This monitoring value shows the status of the motor preheat function.

10.2.13 (ID 1054) kWh Trip Counter Low

Location in the menu: **V2.3.15**

This monitoring value shows the actual value of the kWh counter (energy counter). When the value of the counter goes higher than 65535, the counter is restarted from 0.

10.2.14 (ID 1067) kWh Trip Counter High

Location in the menu: **V2.3.16**

This monitoring value shows how many times the kWh counter (energy counter) has spun around.

10.3 I/O

10.3.1 (ID 15) SlotA DIN 1,2,3

Location in the menu: **V2.4.1**

This monitoring value shows the status of the digital inputs 1–3 in slot A (standard I/O).

10.3.2 (ID 16) SlotA DIN 4,5,6

Location in the menu: **V2.4.2**

This monitoring value shows the status of the digital inputs 4–6 in slot A (standard I/O).

10.3.3 (ID 17) SlotB RO 1,2,3

Location in the menu: **V2.4.3**

This monitoring value shows the status of the relay outputs 1–3 in slot B.

10.3.4 (ID 59) Analog Input 1

Location in the menu: **V2.4.4**

This monitoring value shows the value of the analog input signal as a percentage of the used range.

10.3.5 (ID 60) Analog Input 2

Location in the menu: **V2.4.5**

This monitoring value shows the value of the analog input signal as a percentage of the used range.

10.3.6 (ID 61) Analog Input 3

Location in the menu: **V2.4.6**

This monitoring value shows the value of the analog input signal as a percentage of the used range.

10.3.7 (ID 62) Analog Input 4

Location in the menu: **V2.4.7**

This monitoring value shows the value of the analog input signal as a percentage of the used range.

10.3.8 (ID 75) Analog Input 5

Location in the menu: **V2.4.8**

This monitoring value shows the value of the analog input signal as a percentage of the used range.

10.3.9 (ID 76) Analog Input 6

Location in the menu: **V2.4.9**

This monitoring value shows the value of the analog input signal as a percentage of the used range.

10.3.10 (ID 81) SlotA AO 1

Location in the menu: **V2.4.10**

This monitoring value shows the value of the analog output as a percentage of the used range.

10.4 Temperature Inputs

The monitoring values related to temperature input settings are only available if a B8 or BH option board is installed.

10.4.1 (ID 50) Temperature Input 1

Location in the menu: **V2.5.1i**

This monitoring value shows the measured value of the temperature. The unit of the monitoring value is degrees Celsius or Fahrenheit, depending on parameter C/F Selection (ID 1197) value.

The list of temperature inputs is made of the first 6 available temperature inputs. The list starts from slot A and ends in slot E. If an input is available but no sensor is connected, the list shows the maximum value because the measured resistance is endless. To make the value go to its minimum value, hardwire the input.

10.4.2 (ID 51) Temperature Input 2

Location in the menu: **V2.5.2**

This monitoring value shows the measured value of the temperature. The unit of the monitoring value is degrees Celsius or Fahrenheit, depending on parameter C/F Selection (ID 1197) value.

10.4.3 (ID 52) Temperature Input 3

Location in the menu: **V2.5.3**

This monitoring value shows the measured value of the temperature. The unit of the monitoring value is degrees Celsius or Fahrenheit, depending on parameter C/F Selection (ID 1197) value.

10.4.4 (ID 69) Temperature Input 4

Location in the menu: **V2.5.4**

This monitoring value shows the measured value of the temperature. The unit of the monitoring value is degrees Celsius or Fahrenheit, depending on parameter C/F Selection (ID 1197) value.

10.4.5 (ID 70) Temperature Input 5

Location in the menu: **V2.5.5**

This monitoring value shows the measured value of the temperature. The unit of the monitoring value is degrees Celsius or Fahrenheit, depending on parameter C/F Selection (ID 1197) value.

10.4.6 (ID 71) Temperature Input 6

Location in the menu: **V2.5.6**

This monitoring value shows the measured value of the temperature. The unit of the monitoring value is degrees Celsius or Fahrenheit, depending on parameter C/F Selection (ID 1197) value.

10.5 Extras and Advanced

10.5.1 (ID 43) Drive Status Word

Location in the menu: **V2.6.1**

This monitoring value shows the bit-coded status of the drive.

10.5.2 (ID 78) Ready Status

Location in the menu: **V2.6.2**

This monitoring value shows the bit-coded data about the Ready criteria of the drive. This data is useful for monitoring when the drive is not in the Ready state.

NOTICE

The values are visible as checkboxes on the graphical display. If a box is selected, the value is active.

10.5.3 (ID 89) Application Status Word 1

Location in the menu: **V2.6.3**

This monitoring value shows the bit-coded statuses of the application.

NOTICE

The values are visible as checkboxes on the graphical display. If a box is selected, the value is active.

10.5.4 (ID 90) Application Status Word 2

Location in the menu: **V2.6.4**

This monitoring value shows the bit-coded statuses of the application.

NOTICE

The values are visible as checkboxes on the graphical display. If a box is selected, the value is active.

10.5.5 (ID 56) DIN Status Word 1

Location in the menu: **V2.6.5**

This monitoring value shows the bit-coded status of the digital input signals.

The monitoring value is a 16-bit word, where each bit shows the status of 1 digital input. From each slot, 6 digital inputs are read. Word 1 starts from the input 1 in slot A (bit0) and ends with input 4 in slot C (bit15).

10.5.6 (ID 57) DIN Status Word 2

Location in the menu: **V2.6.6**

This monitoring value shows the bit-coded status of the digital input signals.

The monitoring value is a 16-bit word, where each bit shows the status of 1 digital input. From each slot, 6 digital inputs are read. Word 2 starts from the input 5 in slot C (bit0) and ends with input 6 in slot E (bit13).

10.5.7 (ID 45) Motor Current 1 Deci

Location in the menu: **V2.6.7**

This monitoring value shows the measured current of the motor with the fixed number of decimals and that is less filtered. This monitoring value can be used, for example, with fieldbus to get the correct value so that the enclosure size does not have an effect. It can also be used for monitoring when less filtering time is needed for the motor current.

10.5.8 (ID 1495) Frequency Reference Source

Location in the menu: **V2.6.8**

This monitoring value shows the momentary frequency reference source.

10.5.9 (ID 37) Last Active Fault Code

Location in the menu: **V2.6.9**

This monitoring value shows the fault code of latest activated fault that is not reset.

10.5.10 (ID 95) Last Active Fault ID

Location in the menu: **V2.6.10**

This monitoring value shows the fault ID of latest activated fault that is not reset.

10.5.11 (ID 74) Last Active Alarm Code

Location in the menu: **V2.6.11**

This monitoring value shows the alarm code of latest activated alarm that is not reset.

10.5.12 (ID 94) Last Active Alarm ID

Location in the menu: **V2.6.12**

This monitoring value shows the alarm ID of latest activated alarm that is not reset.

10.5.13 (ID 77) Motor Regulator Status

Location in the menu: **V2.6.13**

This monitoring value shows the bit-coded status of the motor limit controllers.

NOTICE

The values are visible as checkboxes on the graphical display. If a box is selected, the limit controller is active.

10.5.14 (ID 98) Motor Shaft Power 1 Decimal

Location in the menu: **V2.6.14**

This monitoring value shows the actual shaft power of the motor (calculated value with one decimal). The unit of measurement is kW or hp, depending on parameter kW/hp Selection (ID 1198) value.

10.6 Timer Functions

10.6.1 (ID 1441) TC 1, TC 2, TC 3

Location in the menu: **V2.7.1**

This monitoring value shows the status of the time channels 1, 2 and 3.

10.6.2 (ID 1442) Interval 1

Location in the menu: **V2.7.2**

This monitoring value shows the status of the interval function.

10.6.3 (ID 1443) Interval 2

Location in the menu: **V2.7.3**

This monitoring value shows the status of the interval function.

10.6.4 (ID 1444) Interval 3

Location in the menu: **V2.7.4**

This monitoring value shows the status of the interval function.

10.6.5 (ID 1445) Interval 4

Location in the menu: **V2.7.5**

This monitoring value shows the status of the interval function.

10.6.6 (ID 1446) Interval 5

Location in the menu: **V2.7.6**

This monitoring value shows the status of the interval function.

10.6.7 (ID 1447) Timer 1

Location in the menu: **V2.7.7**

The monitoring value shows the remaining time on the timer if the timer is active.

10.6.8 (ID 1448) Timer 2

Location in the menu: **V2.7.8**

The monitoring value shows the remaining time on the timer if the timer is active.

10.6.9 (ID 1449) Timer 3

Location in the menu: **V2.7.9**

The monitoring value shows the remaining time on the timer if the timer is active.

10.6.10 (ID 1450) Real-time Clock

Location in the menu: **V2.7.10**

This monitoring value shows the actual time of the real-time clock in a format of hh:mm:ss.

10.7 PID Controller

10.7.1 (ID 20) PID Setpoint

Location in the menu: **V2.8.1**

This monitoring value shows the value of the PID setpoint signal in process units. Use the parameter P3.13.1.7 to select the process unit (See [11.15.1.4 \(ID 1036\) Process Unit Selection](#)).

10.7.2 (ID 21) PID Feedback

Location in the menu: **V2.8.2**

This monitoring value shows the value of the PID feedback signal in process units. Use the parameter P3.13.1.7 to select the process unit (See [11.15.1.4 \(ID 1036\) Process Unit Selection](#)).

10.7.3 (ID 15541) PID Feedback (1)

Location in the menu: **V2.8.3**

This monitoring value shows the value of the PID feedback signal 1 in process units.

10.7.4 (ID 15542) PID Feedback (2)

Location in the menu: **V2.8.4**

This monitoring value shows the value of the PID feedback signal 2 in process units.

10.7.5 (ID 22) PID Error

Location in the menu: **V2.8.5**

This monitoring value shows the error value of the PID controller.

The error value is the deviation of PID feedback from the PID setpoint in process unit. Use the parameter P3.13.1.7 to select the process unit (See [11.15.1.4 \(ID 1036\) Process Unit Selection](#)).

10.7.6 (ID 23) PID Output

Location in the menu: **V2.8.6**

This monitoring value shows the output of the PID controller as a percentage (0–100%).

Give this value to the motor control (frequency reference) or to an analog output.

10.7.7 (ID 24) PID Status

Location in the menu: **V2.8.7**

This monitoring value shows the state of the PID controller.

10.8 External PID Controller

10.8.1 (ID 83) EXTPID Setpoint

Location in the menu: **V2.9.1**

This monitoring value shows the value of the PID setpoint signal in process units. Use the parameter P3.14.1.10 to select the process unit (See [11.15.1.7 \(ID 1035\) Process Unit Decimals](#)).

10.8.2 (ID 85) EXTPID Error

Location in the menu: **V2.9.3**

This monitoring value shows the error value of the PID controller. The error value is the deviation of PID feedback from the PID setpoint in process unit. Use the parameter P3.14.1.10 to select the process unit (See [11.15.1.7 \(ID 1035\) Process Unit Decimals](#)).

10.8.3 (ID 84) EXTPID Feedback

Location in the menu: **V2.9.2**

This monitoring value shows the value of the PID feedback signal in process units. Use the parameter P3.14.1.10 to select the process unit (See [11.15.1.7 \(ID 1035\) Process Unit Decimals](#)).

10.8.4 (ID 86) EXTPID Output

Location in the menu: **V2.9.4**

This monitoring value shows the output of the PID controller as a percentage (0–100%). Give this value to, for example, the analog output.

10.8.5 (ID 87) EXTPID Status

Location in the menu: **V2.9.5**

This monitoring value shows the state of the PID controller.

10.9 Multi-pump

10.9.1 (ID 30) Motors Running

Location in the menu: **V2.10.1**

This monitoring value shows the actual number of motors that operate in the Multi-pump system.

10.9.2 (ID 1114) Autochange

Location in the menu: **V2.10.2**

This monitoring value shows the status of the autochange requested.

10.9.3 (ID 1503) Next Autochange

Location in the menu: **V2.10.3**

This monitoring value shows the time that remains to next autochange.

10.9.4 (ID 1505) Operate Mode

Location in the menu: **V2.10.4**

This monitoring value shows the operation mode of the drive in the Multi-pump system.

10.9.5 (ID 1628) Multi-pump Status

Location in the menu: **V2.10.5**

This monitoring value shows the status of the drive in the Multi-pump system.

10.9.6 (ID 1629) Communication Status

Location in the menu: **V2.10.6**

This monitoring value shows status of the communication between the drives in the Multi-pump system.

10.9.7 (ID 1620) Pump (1) Running Time

Location in the menu: **V2.10.7**

This monitoring value shows the operating hours of the pump in Multi-pump system.

10.9.8 (ID 1621) Pump (2) Running Time

Location in the menu: **V2.10.8**

This monitoring value shows the operating hours of the pump in Multi-pump system.

10.9.9 (ID 1622) Pump (3) Running Time

Location in the menu: **V2.10.9**

This monitoring value shows the operating hours of the pump in Multi-pump system.

10.9.10 (ID 1623) Pump (4) Running Time

Location in the menu: **V2.10.10**

This monitoring value shows the operating hours of the pump in Multi-pump system.

10.9.11 (ID 1624) Pump (5) Running Time

Location in the menu: **V2.10.11**

This monitoring value shows the operating hours of the pump in Multi-pump system.

10.9.12 (ID 1625) Pump (6) Running Time

Location in the menu: **V2.10.12**

This monitoring value shows the operating hours of the pump in Multi-pump system.

10.9.13 (ID 1626) Pump (7) Running Time

Location in the menu: **V2.10.13**

This monitoring value shows the operating hours of the pump in Multi-pump system.

10.9.14 (ID 1627) Pump (8) Running Time

Location in the menu: **V2.10.14**

This monitoring value shows the operating hours of the pump in Multi-pump system.

10.10 Maintenance Counters

10.10.1 (ID 1101) Maintenance Counter 1

Location in the menu: **V2.11.1**

This monitoring value shows the status of the maintenance counter. The status of the maintenance counter is shown as revolutions multiplied by 1000, or in hours. For the configuration and activation of this counter, see [11.18.1 The Maintenance Counters](#).

10.11 Fieldbus Data

10.11.1 (ID 874) FB Control Word

Location in the menu: **V2.12.1**

This monitoring value shows the status of the fieldbus control word that the application uses in bypass mode. Depending on the fieldbus type or profile, the data that is received from the fieldbus can be modified before it is sent to the application.

Bit	Value = 0 (FALSE)	Value = 1 (TRUE)
Bit 0	Stop request from Fieldbus	Start request from Fieldbus
Bit 1	Forward direction request	Reverse direction request
Bit 2	No action	Reset active faults and alarms (on rising edge 0->1)
Bit 3	No action	Force stop mode to Coasting
Bit 4	No action	Force stop mode to Ramping
Bit 5	No action (normal deceleration ramp time)	Force drive to use fast deceleration ramp time (1/3 of normal deceleration time)
Bit 6	No action	Freeze drive frequency reference
Bit 7	No action	Force Fieldbus frequency reference to zero
Bit 8	No action	Force drive control place to Fieldbus control
Bit 9	No action	Force drive reference source to Fieldbus reference
Bit 10	Reserved	Reserved
Bit 11	Reserved	Reserved
Bit 12	No action	Activate Quick Stop function NOTE! This stops the drive according to setting in parameter menu M3.9.5.
Bit 13	Reserved	Reserved
Bit 14	Reserved	Reserved
Bit 15	Reserved	Reserved

10.11.2 (ID 875) FB Speed Reference

Location in the menu: **V2.12.2**

This monitoring value shows the fieldbus frequency reference as a percentage of minimum frequency to maximum frequency. The speed reference information is scaled between the minimum and the maximum frequency at the moment when the application received it. The minimum and the maximum frequencies can be changed after the application received the reference without an effect on the reference.

10.11.3 (ID 876) FB Data IN 1

Location in the menu: **V2.12.3**

This monitoring value shows the raw value of process data in a 32-bit signed format.

10.11.4 (ID 877) FB Data IN 2

Location in the menu: **V2.12.4**

This monitoring value shows the raw value of process data in a 32-bit signed format.

10.11.5 (ID 878) FB Data IN 3

Location in the menu: **V2.12.5**

This monitoring value shows the raw value of process data in a 32-bit signed format.

10.11.6 (ID 879) FB Data IN 4

Location in the menu: **V2.12.6**

This monitoring value shows the raw value of process data in a 32-bit signed format.

10.11.7 (ID 880) FB Data IN 5

Location in the menu: **V2.12.7**

This monitoring value shows the raw value of process data in a 32-bit signed format.

10.11.8 (ID 881) FB Data IN 6

Location in the menu: **V2.12.8**

This monitoring value shows the raw value of process data in a 32-bit signed format.

10.11.9 (ID 882) FB Data IN 7

Location in the menu: **V2.12.9**

This monitoring value shows the raw value of process data in a 32-bit signed format.

10.11.10 (ID 883) FB Data IN 8

Location in the menu: **V2.12.10**

This monitoring value shows the raw value of process data in a 32-bit signed format.

10.11.11 (ID 864) FB Status Word

Location in the menu: **V2.12.11**

This monitoring value shows the status of the fieldbus status word that the application uses in bypass mode. Depending on the fieldbus type or profile, the data can be modified before it is sent to the fieldbus.

Bit	Value = 0 (FALSE)	Value = 1 (TRUE)
Bit 0	Not ready to operate	Ready to operate
Bit 1	Not running	Running
Bit 2	Behavior depends on P3.6.17.	Behavior depends on P3.6.17.
Bit 3	No fault	Fault is active
Bit 4	No alarm	Alarm is active
Bit 5	Requested speed not reached	Running at requested speed
Bit 6	Actual speed of the drive not zero	Actual speed of the drive is zero
Bit 7	Motor not magnetized (flux not ready)	Motor magnetized (flux ready)
Bit 8	Reserved	Reserved
Bit 9	Reserved	Reserved
Bit 10	Reserved	Reserved
Bit 11	Reserved	Reserved
Bit 12	Reserved	Reserved
Bit 13	Reserved	Reserved
Bit 14	Reserved	Reserved
Bit 15	Reserved	Reserved

10.11.12 (ID 865) FB Speed Actual

Location in the menu: **V2.12.12**

This monitoring value shows the actual speed of the drive as a percentage of minimum frequency and maximum frequency. The value 0% indicates the minimum frequency and the value 100% indicates the maximum frequency. This monitoring value is continuously updated depending on the momentary min and max frequencies and the output frequency.

10.11.13 (ID 866) FB Data OUT 1

Location in the menu: **V2.12.13**

This monitoring value shows the raw value of process data in a 32-bit signed format.

10.11.14 (ID 867) FB Data OUT 2

Location in the menu: **V2.12.13**

This monitoring value shows the raw value of process data in a 32-bit signed format.

10.11.15 (ID 868) FB Data OUT 3

Location in the menu: **V2.12.15**

This monitoring value shows the raw value of process data in a 32-bit signed format.

10.11.16 (ID 869) FB Data OUT 4

Location in the menu: **V2.12.16**

This monitoring value shows the raw value of process data in a 32-bit signed format.

10.11.17 (ID 870) FB Data OUT 5

Location in the menu: **V2.12.17**

This monitoring value shows the raw value of process data in a 32-bit signed format.

10.11.18 (ID 871) FB Data OUT 6

Location in the menu: **V2.12.18**

This monitoring value shows the raw value of process data in a 32-bit signed format.

10.11.19 (ID 872) FB Data OUT 7

Location in the menu: **V2.12.19**

This monitoring value shows the raw value of process data in a 32-bit signed format.

10.11.20 (ID 873) FB Data OUT 8

Location in the menu: **V2.12.20**

This monitoring value shows the raw value of process data in a 32-bit signed format.

10.12 Drive Customizer

10.12.1 (ID 15020) Block Out.1

Location in the menu: **V2.13.2**

This monitoring value shows the value of the function block output in the Drive customizer function.

10.12.2 (ID 15040) Block Out.2

Location in the menu: **V2.13.3**

This monitoring value shows the value of the function block output in the Drive customizer function.

10.12.3 (ID 15060) Block Out.3

Location in the menu: **V2.13.4**

This monitoring value shows the value of the function block output in the Drive customizer function.

10.12.4 (ID 15080) Block Out.4

Location in the menu: **V2.13.5**

This monitoring value shows the value of the function block output in the Drive customizer function.

10.12.5 (ID 15100) Block Out.5

Location in the menu: **V2.13.6**

This monitoring value shows the value of the function block output in the Drive customizer function.

10.12.6 (ID 15120) Block Out.6

Location in the menu: **V2.13.7**

This monitoring value shows the value of the function block output in the Drive customizer function.

10.12.7 (ID 15140) Block Out.7

Location in the menu: **V2.13.8**

This monitoring value shows the value of the function block output in the Drive customizer function.

10.12.8 (ID 15160) Block Out.8

Location in the menu: **V2.13.9**

This monitoring value shows the value of the function block output in the Drive customizer function.

10.12.9 (ID 15180) Block Out.9

Location in the menu: **V2.13.10**

This monitoring value shows the value of the function block output in the Drive customizer function.

10.12.10 (ID 15200) Block Out.10

Location in the menu: **V2.13.11**

This monitoring value shows the value of the function block output in the Drive customizer function.

10.13 Condition-based Monitoring

10.13.1 Baseline Data

10.13.1.1 (ID 3601) Baseline Data Element 1

Location in the menu: **V2.16.1.1**

This monitoring value shows the baseline data. The baseline data is selected using the baseline data selector.

10.13.1.2 (ID 3602) Baseline Data Element 2

Location in the menu: **V2.16.1.2**

This monitoring value shows the baseline data. The baseline data is selected using the baseline data selector.

10.13.1.3 (ID 3603) Baseline Data Element 3

Location in the menu: **V2.16.1.3**

This monitoring value shows the baseline data. The baseline data is selected using the baseline data selector.

10.13.1.4 (ID 3604) Baseline Data Element 4

Location in the menu: **V2.16.1.4**

This monitoring value shows the baseline data. The baseline data is selected using the baseline data selector.

10.13.1.5 (ID 3605) Baseline Data Element 5

Location in the menu: **V2.16.1.5**

This monitoring value shows the baseline data. The baseline data is selected using the baseline data selector.

10.13.1.6 (ID 3606) Baseline Data Element 6

Location in the menu: **V2.16.1.6**

This monitoring value shows the baseline data. The baseline data is selected using the baseline data selector.

10.13.1.7 (ID 3607) Baseline Data Element 7

Location in the menu: **V2.16.1.7**

This monitoring value shows the baseline data. The baseline data is selected using the baseline data selector.

10.13.1.8 (ID 3608) Baseline Data Element 8

Location in the menu: **V2.16.1.8**

This monitoring value shows the baseline data. The baseline data is selected using the baseline data selector.

10.13.1.9 (ID 3609) Baseline Data Element 9

Location in the menu: **V2.16.1.9**

This monitoring value shows the baseline data. The baseline data is selected using the baseline data selector.

10.13.1.10 (ID 3610) Baseline Data Element 10

Location in the menu: **V2.16.1.10**

This monitoring value shows the baseline data. The baseline data is selected using the baseline data selector.

10.13.1.11 (ID 3622) Baseline Run Status

Location in the menu: **V2.16.1.11**

This monitoring value shows the baseline run status.

10.13.2 Stator Winding Monitor

10.13.2.1 (ID 3617) Current Unbalance

Location in the menu: **V2.16.2.1**

This monitoring value shows the current unbalance when condition-based monitoring is activated.

10.13.2.2 (ID 3620) Current Unbalance Threshold Value

Location in the menu: **V2.16.2.2**

This monitoring value shows the threshold value after interpolating.

10.13.2.3 (ID 3611) Current Warning S1 High Threshold

Location in the menu: **V2.16.2.3**

This monitoring value shows the warning S1 high threshold value.

10.13.2.4 (ID 3612) Current Warning S2 High Threshold

Location in the menu: **V2.16.2.4**

This monitoring value shows the warning S2 high threshold value.

10.13.2.5 (ID 3613) Current Alarm High Threshold

Location in the menu: **V2.16.2.5**

This monitoring value shows the alarm/fault high threshold value.

10.13.3 Vibration

10.13.3.1 (ID 3623) Vibration

Location in the menu: **V2.16.3.1**

This monitoring value shows the vibration when condition-based monitoring is activated.

10.13.3.2 (ID 3624) Vibration Threshold Value

Location in the menu: **V2.16.3.2**

This monitoring value shows the threshold value after interpolating.

10.13.3.3 (ID 3625) Vibration S1 High Threshold

Location in the menu: **V2.16.3.3**

This monitoring value shows the warning S1 high threshold value.

10.13.3.4 (ID 3626) Vibration S2 High Threshold

Location in the menu: **V2.16.3.4**

This monitoring value shows the warning S2 high threshold value.

10.13.3.5 (ID 3627) Vibration Alarm High Threshold

Location in the menu: **V2.16.3.5**

This monitoring value shows the alarm/fault high threshold value.

10.13.4 Load

10.13.4.1 (ID 3628) Load Threshold Value

Location in the menu: **V2.16.4.2**

This monitoring value shows the threshold value after interpolating.

10.13.4.2 (ID 3629) Load S1 High Threshold

Location in the menu: **V2.16.4.3**

This monitoring value shows the warning S1 high threshold value.

10.13.4.3 (ID 3630) Load S2 High Threshold

Location in the menu: **V2.16.4.4**

This monitoring value shows the warning S2 high threshold value.

10.13.4.4 (ID 3631) Load Alarm High Threshold

Location in the menu: **V2.16.4.5**

This monitoring value shows the alarm/fault high threshold value.

10.13.4.5 (ID 3632) Load S1 Low Threshold

Location in the menu: **V2.16.4.6**

This monitoring value shows the warning S1 low threshold value.

10.13.4.6 (ID 3633) Load S2 Low Threshold

Location in the menu: **V2.16.4.7**

This monitoring value shows the warning S2 low threshold value.

10.13.4.7 (ID 3634) Load Alarm Low Threshold

Location in the menu: **V2.16.4.8**

This monitoring value shows the alarm/fault low threshold value.

10.13.5 (ID 3619) Condition-based Monitoring Status

Location in the menu: **V2.16.5**

This monitoring value shows the fault status of the condition-based monitoring.

11 Parameter Descriptions

11.1 (ID 212) Application

Location in the menu: **P1.2**

Use this parameter to select the application configuration for the drive. The applications include preset application configurations, that is, sets of predefined parameters. The selection of the application makes the commissioning of the drive easy and reduces the manual work with the parameters.

⚠ WARNING ⚠

ACCIDENTAL START BECAUSE OF CHANGE OF SETTINGS

Running the Startup wizard, changing the application or the software can cause the I/O functions to change.

- Disconnect the motor from the drive if an accidental start can be dangerous.

When the value of this parameter changes, a parameter groups get their preset values. The value of this parameter can be changed when the starting up or commissioning the drive.

If this parameter is changed in the control panel, an application wizard starts and helps to set the basic parameters related to the application. The wizard does not start, when using the PC tool to change this parameter. For more data about the application wizards, see [4.1 Application Wizards](#).

These applications are available:

- 0 = Standard
- 1 = HVAC
- 3 = PID control
- 4 = Multi-ump (single drive)
- 5 = Multi-ump (multidrive)

N O T I C E

When the application is changed, the contents of the Quick Setup menu change.

11.2 Trend Curve

11.2.1 (ID 2368) Sampling Interval

Location in the menu: **P2.2.2**

Use this parameter to set the sampling interval.

11.2.2 (ID 2369) Channel 1 MIN

Location in the menu: **P2.2.3**

This parameter is used in scaling by default. Adjustments can be necessary.

11.2.3 (ID 2370) Channel 1 MAX

Location in the menu: **P2.2.4**

This parameter is used in scaling by default. Adjustments can be necessary.

11.2.4 (ID 2371) Channel 2 MIN

Location in the menu: **P2.2.5**

This parameter is used in scaling by default. Adjustments can be necessary.

11.2.5 (ID 2372) Channel 2 MAX

Location in the menu: **P2.2.6**

This parameter is used in scaling by default. Adjustments can be necessary.

11.2.6 (ID 2373) Autoscale

Location in the menu: **P2.2.7**

Use this parameter to set autoscaling on or off. If autoscaling is enabled, the signal is automatically scaled between the minimum and maximum values.

11.3 Motor Settings

11.3.1 Motor Nameplate Parameters

11.3.1.1 (ID 110) Motor Nominal Voltage

Location in the menu: **P3.1.1.1**

Find the value U_n on the nameplate of the motor. Find out whether the motor connection is Delta or Star.

11.3.1.2 (ID 111) Motor Nominal Frequency

Location in the menu: **P3.1.1.2**

Find the value f_n on the nameplate of the motor.

When this parameter changes, parameters **P3.1.4.2 Field Weakening Point Frequency** and **P3.1.4.3 Voltage at Field Weakening Point** start automatically. The 2 parameters have different values for each motor type. See [11.3.2.1 \(ID 650\) Motor Type](#).

11.3.1.3 (ID 112) Motor Nominal Speed

Location in the menu: **P3.1.1.3**

Find the value n_n on the nameplate of the motor.

11.3.1.4 (ID 113) Motor Nominal Current

Location in the menu: **P3.1.1.4**

Find the value I_n on the nameplate of the motor.

11.3.1.5 (ID 120) Motor Cos Phi

Location in the menu: **P3.1.1.5**

Find the value on the nameplate of the motor.

11.3.1.6 (ID 116) Motor Nominal Power

Location in the menu: **P3.1.1.6**

Find the value P_n on the nameplate of the motor.

11.3.2 Motor Control Parameters

11.3.2.1 (ID 650) Motor Type

Location in the menu: **P3.1.2.2**

Use this parameter to set the type of motor in the process.

Selection number	Selection name	Description
0	Induction motor (IM)	Make this selection if an induction motor is in use.
1	Permanent Magnet Motor (PM)	Make this selection if permanent magnet motor is in use.
2	Reluctance Motor	Make this selection if a reluctance motor is in use.

When the value of parameter **P3.1.2.2 Motor Type** is changed, the values of parameters **P3.1.4.2 Field Weakening Point Frequency** and **P3.1.4.3 Voltage at Field Weakening Point** change automatically. See the following table. The 2 parameters have different values for each motor type.

Parameter	Induction motor (IM)	Permanent magnet motor (PM)
P3.1.4.2 (Field Weakening Point Frequency)	Motor nominal frequency	Internally calculated
P3.1.4.3 (Voltage at Field Weakening Point)	100.0%	Internally calculated

11.3.2.2 (ID 601) Switching Frequency

Location in the menu: **P3.1.2.3**

Use this parameter to set the switching frequency of the AC drive.

If the switching frequency is increased, the capacity of the AC drive reduces. To reduce capacitive currents in the motor cable, when the cable is long, we recommend using a low switching frequency. To reduce the motor noise, use a high switching frequency.

11.3.2.3 (ID 631) Identification

Location in the menu: **P3.1.2.4**

Use this parameter to find the parameter values that are optimal for the operation of the drive.

The identification run calculates or measures the motor parameters that are necessary for a good control of the motor and speed. The identification run helps to adjust the motor-specific and the drive-specific parameters. It is a tool for the commissioning and the servicing of the drive.

N O T I C E

Before the identification run, set the motor nameplate parameters.

Selection number	Selection name	Description
0	No action	No identification requested.
1	Identification at standstill	The drive operates without speed when doing the identification run for the motor parameters. The motor receives current and voltage, but the frequency is zero. The U/f ratio and start magnetization parameters are identified.
2	Identification with rotation	The drive operates with speed when doing the identification run for the motor parameters. The U/f ratio, the magnetization current and start magnetization parameters are identified. To get accurate results, do this identification run with no load on the motor shaft.

To activate the Identification function, set the parameter P3.1.2.4 and give a start command. The start command must be given in 20 s. If there is no start command in that time, the identification run does not start. The parameter P3.1.2.4 is reset to the default value and an identification alarm shows.

To stop the identification run before it is completed, give a stop command. This resets the parameter to the default value. If the identification run is not completed, an identification alarm shows.

N O T I C E

To start the drive after the identification, a new start command is necessary.

11.3.2.4 (ID 612) Magnetizing Current

Location in the menu: **P3.1.2.5**

Use this parameter to set the magnetizing current of the motor.

The magnetizing current (no-load current) of the motor identifies the values of the U/f parameters when they are given before the identification run. If the value is set to 0, the magnetizing current is calculated internally.

11.3.2.5 (ID 653) Motor Switch

Location in the menu: **P3.1.2.6**

Use this parameter to enable the Motor Switch function. Use the Motor Switch function, if the cable that connects the motor and the drive has a motor switch. The operation of the motor switch makes sure that the motor is isolated from the voltage source and does not start during the servicing.

To activate the function, set the parameter P3.1.2.6 to the value Enabled. The drive stops automatically when the motor switch is opened, and the drive starts automatically when the motor switch is closed. The drive does not trip when using the Motor switch function.

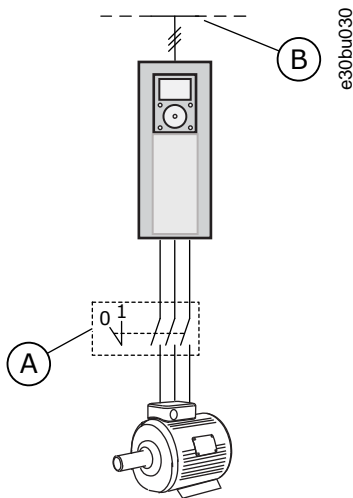

Illustration 35: The Motor Switch Between the Drive and the Motor

A	The motor switch
B	Mains

11.3.2.6 (ID 607) Overvoltage Control

Location in the menu: **P3.1.2.10**

Use this parameter to set the overvoltage controller out of operation.

The function is necessary when

- the supply voltage changes, for example, between -15% and +10%, and
- the controlled process does not have the tolerance for the changes that the undervoltage controller and the overvoltage controller make to the output frequency of the drive.

The overvoltage controller increases the output frequency of the drive

- to keep the DC link voltage in the permitted limits, and
- to make sure that the drive does not trip because of an overvoltage fault.

N O T I C E

The drive can trip when the overvoltage and undervoltage controllers are disabled.

11.3.2.7 (ID 608) Undervoltage Control

Location in the menu: **P3.1.2.11**

Use this parameter to set the undervoltage controller out of operation.

The function is necessary when

- the supply voltage changes, for example, between -15% and +10%, and
- the controlled process does not have the tolerance for the changes that the undervoltage controller and the overvoltage controller make to the output frequency of the drive.

The undervoltage controller decreases the output frequency of the drive

- to get energy from the motor to keep the DC-link voltage at a minimum level when the voltage is near the lowest permitted limit, and
- to make sure that the drive does not trip because of an undervoltage fault.

NOTICE

The drive can trip when the overvoltage and undervoltage controllers are disabled.

11.3.2.8 (ID 666) Energy Optimization

Location in the menu: **P3.1.2.12**

Use this parameter to enable the Energy Optimization function. To save energy and to lower the motor noise, the drive searches for the minimum motor current. Use this function, for example in fan and pump processes. Do not use the function with fast PID controlled processes.

11.3.2.9 (ID 659) Stator Voltage Adjust

Location in the menu: **P3.1.2.13**

Use this parameter to adjust the stator voltage in permanent magnet motors.

NOTICE

The identification run sets a value for this parameter automatically. We recommend the identification run, if it is possible. Make the identification run with the parameter P3.1.2.4.

It is possible to use this parameter only when the parameter P3.1.2.2 Motor Type has the value PM motor. If induction motor is selected as the motor type, the value is automatically set to 100%, and the value cannot be changed.

When changing the value of P3.1.2.2 (Motor type) to PM Motor, the parameters P3.1.4.2 (Field Weakening Point Frequency) and P3.1.4.3 (Voltage at Field Weakening Point) increase automatically to be equal with output voltage of the drive. The set U/f ratio does not change. This is done to prevent the operation of the PM motor in the field weakening area. The nominal voltage of the PM motor is much lower than the full output voltage of the drive.

The nominal voltage of the PM motor agrees to the back EMF voltage of the motor at nominal frequency. But in a different motor manufacturer, it can be equal to, for example, the stator voltage at nominal load.

Stator Voltage Adjust helps to adjust the U/f curve of the drive near the back EMF curve. It is not necessary to change the values of many U/f curve parameters.

The parameter P3.1.2.13 gives the output voltage of the drive in percentage of the nominal voltage of the motor at the nominal frequency of the motor. Adjust the U/f curve of the drive above the back EMF curve of the motor. The motor current increases the more the U/f curve is different from the back EMF curve.

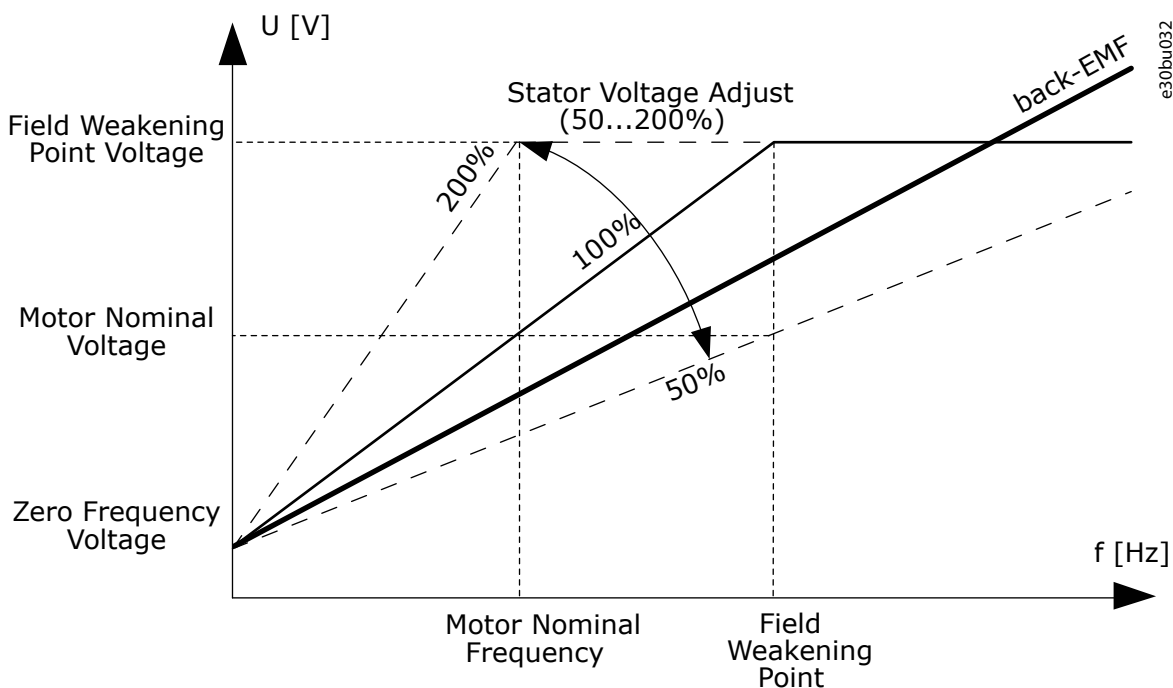

Illustration 36: The Stator Voltage Adjustment

11.3.2.10 (ID 662) Stator Resistance Voltage Drop

Location in the menu: **P3.1.2.15**

Use this parameter to set the motor stator phase-resistance value (in star-connection equivalent circuit). The resistance is essential for an accurate motor control.

The value is given as a percentage of voltage drop at nominal current.

NOTICE

The identification run sets a value for this parameter automatically. We recommend the identification run, if it is possible. Make the identification run with the parameter P3.1.2.4.

11.3.2.11 (ID 673) Stator Inductance Voltage Drop

Location in the menu: **P3.1.2.16**

Use this parameter to set the motor stator phase-inductance value (in star-connection equivalent circuit). The value is the transient inductance (for induction motors) or the line-to-neutral inductance (for permanent magnet and reluctance motors).

The value is given as a percentage of voltage drop at nominal current and nominal frequency.

NOTICE

The identification run sets a value for this parameter automatically. We recommend the identification run, if it is possible. Make the identification run with the parameter P3.1.2.4.

11.3.2.12 (ID 674) Motor BEM Voltage

Location in the menu: **P3.1.2.17**

Use this parameter to set the back electromotive force (back EMF) voltage of a permanent magnet motor. The value of this parameter is the motor terminal voltage when the motor current is zero.

The value is given as line-to-line RMS voltage at nominal operating frequency. Identification at standstill uses this parameter to set U/f curve in open loop control mode. The back EMF value that is identified in Identification with rotation overwrites the existing parameter value.

11.3.3 Motor Limits

11.3.3.1 (ID 107) Motor Current Limit

Location in the menu: **P3.1.3.1**

Use this parameter to set the maximum motor current from the AC drive. The range of values for the parameter is different for each enclosure size of the drive.

When the current limit is active, the drive output frequency decreases.

NOTICE

The Motor Current Limit is not an overcurrent trip limit.

11.3.3.2 (ID 1287) Motor Torque Limit

Location in the menu: **P3.1.3.2**

Use this parameter to set the maximum torque limit of the motoring side.

The range of values for the parameter is different for each enclosure size of the drive.

11.3.4 Open Loop Parameters

11.3.4.1 (ID 108) U/F Ratio

Location in the menu: **P3.1.4.1**

Use this parameter to set the type of the U/f curve between zero frequency and the field weakening point.

Selection number	Selection name	Description
0	Linear	The voltage of the motor changes linearly as a function of the output frequency. The voltage changes from the value of P3.1.4.6 (Zero Frequency Voltage) to the value of P3.1.4.3 (Voltage at Field Weakening Point) at a frequency set in P3.1.4.2 (Field Weakening Point Frequency). Use this default setting if a different setting is not necessary.
1	Squared	The voltage of the motor changes from the value of P3.1.4.6 (Zero Frequency Voltage) to the value of P3.1.4.2 (Field Weakening Point Frequency) at a squared curve. The motor operates undermagnetized below the field weakening point and produces less torque. Use the squared U/f ratio in applications where the torque demand is in relation to the square of the speed, for example in centrifugal fans and pumps.
2	Programmable	It is possible to program the U/f curve with 3 different points: the zero frequency voltage (P1), the mid-point voltage/ frequency (P2), and the field weakening point (P3). Use the programmable U/f curve at low frequencies if it is necessary to have more torque. Use the identification run (P3.1.2.4) to find the optimal settings automatically.

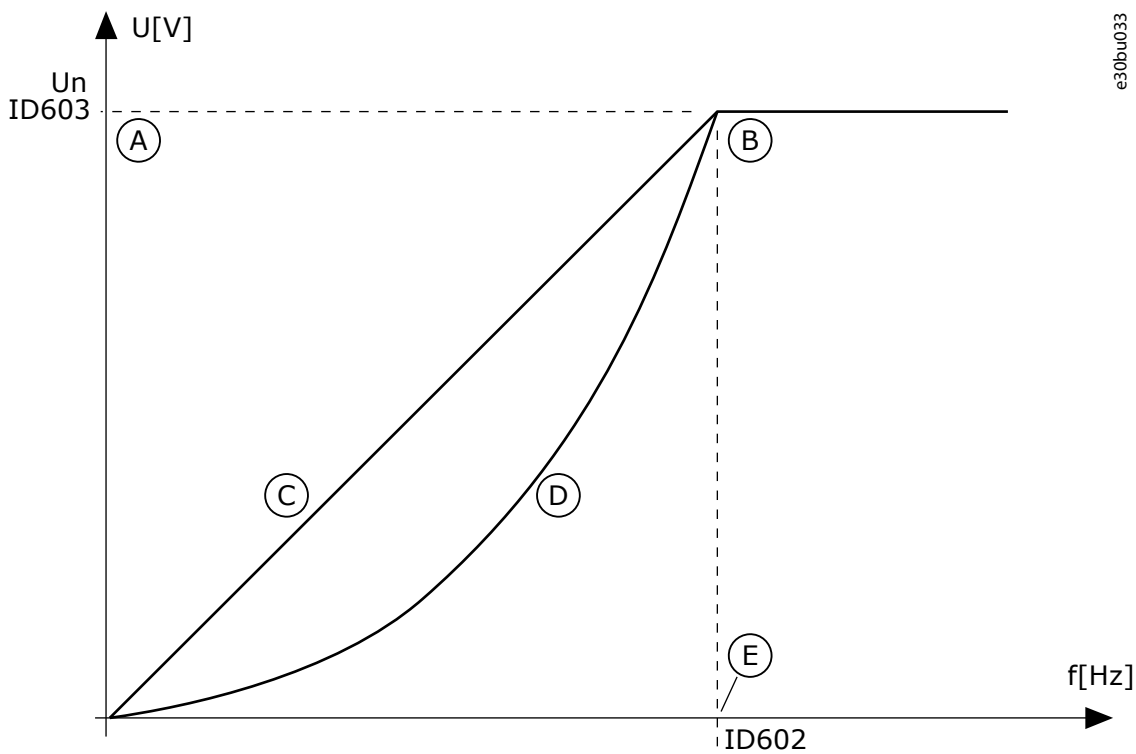

Illustration 37: Linear and Squared Change of the Motor Voltage

A	Default: Nominal voltage of the motor	D	Squared
B	Field weakening point	E	Default: Nominal frequency of the motor
C	Linear		

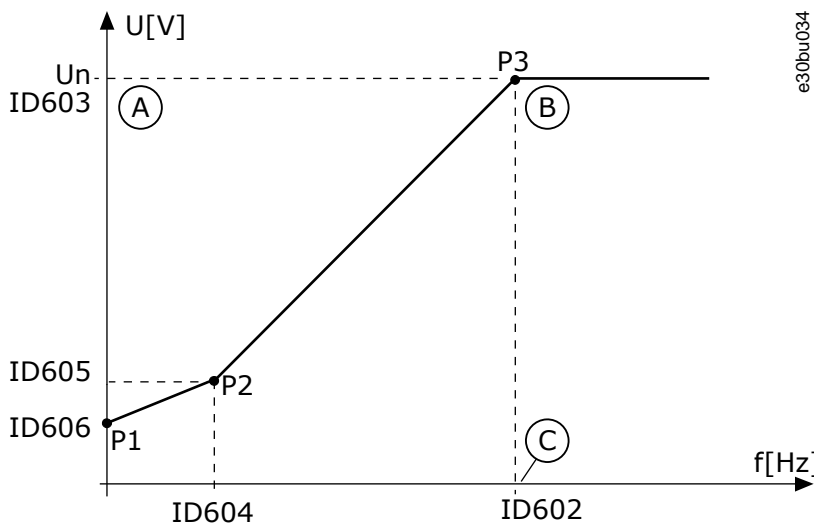

Illustration 38: The Programmable U/f Curve

A	Default: Nominal voltage of the motor	C	Default: Nominal frequency of the motor
B	Field weakening point		

When the parameter Motor Type has the value PM motor (Permanent Magnet Motor), this parameter is automatically set to the value Linear.

When the parameter Motor Type has the value Induction Motor, and when this parameter is changed, these parameters are set to their default values:

- P3.1.4.2 Field Weakening Point Frequency
- P3.1.4.3 Voltage at Field Weakening Point
- P3.1.4.4 U/f Midpoint Frequency
- P3.1.4.5 U/f Midpoint Voltage
- P3.1.4.6 Zero Frequency Voltage

11.3.4.2 (ID 602) Field Weakening Point Frequency

Location in the menu: **P3.1.4.2**

Use this parameter to set the output frequency at which the output voltage reaches the field weakening point voltage.

11.3.4.3 (ID 603) Voltage at Field Weakening Point

Location in the menu: **P3.1.4.3**

Use this parameter to set the voltage at the field weakening point as a percentage of the motor nominal voltage.

Above the frequency at the field weakening point, the output voltage stays at the set maximum value. Below the frequency at the field weakening point, the U/f curve parameters control the output voltage. See the U/f parameters P3.1.4.1, P3.1.4.4 and P3.1.4.5.

When setting the parameters P3.1.1.1 (Motor nominal voltage) and P3.1.1.2 (Motor nominal frequency), the parameters P3.1.4.2 and P3.1.4.3 automatically receive related values. To have different values for P3.1.4.2 and P3.1.4.3, change these parameters only after setting the parameters P3.1.1.1 and P3.1.1.2.

11.3.4.4 (ID 604) U/f Midpoint Frequency

Location in the menu: **P3.1.4.4**

Use this parameter to set the middle point frequency of the U/f curve.

NOTICE

This parameter gives the middle point frequency of the curve if the value of P3.1.4.1 is programmable.

11.3.4.5 (ID 605) U/f Midpoint Voltage

Location in the menu: **P3.1.4.5**

Use this parameter to set the middle point voltage of the U/f curve.

N O T I C E

This parameter gives the middle point voltage of the curve if the value of P3.1.4.1 is programmable.

11.3.4.6 (ID 606) Zero Frequency Voltage

Location in the menu: **P3.1.4.6**

Use this parameter to set the zero frequency voltage of the U/f curve. The default value for the parameter is different for each unit size.

11.3.4.7 (ID 1590) Flying Start Options

Location in the menu: **P3.1.4.7**

Use this parameter to set the flying start options. The parameter Flying Start Options has a checkbox selection of values. The bits can receive these values.

- Search the shaft frequency only from the same direction as the frequency reference
- Disable the AC scanning
- Use the frequency reference for an initial guess
- Disable the DC pulses
- Flux build with current control

The bit B0 controls the search direction. With the bit set to 0, the shaft frequency is searched in 2 directions, the positive and the negative. With the bit set to 1, the shaft frequency is searched only in the frequency reference direction. It prevents the shaft movements for the other direction.

The bit B1 controls the AC scanning that premagnetizes the motor. In the AC scanning, the system sweeps the frequency from the maximum towards zero frequency. The AC scanning stops when an adaptation to the shaft frequency occurs. To disable the AC scanning, set the bit B1 to 1. If the value of Motor Type is permanent magnet motor, the AC scanning is disabled automatically.

Use the bit B5 to disable the DC pulses. The primary function of the DC pulses is to premagnetize the motor and examine the rotation of the motor. If the DC pulses and the AC scanning are enabled, the slip frequency tells which procedure is applied. If the slip frequency is less than 2 Hz, or the motor type is PM motor, the DC pulses are disabled automatically.

The bit B7 controls the rotation direction of the injected high frequency signal, which is used in the flying start of synchronous reluctance machines. Signal injection is used to detect the frequency of the rotor. If the rotor is in a blind angle when the signal is injected, the rotor frequency is undetectable. Reversing the rotation direction of the injection signal solves this problem.

11.3.4.8 (ID 1610) Flying Start Scan Current

Location in the menu: **P3.1.4.8**

Use this parameter to set the flying start scan current as a percentage of the motor nominal current.

11.3.4.9 (ID 109) Start Boost

Location in the menu: **P3.1.4.9**

Use this parameter with a process that has a high starting torque because of friction.

Use the start boost only when starting the drive. The start boost is deactivated after 10 s or when the output frequency of the drive is more than half of the frequency of the field weakening point.

The voltage to the motor changes in relation to the necessary torque. It makes the motor give more torque at the start and when the motor operates at low frequencies.

The start boost affects a linear U/f curve. To get the best result, do the identification run and activate the programmable U/f curve.

11.3.5 I/f Start Function

With a PM motor, use the I/f Start function to start the motor with constant current control. A high power motor gives the best effect. With a high power motor, the resistance is low and it is not easy to change the U/f curve.

The I/f Start function can also give a sufficient torque for the motor at start up.

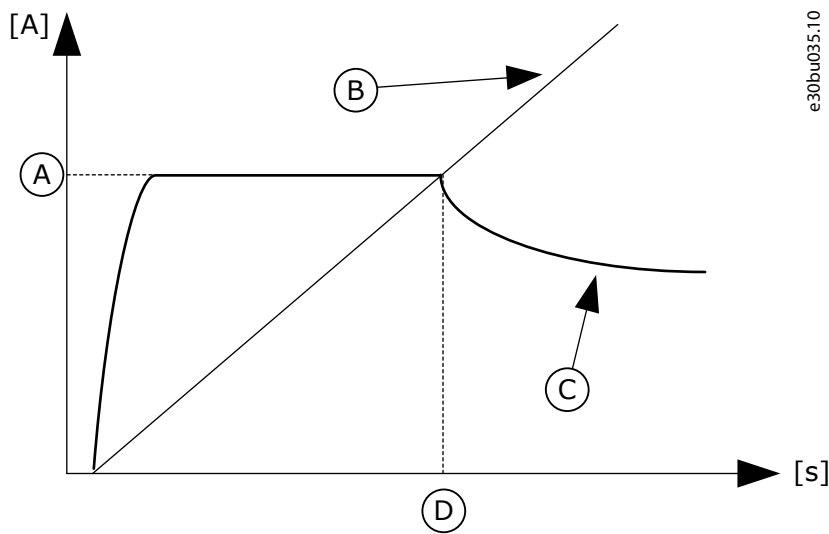

Illustration 39: The I/f Start Parameters

A	I/f Start Current	C	Motor Current
B	Output Frequency	D	I/f Start Frequency

11.3.5.1 (ID 534) I/f Start

Location in the menu: P3.1.4.12.1

Use this parameter to enable the I/f start function.

When the I/f start function is activated, the drive starts to operate in the current control mode. A constant current is led to the motor until the output frequency increases above the level that is set in P3.1.4.12.2. When the output frequency increases above I/f Start Frequency level, the operation mode changes back to the normal U/f control mode.

11.3.5.2 (ID 535) I/f Start Frequency

Location in the menu: P3.1.4.12.2

Use this parameter to set the output frequency limit below which the set I/f start current is fed to motor.

When the output frequency of the drive is below the limit of this parameter, I/f start function activates. When the output frequency is more than the limit, the drive operation mode changes back to the normal U/f control mode.

11.3.5.3 (ID 536) I/f Start Current

Location in the menu: P3.1.4.12.3

Use this parameter to set the current that is used when the I/f start function is enabled.

11.3.6 Torque Stabilator Function

11.3.6.1 (ID 1412) Torque Stabilator Gain

Location in the menu: P3.1.4.13.1

Use this parameter to set the gain of the torque stabilator in an open loop control operation.

11.3.6.2 (ID 1414) Torque Stabilator Gain at Field Weakening Point

Location in the menu: P3.1.4.13.2

Use this parameter to set the gain of the torque stabilator at field weakening point in an open loop control operation. The torque stabilizer stabilizes the possible oscillations in the estimated torque.

Two gains are used. TorqStabGainFWP is a constant gain at all the output frequencies. TorqStabGain changes linearly between the zero frequency and the field weakening point frequency. The full gain is at 0 Hz and the gain is zero at the field weakening point. The figure shows the gains as a function of output frequency.

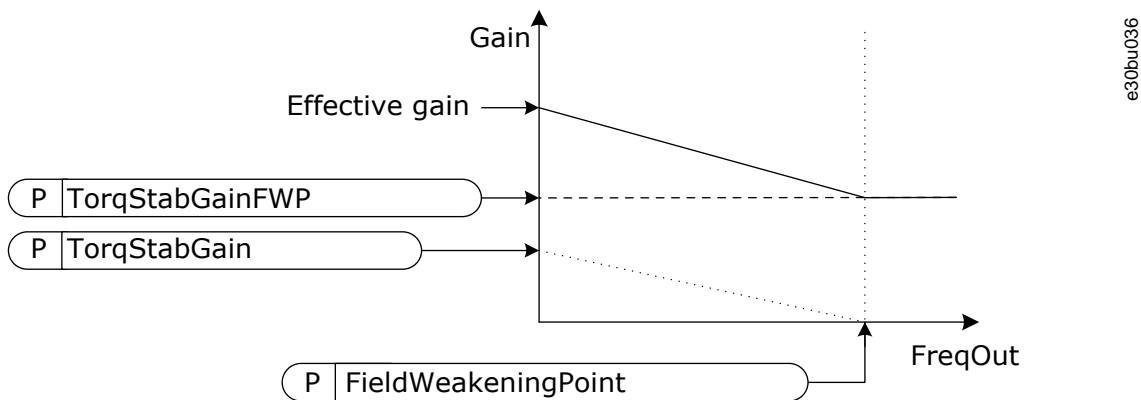

Illustration 40: The Torque Stabilizer Gain

11.3.6.3 (ID 1413) Torque Stabilizer Damping Time Constant

Location in the menu: **P3.1.4.13.3**

Use this parameter to set the damping time constant of the torque stabilizer.

11.3.6.4 (ID 1735) Torque Stabilizer Damping Time Constant for PM Motors

Location in the menu: **P3.1.4.13.4**

Use this parameter to set the damping time constant of the torque stabilizer for permanent magnet or reluctance motors.

11.3.6.5 (ID 15650) Torque Stabilizer Filter Time Constant

Location in the menu: **P3.1.4.13.5**

Use this parameter to set the lowpass filtering time constant of the torque stabilizer.

11.3.6.6 (ID 15651) Torque Stabilizer Filter Time Constant for PM Motors

Location in the menu: **P3.1.4.13.6**

Use this parameter to set the lowpass filtering time constant of the torque stabilizer for permanent magnet or reluctance motors.

11.4 Start/Stop Setup

11.4.1 Start and Stop Commands in Different Control Places

Start and stop commands must be given differently in each control place.

Remote Control Place (I/O A)

Use the parameters P3.5.1.1 (Control signal 1 A), P3.5.1.2 (Control signal 2 A) and P3.5.1.3 (Control signal 3 A) to select digital inputs. These digital inputs control the start, stop, and reverse commands. Then select a logic for these inputs with P3.2.6 I/O A Logic.

Remote Control Place (I/O B)

Use the parameters P3.5.1.4 (Control signal 1 B), P3.5.1.5 (Control signal 2 B) and P3.5.1.6 (Control signal 3 B) to select digital inputs. These digital inputs control the start, stop, and reverse commands. Then select a logic for these inputs with P3.2.7 I/O B Logic.

Local Control Place (Keypad)

The start and stop commands come from the keypad buttons. The direction of the rotation is set with parameter P3.3.1.9 Keypad direction.

Remote Control Place (Fieldbus)

Start, stop, and reverse commands come from the fieldbus.

11.4.2 (ID 172) Remote Control Place

Location in the menu: **P3.2.1**

Use this parameter to select the remote control place (start/stop). Use this parameter to change back to remote control from VACON® Live, for example if the control panel is broken.

11.4.3 (ID 211) Local/Remote

Location in the menu: **P3.2.2**

Use this parameter to switch between the local and remote control places. Local control place is always keypad control. The remote control place can be I/O or Fieldbus, depending on the 'Remote Control Place' parameter value.

11.4.4 (ID 114) Keypad Stop Button

Location in the menu: **P3.2.3**

Use this parameter to enable the keypad stop button. When this function is enabled, a press of keypad stop button always stops the drive (regardless of the control place). When this function is disabled, a press of keypad stop button stops the drive in local control only.

Selection number	Selection name	Description
0	Yes	The keypad stop button is always enabled.
1	No	Limited function of the keypad stop button.

11.4.5 (ID 505) Start Function

Location in the menu: **P3.2.4**

Use this parameter to select the type of the start function.

Selection number	Selection name	Description
0	Ramping	The drive accelerates from 0 frequency to frequency reference.
1	Flying start	The drive detects the actual speed of the motor and accelerates from that speed to frequency reference.

11.4.6 (ID 506) Stop Function

Location in the menu: **P3.2.5**

Use this parameter to select the type of the stop function.

Selection number	Selection name	Description
0	Coasting	The motor stops on its inertia. When the stop command is given, the control by the drive stops and the current from the drive goes to 0.
1	Ramp	After the stop command, the speed of the motor is decreased to zero speed according to the deceleration parameters.

N O T I C E

Ramp stop cannot be guaranteed in all situations. If ramp stop is selected and the net voltage changes over 20%, the voltage estimation fails. In such case, ramp stop is not possible.

11.4.7 (ID 300) I/O A Start/Stop Logic

Location in the menu: **P3.2.6**

Use this parameter to control the start and stop of the drive with the digital signals. The selections can include the word 'edge' to help preventing an accidental start.

An accidental start can occur, for example, in these conditions:

- When the power is connected.
- When the power is connected again after a power cut.
- After resetting a fault.
- After Run Enable stops the drive.
- When changing the control place to I/O control.

Before starting the motor, the Start/Stop contact must be opened.

In all the examples of the next pages, the stop mode is coasting. CS = Control signal.

e30bu037

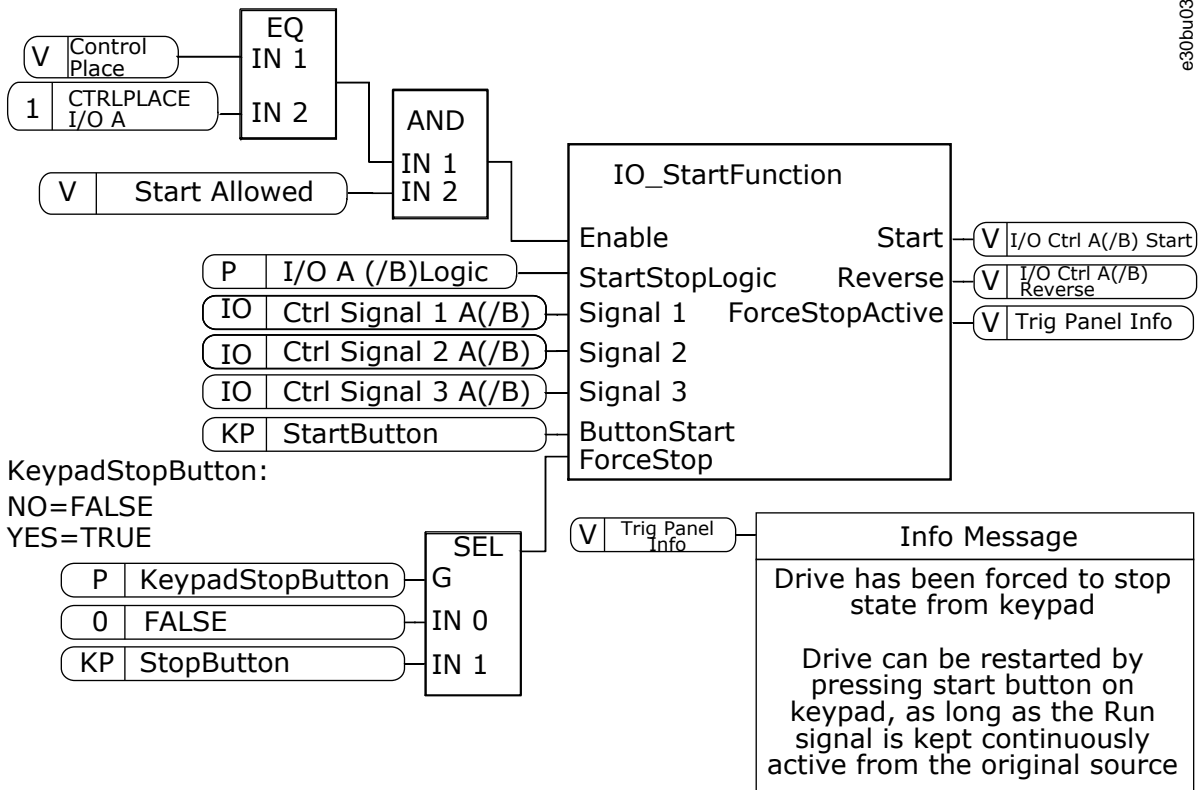

Illustration 41: The Block Diagram of the I/O A Start/Stop Logic

Selection = 0

Selection number	Selection name	Description
0	CS1 = Forward CS2 = Backward	The functions activate when the contacts are closed.

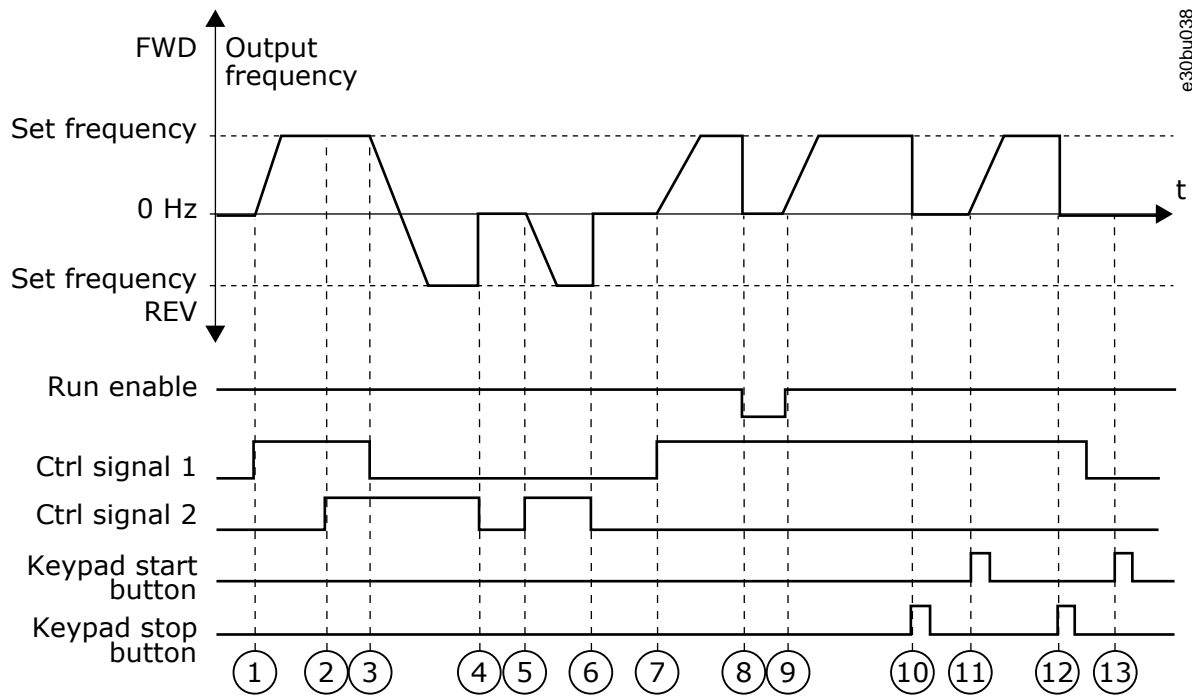

Illustration 42: I/O A Start/Stop Logic = 0

<p>1 Control signal (CS) 1 activates and causes the output frequency to increase. The motor operates forward.</p> <p>2 CS2 activates, but it does not affect the output frequency, because the direction that is set first has the highest priority.</p> <p>3 CS1 becomes inactive and causes the direction to start to change (FWD to REV), because CS2 is still active.</p> <p>4 CS2 becomes inactive and the frequency that is fed to the motor goes to 0.</p> <p>5 CS2 activates again and causes the motor to accelerate (REV) to the set frequency.</p> <p>6 CS2 becomes inactive and the frequency fed to the motor drops to 0.</p> <p>7 CS1 activates and the motor accelerates (FWD) to the set frequency.</p>	<p>8 The Run enable signal is set to OPEN, which causes the frequency to go to 0. Configure the Run enable signal with parameter P3.5.1.15.</p> <p>9 The Run enable signal is set to CLOSED, which causes the frequency to increase to the set frequency, because CS1 is still active.</p> <p>10 The STOP button on the keypad is pushed, and the frequency that is fed to the motor goes to 0. (This signal only works if the value of P3.2.3 Keypad Stop Button is Yes.)</p> <p>11 The drive starts because the START button on the keypad was pushed.</p> <p>12 The STOP button on the keypad is pushed again to stop the drive.</p> <p>13 The attempt to start the drive with the START button is not successful, because CS1 is inactive.</p>
---	--

Selection = 1

Selection number	Selection name	Description
1	CS1 = Forward (edge) CS2 = Inverted stop CS3 = Backward (edge)	For a 3-wire control (pulse control)

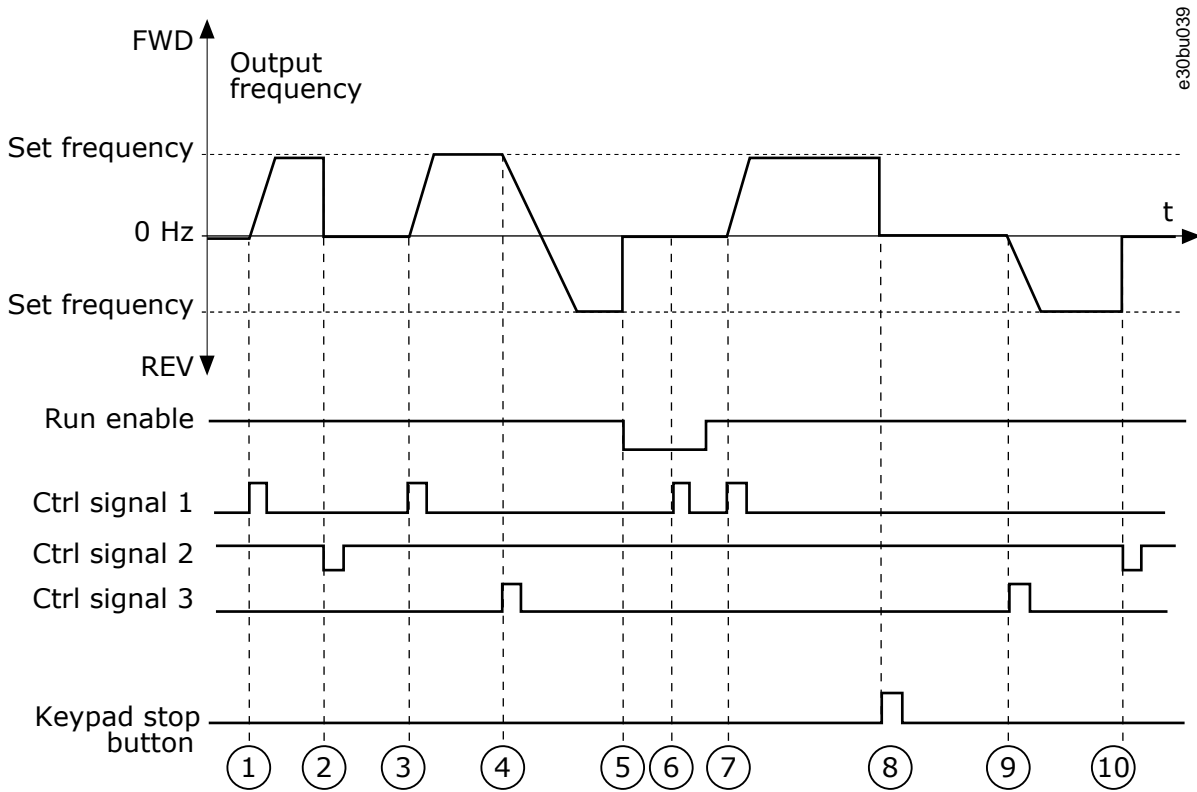

Illustration 43: I/O A Start/Stop Logic = 1

<p>1 Control signal (CS) 1 activates and causes the output frequency to increase. The motor operates forward.</p> <p>2 CS2 becomes inactive and causes the frequency to go to 0.</p> <p>3 CS1 activates and causes the output frequency to increase again. The motor operates forward.</p> <p>4 CS3 activates and causes the direction to start to change (FWD to REV).</p> <p>5 The Run enable signal is set to OPEN, which causes the frequency to go to 0. Configure the Run enable signal with parameter 3.5.1.15.</p>	<p>6 The start attempt with CS1 is not successful, because the Run enable signal is still OPEN.</p> <p>7 CS1 activates and the motor accelerates (FWD) to the set frequency, because the Run enable signal was set to CLOSED.</p> <p>8 The STOP button on the keypad is pushed, and the frequency that is fed to the motor goes to 0. (This signal only works if the value of P3.2.3 Keypad Stop Button is Yes.)</p> <p>9 CS3 activates and causes the motor to start and to operate in the reverse direction.</p> <p>10 CS2 becomes inactive and causes the frequency to go to 0.</p>
--	--

Selection = 2

Selection number	Selection name	Description
2	CS1 = Forward (edge) CS2 = Backward (edge)	Use this function to prevent an accidental start. Before starting the motor again, the start/stop contact must be opened.

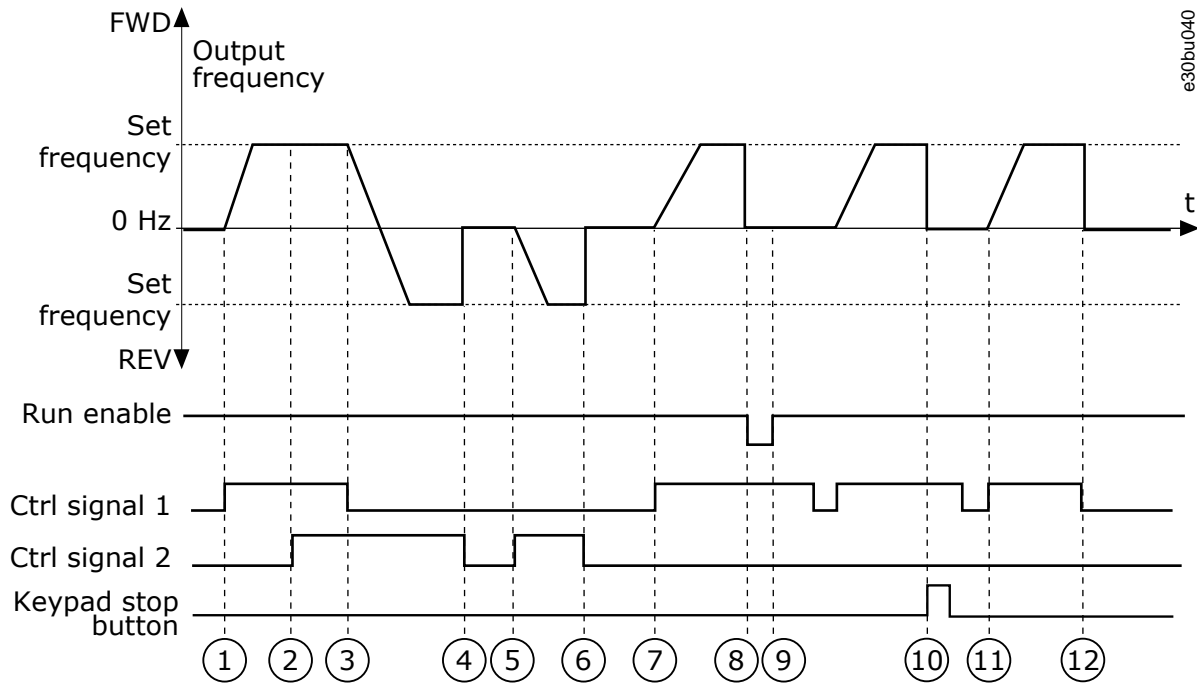

Illustration 44: I/O A Start/Stop Logic = 2

<p>1 Control signal (CS) 1 activates and causes the output frequency to increase. The motor operates forward.</p> <p>2 CS2 activates, but it does not affect the output frequency, because the direction that is set first has the highest priority.</p> <p>3 CS1 becomes inactive and causes the direction to start to change (FWD to REV), because CS2 is still active.</p> <p>4 CS2 becomes inactive and the frequency that is fed to the motor goes to 0.</p> <p>5 CS2 activates again and causes the motor to accelerate (REV) to the set frequency.</p> <p>6 CS2 becomes inactive and the frequency that is fed to the motor goes to 0.</p>	<p>7 CS1 activates and the motor accelerates (FWD) to the set frequency.</p> <p>8 The Run enable signal is set to OPEN, which causes the frequency to go to 0. Configure the Run enable signal with parameter P3.5.1.15.</p> <p>9 The Run enable signal is set to CLOSED, which does not affect, because a rising edge is necessary for the start, even if CS1 is active.</p> <p>10 The STOP button on the keypad is pushed and the frequency that is fed to the motor goes to 0. (This signal only works if the value of P3.2.3 Keypad Stop Button is Yes.)</p> <p>11 CS1 is opened and closed again, which causes the motor to start.</p> <p>12 CS1 becomes inactive and the frequency that is fed to the motor goes to 0.</p>
---	--

Selection = 3

Selection number	Selection name	Description
3	CS1 = Start CS2 = Reverse	

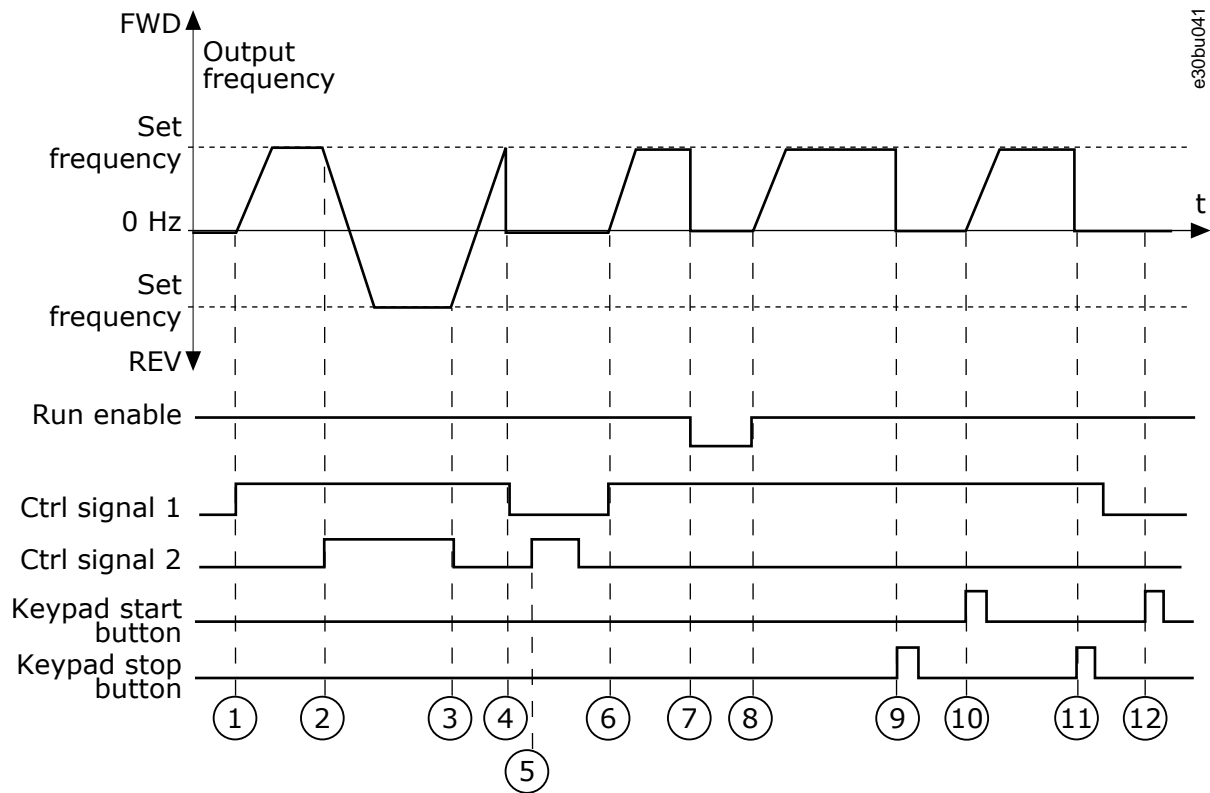

Illustration 45: I/O A Start/Stop Logic = 3

<p>1 Control signal (CS) 1 activates and causes the output frequency to increase. The motor operates forward.</p> <p>2 CS2 activates and causes the direction to start to change (FWD to REV).</p> <p>3 CS2 becomes inactive, which causes the direction to start to change (REV to FWD), because CS1 is still active.</p> <p>4 CS1 becomes inactive and the frequency goes to 0.</p> <p>5 CS2 activates, but the motor does not start because CS1 is inactive.</p> <p>6 CS1 activates and causes the output frequency to increase again. The motor operates forward because CS2 is inactive.</p>	<p>7 The Run enable signal is set to OPEN, which causes the frequency to go to 0. Configure the Run enable signal with parameter P3.5.1.15.</p> <p>8 The Run enable signal is set to CLOSED, which causes the frequency to increase to the set frequency, because CS1 is still active.</p> <p>9 The STOP button on the keypad is pushed and the frequency that is fed to the motor goes to 0. (This signal only works if the value of P3.2.3 Keypad Stop Button is Yes.)</p> <p>10 The drive starts because the START button on the keypad was pushed.</p> <p>11 The drive is stopped again with the STOP button on the keypad.</p> <p>12 The attempt to start the drive with the START button is not successful, because CS1 is inactive.</p>
---	--

Selection = 4

Selection number	Selection name	Description
4	CS1 = Start (edge) CS2 = Reverse	Use this function to prevent an accidental start. Before starting the motor again, the start/stop contact must be opened.

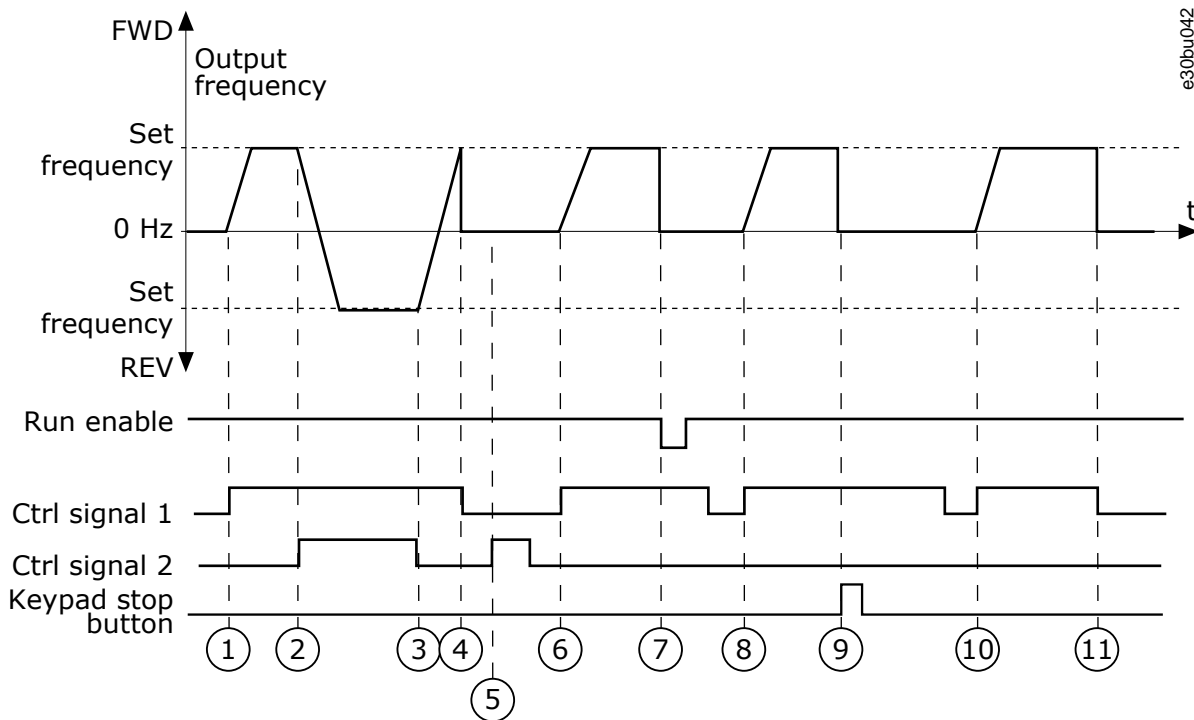

Illustration 46: I/O A Start/Stop Logic = 4

<p>1 Control signal (CS) 1 activates and causes the output frequency to increase. The motor operates forward because CS2 is inactive.</p> <p>2 CS2 activates, which causes the direction to start to change (FWD to REV).</p> <p>3 CS2 becomes inactive, which causes the direction to start to change (REV to FWD), because CS1 is still active.</p> <p>4 CS1 becomes inactive and the frequency goes to 0.</p> <p>5 CS2 activates, but the motor does not start because CS1 is inactive.</p> <p>6 CS1 activates and causes the output frequency to increase again. The motor operates forward, because CS2 is inactive.</p>	<p>7 The Run enable signal is set to OPEN, which causes the frequency to go to 0. Configure the Run enable signal with parameter P3.5.1.15.</p> <p>8 Before the drive can start, CS1 must be opened and closed again.</p> <p>9 The STOP button on the keypad is pushed and the frequency that is fed to the motor goes to 0. (This signal only works if the value of P3.2.3 Keypad Stop Button is Yes.)</p> <p>10 Before the drive can start, CS1 must be opened and closed CS1 again.</p> <p>11 CS1 becomes inactive and the frequency goes to 0.</p>
---	--

11.4.8 (ID 363) I/O B Start/Stop Logic

Location in the menu: **P3.2.7**

Use this parameter to control the start and stop of the drive with the digital signals. The selections can include the word 'edge' to help to prevent an accidental start. See P3.2.6 for more information.

11.4.9 (ID 889) Fieldbus Start Logic

Location in the menu: **P3.2.8**

Use this parameter to set the fieldbus start logic. The selections can include the word 'edge' to help to prevent an accidental start.

Selection number	Selection name	Description
0	A rising edge is necessary	
1	State	

11.4.10 (ID 524) Start Delay

Location in the menu: **P3.2.9**

Use this parameter to set the delay between the start command and the actual start of the drive.

11.4.11 (ID 181) Remote to Local Function

Location in the menu: **P3.2.10**

Use this parameter to set the selection of copy settings when going from Remote to Local (keypad) control.

Selection number	Selection name	Description
0	Keep Run	
1	Keep Run & Reference	
2	Stop	

11.4.12 (ID 15555) Restart Delay

Location in the menu: **P3.2.11**

Use this parameter to set the time delay during which the drive cannot be restarted after the drive has been stopped. The parameter is used in compressor applications.

Selection number	Selection name	Description
0	Restart delay not used	

11.5 References

11.5.1 Frequency Reference

It is possible to program the source of the frequency reference in all the control places, except the PC tool. When using PC, it always takes the frequency reference from the PC tool.

Remote Control Place (I/O A)

To set the source of the frequency reference for I/O A, use the parameter P3.3.1.5.

Remote Control Place (I/O B)

To set the source of the frequency reference for I/O B, use the parameter P3.3.1.6.

Local Control Place (Keypad)

If the default value keypad for the parameter P3.3.1.7 is used, the reference that was set for P3.3.1.8 Keypad Reference applies.

Remote Control Place (Fieldbus)

If the default value fieldbus for the parameter P3.3.1.10 is used, the frequency reference comes from fieldbus.

11.5.1.1 (ID 101) Minimum Frequency Reference

Location in the menu: **P3.3.1.1**

Use this parameter to set the minimum frequency reference.

11.5.1.2 (ID 102) Maximum Frequency Reference

Location in the menu: **P3.3.1.2**

Use this parameter to set the maximum frequency reference.

11.5.1.3 (ID 1285) Positive Frequency Reference Limit

Location in the menu: **P3.3.1.3**

Use this parameter to set the final frequency reference limit for the positive direction.

11.5.1.4 (ID 1286) Negative Frequency Reference Limit

Location in the menu: **P3.3.1.4**

Use this parameter to set the final frequency reference limit for the negative direction. Use this parameter for example to prevent the motor from running in the reverse direction.

11.5.1.5 (ID 117) I/O Control Reference A Selection

Location in the menu: **P3.3.1.5**

Use this parameter to select the reference source when the control place is I/O A. The application set with parameter 1.2 gives the default value.

11.5.1.6 (ID 131) I/O Control Reference B Selection

Location in the menu: **P3.3.1.6**

Use this parameter to select the reference source when the control place is I/O B. See P3.3.1.5 for more information. It is possible to force the I/O B control place to be active only with a digital input (P3.5.1.7).

11.5.1.7 (ID 121) Keypad Control Reference Selection

Location in the menu: **P3.3.1.7**

Use this parameter to select the reference source when the control place is keypad.

11.5.1.8 (ID 184) Keypad Reference

Location in the menu: **P3.3.1.8**

Use this parameter to adjust the frequency reference on the keypad.

11.5.1.9 (ID 123) Keypad Direction

Location in the menu: **P3.3.1.9**

Use this parameter to set the rotation direction of the motor when the control place is keypad.

11.5.2 Preset Frequencies

Use the Preset frequencies function in processes where more than 1 fixed frequency reference is necessary. There are 8 preset frequency references available. The selection of a preset frequency reference can be made with the digital input signals P3.3.3.10, P3.3.3.11, and P3.3.3.12.

11.5.2.1 (ID 182) Preset Frequency Mode

Location in the menu: **P3.3.3.1**

Use this parameter to set the logic of the digital input preset frequencies.

With this parameter, it is possible to set the logic which one of the preset frequencies is selected into use. There is a selection of 2 different logics. The number of preset speed digital inputs that are active defines the preset frequency.

Selection number	Selection name	Description
0	Binary coded	The mix of the inputs is binary coded. The different sets of active digital inputs determine the preset frequency.
1	Number (of inputs used)	The number of active inputs tells which preset frequency is used: 1, 2 or 3.

Value 0 selected

To set Preset Frequency 0 as reference, set the value 0 *Preset Frequency 0* for P3.3.1.5 (see [11.5.1.5 \(ID 117\) I/O Control Reference A Selection](#)).

To select a preset frequency 1–7, give digital inputs to P3.3.3.10 ([11.5.2.10 \(ID 419\) Preset Frequency Selection 0](#)), P3.3.3.11 ([11.5.2.11 \(ID 420\) Preset Frequency Selection 1](#)), and/or P3.3.3.12 ([11.5.2.12 \(ID 421\) Preset Frequency Selection 2](#)). The different sets of active digital inputs determine the preset frequency. For more data, see the following table. The values of the preset frequencies stay automatically between the minimum and maximum frequencies (P3.3.1.1 and P3.3.1.2).

Necessary step	Activated frequency
Select the value 0 for parameter P3.3.1.5.	Preset frequency 0

Table 128: The Selection of Preset Frequencies when Preset Frequency Mode is *Binary Coded*

Digital input signal Pre-set Freq Sel2 (P3.3.3.12)	Digital input signal Pre-set Freq Sel1 (P3.3.3.11)	Digital input signal Pre-set Freq Sel0 (P3.3.3.10)	Activated frequency reference
			Preset frequency 0 Only if Preset Freq 0 is set as frequency reference source with P3.3.3.1.5, P3.3.1.6, P3.3.1.7 or P3.3.1.10.
		Activated	Preset frequency 1
	Activated		Preset frequency 2
	Activated	Activated	Preset frequency 3
Activated			Preset frequency 4
Activated		Activated	Preset frequency 5
Activated	Activated		Preset frequency 6
Activated	Activated	Activated	Preset frequency 7

Value 1 selected

It is possible to use the Preset Frequencies 1–3 with different sets of active digital inputs. The number of active inputs tells which one is used.

Table 129: The Selection of Preset Frequencies when Preset Frequency Mode is *Number of Inputs*

Digital input signal Pre-set Freq Sel2 (P3.3.3.12)	Digital input signal Pre-set Freq Sel1 (P3.3.3.11)	Digital input signal Pre-set Freq Sel0 (P3.3.3.10)	Activated frequency reference
			Preset frequency 0 Only if Preset Freq 0 is set as frequency reference source with P3.3.3.1.5, P3.3.1.6, P3.3.1.7 or P3.3.1.10.
		Activated	Preset frequency 1
	Activated		Preset frequency 1
Activated			Preset frequency 1
	Activated	Activated	Preset frequency 2
Activated		Activated	Preset frequency 2
Activated	Activated		Preset frequency 2
Activated	Activated	Activated	Preset frequency 3

11.5.2.2 (ID 180) Preset Frequency 0

Location in the menu: **P3.3.3.2**

Use this parameter to set the preset frequency reference when the preset frequencies function is used. Select the preset frequencies with the digital input signals.

See more information in [11.5.2.1 \(ID 182\) Preset Frequency Mode](#).

11.5.2.3 (ID 105) Preset Frequency 1

Location in the menu: **P3.3.3.3**

Use this parameter to set the preset frequency reference when the preset frequencies function is used. Select the preset frequencies with the digital input signals.

See more information in [11.5.2.1 \(ID 182\) Preset Frequency Mode](#).

11.5.2.4 (ID 106) Preset Frequency 2

Location in the menu: **P3.3.3.4**

Use this parameter to set the preset frequency reference when the preset frequencies function is used. Select the preset frequencies with the digital input signals.

See more information in [11.5.2.1 \(ID 182\) Preset Frequency Mode](#).

11.5.2.5 (ID 126) Preset Frequency 3

Location in the menu: **P3.3.3.5**

Use this parameter to set the preset frequency reference when the preset frequencies function is used. Select the preset frequencies with the digital input signals.

See more information in [11.5.2.1 \(ID 182\) Preset Frequency Mode](#).

11.5.2.6 (ID 127) Preset Frequency 4

Location in the menu: **P3.3.3.6**

Use this parameter to set the preset frequency reference when the preset frequencies function is used. Select the preset frequencies with the digital input signals.

See more information in [11.5.2.1 \(ID 182\) Preset Frequency Mode](#).

11.5.2.7 (ID 128) Preset Frequency 5

Location in the menu: **P3.3.3.7**

Use this parameter to set the preset frequency reference when the preset frequencies function is used. Select the preset frequencies with the digital input signals.

See more information in [11.5.2.1 \(ID 182\) Preset Frequency Mode](#).

11.5.2.8 (ID 129) Preset Frequency 6

Location in the menu: **P3.3.3.8**

Use this parameter to set the preset frequency reference when the preset frequencies function is used. Select the preset frequencies with the digital input signals.

See more information in [11.5.2.1 \(ID 182\) Preset Frequency Mode](#).

11.5.2.9 (ID 130) Preset Frequency 7

Location in the menu: **P3.3.3.9**

Use this parameter to set the preset frequency reference when the preset frequencies function is used. Select the preset frequencies with the digital input signals.

See more information in [11.5.2.1 \(ID 182\) Preset Frequency Mode](#).

11.5.2.10 (ID 419) Preset Frequency Selection 0

Location in the menu: **P3.3.3.10**

Use this parameter to select the digital input signal that is used as a selector for the preset frequencies. This parameter is a binary selector for Preset speeds (0–7). See parameters P3.3.3.2 to P3.3.3.9.

11.5.2.11 (ID 420) Preset Frequency Selection 1

Location in the menu: **P3.3.3.11**

Use this parameter to select the digital input signal that is used as a selector for the preset frequencies. This parameter is a binary selector for Preset speeds (0–7). See parameters P3.3.3.2 to P3.3.3.9.

11.5.2.12 (ID 421) Preset Frequency Selection 2

Location in the menu: **P3.3.3.12**

Use this parameter to select the digital input signal that is used as a selector for the preset frequencies. This parameter is a binary selector for Preset speeds (0–7). See parameters P3.3.3.2 to P3.3.3.9.

To apply Preset frequencies 1–7, connect a digital input to these functions with the instructions in [11.7.1.2 Programming of Digital Inputs](#). See more data in [11.5.2.1 \(ID 182\) Preset Frequency Mode](#), and also in [Table 36](#), and [Table 44](#).

11.5.3 Motor Potentiometer Parameters

The frequency reference of the Motor Potentiometer is available in all the control places. It is possible to change the motor potentiometer reference only when the drive is in the run state.

NOTICE

If the output frequency is set slower than the Motor Potentiometer Ramp Time, the normal acceleration and deceleration times give limits to it.

11.5.3.1 (ID 418) Motor Potentiometer UP

Location in the menu: **P3.3.4.1**

Use this parameter to increase the output frequency with a digital input signal. With a motor potentiometer, it is possible to increase and decrease the output frequency. When a digital input is connected to parameter Motor Potentiometer UP, and the digital input signal is active, the output frequency rises. The motor potentiometer reference INCREASES until the contact is opened.

11.5.3.2 (ID 417) Motor Potentiometer DOWN

Location in the menu: **P3.3.4.2**

Use this parameter to decrease the output frequency with a digital input signal. With a motor potentiometer, it is possible to increase and decrease the output frequency. When a digital input is connected to parameter Motor Potentiometer DOWN, and the digital input signal is active, the output frequency falls. The motor potentiometer reference DECREASES until the contact is opened.

3 different parameters affect how the output frequency rises or falls when Motor Potentiometer UP or DOWN is active. These parameters are Motor Potentiometer Ramp Time (P3.3.4.3), Acceleration Time (P3.4.1.2), and Deceleration Time (P3.4.1.3).

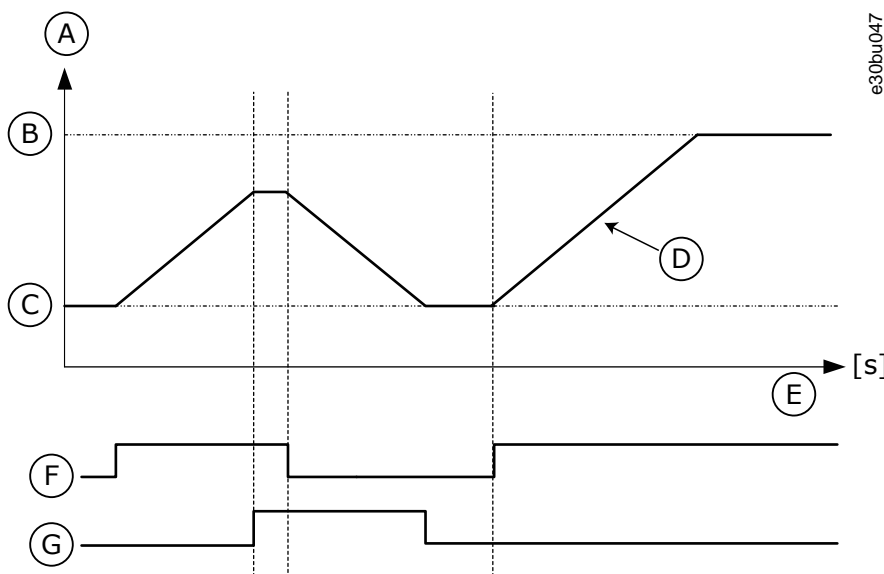

Illustration 47: The Motor Potentiometer Parameters

A	Frequency Reference	E	Time
B	Max Frequency	F	Motor potentiometer UP
C	Min Frequency	G	Motor potentiometer DOWN
D	Motor potentiometer ramp time		

11.5.3.3 (ID 331) Motor Potentiometer Ramp Time

Location in the menu: **P3.3.4.3**

Use this parameter to set the rate of change in the motor potentiometer reference when it is increased or decreased. The parameter value is entered as Hz/second.

11.5.3.4 (ID 367) Motor Potentiometer Reset

Location in the menu: **P3.3.4.4**

Use this parameter to set the logic for the resetting of the frequency reference of the motor potentiometer.

This parameter defines when the reference of the motor potentiometer is set to 0. There are 3 selections in the reset function: no reset, reset when the drive stops, or reset when the drive is powered down.

Selection number	Selection name	Description
0	No reset	The last motor potentiometer frequency reference is kept through the stop state and kept in memory when a power-down occurs.
1	Stop state	The motor potentiometer frequency reference is set to 0 when the drive goes to the stop state, or when the drive is powered down.
2	Powered down	The motor potentiometer frequency reference is set to 0 only when a power-down occurs.

11.5.4 Flushing Parameters

Use the Flushing function to override the normal control momentarily. Use the function to flush the pipeline or operate the pump manually at the preset constant speed, for example.

The Flushing function starts the drive at a selected reference without a start command no matter the control place.

11.5.4.1 (ID 530) Flushing Reference Activation

Location in the menu: **P3.3.6.1**

Use this parameter to select the digital input signal that activates the Flushing function. The flushing frequency reference is bidirectional and a reverse command does not affect the direction of the flushing reference.

N O T I C E

When the digital input is activated, the drive starts.

11.5.4.2 (ID 1239) Flushing Reference

Location in the menu: **P3.3.6.2**

Use this parameter to set the frequency reference of the drive when the Flushing function is used.

The reference is bidirectional and a reverse command does not affect the direction of the flushing reference. The reference for the forward direction is specified as a positive value and the reverse direction is specified as a negative value.

11.6 Ramps and Brakes Setup

11.6.1 Ramp 1

11.6.1.1 (ID 500) Ramp 1 Shape

Location in the menu: **P3.4.1.1**

Use this parameter to make the start and the end of the acceleration and deceleration ramps smoother.

With the parameters Ramp 1 Shape and Ramp 2 Shape, it is possible to make smoother the start and the end of the acceleration and deceleration ramps. The value is set to 0.0% gives a linear ramp shape. The acceleration and deceleration act immediately to the changes in the reference signal.

The value set between 1.0% and 100.0% gives an S-shaped acceleration or deceleration ramp. Use this function to reduce mechanical erosion of the parts and current spikes when the reference changes. The acceleration time can be modified with parameters P3.4.1.2 (Acceleration Time 1) and P3.4.1.3 (Deceleration Time 1).

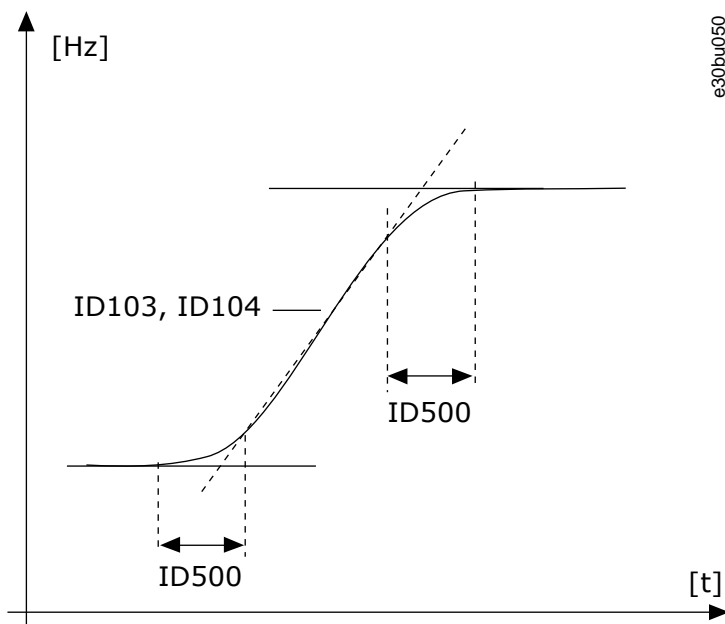

Illustration 48: The Acceleration/Deceleration Curve (S-shaped)

11.6.1.2 (ID 103) Acceleration Time 1

Location in the menu: **P3.4.1.2**

Use this parameter to set the time that is necessary for the output frequency to increase from zero frequency to maximum frequency.

11.6.1.3 (ID 104) Deceleration Time 1

Location in the menu: **P3.4.1.3**

Use this parameter to set the time that is necessary for the output frequency to decrease from maximum frequency to zero frequency.

11.6.2 Ramp 2

11.6.2.1 (ID 501) Ramp 2 Shape

Location in the menu: **P3.4.2.1**

Use this parameter to make the start and the end of the acceleration and deceleration ramps smoother.

With the parameters Ramp 1 Shape and Ramp 2 Shape, it is possible to make smoother the start and the end of the acceleration and deceleration ramps. The value set to 0.0% gives a linear ramp shape. The acceleration and deceleration act immediately to the changes in the reference signal.

The value set between 1.0% and 100.0% gives an S-shaped acceleration or deceleration ramp. Use this function to reduce mechanical erosion of the parts and current spikes when the reference changes. The acceleration time can be modified with parameters P3.4.2.2 (Acceleration Time 2) and P3.4.2.3 (Deceleration Time 2).

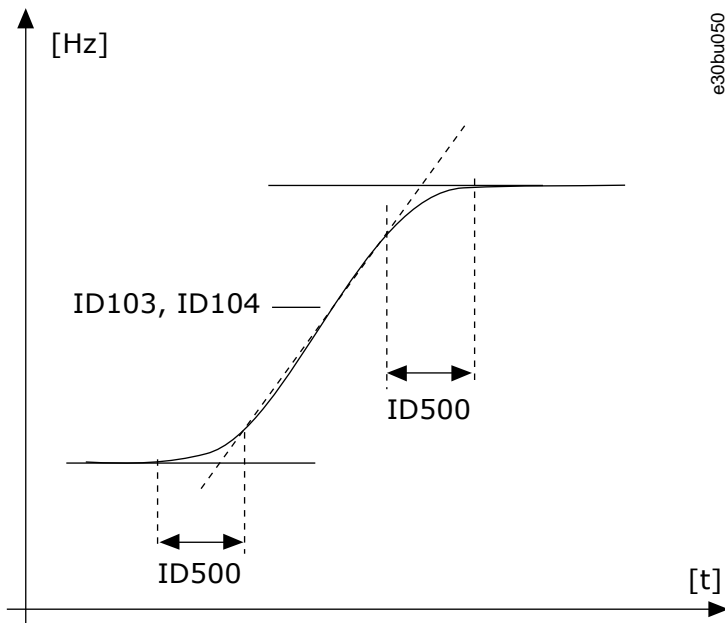

Illustration 49: The Acceleration/Deceleration Curve (S-shaped)

11.6.2.2 (ID 502) Acceleration Time 2

Location in the menu: **P3.4.2.2**

Use this parameter to set the time that is necessary for the output frequency to increase from zero frequency to maximum frequency.

11.6.2.3 (ID 503) Deceleration Time 2

Location in the menu: **P3.4.2.3**

Use this parameter to set the time that is necessary for the output frequency to decrease from maximum frequency to zero frequency.

11.6.2.4 (ID 408) Ramp 2 Selection

Location in the menu: **P3.4.2.4**

Use this parameter to select either ramp 1 or ramp 2.

Selection number	Selection name	Description
0	OPEN	Ramp 1 Shape, Acceleration Time 1, and Deceleration Time 1
1	CLOSED	Ramp 2 Shape, Acceleration Time 2, and Deceleration Time 2

11.6.2.5 (ID 533) Ramp 2 Threshold Frequency

Location in the menu: **P3.4.2.5**

Use this parameter to set the output frequency limit above which the Ramp 2 is used.

Use the function, for example, in applications for deep well pumps, where faster ramp times are necessary when the pump starts or stops (operates below the minimum frequency).

Second ramp times are activated when the output frequency of the drive goes above the limit specified by this parameter. To disable the function, set the value of the parameter to 0.

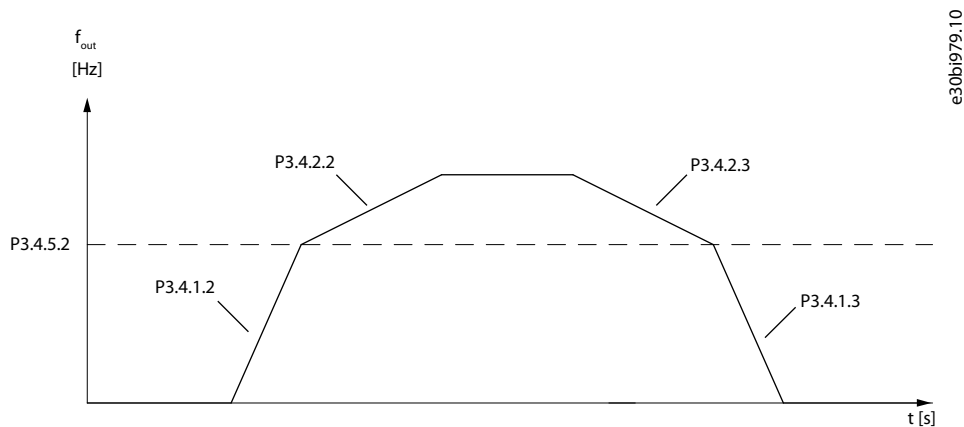

e30bi979.10

Illustration 50: Ramp 2 Activation when Output Frequency above the Threshold Level

P.3.4.5.2 Ramp threshold freq	P3.4.1.3 Dec. time 1
P3.4.1.2 Acc. time 1	P3.4.2.3 Dec. time 2
P3.4.2.2 Acc. time 2	

11.6.3 Start Magnetizing

11.6.3.1 (ID 517) Start Magnetizing Current

Location in the menu: **P3.4.3.1**

Use this parameter to set the DC current that is fed into the motor at the start. If the value of this parameter is set to 0, the Start Magnetizing function is disabled.

11.6.3.2 (ID 516) Start Magnetizing Time

Location in the menu: **P3.4.3.2**

Use this parameter to set the time during which the DC current is fed to the motor before the acceleration starts.

11.6.4 DC Brake

11.6.4.1 (ID 507) DC Brake Current

Location in the menu: **P3.4.4.1**

Use this parameter to set the current that is fed into the motor during DC braking. If the value of this parameter is set to 0, the DC brake function is disabled.

11.6.4.2 (ID 508) DC Braking Time at Stop

Location in the menu: **P3.4.4.2**

Use this parameter to set the braking is ON or OFF and to give the braking time when the motor stops. If the value of this parameter is set to 0, the DC brake function is disabled.

11.6.4.3 (ID 515) Frequency to Start DC Braking at Ramp Stop

Location in the menu: **P3.4.4.3**

Use this parameter to set the output frequency at which the DC-braking starts.

See [Illustration 63](#).

11.6.5 Flux Braking

11.6.5.1 (ID 520) Flux Braking

Location in the menu: **P3.4.5.1**

Use this parameter to enable Flux Braking. It is possible to use flux braking as an alternative to DC-braking. Flux braking increases the braking capacity in conditions where extra brake resistors are not necessary.

When braking is necessary, the system decreases the frequency and increases the flux in the motor. It increases the capacity of the motor to brake. The motor speed is controlled during braking.

NOTICE

Use the braking only intermittently. Flux braking converts energy into heat and can damage the motor.

11.6.5.2 (ID 519) Flux Braking Current

Location in the menu: **P3.4.5.2**

Use this parameter to set the current level for the flux braking.

11.7 I/O Configuration

11.7.1 Programming of Digital and Analog Inputs

11.7.1.1 General Information on the Programming

The programming of inputs of the AC drive is flexible. It is possible to use freely the available inputs of the standard and optional I/O for different functions.

It is possible to expand the available capacity of I/O with option boards. It is possible to install the option boards in the slots C, D, and E. For more data on the installation of option boards, see the Installation Guide.

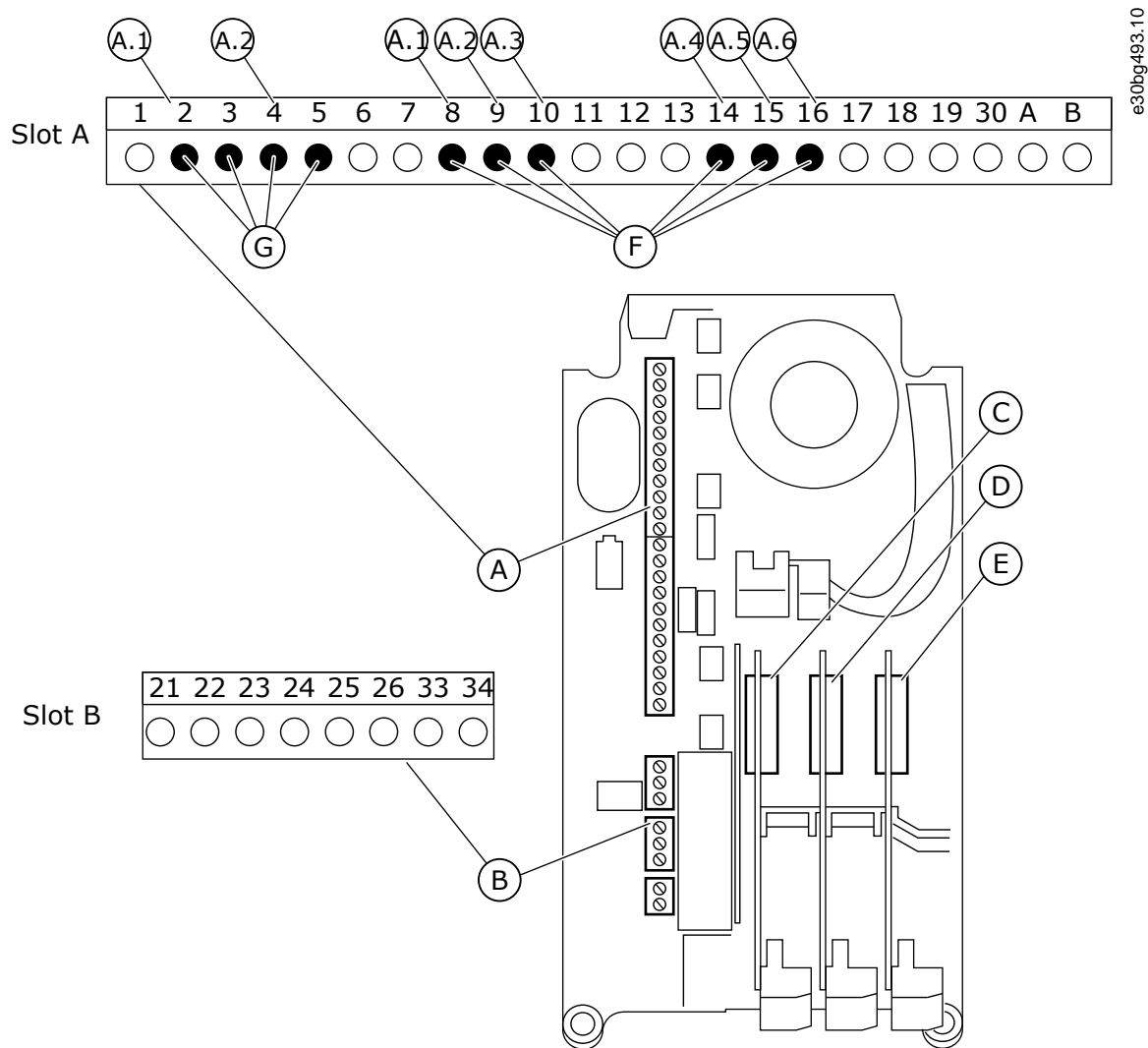

Illustration 51: The Option Board Slots and Programmable Inputs

A	Standard board slot A and its terminals	E	Option board slot E
B	Standard board slot B and its terminals	F	Programmable digital inputs (DI)
C	Option board slot C	G	Programmable analog inputs (AI)
D	Option board slot D		

11.7.1.2 Programming of Digital Inputs

Find the applicable functions for digital inputs as parameters in parameter group M3.5.1. To give a digital input to a function, set a value to the correct parameter. The list of applicable functions shows in [Table 44](#).

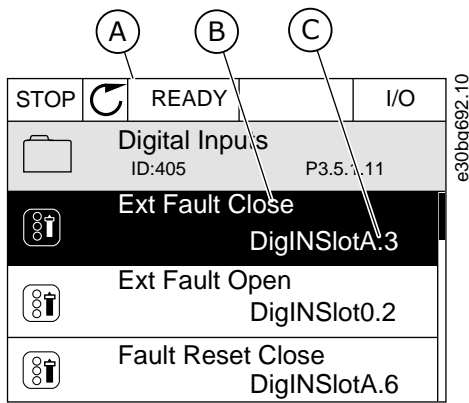

Illustration 52: The Digital Inputs Menu in the Graphical Display

A	The graphical display	C	The value of the parameter, that is, the set digital input
B	The name of the parameter, that is, the function		

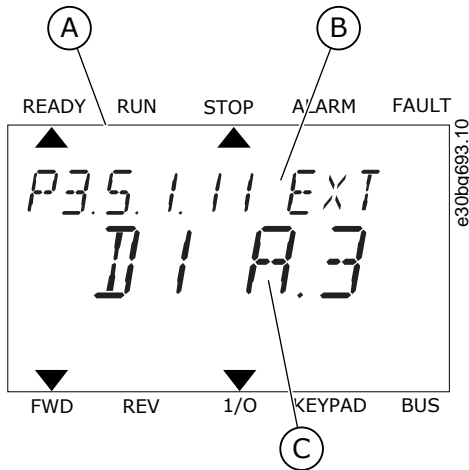

Illustration 53: The Digital Inputs Menu in the Text Display

A	The text display	C	The value of the parameter, that is, the set digital input
B	The name of the parameter, that is, the function		

Example

In the standard I/O board compilation, there are 6 digital inputs available: the slot A terminals 8, 9, 10, 14, 15 and 16.

Input type (graphical display)	Input type (text display)	Slot	Input #	Explanation
DigIN	dl	A	1	Digital input #1 (terminal 8) on a board in Slot A (standard I/O board).
DigIN	dl	A	2	Digital input #2 (terminal 9) on a board in Slot A (standard I/O board).
DigIN	dl	A	3	Digital input #3 (terminal 10) on a board in Slot A (standard I/O board).
DigIN	dl	A	4	Digital input #4 (terminal 14) on a board in Slot A (standard I/O board).
DigIN	dl	A	5	Digital input #5 (terminal 15) on a board in Slot A (standard I/O board).
DigIN	dl	A	6	Digital input #6 (terminal 16) on a board in Slot A (standard I/O board).

The function External Fault Close, the location of which is the menu M3.5.1, is parameter P3.5.1.11. It gets the default value DigIN SlotA.3 in the graphical display, and dI A.3 in the text display. After this selection, a digital signal to the digital input DI3 (terminal 10) controls External Fault Close.

Index	Parameter	Default	ID	Description
P3.5.1.11	External fault close	DigIN SlotA.3	405	OPEN = OK CLOSED = External fault

To change the input from DI3 to, for example, DI6 (terminal 16) on the standard I/O, obey these instructions.

11.7.1.3 Programming of Digital Inputs in the Graphical Display

Procedure

1. Select a parameter. To go into the Edit mode, push the arrow button Right.
2. In the Edit mode, the slot value DigIN SlotA is underlined and blinks. If there are more digital inputs available in the I/O, for example, because of option boards in slots C, D, or E, select them.

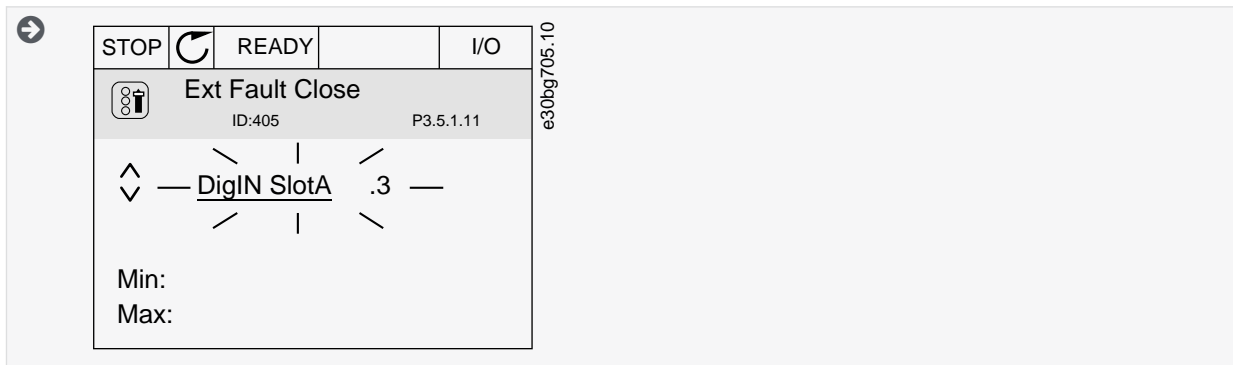

3. To activate the terminal 3, push the arrow button Right again.
4. To change the terminal to 6, push the arrow button Up 3 times. Accept the change with the [OK] button.

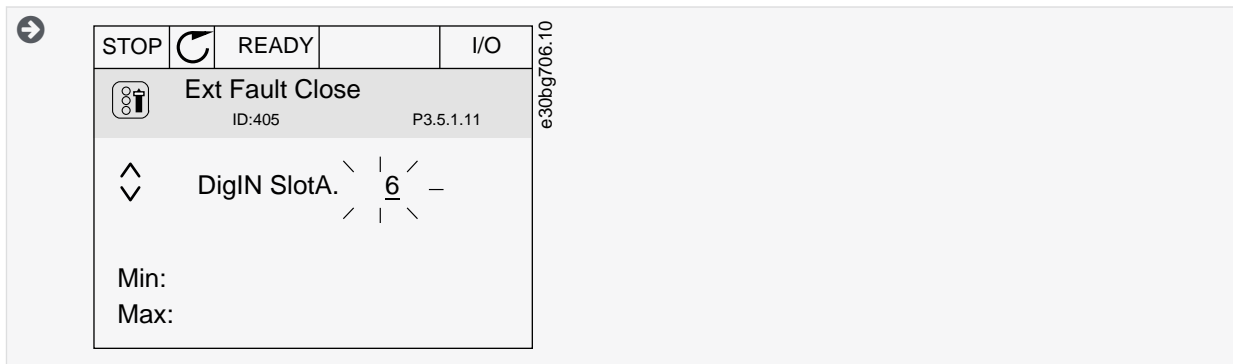

5. If the digital input DI6 was already used for some other function, a message shows on the display. Change one of these selections.

11.7.1.4 Programming of Digital Inputs in the Text Display

Procedure

1. Select a parameter. To go into the Edit mode, push the [OK] button.

- In the Edit mode, the letter D blinks. If there are more digital inputs available in the I/O, for example, because of option boards in slots C, D or E, select them.

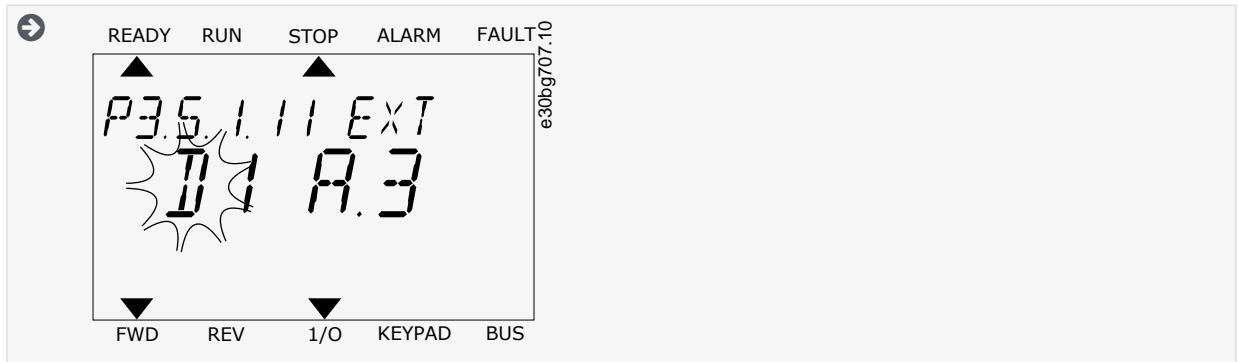

- To activate the terminal 3, push the arrow button Right again. The letter D stops blinking.
- To change the terminal to 6, push the arrow button Up 3 times. Accept the change with the [OK] button.

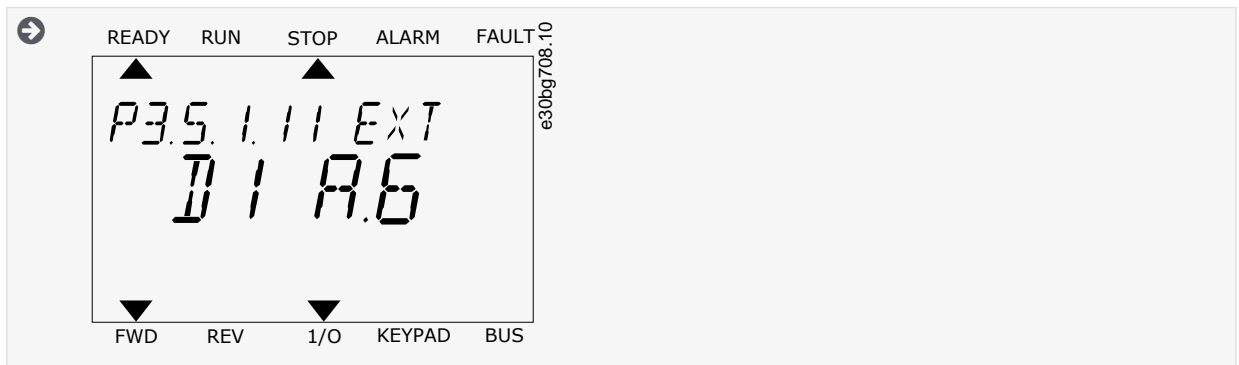

- If the digital input DI6 was already used for some other function, a message scrolls on the display. Change one of these selections.

It is also possible to give time channels to digital inputs. There is more data about it in [Table 79](#).

➔ After the steps, a digital signal to the digital input DI6 controls the function External Fault Close. The value of a function can be DigIN Slot0.1 (in the graphical display) or dl 0.1 (in the text display). In these conditions, a terminal was not given to the function, or the input was set to be always OPEN. It is the default value of most of parameters in the group M3.5.1. On the other hand, some inputs have the default value always CLOSED. Their value shows DigIN Slot0.2 in the graphical display and dl 0.2 in the text display.

11.7.1.5 Programming of Analog Inputs

It is possible to select the target input for the signal of the analog frequency reference from the available analog inputs.

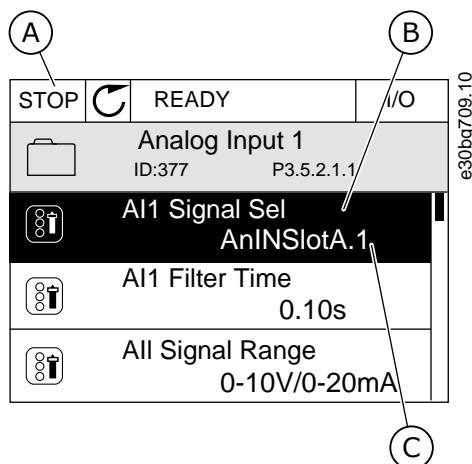

Illustration 54: The Analog Inputs Menu in the Graphical Display

A	The graphical display	C	The value of the parameter, that is, the set analog input
B	The name of the parameter		

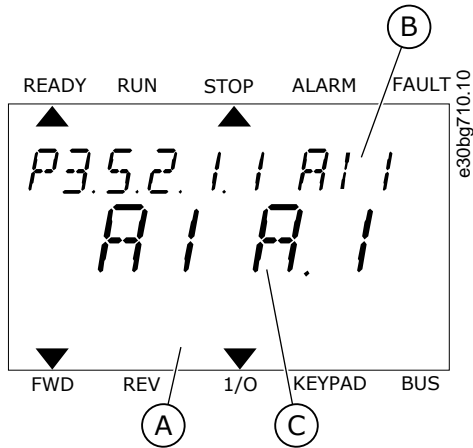

Illustration 55: The Analog Inputs Menu in the Text Display

A	The text display	C	The value of the parameter, that is, the set analog input
B	The name of the parameter		

Example

In the standard I/O board compilation, there are 2 analog inputs available: the slot A terminals 2/3 and 4/5.

Input type (graphical display)	Input type (text display)	Slot	Input #	Explanation
AnIN	AI	A	1	Analog input #1 (terminals 2/3) on a board in Slot A (standard I/O board).
AnIN	AI	A	2	Analog input #2 (terminals 4/5) on a board in Slot A (standard I/O board).

The location of the parameter P3.5.2.1.1 AI1 Signal Selection is the menu M3.5.2.1. The parameter gets the default value AnIN SlotA.1 in the graphical display or AI A.1 in the text display. The target input for the signal of the analog frequency reference AI1 is then the analog input in the terminals 2/3. Use the DIP switches to set the signal to be voltage or current. See the Installation manual for more data.

Index	Parameter	Default	ID	Description
P3.5.2.1.1	AI1 Signal Selection	AnIN SlotA.1	377	

To change the input from AI1 to, for example, the analog input on your option board in slot C, obey these instructions.

11.7.1.6 Programming of Analog Inputs in the Graphical Display

Procedure

1. To select the parameter, push the arrow button Right.
2. In the Edit mode, the value AnIN SlotA is underlined and blinks.

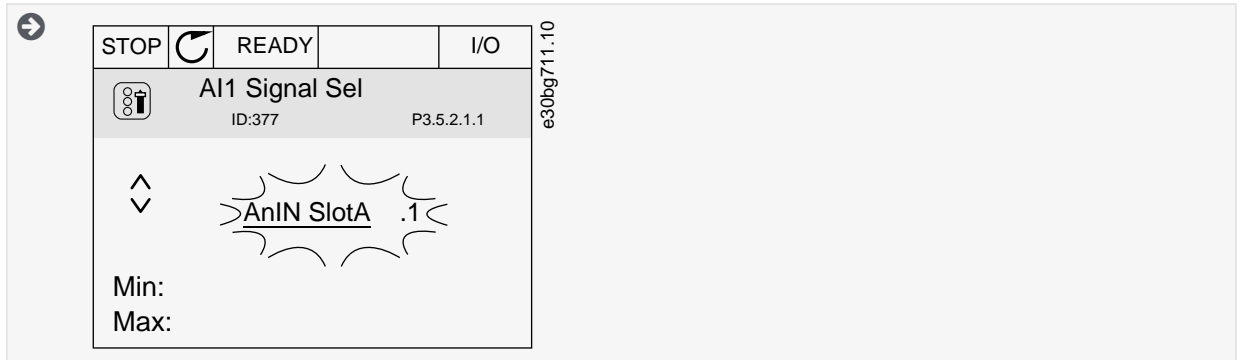

3. To change the value to AnIN SlotC, push the arrow button Up. Accept the change with the [OK] button.

11.7.1.7 Programming of Analog Inputs in the Text Display

Procedure

1. To select the parameter, push the [OK] button.
2. In the Edit mode, the letter A blinks.

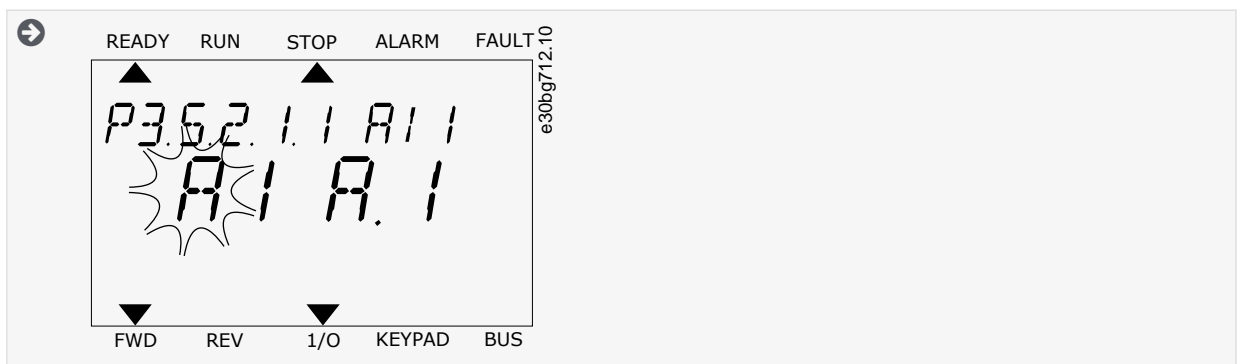

3. To change the value to C, push the arrow button Up. Accept the change with the [OK] button.

11.7.2 Descriptions of Signal Sources

Table 130: Descriptions of Signal Sources

Source	Function
Slot0.#	<p>Digital inputs: Use this function to set a digital signal to be in a constant OPEN or CLOSED state. The manufacturer set some signals so that they are always in the CLOSED state, for example parameter P3.5.1.15 (Run Enable). The Run Enable signal is always on if it is not changed. # = 1: Always OPEN # = 2–10: Always CLOSED</p> <p>Analog inputs (used for testing purposes): # = 1: Analog input = 0% of the signal strength # = 2: Analog input = 20% of the signal strength # = 3: Analog input = 30% of the signal strength, and so on # = 10: Analog input = 100% of the signal strength</p>
SlotA.#	Number (#) agrees to a digital input in slot A.
SlotB.#	Number (#) agrees to a digital input in slot B.

Source	Function
SlotC.#	Number (#) agrees to a digital input in slot C.
SlotD.#	Number (#) agrees to a digital input in slot D.
SlotE.#	Number (#) agrees to a digital input in slot E.
TimeChannel.#	1=Time Channel1, 2=Time Channel2, 3=Time Channel3
FieldbusCW.#	Number (#) refers to a control word bit number.
FieldbusPD.#	Number (#) refers to the process data 1 bit number.

11.7.3 Default Functions of Programmable Inputs

Table 131: Default Functions of the Programmable Digital and Analog Inputs

Input	Terminal(s)	Reference	Function	Parameter index
DI1	8	A.1	Control Signal 1 A	P3.5.1.1
DI2	9	A.2	Control Signal 2 A	P3.5.1.2
DI3	10	A.3	External Fault Close	P3.5.1.11
DI4	14	A.4	Preset Frequency Selection 0	P3.5.1.21
DI5	15	A.5	Preset Frequency Selection 1	P3.5.1.22
DI6	16	A.6	Fault Reset Close	P3.5.1.13
AI1	2/3	A.1	AI1 Signal Selection	P3.5.2.1.1
AI2	4/5	A.2	AI2 Signal Selection	P3.5.2.2.1

11.7.4 Digital Inputs

The parameters are functions that can be connected to a digital input terminal. The text DigIn Slot A.2 means the second input on the slot A. It is also possible to connect the functions to time channels. The time channels work as terminals.

It is possible to monitor the statuses of the digital inputs and the digital outputs in the Multimonitoring view.

11.7.4.1 (ID 403) Control Signal 1 A

Location in the menu: **P3.5.1.1**

Use this parameter to select the digital input signal (Control Signal 1) that starts and stops the drive when the control place is I/O A (FWD).

11.7.4.2 (ID 404) Control Signal 2 A

Location in the menu: **P3.5.1.2**

Use this parameter to select the digital input signal (Control Signal 2) that starts and stops the drive when the control place is I/O A (REV).

11.7.4.3 (ID 434) Control Signal 3 A

Location in the menu: **P3.5.1.3**

Use this parameter to select the digital input signal (Control Signal 3) that starts and stops the drive when the control place is I/O A.

11.7.4.4 (ID 423) Control Signal 1 B

Location in the menu: **P3.5.1.4**

Use this parameter to select the digital input signal (Control Signal 1) that starts and stops the drive when the control place is I/O B.

11.7.4.5 (ID 424) Control Signal 2 B

Location in the menu: **P3.5.1.5**

Use this parameter to select the digital input signal (Control Signal 2) that starts and stops the drive when the control place is I/O B.

11.7.4.6 (ID 435) Control Signal 3 B

Location in the menu: **P3.5.1.6**

Use this parameter to select the digital input signal (Control Signal 3) that starts and stops the drive when the control place is I/O B.

11.7.4.7 (ID 425) I/O B Control Force

Location in the menu: **P3.5.1.7**

Use this parameter to select the digital input signal that switches the control place from I/O A to I/O B.

11.7.4.8 (ID 343) I/O B Reference Force

Location in the menu: **P3.5.1.8**

Use this parameter to select the digital input signal that switches the frequency reference source from I/O A to I/O B.

11.7.4.9 (ID 411) Fieldbus Control Force

Location in the menu: **P3.5.1.9**

Use this parameter to select the digital input signal that switches the control place and the frequency reference source to Fieldbus (from I/O A, I/O B or Local control).

11.7.4.10 (ID 410) Keypad Control Force

Location in the menu: **P3.5.1.10**

Use this parameter to select the digital input signal that switches the control place and the frequency reference source to Keypad (from any control place).

11.7.4.11 (ID 405) External Fault Close

Location in the menu: **P3.5.1.11**

Use this parameter to select the digital input signal that activates an external fault.

11.7.4.12 (ID 406) External Fault Open

Location in the menu: **P3.5.1.12**

Use this parameter to select the digital input signal that activates an external fault.

11.7.4.13 (ID 414) Fault Reset Close

Location in the menu: **P3.5.1.13**

Use this parameter to select the digital input signal that resets all active faults. Active faults are reset when the state of the digital input changes from open to closed (rising edge).

11.7.4.14 (ID 213) Fault Reset Open

Location in the menu: **P3.5.1.14**

Use this parameter to select the digital input signal that resets all active faults. Active faults are reset when the state of the digital input changes from closed to open (falling edge).

11.7.4.15 (ID 407) Run Enable

Location in the menu: **P3.5.1.15**

Use this parameter to select the digital input signal that sets the drive to Ready state. When the contact is OPEN, the start of the motor is disabled. When the contact is CLOSED, the start of the motor is enabled.

The state of the drive remains in 'Not Ready' if the state of this signal is 'opened'. If the Run Enable signal is used for stopping the drive, the drive will always coast to stop regardless of the selection in parameter P3.2.5 Stop Function.

11.7.4.16 (ID 1041) Run Interlock 1

Location in the menu: **P3.5.1.16**

Use this parameter to select the digital input signal that prevents to start the drive. The drive can be ready but start is not possible when the state of the interlock signal is 'open' (damper interlock).

11.7.4.17 (ID 1042) Run Interlock 2

Location in the menu: **P3.5.1.17**

Use this parameter to select the digital input signal that prevents starting the drive. The drive can be ready but start is not possible when the state of the interlock signal is 'open' (damper interlock).

If an interlock is active, the drive cannot start.

It is possible to use this function to prevent the start of the drive when the damper is closed. If an interlock is activated during the operation of the drive, the drive stops.

11.7.4.18 (ID 1044) Motor Preheat ON

Location in the menu: **P3.5.1.18**

Use this parameter to select the digital input signal that activates Motor Preheat function. The Motor Preheat function feeds DC-current to the motor when the drive is in the stop state.

11.7.4.19 (ID 408) Ramp 2 Selection

Location in the menu: **P3.5.1.19**

Use this parameter to select the digital input signal that selects the ramp time to be used.

11.7.4.20 (ID 415) Acc/Dec Prohibit

Location in the menu: **P3.5.1.20**

Use this parameter to select the digital input signal that prevents the acceleration and the deceleration of the drive. No acceleration or deceleration is possible until the contact is open.

11.7.4.21 (ID 419) Preset Frequency Selection 0

Location in the menu: **P3.5.1.21**

Use this parameter to set the digital input signal that selects the preset frequencies.

11.7.4.22 (ID 420) Preset Frequency Selection 1

Location in the menu: **P3.5.1.22**

Use this parameter to set the digital input signal that selects the preset frequencies.

11.7.4.23 (ID 421) Preset Frequency Selection 2

Location in the menu: **P3.5.1.23**

Use this parameter to set the digital input signal that selects the preset frequencies.

11.7.4.24 (ID 418) Motor Potentiometer Up

Location in the menu: **P3.5.1.24**

Use this parameter to increase the output frequency with a digital input signal. The motor potentiometer reference INCREASES until the contact is open.

11.7.4.25 (ID 417) Motor Potentiometer Down

Location in the menu: **P3.5.1.25**

Use this parameter to decrease the output frequency with a digital input signal. The motor potentiometer reference DECREASES until the contact is open.

11.7.4.26 (ID 1213) Quick Stop Activation

Location in the menu: **P3.5.1.26**

Use this parameter to select the digital input signal that activates a Quick Stop function. The Quick Stop function stops the drive regardless of the control place or the state of the control signals.

11.7.4.27 (ID 447) Timer 1

Location in the menu: **P3.5.1.27**

Use this parameter to select the digital input signal that starts the timer. The timer starts when this signal is deactivated (falling edge). The output is deactivated when the time defined in the duration parameter has elapsed.

11.7.4.28 (ID 448) Timer 2

Location in the menu: **P3.5.1.28**

Use this parameter to select the digital input signal that starts the timer. The timer starts when this signal is deactivated (falling edge). The output is deactivated when the time defined in the duration parameter has elapsed.

11.7.4.29 (ID 449) Timer 3

Location in the menu: **P3.5.1.29**

Use this parameter to select the digital input signal that starts the timer. The timer starts when this signal is deactivated (falling edge). The output is deactivated when the time defined in the duration parameter has elapsed.

11.7.4.30 (ID 1046) PID Setpoint Boost

Location in the menu: **P3.5.1.30**

Use this parameter to select the digital input signal that activates the boost for the PID setpoint value. The timer starts when this signal is deactivated (falling edge). The output is deactivated when the time defined in the duration parameter has elapsed.

11.7.4.31 (ID 1047) PID Setpoint Selection

Location in the menu: **P3.5.1.31**

Use this parameter to set the digital input signal that selects the PID setpoint value to be used.

11.7.4.32 (ID 1049) External PID Start Signal

Location in the menu: **P3.5.1.32**

Use this parameter to select the digital input signal that starts and stops the external PID controller.

NOTICE

This parameter has no effect if the external PID controller is not enabled in Group 3.14.

11.7.4.33 (ID 1048) External PID Setpoint Selection

Location in the menu: **P3.5.1.33**

Use this parameter to set the digital input signal that selects the PID setpoint value to be used.

11.7.4.34 (ID 490) Reset Maintenance Counter

Location in the menu: **P3.5.1.34**

Use this parameter to select the digital input that reset the value of the Maintenance Counter.

11.7.4.35 (ID 530) Flushing Reference Activation

Location in the menu: **P3.5.1.36**

Use this parameter to select the digital input signal that activates the Flushing function. The flushing frequency reference is bidirectional and a reverse command does not affect the direction of the flushing reference.

NOTICE

If the input is activated, the drive starts.

11.7.4.36 (ID 1596) Fire Mode Activation OPEN

Location in the menu: **P3.5.1.38**

Use this parameter to select the digital input signal that activates the Fire Mode function. This parameter activates the Fire Mode if it is enabled with a correct password.

11.7.4.37 (ID 1619) Fire Mode Activation CLOSE

Location in the menu: **P3.5.1.39**

Use this parameter to select the digital input signal that activates the Fire Mode function. This parameter activates the Fire Mode if it is enabled with a correct password.

11.7.4.38 (ID 1618) Fire Mode Reverse

Location in the menu: **P3.5.1.40**

Use this parameter to select the digital input signal that gives a command for reverse rotation direction during the Fire Mode. This function has no effect in normal operation.

11.7.4.39 (ID 1715) Auto-Cleaning Activation

Location in the menu: **P3.5.1.41**

Use this parameter to select the digital input signal that starts the Auto-cleaning. The Auto-cleaning stops if the activation signal is removed before the process is complete.

NOTICE

If the input is activated, the drive starts.

11.7.4.40 (ID 426) Pump 1 Interlock

Location in the menu: **P3.5.1.42**

Use this parameter to select the digital input signal that is used as interlock signal for the Multi-pump system. The selection of the application with parameter P1.2 Application gives the default value.

11.7.4.41 (ID 427) Pump 2 Interlock

Location in the menu: **P3.5.1.43**

Use this parameter to select the digital input signal that is used as interlock signal for the Multi-pump system. The selection of the application with parameter P1.2 Application gives the default value.

11.7.4.42 (ID 428) Pump 3 Interlock

Location in the menu: **P3.5.1.44**

Use this parameter to select the digital input signal that is used as interlock signal for the Multi-pump system. The selection of the application with parameter P1.2 Application gives the default value.

11.7.4.43 (ID 429) Pump 4 Interlock

Location in the menu: **P3.5.1.45**

Use this parameter to select the digital input signal that is used as interlock signal for the Multi-pump system. The selection of the application with parameter P1.2 Application gives the default value.

11.7.4.44 (ID 430) Pump 5 Interlock

Location in the menu: **P3.5.1.46**

Use this parameter to select the digital input signal that is used as interlock signal for the Multi-pump system. The selection of the application with parameter P1.2 Application gives the default value.

11.7.4.45 (ID 486) Pump 6 Interlock

Location in the menu: **P3.5.1.47**

Use this parameter to select the digital input signal that is used as interlock signal for the Multi-pump system. The selection of the application with parameter P1.2 Application gives the default value.

11.7.4.46 (ID 487) Pump 7 Interlock

Location in the menu: **P3.5.1.48**

Use this parameter to select the digital input signal that is used as interlock signal for the Multi-pump system. The selection of the application with parameter P1.2 Application gives the default value.

11.7.4.47 (ID 488) Pump 8 Interlock

Location in the menu: **P3.5.1.49**

Use this parameter to select the digital input signal that is used as interlock signal for the Multi-pump system. The selection of the application with parameter P1.2 Application gives the default value.

11.7.4.48 (ID 1053) Reset kWh Trip Counter

Location in the menu: **P3.5.1.52**

Use this parameter to select the digital input signal that resets the kWh Trip Counter.

11.7.4.49 (ID 496) Parameter Set 1/2 Selection

Location in the menu: **P3.5.1.53**

Use this parameter to set the digital input that selects the parameter set to be used. This function is enabled if any other slot than 'DigIN Slot0' is selected to this parameter. The parameter set selection is allowed only when the drive is stopped.

- Contact Open = Parameter Set 1 is loaded as the active set
- Contact Closed = Parameter Set 2 is loaded as the active set

Parameter values are stored to Set 1 and Set 2 by parameters B6.5.4 Save to Set 1 and B6.5.4 Save to Set 2. These parameters can be used either from keypad or VACON® Live PC tool.

11.7.4.50 (ID 15576) Multi-setpoint Selection 0

Location in the menu: **P3.5.1.54**

Use this parameter to select the digital input signal that is used as a selector for the PID Multi-setpoint function.

11.7.4.51 (ID 15577) Multi-setpoint Selection 1

Location in the menu: **P3.5.1.55**

Use this parameter to select the digital input signal that is used as a selector for the PID Multi-setpoint function.

11.7.4.52 (ID 15578) Multi-setpoint Selection 2

Location in the menu: **P3.5.1.56**

Use this parameter to select the digital input signal that is used as a selector for the PID Multi-setpoint function.

11.7.4.53 (ID 15579) Multi-setpoint Selection 3

Location in the menu: **P3.5.1.57**

Use this parameter to select the digital input signal that is used as a selector for the PID Multi-setpoint function.

11.7.4.54 (ID 15590) Flow Switch

Location in the menu: **P3.5.1.58**

Use this parameter to select the digital input signal that is the feedback signal from the Flow Switch.

11.7.4.55 (ID 15513) AHF Over Temperature

- Location in the menu: **P3.5.1.59** (In I/O Configuration parameter menu)
- Location in the menu: **P3.23.3** (In Advanced Harmonic Filter parameter menu)

Use this parameter to set the digital input signal that activates AHF Over Temp (fault ID 1118).

11.7.5 Analog Inputs

11.7.5.1 (ID 377) AI1 Signal Selection

Location in the menu: **P3.5.2.1.1**

Use this parameter to connect the AI signal to the analog input of your selection.

This parameter is programmable. See [11.7.3 Default Functions of Programmable Inputs](#).

11.7.5.2 (ID 378) AI1 Signal Filter Time

Location in the menu: **P3.5.2.1.2**

Use this parameter to filter out disturbances in the analog input signal. To activate this parameter, enter a value greater than 0.

NOTICE

A long filter time makes the regulation response slow.

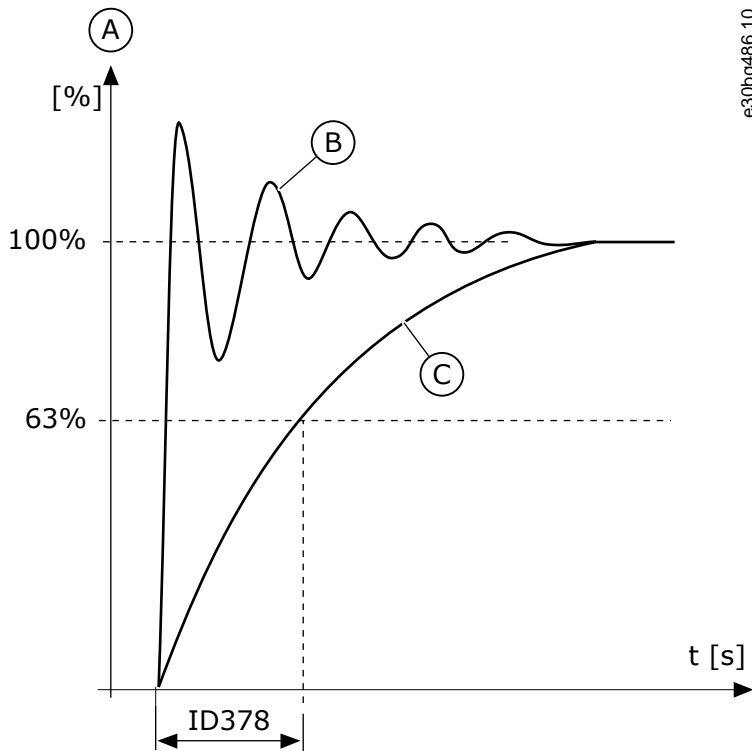

Illustration 56: The AI1 Signal Filtering

A	Analog input signal	C	Filtered signal
B	Unfiltered signal		

11.7.5.3 (ID 379) AI1 Signal Range

Location in the menu: P3.5.2.1.3

Use this parameter to change the range of the analog signal. The value of this parameter is bypassed if the custom scaling parameters are used.

Use the DIP switches on the control board to set the type of the analog input signal (current or voltage). For more information, see the Installation manual. It is also possible to use the analog input signal as frequency reference. The selection of the value 0 or 1 change the scaling of the analog input signal.

Selection number	Selection name	Description
0	0...10 V/0...20 mA	The range of the analog input signal is 0...10 V or 0...20 mA (the DIP switch settings on the control board tell which one). The input signal is 0...100%.
1	2...10 V/4...20 mA	The range of the analog input signal is 2...10 V or 4...20 mA (the DIP switch settings on the control board tell which one). The input signal is 20...100%.

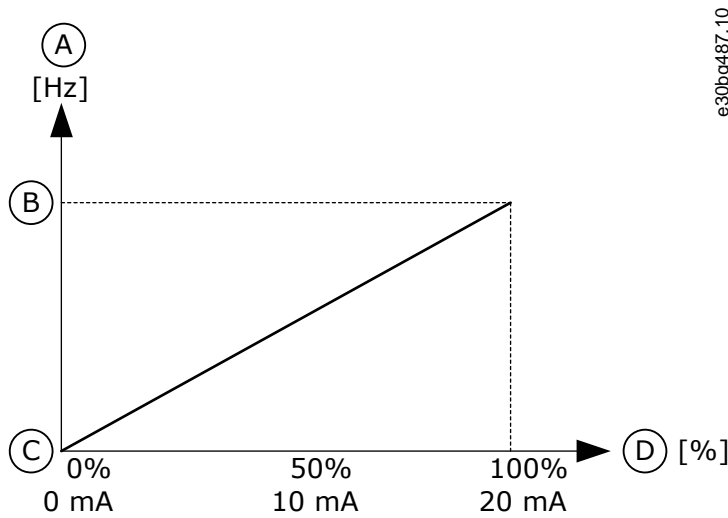

e30bg487.10

Illustration 57: The Analog Input Signal Range, Selection 0

A	Frequency reference	C	Min freq reference
B	Max freq reference	D	Analog input signal

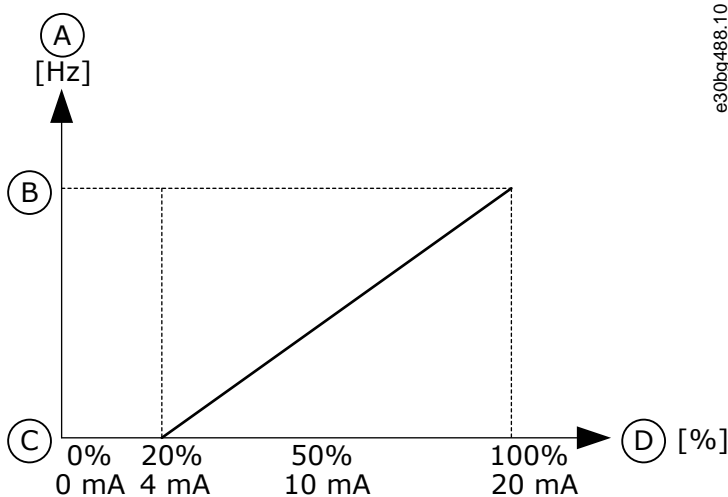

e30bg488.10

Illustration 58: The Analog Input Signal Range, Selection 1

A	Frequency reference	C	Min freq reference
B	Max freq reference	D	Analog input signal

11.7.5.4 (ID 380) AI1 Custom. MIN

Location in the menu: P3.5.2.1.4

Use this parameter to adjust the range of the analog input signal between -160% and 160%.

11.7.5.5 (ID 381) AI1 Custom. MAX

Location in the menu: P3.5.2.1.5

Use this parameter to adjust the range of the analog input signal between -160% and 160%.

Use the analog input signal, for example, as frequency reference, and set the parameters P3.5.2.1.4 and P3.5.2.1.5 between 40 and 80%. In these conditions, the frequency reference changes between the Minimum frequency reference and the Maximum frequency reference, and the analog input signal changes between 8 and 16 mA.

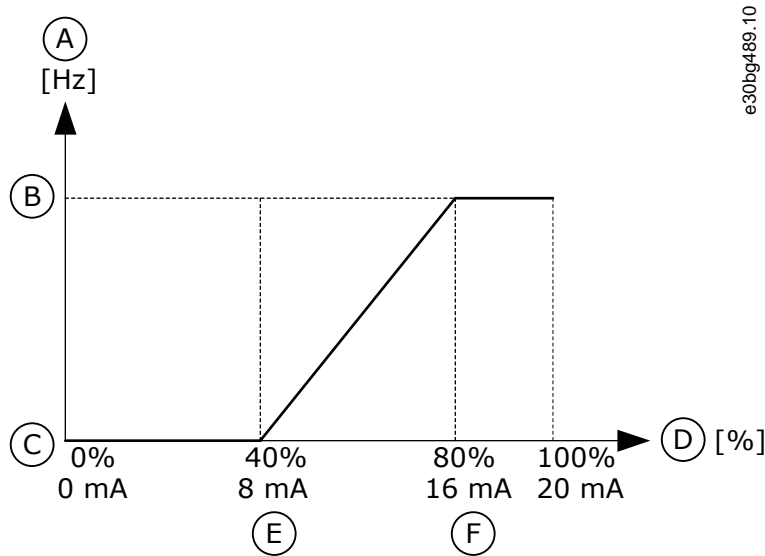

e30bg489.10

Illustration 59: AI1 Signal Custom. Min/Max

A	Frequency reference	D	Analog input signal
B	Max freq reference	E	AI custom min
C	Min freq reference	F	AI custom max

11.7.5.6 (ID 387) AI1 Signal Inversion

Location in the menu: P3.5.2.1.6

Use this parameter to invert the analog input signal. When the analog input signal is inverted, the curve of the signal becomes the opposite.

It is possible to use the analog input signal as frequency reference. The selection of the value 0 or 1 change scaling of the analog input signal.

Selection number	Selection name	Description
0	Normal	No inversion. The value 0% of the analog input signal agrees to the Minimum Frequency Reference. The value 100% of the analog input signal agrees to the Maximum Frequency Reference.
1	Inverted	Signal inversion. The value 0% of the analog input signal agrees to the Maximum Frequency Reference. The value 100% of the analog input signal agrees to the Minimum Frequency Reference.

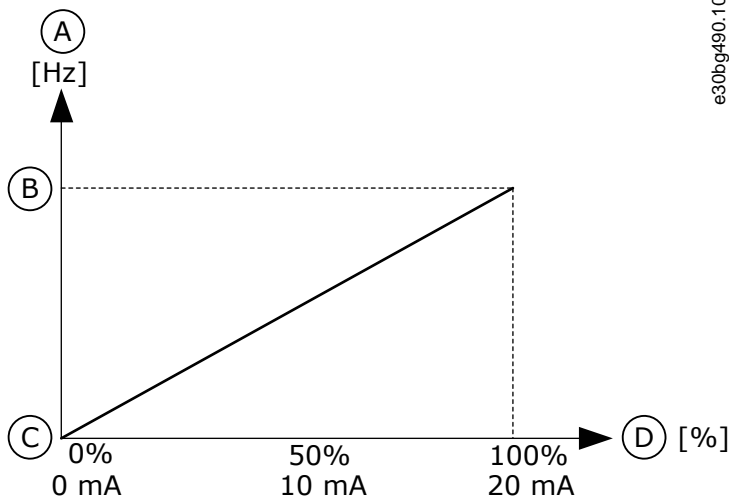

e30bg490.10

Illustration 60: AI1 Signal Inversion, Selection 0

A	Frequency reference	C	Minimum frequency reference
B	Maximum frequency reference	D	Analog input signal

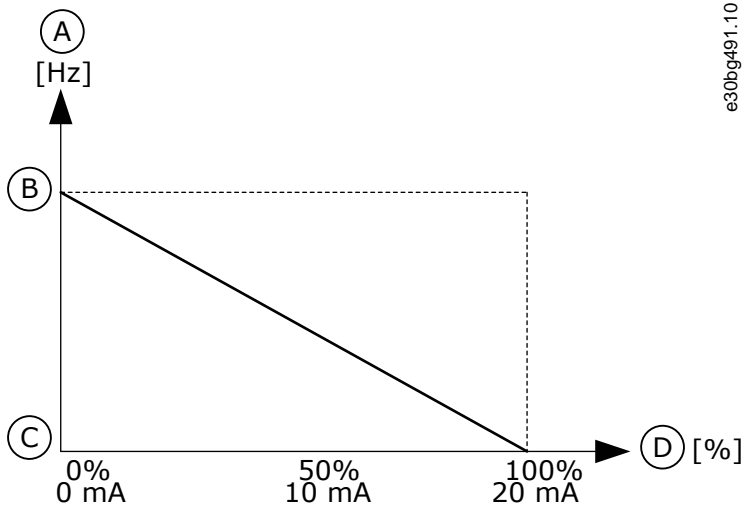

e30bg491.10

Illustration 61: AI1 Signal Inversion, Selection 1

A	Frequency reference	C	Minimum frequency reference
B	Maximum frequency reference	D	Analog input signal

11.7.6 Digital Outputs

11.7.6.1 (ID 11001) RO1 Function

Location in the menu: P3.5.3.2.1

Use this parameter to select a function or a signal that is connected to the relay output.

Selection number	Selection name	Description
0	Not used	The output is not used.
1	Ready	The AC drive is ready to operate.
2	Run	The AC drive operates (the motor runs).
3	General fault	A fault trip occurred.
4	General fault inverted	A fault trip did not occur.
5	General alarm	An alarm occurred.
6	Reversed	The reverse command is given.
7	At speed	The output frequency has become the same as the set frequency reference.
8	Thermistor fault	A thermistor fault occurred.
9	Motor regulator activated	One of the limit regulators (for example current limit or torque limit) is activated.
10	Start signal active	The start command of the drive is active.
11	Keypad control active	The selection is keypad control (the active control place is keypad).
12	I/O control B active	The selection is I/O control place B (the active control place is I/O B).
13	Limit supervision 1	The limit supervision activates if the signal value goes below or above the set supervision limit (P3.8.3 or P3.8.7).
14	Limit supervision 2	The limit supervision activates if the signal value goes below or above the set supervision limit (P3.8.3 or P3.8.7).
15	Fire mode active	The Fire mode function is active.
16	Flushing active	The Flushing function is active.
17	Preset Frequency active	The selection of preset frequency was made with digital input signals.
18	Quick Stop active	The Quick stop function is activated.
19	PID in Sleep mode	The PID controller is in the sleep mode.
20	PID Soft Fill activated	The Soft fill function of the PID controller is activated.
21	PID feedback supervision	The feedback value of the PID controller is not in the supervision limits.
22	ExtPID feedback supervision	The External PID controller feedback value is not in the supervision limits.
23	Input pressure alarm	The input pressure of the pump is below the value that was set with parameter P3.13.9.7.
24	Frost protection alarm	The measured temperature of the pump is below the level that was set with parameter P3.13.10.5.
25	Time channel 1	The status of Time channel 1.
26	Time channel 2	The status of Time channel 2.
27	Time channel 3	The status of Time channel 3.
28	Fieldbus Control Word bit 13	The digital (relay) output control from the Fieldbus control word bit 13.
29	Fieldbus Control Word bit 14	The digital (relay) output control from the Fieldbus control word bit 14.

Selection number	Selection name	Description
30	Fieldbus Control Word bit 15	The digital (relay) output control from the Fieldbus control word bit 15.
31	Fieldbus Process Data In1 bit 0	The digital (relay) output control from the Fieldbus Process Data In1, bit 0.
32	Fieldbus Process Data In1 bit 1	The digital (relay) output control from the Fieldbus Process Data In1, bit 1.
33	Fieldbus Process Data In1 bit 2	The digital (relay) output control from the Fieldbus Process Data In1, bit 2.
34	Maintenance counter 1 alarm	The maintenance counter reached the alarm limit that is set with parameter P3.16.2.
35	Maintenance counter 1 fault	The maintenance counter reached the alarm limit that is set with parameter P3.16.3.
36	Block Out.1	The output of the programmable Block 1. See parameter menu M3.19 Drive customizer.
37	Block Out.2	The output of the programmable Block 2. See parameter menu M3.19 Drive customizer.
38	Block Out.3	The output of the programmable Block 3. See parameter menu M3.19 Drive customizer.
39	Block Out.4	The output of the programmable Block 4. See parameter menu M3.19 Drive customizer.
40	Block Out.5	The output of the programmable Block 5. See parameter menu M3.19 Drive customizer.
41	Block Out.6	The output of the programmable Block 6. See parameter menu M3.19 Drive customizer.
42	Block Out.7	The output of the programmable Block 7. See parameter menu M3.19 Drive customizer.
43	Block Out.8	The output of the programmable Block 8. See parameter menu M3.19 Drive customizer.
44	Block Out.9	The output of the programmable Block 9. See parameter menu M3.19 Drive customizer.
45	Block Out.10	The output of the programmable Block 10. See parameter menu M3.19 Drive customizer.
46	Jockey pump control	The control signal for the external jockey pump.
47	Priming pump control	The control signal for the external priming pump.
48	Auto-cleaning active	The Pump auto-cleaning function is activated.
49	Multi-pump K1 control	The contactor control for the Multi-pump function.
50	Multi-pump K2 control	The contactor control for the Multi-pump function.
51	Multi-pump K3 control	The contactor control for the Multi-pump function.
52	Multi-pump K4 control	The contactor control for the Multi-pump function.
53	Multi-pump K5 control	The contactor control for the Multi-pump function.
54	Multi-pump K6 control	The contactor control for the Multi-pump function.

Selection number	Selection name	Description
55	Multi-pump K7 control	The contactor control for the Multi-pump function.
56	Multi-pump K8 control	The contactor control for the Multi-pump function.
69	Selected parameter set	Shows the active parameter set: OPEN = Parameter set 1 active CLOSED = Parameter set 2 active
72	AHF Capacitor Disconnection	
73	AHF Capacitor Disconnection Inverted	
74	Run Indication	
75	Motor Switch Open	The Motor Switch function has detected that the switch between the drive and the motor is open.

11.7.6.2 (ID 11002) RO1 ON Delay

Location in the menu: **P3.5.3.2.2**

Use this parameter to set the ON delay for the relay output.

11.7.6.3 (ID 11003) RO1 OFF Delay

Location in the menu: **P3.5.3.2.3**

Use this parameter to set the OFF delay for the relay output.

11.7.7 Analog Outputs

11.7.7.1 (ID 10050) AO1 Function

Location in the menu: **P3.5.4.1.1**

Use this parameter to select a function or a signal that is connected to the analog output. The contents of the analog output signal 1 are specified in this parameter. The scaling of the analog output signal depends on the signal.

Selection number	Selection name	Description
0	Test 0% (Not used)	The analog output is set to 0% or 20% so that it agrees with parameter P3.5.4.1.3.
1	TEST 100%	The analog output is set to 100% of the signal (10 V/20 mA).
2	Output frequency	The actual output frequency from 0 to Maximum frequency reference.
3	Frequency reference	The actual frequency reference from 0 to Maximum frequency reference.
4	Motor speed	The actual motor speed from 0 to Motor nominal speed.
5	Output current	The output current of the drive from 0 to Motor nominal current.
6	Motor torque	The actual motor torque from 0 to motor nominal torque (100%).
7	Motor power	The actual motor power from 0 to Motor nominal power (100%).
8	Motor voltage	The actual motor voltage from 0 to Motor nominal voltage.
9	DC link voltage	The actual DC link voltage 0...1000 V.
10	PID Setpoint	The actual setpoint value of the PID Controller (0...100%).

Selection number	Selection name	Description
11	PID Feedback	The actual feedback value of the PID Controller (0...100%).
12	PID output	The output of the PID controller (0...100%).
13	ExtPID output	The External PID controller output (0...100%).
14	Fieldbus Process Data In 1	Fieldbus Process Data In 1: 0...10000 (this agrees with 0... 100.00%).
15	Fieldbus Process Data In 2	Fieldbus Process Data In 2: 0...10000 (this agrees with 0... 100.00%).
16	Fieldbus Process Data In 3	Fieldbus Process Data In 3: 0...10000 (this agrees with 0... 100.00%).
17	Fieldbus Process Data In 4	Fieldbus Process Data In 4: 0...10000 (this agrees with 0... 100.00%).
18	Fieldbus Process Data In 5	Fieldbus Process Data In 5: 0...10000 (this agrees with 0... 100.00%).
19	Fieldbus Process Data In 6	Fieldbus Process Data In 6: 0...10000 (this agrees with 0... 100.00%).
20	Fieldbus Process Data In 7	Fieldbus Process Data In 7: 0...10000 (this agrees with 0... 100.00%).
21	Fieldbus Process Data In 8	Fieldbus Process Data In 8: 0...10000 (this agrees with 0... 100.00%).
22	Block Out.1	The output of the programmable Block 1: 0...10000 (this agrees with 0...100.00%). See parameter menu M3.19 Drive customizer.
23	Block Out.2	The output of the programmable Block 2: 0...10000 (this agrees with 0...100.00%). See parameter menu M3.19 Drive customizer.
24	Block Out.3	The output of the programmable Block 3: 0...10000 (this agrees with 0...100.00%). See parameter menu M3.19 Drive customizer.
25	Block Out.4	The output of the programmable Block 4: 0...10000 (this agrees with 0...100.00%). See parameter menu M3.19 Drive customizer.
26	Block Out.5	The output of the programmable Block 5: 0...10000 (this agrees with 0...100.00%). See parameter menu M3.19 Drive customizer.
27	Block Out.6	The output of the programmable Block 6: 0...10000 (this agrees with 0...100.00%). See parameter menu M3.19 Drive customizer.
28	Block Out.7	The output of the programmable Block 7: 0...10000 (this agrees with 0...100.00%). See parameter menu M3.19 Drive customizer.
29	Block Out.8	The output of the programmable Block 8: 0...10000 (this agrees with 0...100.00%). See parameter menu M3.19 Drive customizer.
30	Block Out.9	The output of the programmable Block 9: 0...10000 (this agrees with 0...100.00%). See parameter menu M3.19 Drive customizer.
31	Block Out.10	The output of the programmable Block 10: 0...10000 (this agrees with 0...100.00%). See parameter menu M3.19 Drive customizer.

11.7.7.2 (ID 10051) AO1 Filter Time

Location in the menu: **P3.5.4.1.2**

Use this parameter to set the filtering time for the analog signal. The filtering function is disabled when the filtering time is 0. See P3.5.2.1.2.

11.7.7.3 (ID 10052) AO1 Minimum

Location in the menu: **P3.5.4.1.3**

Use this parameter to change the range of the analog output signal. For example, if '4 mA' is selected, the range of analog output signal is 4...20 mA. Select the signal type (current/voltage) with the DIP switches. The analog output scaling is different in P3.5.4.1.4. See also P3.5.2.1.3.

11.7.7.4 (ID 10053) AO1 Minimum Scale

Location in the menu: **P3.5.4.1.4**

Use this parameter to scale the analog output signal. The scaling values (min and max) are given in the process unit specified by the selection of the AO function.

11.7.7.5 (ID 10054) AO1 Maximum Scale

Location in the menu: **P3.5.4.1.5**

Use this parameter to scale the analog output signal. The scaling values (min and max) are given in the process unit specified by the selection of the AO function.

Select, for example, the output frequency of the drive for the contents of the analog output signal, and set parameters P3.5.4.1.4 and P3.5.4.1.5 between 10 and 40 Hz. Then the output frequency of the drive changes between 10 and 40 Hz, and the analog output signal changes between 0 and 20 mA.

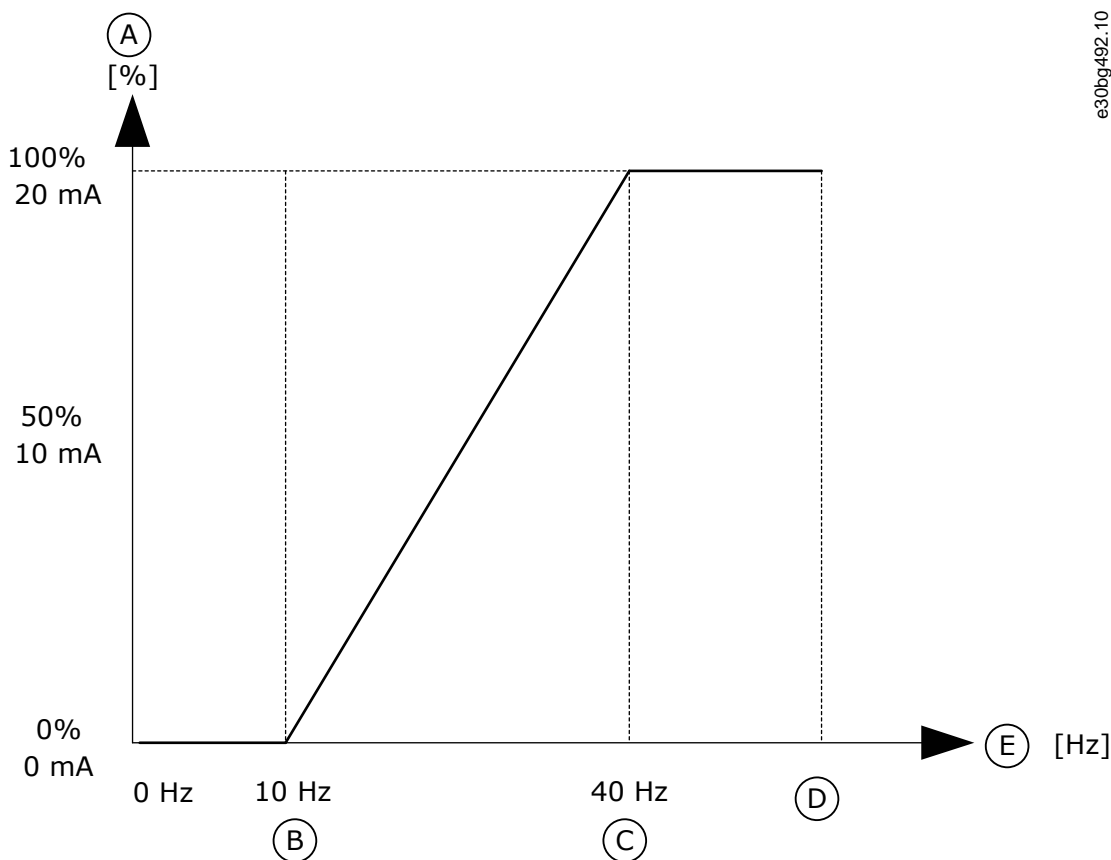

e30bg492.10

Illustration 62: Scaling of the AO1 Signal

A	Analog output signal	D	Maximum frequency reference
B	Analog output minimum scale	E	Output frequency
C	Analog output maximum scale		

11.8 Fieldbus Data

11.8.1 (ID 852) FB DataOut 1 Selection

Location in the menu: **P3.6.1**

Use this parameter to select the data that is sent to the fieldbus with the ID number of the parameter or monitor value.

The data is scaled to an unsigned 16-bit format according to the format on the control panel. For example, value 25.5 on the display equals 255.

11.8.2 (ID 853) FB DataOut 2 Selection

Location in the menu: **P3.6.2**

Use this parameter to select the data that is sent to the fieldbus with the ID number of the parameter or monitor value.

The data is scaled to an unsigned 16-bit format according to the format on the control panel. For example, value 25.5 on the display equals 255.

11.8.3 (ID 854) FB DataOut 3 Selection

Location in the menu: **P3.6.3**

Use this parameter to select the data that is sent to the fieldbus with the ID number of the parameter or monitor value.

The data is scaled to an unsigned 16-bit format according to the format on the control panel. For example, value 25.5 on the display equals 255.

11.8.4 (ID 855) FB DataOut 4 Selection

Location in the menu: **P3.6.4**

Use this parameter to select the data that is sent to the fieldbus with the ID number of the parameter or monitor value.

The data is scaled to an unsigned 16-bit format according to the format on the control panel. For example, value 25.5 on the display equals 255.

11.8.5 (ID 856) FB DataOut 5 Selection

Location in the menu: **P3.6.5**

Use this parameter to select the data that is sent to the fieldbus with the ID number of the parameter or monitor value.

The data is scaled to an unsigned 16-bit format according to the format on the control panel. For example, value 25.5 on the display equals 255.

11.8.6 (ID 857) FB DataOut 6 Selection

Location in the menu: **P3.6.6**

Use this parameter to select the data that is sent to the fieldbus with the ID number of the parameter or monitor value.

The data is scaled to an unsigned 16-bit format according to the format on the control panel. For example, value 25.5 on the display equals 255.

11.8.7 (ID 858) FB DataOut 7 Selection

Location in the menu: **P3.6.7**

Use this parameter to select the data that is sent to the fieldbus with the ID number of the parameter or monitor value.

The data is scaled to an unsigned 16-bit format according to the format on the control panel. For example, value 25.5 on the display equals 255.

11.8.8 (ID 859) FB DataOut 8 Selection

Location in the menu: **P3.6.8**

Use this parameter to select the data that is sent to the fieldbus with the ID number of the parameter or monitor value.

The data is scaled to an unsigned 16-bit format according to the format on the control panel. For example, value 25.5 on the display equals 255.

11.8.9 (ID 890) FB DataOut 9 Selection

Location in the menu: **P3.6.9**

Use this parameter to select the data that is sent to the fieldbus with the ID number of the parameter or monitor value.

The data is scaled to an unsigned 16-bit format according to the format on the control panel. For example, value 25.5 on the display equals 255.

11.8.10 (ID 891) FB DataOut 10 Selection

Location in the menu: **P3.6.10**

Use this parameter to select the data that is sent to the fieldbus with the ID number of the parameter or monitor value.

The data is scaled to an unsigned 16-bit format according to the format on the control panel. For example, value 25.5 on the display equals 255.

11.8.11 (ID 892) FB DataOut 11 Selection

Location in the menu: **P3.6.11**

Use this parameter to select the data that is sent to the fieldbus with the ID number of the parameter or monitor value.

The data is scaled to an unsigned 16-bit format according to the format on the control panel. For example, value 25.5 on the display equals 255.

11.8.12 (ID 893) FB DataOut 12 Selection

Location in the menu: **P3.6.12**

Use this parameter to select the data that is sent to the fieldbus with the ID number of the parameter or monitor value.

The data is scaled to an unsigned 16-bit format according to the format on the control panel. For example, value 25.5 on the display equals 255.

11.8.13 (ID 894) FB DataOut 13 Selection

Location in the menu: **P3.6.13**

Use this parameter to select the data that is sent to the fieldbus with the ID number of the parameter or monitor value.

The data is scaled to an unsigned 16-bit format according to the format on the control panel. For example, value 25.5 on the display equals 255.

11.8.14 (ID 895) FB DataOut 14 Selection

Location in the menu: **P3.6.14**

Use this parameter to select the data that is sent to the fieldbus with the ID number of the parameter or monitor value.

The data is scaled to an unsigned 16-bit format according to the format on the control panel. For example, value 25.5 on the display equals 255.

11.8.15 (ID 896) FB DataOut 15 Selection

Location in the menu: **P3.6.15**

Use this parameter to select the data that is sent to the fieldbus with the ID number of the parameter or monitor value.

The data is scaled to an unsigned 16-bit format according to the format on the control panel. For example, value 25.5 on the display equals 255.

11.8.16 (ID 897) FB DataOut 16 Selection

Location in the menu: **P3.6.16**

Use this parameter to select the data that is sent to the fieldbus with the ID number of the parameter or monitor value.

The data is scaled to an unsigned 16-bit format according to the format on the control panel. For example, value 25.5 on the display equals 255.

11.8.17 (ID 888) Fieldbus Sign of Actual

Location in the menu: **P3.6.17**

Use this parameter to select the behavior for the sign of the fieldbus Speed Actual.

Selection number	Selection name	Description
0	Positive	The sign of the actual is always positive. The running direction is visible from the status word bit 2. A TRUE value corresponds to reversing actual speed.
1	Actual direction	The sign of the actual follows the running direction. Forward is positive, reverse is negative. A TRUE value for status word bit 2 indicates if the direction of the actual differs from the direction requested from FB control commands.
2	Follow reference	A negative sign of the actual indicates if the direction of the actual differs from the direction requested from FB control commands. The status word bit 2 corresponds to the direction requested from FB control commands. A TRUE value corresponds to requested reversing.

11.9 Prohibit Frequencies

11.9.1 The Prohibit Frequencies Function

In some processes, it can be necessary to avoid some frequencies because they make problems of mechanical resonance. With the Prohibit frequencies function, it is possible to prevent the usage of these frequencies. When the input frequency reference increases, the internal frequency reference stays at the low limit, until the input frequency reference is above the high limit.

11.9.2 (ID 509) Prohibit Frequency Range 1 Low Limit

Location in the menu: **P3.7.1**

Use this parameter to prevent the drive operating on the prohibited frequencies.

In some processes, it can be necessary to avoid some frequencies because they cause mechanical resonance.

11.9.3 (ID 510) Prohibit Frequency Range 1 High Limit

Location in the menu: **P3.7.2**

Use this parameter to prevent the drive operating on the prohibited frequencies. In some processes, it can be necessary to avoid some frequencies because they cause mechanical resonance.

11.9.4 (ID 511) Prohibit Frequency Range 2 Low Limit

Location in the menu: **P3.7.3**

Use this parameter to prevent the drive operating on the prohibited frequencies. In some processes, it can be necessary to avoid some frequencies because they cause mechanical resonance.

11.9.5 (ID 512) Prohibit Frequency Range 2 High Limit

Location in the menu: **P3.7.4**

Use this parameter to prevent the drive operating on the prohibited frequencies. In some processes, it can be necessary to avoid some frequencies because they cause mechanical resonance.

11.9.6 (ID 513) Prohibit Frequency Range 3 Low Limit

Location in the menu: **P3.7.5**

Use this parameter to prevent the drive operating on the prohibited frequencies. In some processes, it can be necessary to avoid some frequencies because they cause mechanical resonance.

11.9.7 (ID 514) Prohibit Frequency Range 3 High Limit

Location in the menu: **P3.7.6**

Use this parameter to prevent the drive operating on the prohibited frequencies. In some processes, it can be necessary to avoid some frequencies because they cause mechanical resonance.

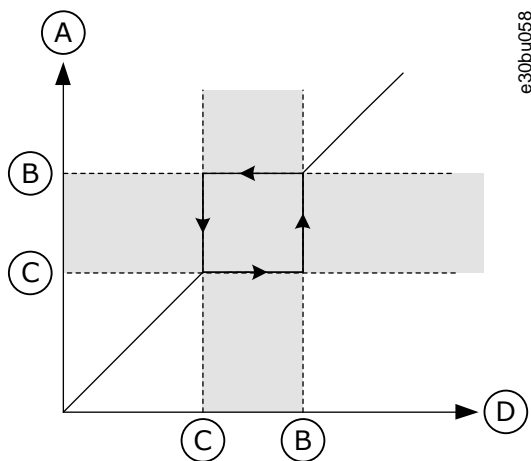

Illustration 63: The Prohibited Frequencies

A	Actual Reference	C	Low Limit
B	High Limit	D	Requested Reference

11.9.8 (ID 518) Ramp Time Factor

Location in the menu: P3.7.7

Use this parameter to set the multiplier of the selected ramp times when the output frequency of the drive is between the prohibited frequency limits. The Ramp Time Factor sets the acceleration and the deceleration time when the output frequency is in a prohibited frequency range. The value of the Ramp Time Factor is multiplied by the value of P3.4.1.2 (Acceleration Time 1) or P3.4.1.3 (Deceleration Time 1). For example, the value 0.1 makes the acceleration/deceleration time ten times shorter.

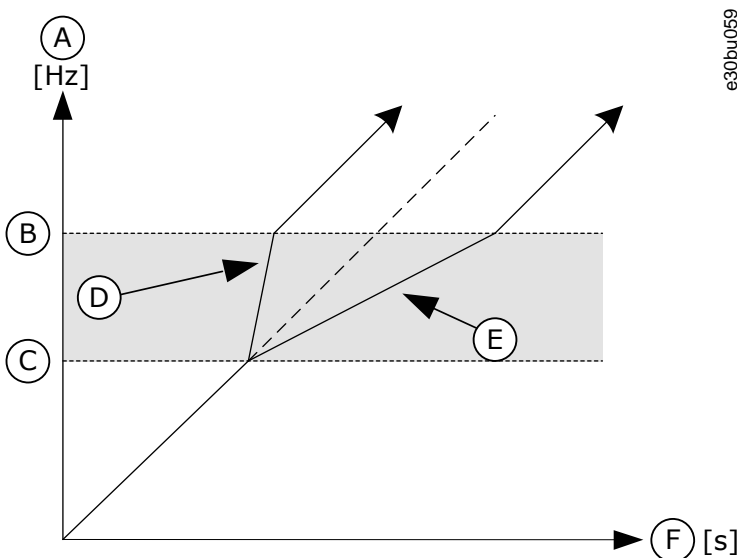

Illustration 64: The Parameter Ramp Time Factor

A	Output Frequency	D	Ramp Time Factor = 0.3
B	High Limit	E	Ramp Time Factor = 2.5
C	Low Limit	F	Time

11.10 Supervisions

11.10.1 (ID 1431) Supervision #1 Item Selection

Location in the menu: **P3.8.1**

Use this parameter to select the supervision item. The output of the supervision function can be selected to the relay output.

11.10.2 (ID 1432) Supervision #1 Mode

Location in the menu: **P3.8.2**

Use this parameter to set the supervision mode.

When the 'Low limit' mode is selected, the output of the supervision function is active when the signal is below the supervision limit.

When the 'High limit' mode is selected, the output of the supervision function is active when the signal is above the supervision limit.

11.10.3 (ID 1433) Supervision #1 Limit

Location in the menu: **P3.8.3**

Use this parameter to set the supervision limit for the selected item. The unit shows automatically.

11.10.4 (ID 1434) Supervision #1 Limit Hysteresis

Location in the menu: **P3.8.4**

Use this parameter to set the supervision limit hysteresis for the selected item. The unit shows automatically.

11.10.5 (ID 1435) Supervision #2 Item Selection

Location in the menu: **P3.8.5**

Use this parameter to select the supervision item. The output of the supervision function can be selected to the relay output.

11.10.6 (ID 1436) Supervision #2 Mode

Location in the menu: **P3.8.6**

Use this parameter to set the supervision mode.

11.10.7 (ID 1437) Supervision #2 Limit

Location in the menu: **P3.8.7**

Use this parameter to set the supervision limit for the selected item. The unit shows automatically.

11.10.8 (ID 1438) Supervision #2 Limit Hysteresis

Location in the menu: **P3.8.8**

Use this parameter to set the supervision limit hysteresis for the selected item. The unit shows automatically.

11.11 Protections

11.11.1 General

11.11.1.1 (ID 701) Response to External Fault

Location in the menu: **P3.9.1.2**

Use this parameter to select the response of the drive to an 'External Fault'.

If a fault occurs, the drive can show a notification of it on the display of the drive. An external fault is activated with a digital input signal. The default digital input is DI3. It is also possible to program the response data into a relay output.

11.11.1.2 (ID 730) Input Phase Fault

Location in the menu: **P3.9.1.3**

Use this parameter to select the supply phase configuration of the drive.

If the 1-phase supply is used, the value of this parameter must be set to 1-phase support.

11.11.1.3 (ID 727) Undervoltage Fault

Location in the menu: **P3.9.1.4**

Use this parameter to select if undervoltage faults are saved to the fault history or not.

11.11.1.4 (ID 702) Response to Output Phase Fault

Location in the menu: **P3.9.1.5**

Use this parameter to select the response of the drive to an 'Output Phase' fault. If the measurement of the motor current detects that there is no current in 1 motor phase, an output phase fault occurs. See P3.9.1.2.

11.11.1.5 (ID 733) Response to Fieldbus Communication Fault

Location in the menu: **P3.9.1.6**

Use this parameter to select the response of the drive to a fieldbus communication fault. If the data connection between the master and the fieldbus board is defective, a fieldbus fault occurs.

11.11.1.6 (ID 734) Slot Communication Fault

Location in the menu: **P3.9.1.7**

Use this parameter to select the response of the drive to a 'Slot Communication' fault. If the drive detects a defective option board, a slot communication fault occurs. See P3.9.1.2.

11.11.1.7 (ID 732) Thermistor Fault

Location in the menu: **P3.9.1.8**

Use this parameter to select the response of the drive to a 'Thermistor' fault. If the thermistor detects too high temperature, a thermistor fault occurs. See P3.9.1.2.

11.11.1.8 (ID 748) PID Soft Fill Fault

Location in the menu: **P3.9.1.9**

Use this parameter to select the response of the drive to a 'PID Soft Fill' fault. If the PIDFeedback value does not reach the set level within the time limit, a soft fill fault occurs. See P3.9.1.2.

11.11.1.9 (ID 749) Response to PID Supervision Fault

Location in the menu: **P3.9.1.10**

Use this parameter to select the response of the drive to a 'PID Supervision' fault. If the PID feedback value is not within the supervision limits for longer than the supervision delay, a PID supervision fault occurs. See P3.9.1.2.

11.11.1.10 (ID 757) Response to External PID Supervision Fault

Location in the menu: **P3.9.1.11**

Use this parameter to select the response of the drive to a 'PID Supervision' fault. If the PID feedback value is not within the supervision limits for longer than the supervision delay, a PID supervision fault occurs. See P3.9.1.2.

11.11.1.11 (ID 703) Earth Fault

Location in the menu: **P3.9.1.12**

Use this parameter to select the response of the drive to an 'Earth Fault'.

If the measurement of the current detects that the sum of the motor phase currents is not 0, an earth fault occurs. See P3.9.1.2.

NOTICE

It is possible to configure this fault only in enclosure sizes MR7, MR8, MR9, MR10, MR11, and MR12, and also MR6 600 V & 690 V.

11.11.1.12 (ID 183) Preset Alarm Frequency

Location in the menu: **P3.9.1.13**

Use this parameter to set the frequency of the drive when a fault is active and the response to the fault is set to 'Alarm + Preset Frequency'.

11.11.1.13 (ID 775) Response to Safe Torque Off (STO) Fault

Location in the menu: **P3.9.1.14**

Use this parameter to select the response of the drive to a 'STO Fault'.

This parameter defines drive operation when Safe Torque Off (STO) function is activated (for example, emergency stop button has been pressed or some other STO operation has been activated). See P3.9.1.2.

11.11.1.14 (ID 751) Fieldbus Communication Fault Force Delay

Location in the menu: **P3.9.1.17**

Use this parameter to set a delay for temporarily forcing the fault-response for fieldbus timeout from 'No Action', 'Alarm' or 'Alarm Preset Frequency' to 'Fault'. When a timeout occurs, the drive responds as selected with P3.9.1.6 and keeps running. After the delay time set by this parameter, the drive goes to a fault-state and the stop running.

If this parameter is set to 0.00 s, the fault-type remains as it is set with P3.9.1.6 and the drive runs indefinitely. If the fault-type is Fault or Fault-Coast, this delay does not affect anything.

11.11.1.15 (ID 752) Fieldbus Communication Fault Clear Delay

Location in the menu: **P3.9.1.18**

Use this parameter to set a delay for accepting new fieldbus start, reverse, and reference commands after a timeout has been cleared. The delay starts running after the connection has been re-established, and not after clearing a fieldbus timeout fault.

11.11.1.16 (ID 753) Unbalance Current Alarm

Location in the menu: **P3.9.1.19**

Use this parameter to set the response of the drive to an Unbalance Current Alarm. Available options are 'No Action' and 'Alarm'.

This option is only available for MR11 and MR12 enclosure sizes.

11.11.2 Motor Thermal Protections

The motor thermal protection prevents the motor from becoming too hot.

The AC drive can supply a current that is higher than the nominal current. The high current can be necessary to the load, and it must be used. In these conditions, there is a risk of a thermal overload. Low frequencies have a higher risk. At low frequencies, the cooling effect and the capacity of the motor decrease. If the motor has an external fan, the load reduction at low frequencies is small.

The motor thermal protection is based on calculations. The protection function uses the output current of the drive to know what is the load on the motor. If the control board is not energized, the calculations are reset.

To adjust the thermal protection of the motor, use the parameters from P3.9.2.1 to P3.9.2.5. It is possible to monitor the thermal status of the motor on the display of the control panel.

N O T I C E

If long motor cables (maximum 100 m) are used with small drives (≤ 1.5 kW), the motor current that the drive measures can be much higher than the actual motor current. It is because there are capacitive currents in the motor cable.

N O T I C E

OVERHEATING BECAUSE OF BLOCKED AIRFLOW

If the airflow to the motor is blocked, the function does not protect the motor, and the motor can become too hot. It can damage the motor.

- Make sure that the airflow to the motor is not blocked.

11.11.2.1 (ID 704) Motor Thermal Protection

Location in the menu: **P3.9.2.1**

Use this parameter to select the response of the drive to a 'Motor Overtemperature' fault. If the motor thermal protection function detects that the temperature of the motor is too high, a motor overtemperature fault occurs.

If possible, use a motor thermistor to protect the motor. Set the value of this parameter to 0.

11.11.2.2 (ID 705) Ambient Temperature

Location in the menu: **P3.9.2.2**

Use this parameter to set the ambient temperature where the motor is installed. The temperature value is given in Celsius or Fahrenheit degrees.

11.11.2.3 (ID 706) Zero Speed Cooling Factor

Location in the menu: **P3.9.2.3**

Use this parameter to set the cooling factor at 0 speed in relation to the point where the motor operates at nominal speed without external cooling.

The default value is set for conditions where there is no external fan. When using an external fan, the value can be set higher than without the fan, for example at 90%.

When changing parameter P3.1.1.4 (Motor Nominal Current), parameter P3.9.2.3 is automatically set to its default value.

Changing this parameter does not affect the maximum output current of the drive. Only parameter P3.1.3.1 *Motor Current Limit* can change the maximum output current.

The corner frequency for the thermal protection is 70% of the value of the parameter P3.1.1.2 Motor Nominal Frequency.

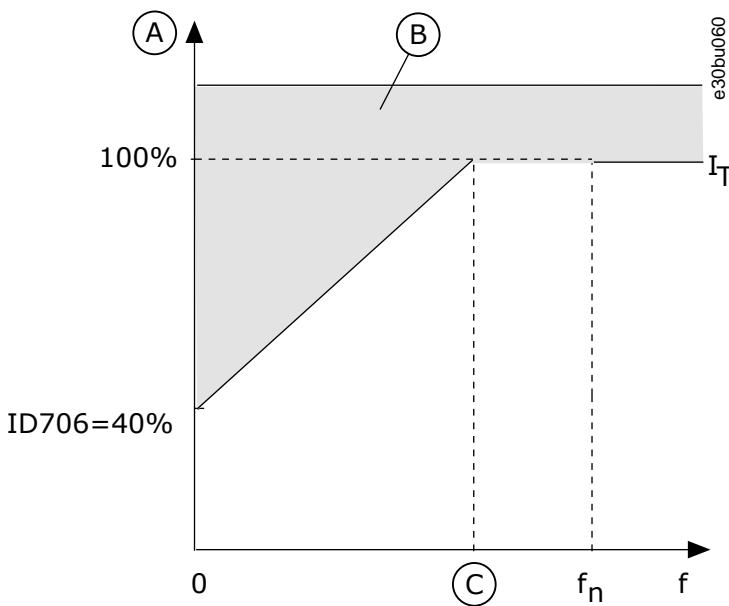

Illustration 65: The Motor Thermal Current I_T Curve

A	$P_{Cooling}$	C	Corner frequency
B	Overload area		

11.11.2.4 (ID 707) Motor Thermal Time Constant

Location in the menu: **P3.9.2.4**

Use this parameter to set the motor thermal time constant.

The time constant is the time within which the calculated thermal stage has reached 63% of its final value. The final thermal stage equals to running the motor continuously with nominal load at nominal speed. The length of the time constant is in relation with the dimension of the motor. The bigger the motor, the longer the time constant.

In different motors, the motor thermal time constant is different. It also changes between different motor manufacturers. The default value of the parameter changes from dimension to dimension.

The t_6 -time is the time in seconds that the motor can safely operate at 6 times the rated current. It is possible that the motor manufacturer gives the data with the motor. Use this information to set the time constant parameter. Usually, the motor thermal time constant in minutes is $2 \cdot t_6$. When the drive is in the *STOP* state, the time constant is internally increased to 3 times the set parameter value, because the cooling operates based on convection.

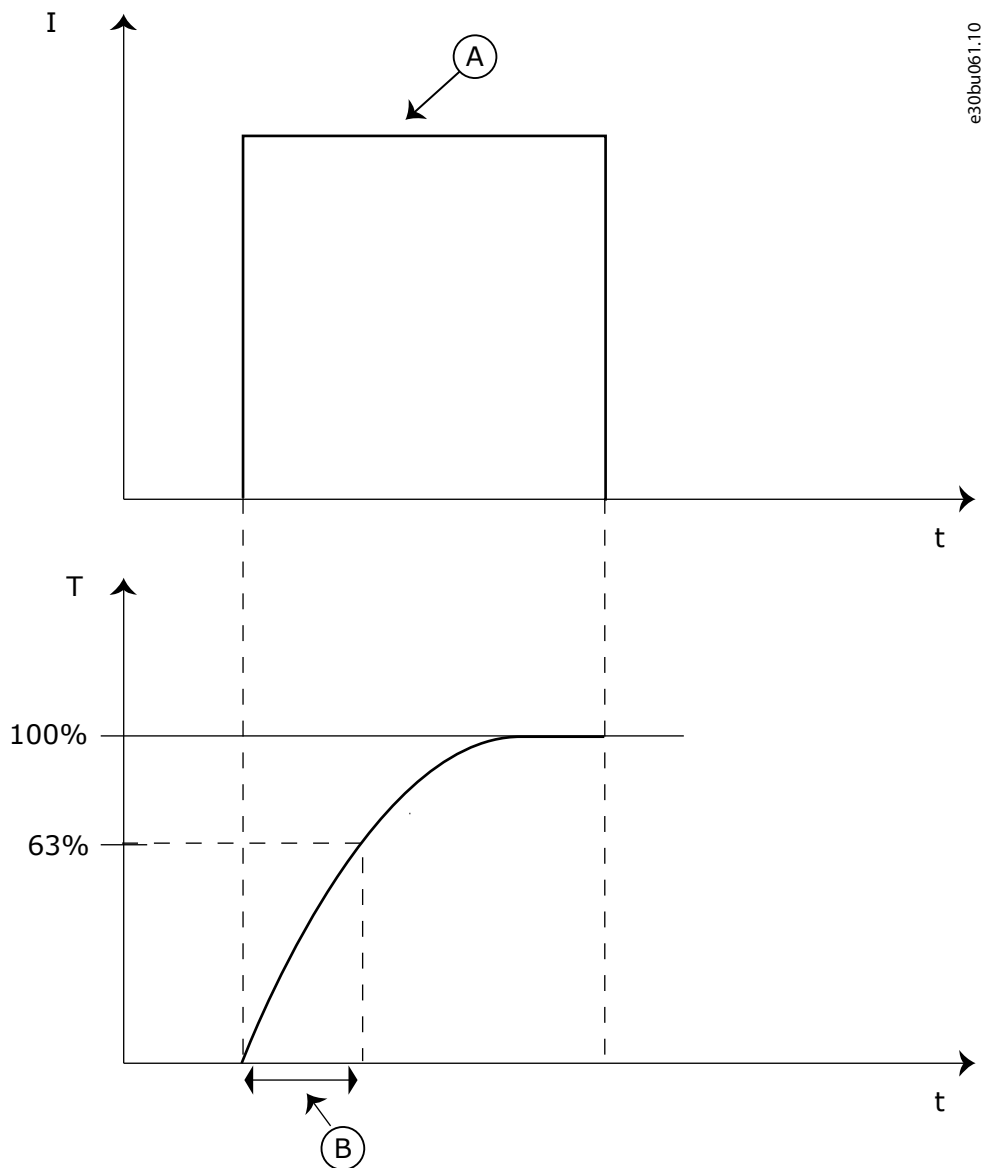

e30bu061.10

Illustration 66: The Motor Thermal Time Constant

- | | |
|---|-----------------------------|
| A | Current |
| B | Motor thermal time constant |

11.11.2.5 (ID 708) Motor Thermal Loadability

Location in the menu: P3.9.2.5

Use this parameter to set the thermal loadability of the motor. For example, if the value is set to 130%, the motor goes to the nominal temperature with 130% of the motor nominal current.

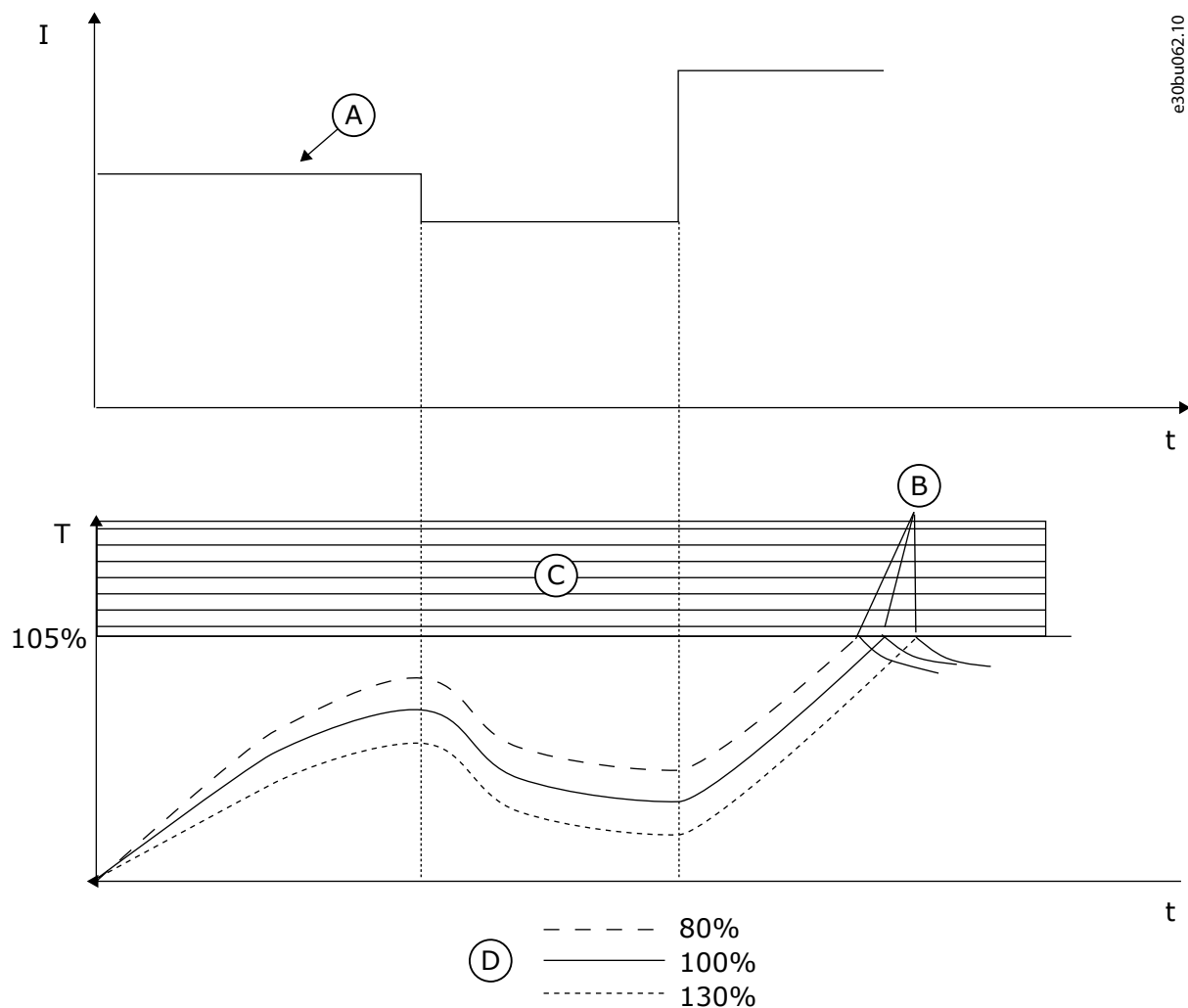

e30bu062.10

Illustration 67: The Calculation of the Motor Temperature

A	Current	C	Trip area
B	Fault/Alarm	D	Loadability

11.11.3 Motor Stall Protection

The motor stall protection function gives protection to the motor against short overloads. An overload can be caused, for example, by a stalled shaft. It is possible to set the reaction time of the stall protection shorter than that of the motor thermal protection.

The stall status of the motor is specified with parameters P3.9.3.2 Stall Current and P3.9.3.4 Stall Frequency Limit. If the current is higher than the limit, and the output frequency is lower than the limit, the motor is in a stall status.

The stall protection is a type of overcurrent protection.

NOTICE

If long motor cables (maximum 100 m) are used with small drives (≤ 1.5 kW), the motor current that the drive measures can be much higher than the actual motor current. It is because there are capacitive currents in the motor cable.

11.11.3.1 (ID 709) Motor Stall Fault

Location in the menu: **P3.9.3.1**

Use this parameter to select the response of the drive to a 'Motor Stall' fault. If the stall protection detects that the shaft of the motor is stalled, a motor stall fault occurs.

11.11.3.2 (ID 710) Stall Current

Location in the menu: **P3.9.3.2**

Use this parameter to set the limit above which the current of the motor must stay for a stall stage to occur.

It is possible to set the value of this parameter between 0.0 and $2 \cdot I_L$. For a stall status to occur, the current must be higher than this limit. If parameter P3.1.3.1 Motor Current Limit changes, this parameter is automatically calculated to 90% of the current limit.

The value of the Stall Current must be below the motor current limit.

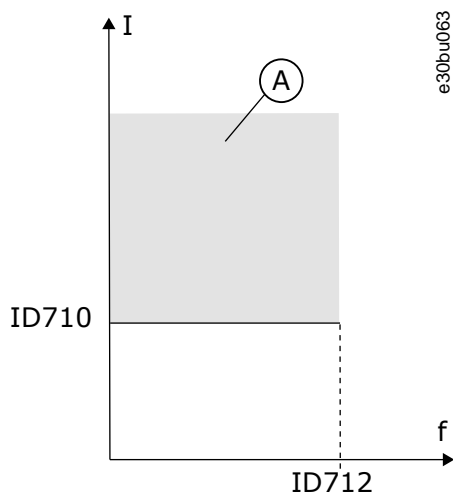

Illustration 68: The Stall Characteristics Settings

A	Stall area
---	------------

11.11.3.3 (ID 711) Stall Time Limit

Location in the menu: **P3.9.3.3**

Use this parameter to set the maximum time for a stall stage.

This parameter is the maximum time for the stall stage to be active before a motor stall fault occurs. The value of this parameter can be set between 1.0 s and 120.0 s. An internal counter counts the stall time. If the stall time counter value goes above this limit, the protection causes the drive to trip.

11.11.3.4 (ID 712) Stall Frequency Limit

Location in the menu: **P3.9.3.4**

Use this parameter to set the limit below which the output frequency of the drive must stay for a stall stage to occur.

For a stall state to occur, the output frequency must be below this limit for a certain time.

11.11.4 Underload (Dry Pump) Protection

The motor underload protection makes sure that there is a load on the motor when the drive operates. If the motor loses the load, a problem can occur in the process. For example, a belt can break or a pump become dry.

The motor underload protection can be adjusted with parameters P3.9.4.2 (Underload Protection: Field Weakening Area Load) and P3.9.4.3 (Underload Protection: Zero Frequency Load). The underload curve is a squared curve between the zero frequency and the field weakening point. The protection is not active below 5 Hz. The underload time counter does not operate below 5 Hz.

The values of the underload protection parameters are set in percentage of the nominal torque of the motor. To find the scaling ratio for the internal torque value, use the data in the nameplate data of the motor, the motor nominal current, and the nominal current of the drive IH. If another current than the nominal motor current is used, the precision of the calculation decreases.

NOTICE

If long motor cables (maximum 100 m) are used with small drives (≤ 1.5 kW), the motor current that the drive measures can be much higher than the actual motor current. It is because there are capacitive currents in the motor cable.

11.11.4.1 (ID 713) Underload Fault

Location in the menu: **P3.9.4.1**

Use this parameter to select the response of the drive to an 'Underload' fault. If the underload protection function detects that there is not a sufficient load on the motor, an underload fault occurs.

11.11.4.2 (ID 714) Underload Protection: Field Weakening Area Load

Location in the menu: **P3.9.4.2**

Use this parameter to set the minimum torque that the motor needs when the output frequency of the drive is higher than the frequency of the weakening point. It is possible to set the value of this parameter between 10.0% and 150.0% $\times T_{nMotor}$. This value is the limit for the minimum torque when the output frequency is above the field weakening point.

Changing parameter P3.1.1.4 (Motor Nominal Current) restores this parameter automatically to its default value. See [11.11.4 Underload \(Dry Pump\) Protection](#).

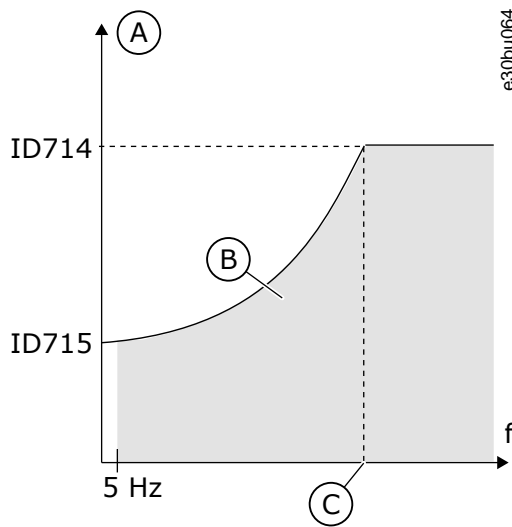

Illustration 69: Setting of the Minimum Load

A	Torque	C	Field weakening point
B	Underload area		

11.11.4.3 (ID 715) Underload Protection: Zero Frequency Load

Location in the menu: **P3.9.4.3**

Use this parameter to set the minimum torque that the motor needs when the output frequency of the drive is 0.

Changing the value of parameter P3.1.1.4 restores this parameter automatically to the default value.

11.11.4.4 (ID 716) Underload Protection: Time Limit

Location in the menu: **P3.9.4.4**

Use this parameter to set the maximum time for an underload state. It is the maximum time for the underload state to be active before an underload fault occurs.

It is possible to set the time limit between 2.0 s and 600.0 s.

An internal counter counts the underload time. If the value of the counter goes above this limit, the protection causes the drive to trip. The drive trips as is set in parameter P3.9.4.1 Underload Fault. If the drive stops, the underload counter goes back to 0.

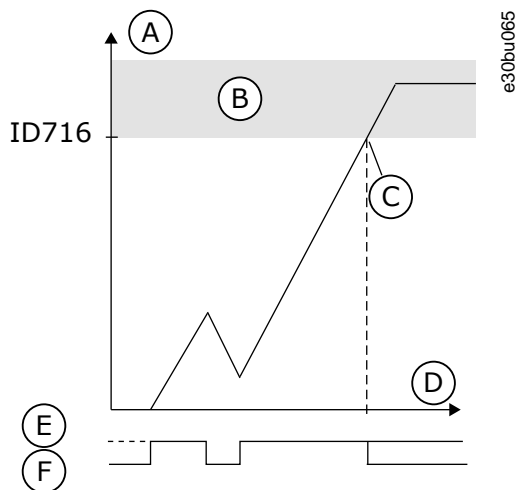

Illustration 70: The Underload Time Counter Function

A	Underload time counter	D	Time
B	Trip area	E	Underload
C	Trip/warning ID 713	F	No underload

11.11.5 Quick Stop

11.11.5.1 (ID 1276) Quick Stop Mode

Location in the menu: **P3.9.5.1**

Use this parameter to select how the drive stops when the quick stop command is given from DI or Fieldbus.

11.11.5.2 (ID 1213) Quick Stop Activation

Location in the menu: **P3.9.5.2**

Use this parameter to select the digital input signal that activates a Quick Stop function. The Quick Stop function stops the drive regardless of the control place or the state of the control signals.

11.11.5.3 (ID 1256) Quick Stop Deceleration Time

Location in the menu: **P3.9.5.3**

Use this parameter to set the time that is necessary for the output frequency to decrease from maximum frequency to 0 when a quick stop command is given. The value of this parameter is applied only when the quick stop mode parameter is set to 'Quick Stop Deceleration time'.

11.11.5.4 (ID 744) Response to Quick Stop Fault

Location in the menu: **P3.9.5.4**

Use this parameter to select the response of the drive to a 'Quick Stop' fault. If the quick stop command is given from DI or Fieldbus, a quick stop fault occurs.

With the quick stop function, it is possible to stop the drive in an unusual procedure from I/O or Fieldbus in unusual conditions. When the quick stop function is active, it is possible to make the drive decelerate and stop. It is possible to program an alarm or fault to put a mark in the fault history that there was a request for a quick stop.

⚠ CAUTION ⚠

Do not use the quick stop function as an emergency stop. An emergency stop must stop the power supply to the motor. The quick stop function does not do this.

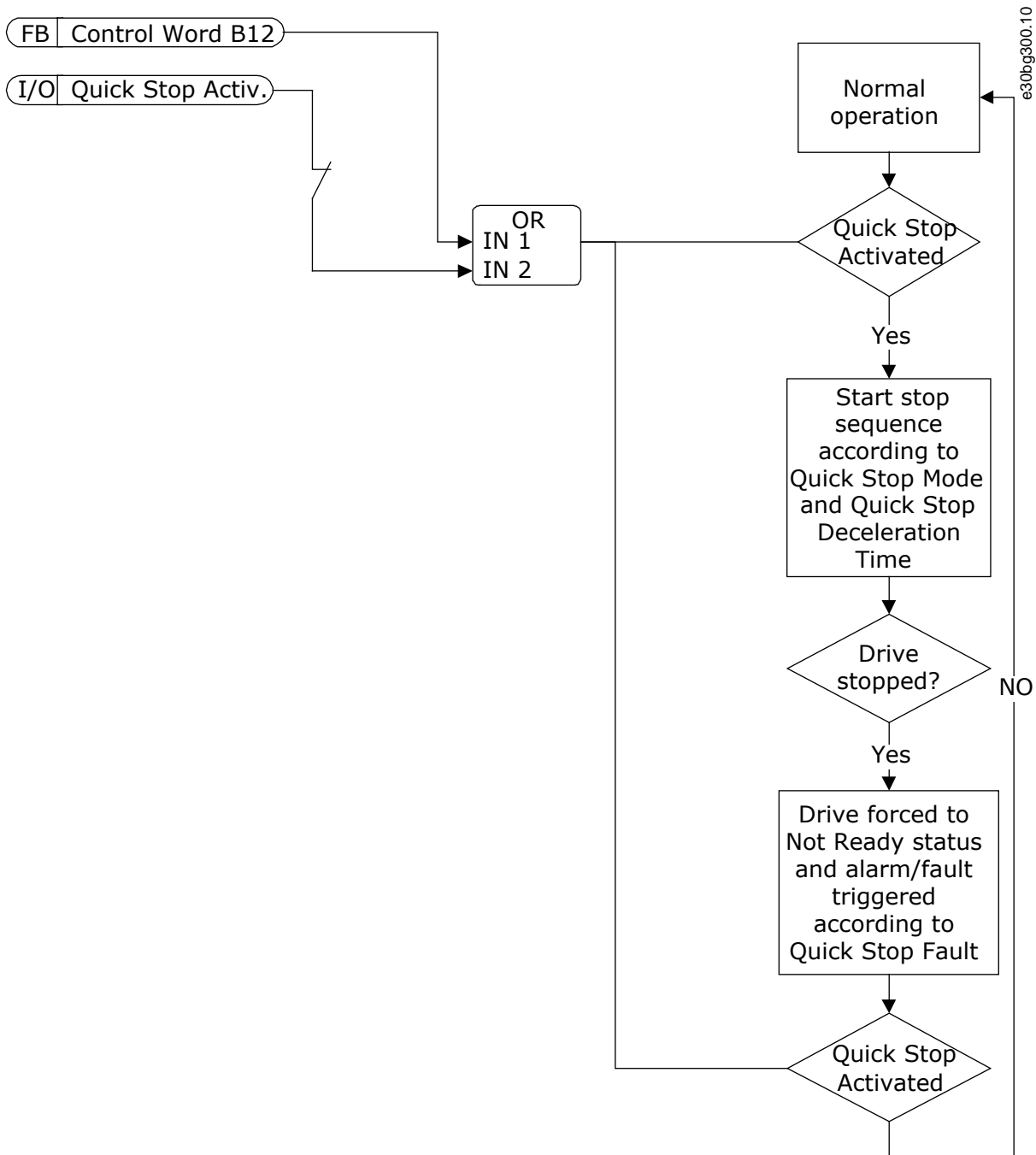

Illustration 71: The Quick Stop Logic

11.11.6 AI Low Protection

11.11.6.1 (ID 767) Analog Input Low Protection

Location in the menu: **P3.9.8.1**

Use this parameter to select when the AI Low supervision is enabled. For example, the AI Low supervision can be enabled only when the drive is in run state.

Use the AI Low Protection to find failures in the analog input signals. This function gives protection only to the analog inputs that are used as frequency reference, torque reference, or in the PID/ExtPID controllers.

It is possible to have the protection on when the drive is in the RUN status, or in the RUN and STOP statuses.

Selection number	Selection name	Description
0	Protection disabled	
1	Protection enabled in RUN status	The protection is enabled only when the drive is in the RUN status.
2	Protection enabled in RUN and STOP status	The protection is enabled in the 2 statuses, RUN, and STOP.

11.11.6.2 (ID 700) Analog Input Low Fault

Location in the menu: **P3.9.8.2**

Use this parameter to select the response of the drive to an 'AI Low' fault. If the analog input signal becomes less than 50% of the minimum signal for 500 ms, an AI Low fault occurs.

If AI Low Protection is enabled with parameter P3.9.8.1, this parameter gives a response for the fault code 50 (Fault ID 1050).

The AI low protection function monitors the signal level of the analog inputs 1–6. If the analog input signal becomes less than 50% of the minimum signal for 500 ms, an AI Low fault, or alarm shows.

N O T I C E

It is possible to use the value Alarm + previous frequency only when using analog input 1 or analog input 2 as frequency reference.

Selection number	Selection name	Description
0	No Action	AI Low Protection is not used.
1	Alarm	
2	Alarm, preset frequency	The frequency reference is set as in P3.9.1.13 Preset Alarm Frequency.
3	Alarm, previous frequency	The last valid frequency is kept as frequency reference.
4	Fault	The drive stops as is set in P3.2.5 Stop Mode.
5	Fault, coasting	The drive stops by coasting.

11.12 Automatic Reset

11.12.1 (ID 731) Automatic Reset

Location in the menu: **P3.10.1**

Use this parameter to enable the Automatic reset function. To select the faults that are reset automatically, enter the value 0 or 1 to parameters from P3.10.6 to P3.10.13.

N O T I C E

The automatic reset function is available only for some fault types.

11.12.2 (ID 719) Restart Function

Location in the menu: **P3.10.2**

Use this parameter to select the start mode for the Automatic reset function.

11.12.3 (ID 717) Wait Time

Location in the menu: **P3.10.3**

Use this parameter to set the wait time before the first reset is done.

11.12.4 (ID 718) Trial Time

Location in the menu: **P3.10.4**

Use this parameter to set the trial time for the automatic reset function. During the trial time, the automatic reset function tries to reset the faults that occur.

The time count starts from the first automatic reset. The next fault starts the trial time count again.

11.12.5 (ID 759) Number of Trials

Location in the menu: **P3.10.5**

Use this parameter to set the total number of auto reset trials. If the number of trials during the trial time is more than the value of this parameter, a permanent fault shows. If not, the fault goes out of view after the trial time is completed. The fault type does not affect the maximum number of trials.

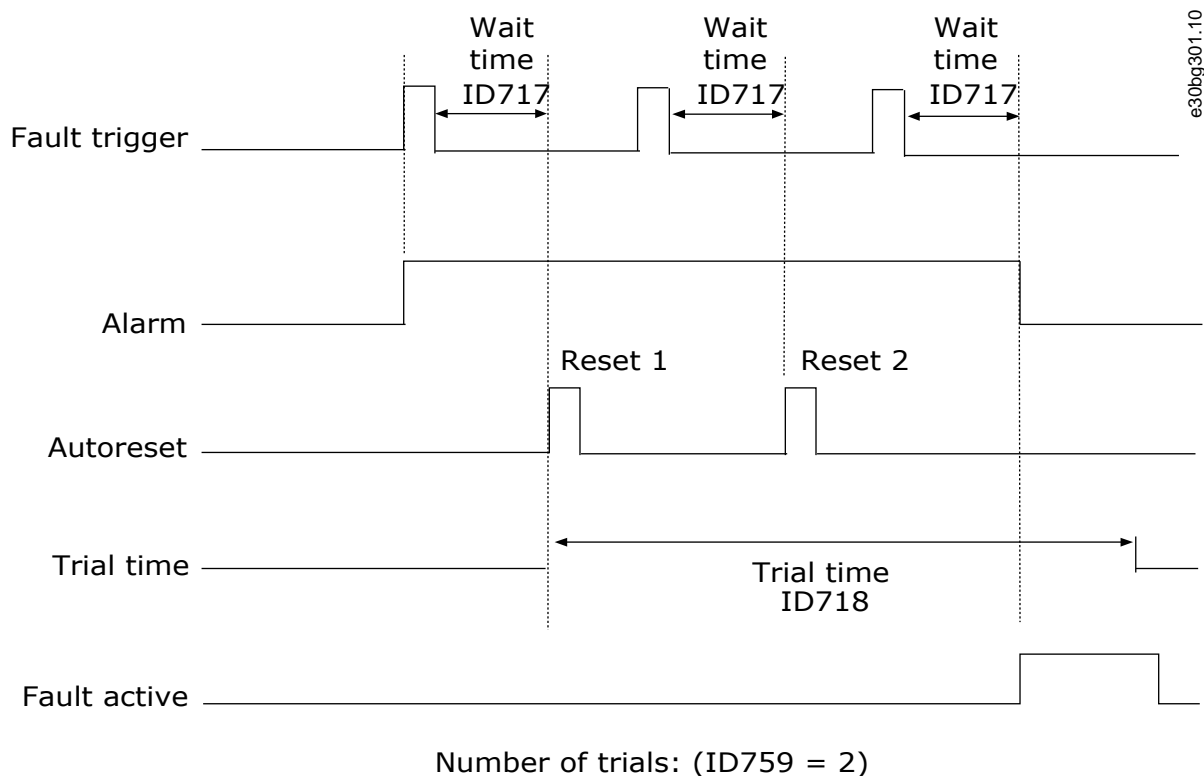

Illustration 72: The Automatic Reset Function

11.12.6 (ID 720) Autoreset: Undervoltage

Location in the menu: **P3.10.6**

Use this parameter to enable the automatic reset after an undervoltage fault.

11.12.7 (ID 721) Autoreset: Overvoltage

Location in the menu: **P3.10.7**

Use this parameter to enable the automatic reset after an overvoltage fault.

11.12.8 (ID 722) Autoreset: Overcurrent

Location in the menu: **P3.10.8**

Use this parameter to enable the automatic reset after an overcurrent fault.

11.12.9 (ID 723) Autoreset: AI Low

Location in the menu: **P3.10.9**

Use this parameter to enable the automatic reset after a fault caused by low AI signal.

11.12.10 (ID 724) Autoreset: Unit Overtemperature

Location in the menu: **P3.10.10**

Use this parameter to enable the automatic reset after a fault caused by unit overtemperature.

11.12.11 (ID 725) Autoreset: Motor Overtemperature

Location in the menu: **P3.10.11**

Use this parameter to enable the automatic reset after a fault caused by motor overtemperature.

11.12.12 (ID 726) Autoreset: External Fault

Location in the menu: **P3.10.12**

Use this parameter to enable the automatic reset after an external fault.

11.12.13 (ID 738) Autoreset: Underload Fault

Location in the menu: **P3.10.13**

Use this parameter to enable the automatic reset after an underload fault.

11.12.14 (ID 776) Autoreset: PID Supervision Fault

Location in the menu: **P3.10.14**

Use this parameter to enable the automatic reset after a PID supervision fault.

11.12.15 (ID 777) Autoreset: EXT PID Supervision Fault

Location in the menu: **P3.10.15**

Use this parameter to enable the automatic reset after an external PID supervision fault.

11.12.16 (ID 1569) Fault Simulation

Location in the menu: **P3.10.16**

With this parameter it is possible to simulate the different faults without them being actually active. For example simulating an over current situation. In the drive interface point of view the behavior is identical to actual fault situations.

Selection	Name	Description
B00	1 ₁₀	Over current fault (F1)
B01	2 ₁₀	Over voltage fault (F2)
B02	4 ₁₀	Under voltage fault (F9)
B03	8 ₁₀	Output phase supervision fault (F11)
B04	16 ₁₀	Earth voltage fault (F3)
B05	32 ₁₀	System fault (F8)
B06	64 ₁₀	Over temperature warning (W14)
B07	128 ₁₀	Over temperature fault (F14) ⁽¹⁾
B08	256 ₁₀	Reserved
B09	512 ₁₀	Reserved
B10	1024 ₁₀	Fan cooling fault (F32)

¹ The warning bit needs to be high also for this fault simulation to work.

11.13 Application Settings

11.13.1 (ID 1806) Password

Location in the menu: **P3.11.1**

Use this parameter to set the administrator password.

11.13.2 (ID 1197) C/F Selection

Location in the menu: **P3.11.2**

Use this parameter to set the temperature measuring unit. The system shows all the temperature-related parameters and monitoring values in the set unit.

11.13.3 (ID 1198) kW/HP Selection

Location in the menu: **P3.11.3**

Use this parameter to set the power measuring unit. The system shows all the power-related parameters and monitoring values in the set unit.

11.13.4 (ID 1196) Multimonitor View

Location in the menu: **P3.11.4**

Use this parameter to set the division of the display of the control panel into sections in the multimonitor view.

11.13.5 (ID 1195) [FUNCT] Button Configuration

Location in the menu: **P3.11.5**

Use this parameter to set the values of the [FUNCT] button. The values set with this parameter are available when pushing the [FUNCT] button on the keypad.

11.13.6 (ID 1807) Set Parameter Lock

Location in the menu: **P3.11.6**

Use this parameter to set a password for edit-locking all parameters. Parameters are locked if value is set greater than zero. To disable the lock, open the lock with a correct key, and set the lock-password back to zero.

NOTE! After setting this parameter to larger than zero (0), the lock is immediately active. Setting a lock also locks and hide this parameter itself. Control place cannot be changed over to Local, when the lock is in place.

11.13.7 (ID 1808) Parameter Lock Key

Location in the menu: **P3.11.7**

Use this parameter to enter a password for opening the parameter edit-lock. The lock is opened if the values of the Key- and Lock-passwords are equal.

11.14 Timer Functions

11.14.1 Introduction to Timer Functions

The timer functions make it possible for the internal RTC (real-time clock) to control functions. All the functions that can be controlled with a digital input, can also be controlled with the RTC, with time channels 1–3. It is not necessary to have an external PLC to control a digital input. It is possible program the closed and opened intervals of the input internally.

To get the best results of the timer functions, install a battery, and make the settings of the real-time clock carefully in the Start-up wizard. The battery is available as an option.

NOTICE

It is not recommended to use the timer functions without an auxiliary battery. The time and date settings of the drive are reset at each power down, if there is no battery for the RTC.

11.14.2 Time Channels, Intervals, and Timers

Time Channels

It is possible to assign the output of the interval and/or timer functions to time channels 1–3. It is possible to use the time channels to control on/off type functions, for example relay outputs or digital inputs. To configure the on/off logic of the time channels, assign intervals and/or timers to them. A time channel can be controlled by many different intervals or timers.

Assigning intervals and timers to time channels is flexible. Every interval and timer has a parameter with which to assign them to a time channel.

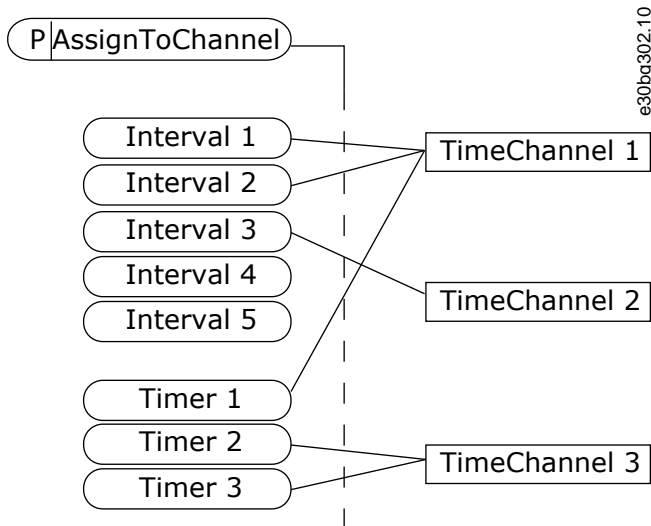

Illustration 73: Assigning Intervals and Timers to time Channels

Intervals

Use parameters to give each interval an ON Time and OFF Time. It is the daily active time of the interval during the days set with parameters From Day and To Day. For example, with the parameter settings below, the interval is active from 7 am to 9 am from Monday to Friday. The time channel is like a digital input, but virtual.

- ON Time: 07:00:00
- OFF Time: 09:00:00
- From Day: Monday
- To Day: Friday

Timers

Use the timers to set a time channel as active for a period with a command from a digital input or a time channel.

In the following figure, the activation signal comes from a digital input or a virtual digital input, like a time channel. The timer counts down from the falling edge.

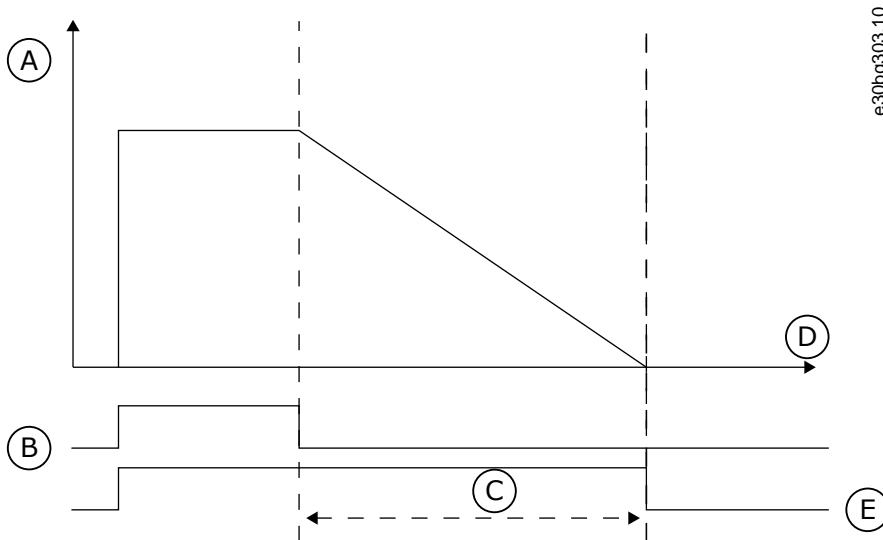

Illustration 74: The Activation Signal from Digital Input or Virtual Digital Input

A	Remaining time	D	Time
B	Activation	E	OUT
C	Duration		

The following parameters set the timer active when the digital input 1 on the slot A is closed. They will also keep the timer active for 30 s after it is opened.

- Duration: 30 s
- Timer: DigIn SlotA.1

It is possible use a duration of 0 s to override a time channel that is activated from a digital input. There is no off delay after the falling edge.

Example

Problem: The AC drive is in a warehouse and controls air conditioning. It must operate between 7 am and 5 pm on weekdays and between 9 am and 1 pm on weekends. It is also necessary for the drive to operate outside these hours, if there are personnel in the building. The drive must continue to operate 30 minutes after the personnel has left.

Solution: Set 2 intervals, 1 for weekdays and 1 for weekends. A timer is also necessary to activate the process outside the set hours. See the following configuration.

Interval 1

- P3.12.1.1: ON Time: 07:00:00
- P3.12.1.2: OFF Time: 17:00:00
- P3.12.1.3: Days: Monday, Tuesday, Wednesday, Thursday, Friday
- P3.12.1.4: Assign to channel: Time channel 1

Interval 2

- P3.12.2.1: ON Time: 09:00:00
- P3.12.2.2: OFF Time: 13:00:00
- P3.12.2.3: Days: Saturday, Sunday
- P3.12.2.4: Assign to channel: Time channel 1

Timer 1

- P3.12.6.1: Duration: 1800 s (30 min)
- P3.12.6.2: Timer 1: DigIn SlotA.1 (The parameter is in the digital inputs menu.)
- P3.12.6.3: Assign to channel: Time channel 1
- P3.5.1.1: Control signal 1 A: Time Channel 1 for the I/O Run command

In the following figure, Time Channel 1 is used as the control signal for the start command instead of a digital input.

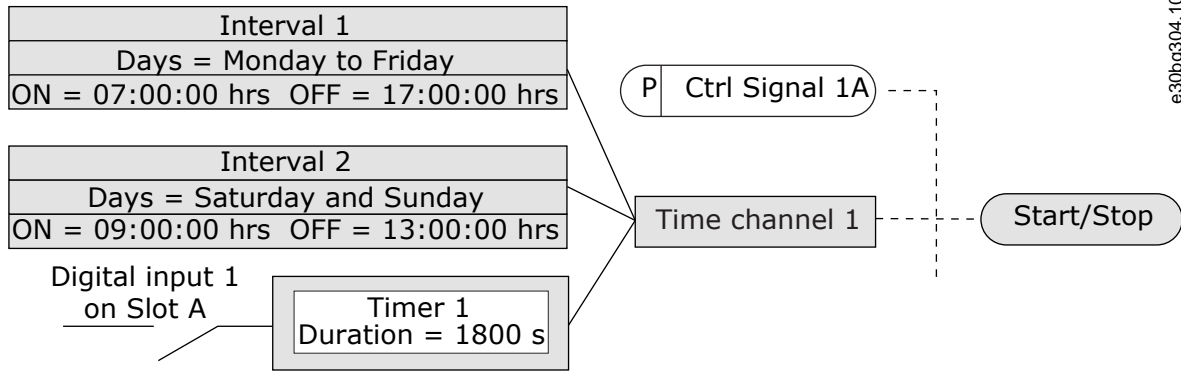

e30bg304.10

Illustration 75: Time Channel 1 as the Control Signal for the Start Command

11.14.3 Editing an Interval

Procedure

1. Activate the interval to edit.
2. Go into parameter Days (ID 1466).

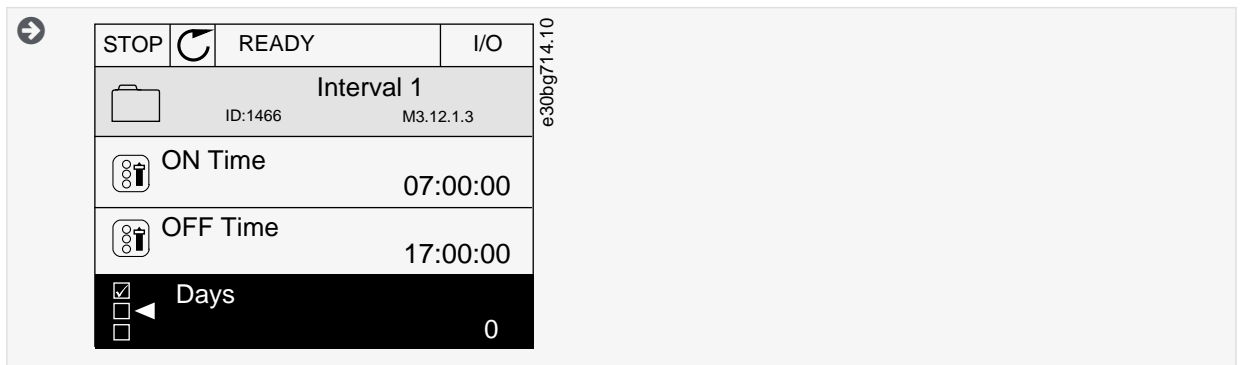

e30bg714.10

3. Go into the Edit mode.
4. Select the necessary weekdays in the checkbox selection.

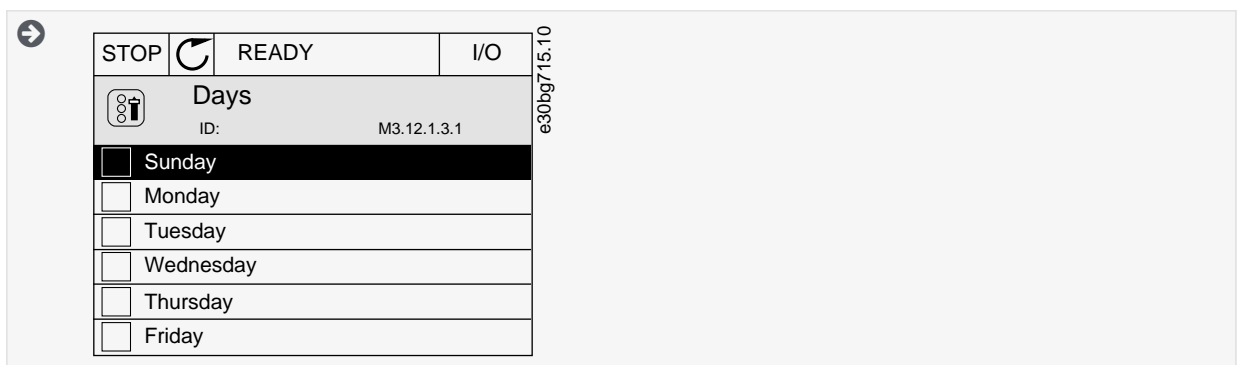

e30bg715.10

11.14.4 (ID 1464) ON Time

Location in the menu: P3.12.1.1

Use this parameter to set the time of day when the output of the interval function is activated.

11.14.5 (ID 1465) OFF Time

Location in the menu: P3.12.1.2

Use this parameter to set the time of day when the output of the interval function is deactivated.

11.14.6 (ID 1466) Days

Location in the menu: **P3.12.1.3**

Use this parameter to select the days of the week when the interval function is enabled.

11.14.7 (ID 1468) Assign to Channel

Location in the menu: **P3.12.1.4**

Use this parameter to select the time channel where the output of the interval function is assigned. It is possible to use the time channels to control the on/off type functions, for example relay outputs or any functions that can be controlled by a DI signal.

11.14.8 (ID 1489) Duration

Location in the menu: **P3.12.6.1**

Use this parameter to set the duration that the timer runs when the activation signal is removed (Off-delay).

11.14.9 (ID 447) Timer 1

Location in the menu: **P3.12.6.2**

Use this parameter to select the digital input signal that starts the timer. The output of the timer is activated when this signal is activated. The timer starts to count when this signal is deactivated (falling edge). The output is deactivated when the time that is set with the duration parameter has elapsed. The rising edge starts Timer 1 that is programmed in Group 3.12.

11.14.10 (ID 1490) Assign to Channel

Location in the menu: **P3.12.6.3**

Use this parameter to select the time channel where the output of the timer function is assigned. It is possible to use the time channels to control the on/off type functions, for example relay outputs or any functions that can be controlled by a DI signal.

11.15 PID Controller

11.15.1 Basic Settings

11.15.1.1 (ID 118) PID Gain

Location in the menu: **P3.13.1.1**

Use this parameter to adjust the gain of the PID controller. If this parameter is set to 100%, a change of 10% in the error value causes the controller output to change by 10%.

11.15.1.2 (ID 119) PID Integration Time

Location in the menu: **P3.13.1.2**

Use this parameter to adjust the integration time of the PID controller. If this parameter is set to 1.00 s, a change of 10% in the error value causes the controller output to change by 10.00%/s.

11.15.1.3 (ID 132) PID Derivation Time

Location in the menu: **P3.13.1.3**

Use this parameter to adjust the derivation time of the PID controller. If this parameter is set to 1.00 s, a change of 10% in the error value during 1.00 s causes the controller output to change by 10.00%.

11.15.1.4 (ID 1036) Process Unit Selection

Location in the menu: **P3.13.1.4**

Use this parameter to select the unit for the feedback and the setpoint signals of the PID controller. Select the unit for the actual value.

11.15.1.5 (ID 1033) Process Unit MIN

Location in the menu: **P3.13.1.5**

Use this parameter to set the minimum value of the PID feedback signal. For example, an analog signal of 4...20 mA corresponds to the pressure of 0...10 bar. The value in process units at a 0% feedback or setpoint. This scaling is done for monitoring purposes only. The PID controller still uses the percentage internally for feedbacks and setpoints.

11.15.1.6 (ID 1034) Process Unit MAX

Location in the menu: **P3.13.1.6**

Use this parameter to set the maximum value of the PID feedback signal. For example, an analog signal of 4...20 mA corresponds to the pressure of 0...10 bar. The value in process units at a 0% feedback or setpoint. This scaling is done for monitoring purposes only. The PID controller still uses the percentage internally for feedbacks and setpoints.

11.15.1.7 (ID 1035) Process Unit Decimals

Location in the menu: **P3.13.1.7**

Use this parameter to set the number of decimals for the process unit values. For example, an analog signal of 4...20 mA corresponds to the pressure of 0...10 bar. The value in process units at a 0% feedback or setpoint. This scaling is done for monitoring purposes only. The PID controller still uses the percentage internally for feedbacks and setpoints.

11.15.1.8 (ID 340) Error Inversion

Location in the menu: **P3.13.1.8**

Use this parameter to invert the error value of the PID controller.

11.15.1.9 (ID 1056) Dead Band

Location in the menu: **P3.13.1.9**

Use this parameter to set the dead band area around the PID setpoint value. The value of this parameter is given in the selected process unit. The output of the PID controller is locked if the feedback value stays in the dead band area for the set time.

11.15.1.10 (ID 1057) Dead Band Delay

Location in the menu: **P3.13.1.10**

Use this parameter to set the time that the feedback value must stay in the dead band area before the output of the PID controller is locked. If the actual value stays in the dead band area for a time set in Dead Band Delay, the PID controller output is locked. This function prevents wear and unwanted movements of the actuators, for example valves.

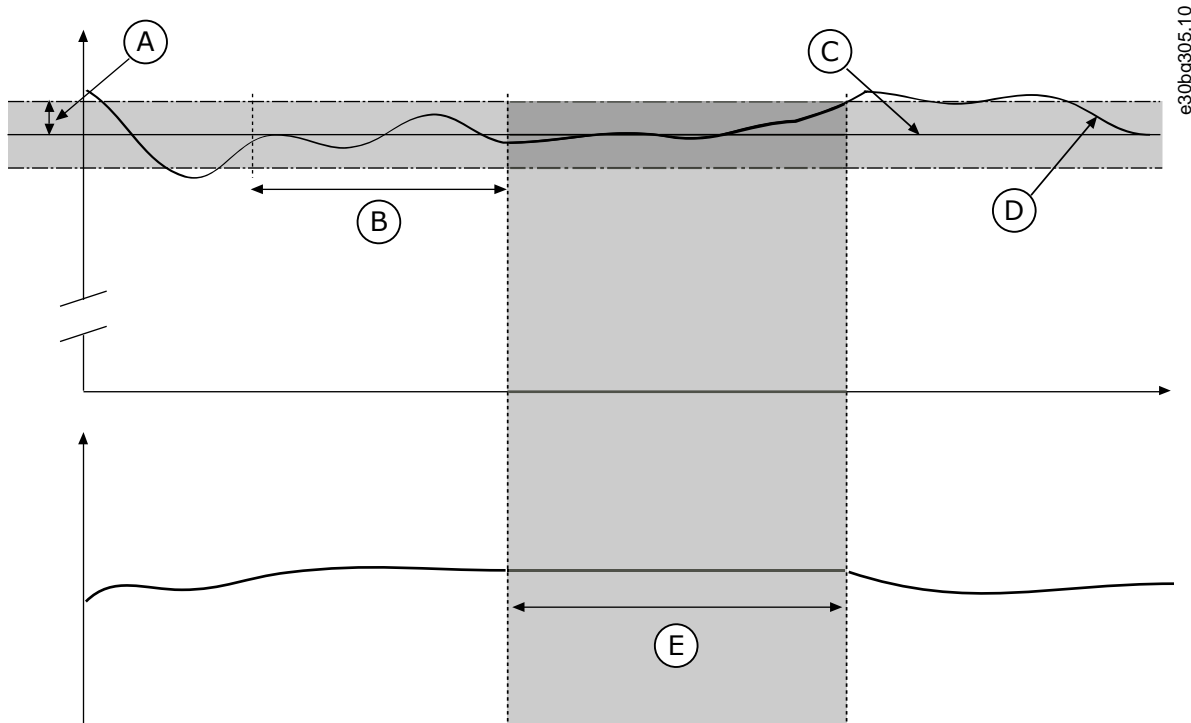

Illustration 76: The Dead Band Function

A	Dead band (ID1056)	D	Actual value
B	Dead band delay (ID1057)	E	Output locked
C	Reference		

11.15.2 Setpoints

11.15.2.1 (ID 167) Keypad Setpoint 1

Location in the menu: **P3.13.2.1**

Use this parameter to set the setpoint value of the PID controller when the setpoint source is 'Keypad SP'. The value of this parameter is given in the selected process unit.

11.15.2.2 (ID 168) Keypad Setpoint 2

Location in the menu: **P3.13.2.2**

Use this parameter to set the setpoint value of the PID controller when the setpoint source is 'Keypad SP'. The value of this parameter is given in the selected process unit.

11.15.2.3 (ID 1068) Setpoint Ramp Time

Location in the menu: **P3.13.2.3**

Use this parameter to set the rising and falling ramp times for the setpoint changes. Ramp time is the time that is necessary for the setpoint value to change from minimum to maximum. If the value of this parameter is set to 0, no ramps are used.

11.15.2.4 (ID 1046) PID Setpoint Boost Activation

Location in the menu: **P3.13.2.4**

Use this parameter to select the digital input signal that activates the boost for the PID setpoint value.

11.15.2.5 (ID 1047) PID Setpoint Selection

Location in the menu: **P3.13.2.5**

Use this parameter to set the digital input signal that selects the PID setpoint value to be used.

11.15.2.6 (ID 332) Setpoint Source 1 Selection

Location in the menu: **P3.13.2.6**

Use this parameter to select the source of the PID setpoint signal. The AIs and the ProcessDataIn are handled as percentages (0.00–100.00%) and scaled according to the setpoint minimum and maximum.

The ProcessDataIn signals use 2 decimals.

If temperature inputs are selected, the values of parameters P3.13.1.5 Process Unit Min and P3.13.1.6 Process Unit Max must be set to correspond to the scale of the temperature measurement board: ProcessUnitMin = -50 °C and ProcessUnitMax = 200 °C.

11.15.2.7 (ID 1069) Setpoint 1 Minimum

Location in the menu: **P3.13.2.7**

Use this parameter to set the minimum value of the setpoint signal.

11.15.2.8 (ID 1070) Setpoint 1 Maximum

Location in the menu: **P3.13.2.8**

Use this parameter to set the maximum value of the setpoint signal.

11.15.2.9 (ID 1071) Setpoint 1 Boost

Location in the menu: **P3.13.2.9**

Use this parameter to set the multiplier for the setpoint boost function. When the setpoint boost command is given, the setpoint value is multiplied by the factor that is set with this parameter.

11.15.3 Feedback

11.15.3.1 (ID 333) Feedback Function

Location in the menu: **P3.13.3.1**

Use this parameter to select if the feedback value is taken from a single signal or combined from two signals. It is possible to select the mathematical function that is used when the two feedback signals are combined.

11.15.3.2 (ID 1058) Feedback Function Gain

Location in the menu: **P3.13.3.2**

Use this parameter to adjust the gain of the feedback signal. This parameter is used, for example, with the value 2 in Feedback Function.

11.15.3.3 (ID 334) Feedback 1 Source Selection

Location in the menu: **P3.13.3.3**

Use this parameter to select the source of the PID feedback signal. The AIs and the ProcessDataIn are handled as percentages (0.00–100.00%) and scaled according to the feedback minimum and maximum.

The ProcessDataIn signals use 2 decimals.

If temperature inputs are selected, the values of parameters P3.13.1.5 Process Unit Min and P3.13.1.6 Process Unit Max must be set to correspond to the scale of the temperature measurement board: ProcessUnitMin = -50 °C and ProcessUnitMax = 200 °C.

11.15.3.4 (ID 336) Feedback 1 Minimum

Location in the menu: **P3.13.3.4**

Use this parameter to set the minimum value of the feedback signal.

11.15.3.5 (ID 337) Feedback 1 Maximum

Location in the menu: **P3.13.3.5**

Use this parameter to set the maximum value of the feedback signal.

11.15.4 Feedforward

11.15.4.1 (ID 1059) Feedforward Function

Location in the menu: **P3.13.4.1**

Use this parameter to select if the feedforward value is taken from a single signal or combined from two signals. It is possible to select the mathematical function that is used when the two feedforward signals are combined.

Accurate process models are necessary for the Feedforward function. In some conditions, a gain and offset type of feedforward is sufficient. The feedforward part does not use the feedback measurements of the actual controlled process value. The feedforward control uses other measurements that affect the controlled process value.

Example

It is possible to control the water level of a tank with flow control. The target water level is set as a setpoint, and the actual level as feedback. The control signal monitors the flow that comes in.

The outflow is like a disturbance that can be measured. With the measurements of the disturbance, it is possible to try to adjust this disturbance with a feedforward control (gain and offset) added to the PID output. The PID controller reacts much faster to changes in the outflow than if the level is only measured.

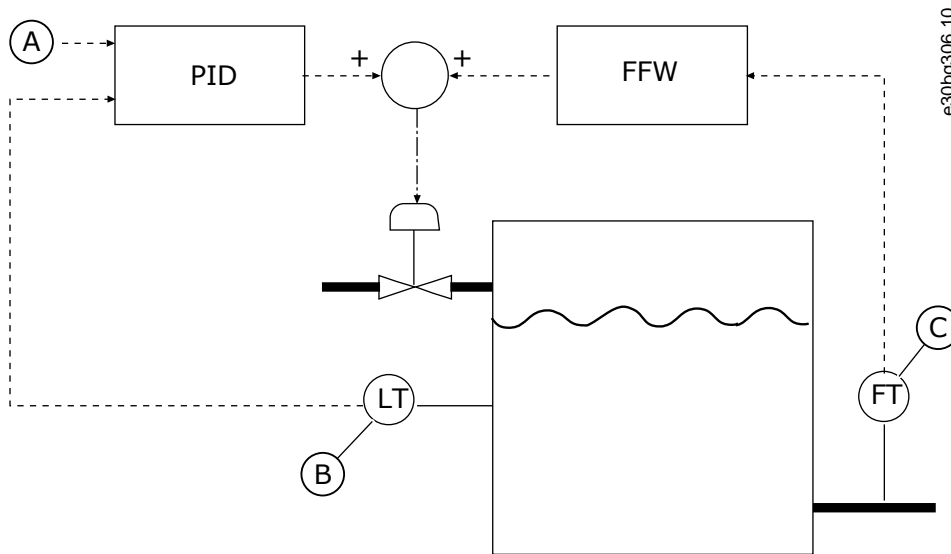

Illustration 77: The Feedforward Control

A	Level ref	C	Outflow control
B	Level control		

11.15.4.2 (ID 1060) Feedforward Gain

Location in the menu: **P3.13.4.2**

Use this parameter to adjust the gain of the feedforward signal.

11.15.4.3 (ID 1061) Feedforward 1 Source Selection

Location in the menu: **P3.13.4.3**

Use this parameter to select the source of the PID feedforward signal.

11.15.4.4 (ID 1062) Feedforward 1 Minimum

Location in the menu: **P3.13.4.4**

Use this parameter to set the minimum value of the feedforward signal.

11.15.4.5 (ID 1063) Feedforward 1 Maximum

Location in the menu: **P3.13.4.5**

Use this parameter to set the maximum value of the feedforward signal.

11.15.5 Sleep Function

11.15.5.1 (ID 1016) SP1 Sleep Frequency

Location in the menu: **P3.13.5.1**

Use this parameter to set the limit below which the output frequency of the drive must stay for a set time before the drive goes to the sleep state.

The value of this parameter is used when the signal of the PID controller setpoint is taken from the setpoint source 1.

Criteria for going to sleep mode:

- Output frequency remains below sleep frequency for longer than defined sleep delay time.
- PID feedback signal remains above defined wake-up level.

Criteria for waking from sleep

- PID feedback signal falls below defined wake-up level.

NOTICE

An incorrectly set wake-up level can prevent the drive from going into sleep mode.

11.15.5.2 (ID 1017) SP1 Sleep Delay

Location in the menu: **P3.13.5.2**

Use this parameter to set the minimum duration that the output frequency of the drive must stay below the set limit before the drive goes to the sleep state. The value of this parameter is used when the signal of the PID controller setpoint is taken from the setpoint source 1.

11.15.5.3 (ID 1018) SP1 Wake-Up Level

Location in the menu: **P3.13.5.3**

Use this parameter to set the level at which the drive wakes up from the sleep state. When the PID feedback value goes below the level that is set with this parameter, drive wakes up from the sleep state. The operation of this parameter is selected with wake-up mode parameter.

11.15.5.4 (ID 1019) SP1 Wake-Up Mode

Location in the menu: **P3.13.5.4**

Use this parameter to select the operation for the wake-up level parameter. The drive wakes up from the sleep mode when the value of PID Feedback goes below the Wake-up level.

This parameter defines if Wake-up level is used as a static absolute level or as a relative level which follows PID setpoint value.

Selection number	Selection name	Description
0	Absolute level	The wake-up level is a static level that does not follow the setpoint value.
1	Relative setpoint	The wake-up level is an offset below the actual setpoint value. The wake-up level follows the actual setpoint.

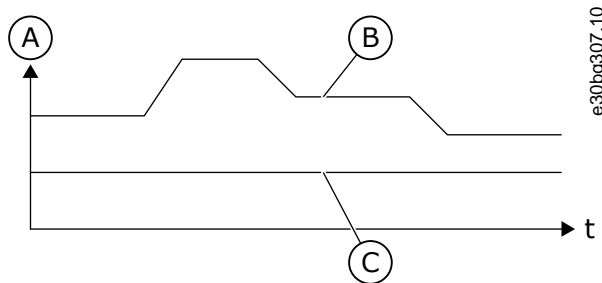

Illustration 78: Wake-up Mode: Absolute Level

A	Setpoint	C	Wake-up level
B	PID Setpoint		

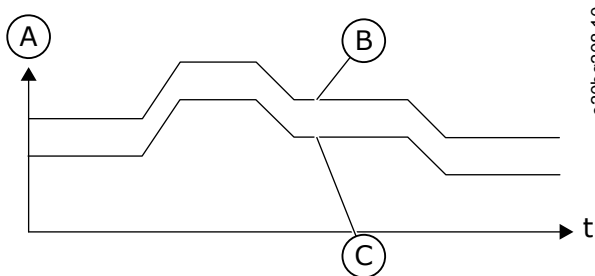

Illustration 79: Wake-up Mode: Relative Setpoint

A	Setpoint	C	Wake-up level
B	PID Setpoint		

11.15.5.5 (ID 1793) SP1 Sleep Boost

Location in the menu: **P3.13.5.5**

Use this parameter to set the value that is added to the actual setpoint value when the sleep boost function is used. Before the drive goes to the sleep state, the PID regulation setpoint increases automatically, which gives a higher process value. The sleep state is longer, also when there is some moderate leakage.

The boost level is used when there is a frequency threshold and delay, and the drive goes to the sleep state. After the increment in the setpoint by the actual value, the boost increment of the setpoint is erased and the drive goes to the sleep state and the motor stops. The boost increment is positive with the direct PID regulation (P3.13.1.8 = Normal) and negative with the reverse PID regulation (P3.13.1.8 = Inverted).

If the actual value does not go to the increment setpoint, the boost value is erased after the time set with P3.13.5.5. The drive goes to the normal regulation with the normal setpoint.

In a Multi-pump setup, if an auxiliary pump starts during the boost, the boost sequence stops and the normal regulation continues.

11.15.5.6 (ID 1795) SP1 Sleep Boost Maximum Time

Location in the menu: **P3.13.5.6**

Use this parameter to set the timeout time for the sleep boost function.

11.15.5.7 (ID 1075) SP2 Sleep Frequency

Location in the menu: **P3.13.5.5**

Use this parameter to set the limit below which the output frequency of the drive must stay for a set time before the drive goes to the sleep state.

The value of this parameter is used when the signal of the PID controller setpoint is taken from the setpoint source 1.

Criteria for going to sleep mode:

- Output frequency remains below sleep frequency for longer than defined sleep delay time.
- PID feedback signal remains above defined wake-up level.

Criteria for waking from sleep

- PID feedback signal falls below defined wake-up level.

N O T I C E

An incorrectly set wake-up level can prevent the drive from going into sleep mode.

11.15.5.8 (ID 1076) SP2 Sleep Delay

Location in the menu: **P3.13.5.6**

Use this parameter to set the minimum duration that the output frequency of the drive must stay below the set limit before the drive goes to the sleep state. The value of this parameter is used when the signal of the PID controller setpoint is taken from the setpoint source 1.

11.15.5.9 (ID 1077) SP2 Wake-Up Level

Location in the menu: **P3.13.5.7**

Use this parameter to set the level at which the drive wakes up from the sleep state. When the PID feedback value goes below the level that is set with this parameter, drive wakes up from the sleep state. The operation of this parameter is selected with wake-up mode parameter.

11.15.5.10 (ID 1020) SP2 Wake-Up Mode

Location in the menu: **P3.13.5.8**

Use this parameter to select the operation for the wake-up level parameter. The drive wakes up from the sleep mode when the value of PID Feedback goes below the Wake-up level.

This parameter defines if Wake-up level is used as a static absolute level or as a relative level which follows PID setpoint value.

Selection number	Selection name	Description
0	Absolute level	The wake-up level is a static level that does not follow the setpoint value.
1	Relative setpoint	The wake-up level is an offset below the actual setpoint value. The wake-up level follows the actual setpoint.

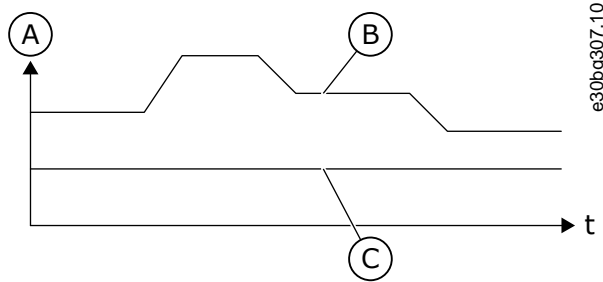

Illustration 80: Wake-up Mode: Absolute Level

A	Setpoint	C	Wake-up level
B	PID Setpoint		

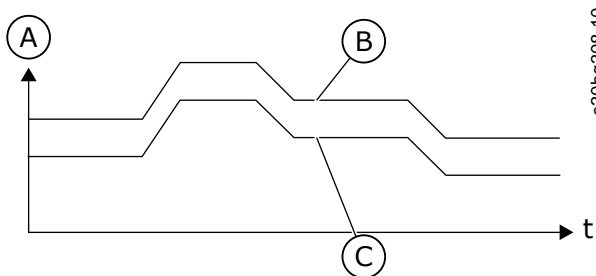

Illustration 81: Wake-up Mode: Relative Setpoint

A	Setpoint	C	Wake-up level
B	PID Setpoint		

11.15.5.11 (ID 1794) SP2 Sleep Boost

Location in the menu: **P3.13.5.11**

Use this parameter to set the value that is added to the actual setpoint value when the sleep boost function is used.

11.15.5.12 (ID 1796) SP2 Sleep Boost Maximum Time

Location in the menu: **P3.13.5.12**

Use this parameter to set the timeout time for the sleep boost function.

11.15.6 Feedback Supervision

Use the feedback supervision to make sure that the PID Feedback value (the process value or the actual value) stays in the set limits. Use this function, for example, to find a pipe break and stop the flooding.

These parameters set the range in which the PID Feedback signal stays in correct conditions. If the PID Feedback signal does not stay in the range, and this continues longer than the delay, a Feedback supervision fault (the fault code 101) shows.

11.15.6.1 (ID 735) Enable Feedback Supervision

Location in the menu: **P3.13.6.1**

Use this parameter to enable the feedback supervision function. Use the feedback supervision to make sure that the PID feedback value stays in the set limits.

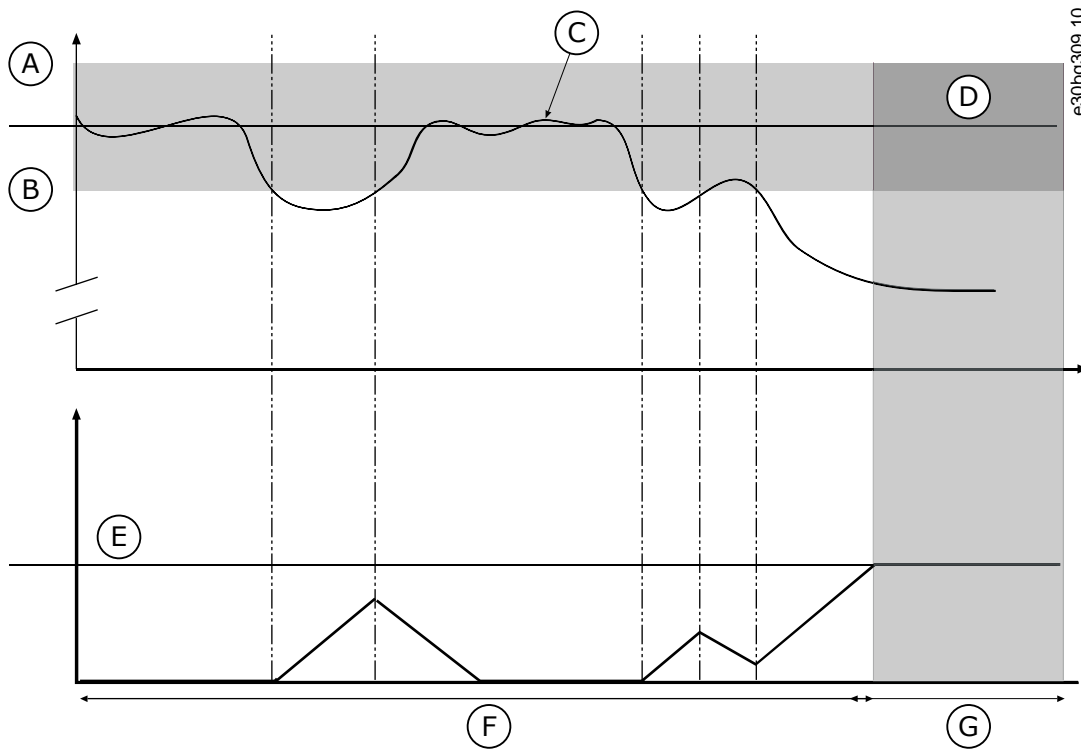

Illustration 82: The Feedback Supervision Function

A	Upper limit (ID 736)	E	Delay (ID 737)
B	Lower limit (ID 758)	F	Regulating mode
C	Actual value	G	Alarm or fault
D	Reference		

11.15.6.2 (ID 736) Upper Limit

Location in the menu: **P3.13.6.2**

Use this parameter to set the high limit for the PID feedback signal. If the value of the PID feedback signal goes above this limit for longer than the set time, a feedback supervision fault occurs.

11.15.6.3 (ID 758) Lower Limit

Location in the menu: **P3.13.6.3**

Use this parameter to set the low limit for the PID feedback signal. If the value of the PID feedback signal goes below this limit for longer than the set time, a feedback supervision fault occurs.

Set the upper limit and the lower limit around the reference. When the actual value is less or more than the limits, a counter starts to count up. When the actual value is between the limits, the counter counts down. When the counter gets a value that is higher than the value of P3.13.6.4 Delay, an alarm, or a fault shows. It is possible to select the response with parameter P3.13.6.5 (Response to PID1 Supervision Fault).

11.15.6.4 (ID 737) Delay

Location in the menu: **P3.13.6.4**

Use this parameter to set the maximum time for the PID feedback signal to stay outside the supervision limits before the feedback supervision fault occurs. If the target value is not reached in this time, a fault or alarm shows.

11.15.6.5 (ID 749) Response to PID Supervision Fault

Location in the menu: **P3.13.6.5**

Use this parameter to select the response of the drive to a 'PID Supervision' fault. If the PID feedback value is not in the supervision limits for longer than the supervision delay, a PID supervision fault occurs.

11.15.7 Pressure Loss Compensation

When pressurizing a long pipe that has many outlets, the best position for the sensor is in the middle of the pipe (the position 2 in the figure). It is also possible to put the sensor directly after the pump. This gives the right pressure directly after the pump, but farther in the pipe, the pressure drops with the flow.

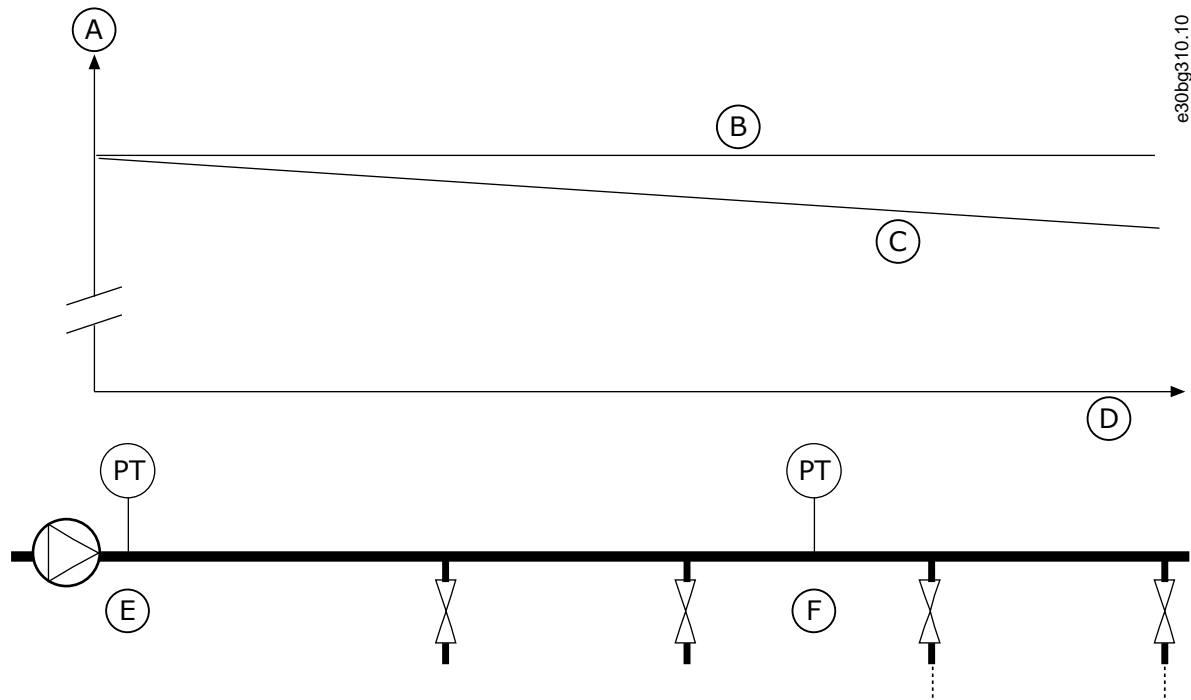

Illustration 83: The Position of the Pressure Sensor

A	Pressure	D	Pipe length
B	No flow	E	Position 1
C	With flow	F	Position 2

11.15.7.1 (ID 1189) Enable Setpoint 1

Location in the menu: **P3.13.7.1**

Use this parameter to enable the pressure loss compensation in the pump system. In a pressure-controlled system, this function compensates the pressure loss that occurs at the end of the pipe line due to the liquid flow.

11.15.7.2 (ID 1190) Setpoint 1 Max Compensation

Location in the menu: **P3.13.7.2**

Use this parameter to set the maximum compensation for PID setpoint value that is applied when the output frequency of the drive is at the maximum frequency. The compensation value is added to the actual setpoint value as a function of the output frequency. $\text{Setpoint compensation} = \text{max compensation} * (\text{FreqOut} - \text{MinFreq}) / (\text{MaxFreq} - \text{MinFreq})$.

The sensor is put in position 1. The pressure in the pipe stays constant when there is no flow. But with flow, the pressure decreases farther in the pipe. To compensate for this, lift the setpoint as the flow increases. Then the output frequency makes an estimate of the flow, and the setpoint increases linearly with the flow.

e30bg311.10

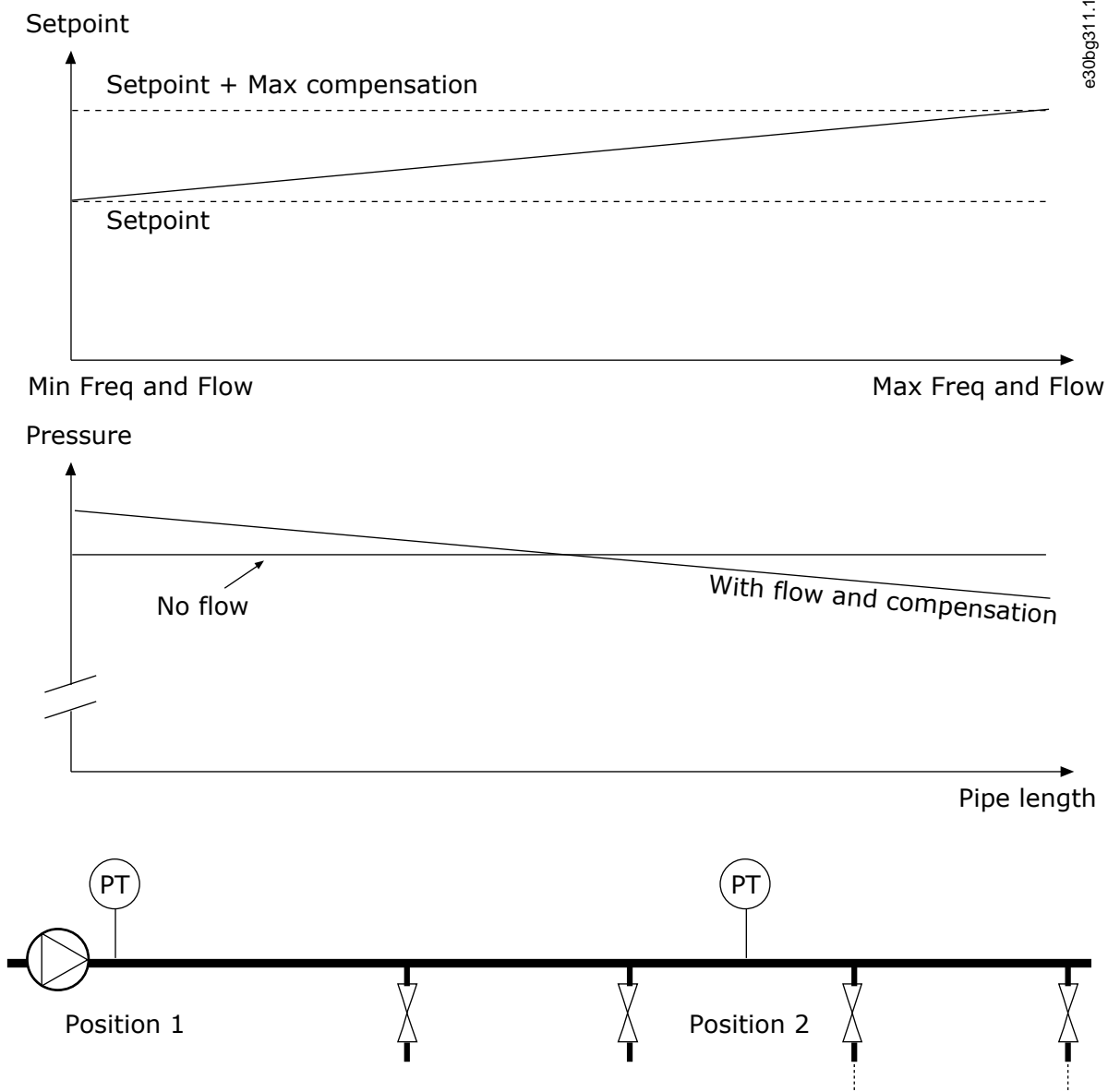

Illustration 84: Enable Setpoint 1 for Pressure Loss Compensation

11.15.8 Soft Fill

The Soft fill function is used to move the process to a set level at a slow speed before the PID controller starts to control. If the process does not go to the set level during the timeout, a fault shows.

It is possible to use the function to fill an empty pipe slowly and prevent strong currents of water that could break the pipe.

We recommend always using the Soft fill function when using the Multi-pump function.

11.15.8.1 (ID 1094) Soft Fill Function

Location in the menu: **P3.13.8.1**

Use this parameter to enable the Soft Fill function. It is possible to use the function to fill an empty pipe slowly and prevent strong currents of fluid that could break the pipe.

Selection number	Selection name	Description
0	Disabled	
1	Enabled (Level)	The drive operates at a constant frequency (P3.13.8.2 Soft Fill Frequency) until the PID feedback signal goes to the soft fill level (P3.13.8.3 Soft Fill Level). The PID controller starts the regulation. In addition, if the PID feedback signal does not go to the soft fill level in the soft fill timeout (P3.13.8.4 Soft Fill Timeout), a soft fill fault is shown (P3.13.8.4 Soft Fill Timeout is set to greater than 0). The soft fill mode is used in vertical installations.
2	Enabled (Timeout)	The drive operates at a constant frequency (P3.13.8.2 Soft Fill Frequency) until the soft fill time (P3.13.8.4 Soft Fill Timeout) goes. After the soft fill time, the PID controller starts the regulation. In this mode, the soft fill fault is not available. The soft fill mode is used in horizontal installations.

11.15.8.2 (ID 1055) Soft Fill Frequency

Location in the menu: **P3.13.8.2**

Use this parameter to set the frequency reference of the drive when the Soft Fill function is used.

11.15.8.3 (ID 1095) Soft Fill Level

Location in the menu: **P3.13.8.3**

Use this parameter to set the level below which the soft fill control is enabled when starting the drive. The drive operates at the PID start frequency until the feedback reaches the set value. Then the PID controller starts to control the drive. This parameter is applied if the soft fill function is set to 'Enabled, Level'.

11.15.8.4 (ID 1096) Soft Fill Timeout

Location in the menu: **P3.13.8.4**

Use this parameter to set the timeout time for the Soft Fill function. When the soft fill function is set to 'Enabled, Level', this parameter gives the timeout for the soft fill level, after which the soft fill fault occurs. When the soft fill function is set to 'Enabled, Timeout', the drive operates at the soft fill frequency until the time set by this parameter expires.

If the option Enabled (Timeout) is selected in parameter P3.13.8.1 Soft Fill Function, parameter Soft Fill Timeout gives the quantity of time that the drive operates at the constant soft fill frequency (P3.13.8.2 Soft Fill Frequency) before the PID controller starts the regulation.

11.15.8.5 (ID 748) Soft Fill Fault

Location in the menu: **P3.13.8.5**

Use this parameter to select the response of the drive to a 'PID Soft Fill' fault. If the PIDFeedback value does not reach the set level in the time limit, a soft fill fault occurs.

Selection number	Selection name	Description
0	No action	
1	Alarm	
2	Fault (stop according to stop mode)	
3	Fault (stop by coasting)	

11.15.9 Input Pressure Supervision

Use the Input pressure supervision to make sure that there is enough water in the inlet of the pump. When there is enough water, the pump does not suck air and there is no suction cavitation. To use the function, install a pressure sensor on the pump inlet.

If the input pressure of the pump goes below the set alarm limit, an alarm shows. The setpoint value of the PID controller decreases and causes the output pressure of the pump to decrease. If the pressure goes below the fault limit, the pump is stops and a fault shows.

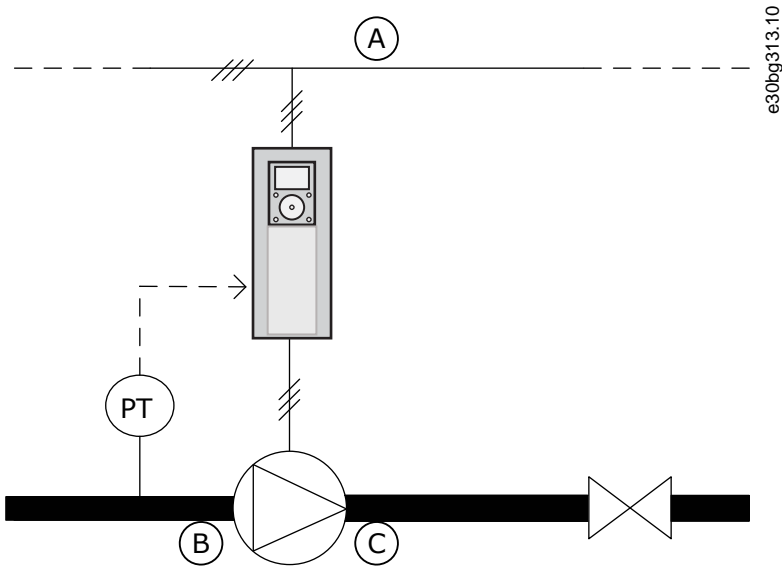

Illustration 85: The Location of the Pressure Sensor

A	Mains	C	Outlet
B	Inlet		

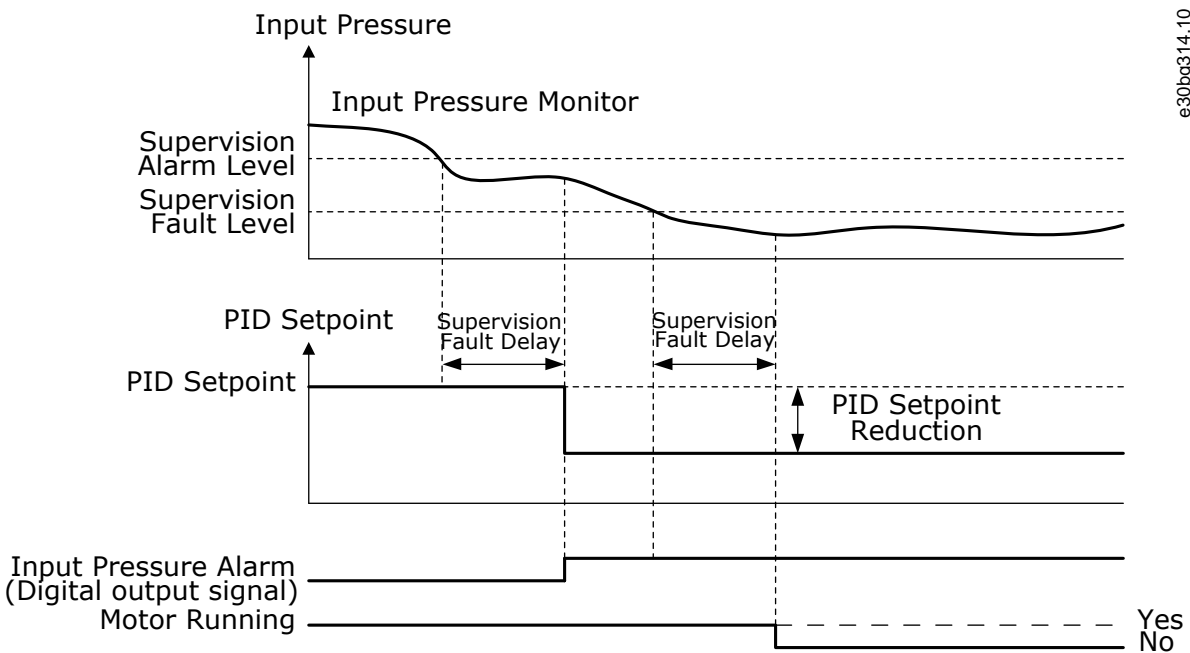

Illustration 86: The Input Pressure Supervision Function

11.15.9.1 (ID 1685) Enable Supervision

Location in the menu: **P3.13.9.1**

Use this parameter to enable the Input Pressure Supervision function. Use this function to make sure that there is enough fluid in the inlet of the pump.

11.15.9.2 (ID 1686) Supervision Signal

Location in the menu: **P3.13.9.2**

Use this parameter to select the source of the input pressure signal.

11.15.9.3 (ID 1687) Supervision Unit Selection

Location in the menu: **P3.13.9.3**

Use this parameter to select the unit for the input pressure signal. It is possible to scale the supervision signal (P3.13.9.2) to process units on the panel.

11.15.9.4 (ID 1688) Supervision Unit Decimals

Location in the menu: **P3.13.9.4**

Use this parameter to set the number of decimals for the input pressure signal unit. It is possible to scale the supervision signal (P3.13.9.2) to process units on the panel.

11.15.9.5 (ID 1689) Supervision Unit Minimum Value

Location in the menu: **P3.13.9.5**

Use this parameter to set the minimum value of the input pressure signal. Enter the value in the selected process unit. For example, an analog signal of 4...20 mA corresponds to the pressure of 0...10 bar.

11.15.9.6 (ID 1690) Supervision Unit Maximum Value

Location in the menu: **P3.13.9.6**

Use this parameter to set the maximum value of the input pressure signal. Enter the value in the selected process unit. For example, an analog signal of 4...20 mA corresponds to the pressure of 0...10 bar.

11.15.9.7 (ID 1691) Supervision Alarm Level

Location in the menu: **P3.13.9.7**

Use this parameter to set the limit for the input pressure alarm. If the measured input pressure goes below this limit, an input pressure alarm occurs.

11.15.9.8 (ID 1692) Supervision Fault Level

Location in the menu: **P3.13.9.8**

Use this parameter to set the limit for the input pressure fault. If the measured input pressure stays below this level for longer than the set time, an input pressure fault occurs.

11.15.9.9 (ID 1693) Supervision Fault Delay

Location in the menu: **P3.13.9.9**

Use this parameter to set the maximum duration for the input pressure to stay below the fault limit before an input pressure fault occurs.

11.15.9.10 (ID 1694) PID Setpoint Reduction

Location in the menu: **P3.13.9.10**

Use this parameter to set the rate of the reduction of the PID setpoint value when the measured input pressure is below the alarm limit.

11.15.9.11 (ID 1407) Setpoint Reduction Interpolation Source

Location in the menu: **P3.13.9.11**

Use this parameter to select source for setpoint reduction interpolation or disable it. This function compares selection to input pressure alarm and fault levels and accordingly adjusts setpoint reduction between 0 and setpoint reduction parameter. If disabled setpoint reduction will be equal to setpoint reduction parameter.

Selection number	Selection name	Description
0	Feedback	The setpoint reduction size is adjusted according to the PID feedback signal
1	Input pressure monitor	The setpoint reduction size is adjusted according to the Input pressure monitor value
2	Disabled	The setpoint reduction size is always equal to the parameter value

11.15.10 Sleep Function When No Demand Is Detected

This function makes sure that the pump does not operate at a high speed when there is no demand in the system.

The function becomes active when the PID feedback signal and the output frequency of the drive stay in the specified hysteresis areas for longer than set with parameter P3.13.10.4 SNDD Supervision Time.

There are different hysteresis settings for the PID feedback signal and the output frequency. The hysteresis for the PID feedback (SNDD Error Hysteresis P3.13.10.2) is given in the selected process units around the PID setpoint value.

When the function is active, a short-time bias value (SNDD Actual Add) is added internally to the feedback value.

- If there is no demand in the system, the PID output, and the output frequency of the drive decrease to the direction of 0. If the PID feedback value stays in the hysteresis area, the drive goes to the Sleep mode.
- If the PID feedback value does not stay in the hysteresis area, the function is deactivated and the drive continues to operate.

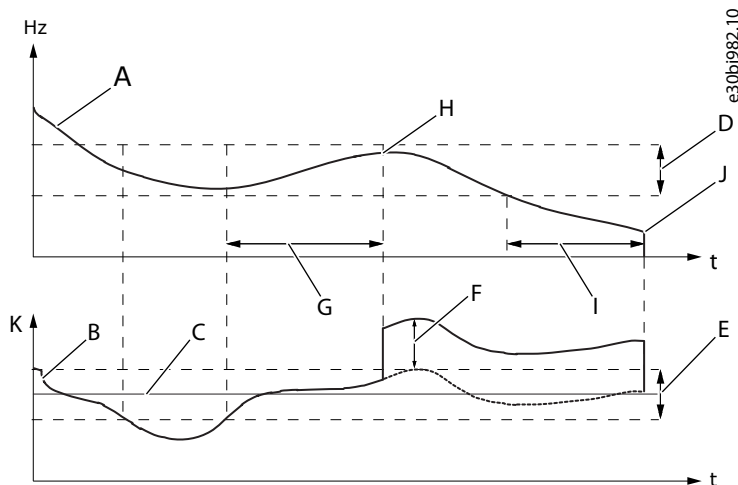

Illustration 87: Sleep, No Demand Detected

A	The output frequency of the drive	G	SNDD Supervision Time (P3.13.10.4)
B	The PID feedback value	H	The PID feedback value and the output frequency of the drive are in the hysteresis areas for the set time (SNDD Supervision Time). A bias value (SNDD Actual Add) is added to the PID feedback value.
C	The PID setpoint value	I	SP1 Sleep Delay Time (P3.13.5.2)
D	SNDD Frequency Hysteresis (P3.13.10.3)	J	The drive goes to the Sleep mode.
E	SNDD Error Hysteresis (P3.13.10.2) The hysteresis area around the PID setpoint value.	K	Process Unit (P3.13.1.4)
F	SNDD Actual Add (P3.13.10.5)		

11.15.10.1 (ID 1649) Sleep No Demand Detection Enable

Location in the menu: **P3.13.10.1**

Use this parameter to activate the Sleep No Demand Detection (SNDD) function.

11.15.10.2 (ID 1658) SNDD Error Hysteresis

Location in the menu: **P3.13.10.2**

Use this parameter to set the hysteresis for the error value of the PID controller.

11.15.10.3 (ID 1663) SNDD Frequency Hysteresis

Location in the menu: **P3.13.10.3**

Use this parameter to set the hysteresis for the output frequency of the drive.

11.15.10.4 (ID 1668) SNDD Supervision Time

Location in the menu: **P3.13.10.4**

Use this parameter to set the time that the output frequency of the drive and the error value of the PID controller must stay in the hysteresis areas before the SNDD function becomes active.

11.15.10.5 (ID 1669) SNND Actual Add

Location in the menu: **P3.13.10.5**

Use this parameter to set the value that is added to the actual value of the PID feedback for a short time when the SNDD function is active.

11.15.11 Multi-setpoint

11.15.11.1 (ID 15560) Multi-setpoint 0

Location in the menu: **P3.13.12.1**

Use this parameter to set the preset PID setpoint value when the Multi-setpoint function is used. Make the selection of the multi-setpoint with the digital input signals.

11.15.11.2 (ID 15561) Multi-setpoint 1

Location in the menu: **P3.13.12.2**

Use this parameter to set the preset PID setpoint value when the Multi-setpoint function is used. Make the selection of the multi-setpoint with the digital input signals.

11.15.11.3 (ID 15562) Multi-setpoint 2

Location in the menu: **P3.13.12.3**

Use this parameter to set the preset PID setpoint value when the Multi-setpoint function is used. Make the selection of the multi-setpoint with the digital input signals.

11.15.11.4 (ID 15563) Multi-setpoint 3

Location in the menu: **P3.13.12.4**

Use this parameter to set the preset PID setpoint value when the Multi-setpoint function is used. Make the selection of the multi-setpoint with the digital input signals.

11.15.11.5 (ID 15564) Multi-setpoint 4

Location in the menu: **P3.13.12.5**

Use this parameter to set the preset PID setpoint value when the Multi-setpoint function is used. Make the selection of the multi-setpoint with the digital input signals.

11.15.11.6 (ID 15565) Multi-setpoint 5

Location in the menu: **P3.13.12.6**

Use this parameter to set the preset PID setpoint value when the Multi-setpoint function is used. Make the selection of the multi-setpoint with the digital input signals.

11.15.11.7 (ID 15566) Multi-setpoint 6

Location in the menu: **P3.13.12.7**

Use this parameter to set the preset PID setpoint value when the Multi-setpoint function is used. Make the selection of the multi-setpoint with the digital input signals.

11.15.11.8 (ID 15567) Multi-setpoint 7

Location in the menu: **P3.13.12.8**

Use this parameter to set the preset PID setpoint value when the Multi-setpoint function is used. Make the selection of the multi-setpoint with the digital input signals.

11.15.11.9 (ID 15569) Multi-setpoint 9

Location in the menu: **P3.13.12.10**

Use this parameter to set the preset PID setpoint value when the Multi-setpoint function is used. Make the selection of the multi-setpoint with the digital input signals.

11.15.11.10 (ID 15570) Multi-setpoint 10

Location in the menu: **P3.13.12.11**

Use this parameter to set the preset PID setpoint value when the Multi-setpoint function is used. Make the selection of the multi-setpoint with the digital input signals.

11.15.11.11 (ID 15571) Multi-setpoint 11

Location in the menu: **P3.13.12.11**

Use this parameter to set the preset PID setpoint value when the Multi-setpoint function is used. Make the selection of the multi-setpoint with the digital input signals.

11.15.11.12 (ID 15572) Multi-setpoint 12

Location in the menu: **P3.13.12.13**

Use this parameter to set the preset PID setpoint value when the Multi-setpoint function is used. Make the selection of the multi-setpoint with the digital input signals.

11.15.11.13 (ID 15573) Multi-setpoint 13

Location in the menu: **P3.13.12.13**

Use this parameter to set the preset PID setpoint value when the Multi-setpoint function is used. Make the selection of the multi-setpoint with the digital input signals.

11.15.11.14 (ID 15574) Multi-setpoint 14

Location in the menu: **P3.13.12.15**

Use this parameter to set the preset PID setpoint value when the Multi-setpoint function is used. Make the selection of the multi-setpoint with the digital input signals.

11.15.11.15 (ID 15575) Multi-setpoint 15

Location in the menu: **P3.13.12.16**

Use this parameter to set the preset PID setpoint value when the Multi-setpoint function is used. Make the selection of the multi-setpoint with the digital input signals.

11.15.11.16 (ID 15576) Multi-setpoint Selection 0

Location in the menu: **P3.13.12.17**

Use this parameter to select the digital input signal that is used as a selector for the PID Multi-setpoint function.

11.15.11.17 (ID 15577) Multi-setpoint Selection 1

Location in the menu: **P3.13.12.18**

Use this parameter to select the digital input signal that is used as a selector for the PID Multi-setpoint function.

11.15.11.18 (ID 15578) Multi-setpoint Selection 2

Location in the menu: **P3.13.12.19**

Use this parameter to select the digital input signal that is used as a selector for the PID Multi-setpoint function.

11.15.11.19 (ID 15579) Multi-setpoint Selection 3

Location in the menu: **P3.13.12.20**

Use this parameter to select the digital input signal that is used as a selector for the PID Multi-setpoint function.

11.16 External PID Controller

11.16.1 (ID 1630) Enable External PID

Location in the menu: **P3.14.1.1**

Use this parameter to enable the PID controller.

This controller is for external use only. It can be used with an analog output.

11.16.2 (ID 1049) Start Signal

Location in the menu: **P3.14.1.2**

Use this parameter to set the signal for starting and stopping the PID controller 2 for external usage.

If the PID2 controller is not enabled in the Basic menu for PID2, this parameter has no effect.

11.17 Multi-pump Function

11.17.1 The Multi-pump Function

The Multi-pump function allows controlling a system where the maximum of 8 motors, for example, pumps, fans or compressors operate in parallel. The internal PID controller of the drive operates the necessary quantity of motors and controls the speed of the motors, when there is demand.

11.17.1.1 Commissioning Multi-pump (Multidrive)

The check list helps in the configuration of the basic settings of the Multi-pump (multidrive) system. If the keypad is used for parameterization, the application wizard helps to make the basic settings.

Start the commissioning with the drives that have the PID feedback signal (pressure sensor, for example) connected to an analog input (default: AI2). Go through all the drives in the system.

Procedure

1. Examine the wiring.

- See the correct power cabling (mains cable, motor cable) of the drive in Installation Guide.
- See the correct control cabling (I/O, PID feedback sensor, communication) in [Illustration 20](#) and in [Illustration 18](#).
- If redundancy is necessary, make sure that the PID feedback signal (by default: AI2) is connected to a minimum of 2 drives. See the wiring instructions in [Illustration 20](#).

2. Do a power-up of the drive and start the parameterization.

- Start the parameterization with the drives that have the PID feedback signal connected. These drives can operate as the master of the Multi-pump system.
- Parameterization can be done with the keypad or PC the tool.

3. Select the Multi-pump (multidrive) application configuration with parameter P1.2.

- Most of the Multi-pump-related settings and configurations are made automatically, when the Multi-pump (multi-drive) application is selected with parameter P1.2 Application (ID 212). See [4.1.5 Multi-pump \(Multidrive\) Application Wizard](#).
- If the keypad is used for the parameterization, the Application wizard starts when parameter P1.2 Application (ID 212) is changed. The Application wizard helps with Multipump-related questions.

4. Set the motor parameters.

- Set the motor nameplate parameters specified by the nameplate of the motor.

5. Set the total number of drives used in the Multi-pump system.

- This value is set with parameter P1.35.14 Quick Setup Parameter Menu.
- The same parameter is in the menu Parameters -> Group 3.15 -> P3.15.2.
- By default, the Multi-pump system has 3 pumps (drives).

6. Select the signals that are connected to the drive.

- Go to parameter P1.35.16 (Quick Setup Parameter Menu).
- The same parameter is in the menu Parameters -> Group 3.15 -> P3.15.4.
- If the PID feedback signal is connected, the drive can operate as the master of the Multi-pump system. If the signal is not connected, the drive operates as a slave unit.

- Select Signals connected, if the start and the PID feedback signals (the pressure sensor, for example) are connected to the drive.
- Select Start signal only, if only the start signal is connected to the drive (the PID feedback signal is not connected).
- Select Not connected, if the start or the PID feedback signals are not connected to the drive.

7. Set the ID number of the pump.

- Go to parameter P1.35.15 (Quick Setup Parameter Menu).
- The same parameter is in the menu Parameters -> Group 3.15 -> P3.15.3.
- Each drive in the Multi-pump system must have an ID number that no other drive has for the correct communication between drives. The ID numbers must be in a numerical order and start from number 1.
- The drives, which have a PID feedback signal connected, have the smallest ID numbers (for example, ID 1 and ID 2). It gives the shortest possible start-up delay when doing a power-up of the system.

8. Configure the Interlock function.

- Go to parameter P1.35.17 (Quick Setup Parameter Menu).
- The same parameter is in menu Parameters -> Group 3.15 -> P3.15.5.
- By default, the interlock function is disabled.
- Select Enabled, if the interlock signal is connected to the digital input DI5 of the drive. The interlock signal is the digital input signal that tells if this pump is available in the Multi-pump system.
- Select Not Used, if the interlock signal is not connected to the digital input DI5 of the drive. The system sees that all the pumps in the Multi-pump system are available.

9. Examine the source of the PID setpoint signal.

- By default, the PID setpoint value comes from parameter P1.35.9 Keypad Setpoint 1.
- If necessary, change the source of the PID setpoint signal with parameter P1.35.8. Select the analog input or Fieldbus Process Data In 1–8, for example.

The basic settings of the Multi-pump system are completed. Use the check list also when configuring the next drives in the system.

11.17.2 System Configuration

11.17.2.1 Single Drive Configuration

The Single drive mode controls a system of 1 variable speed pump and the maximum of 7 auxiliary pumps. The internal PID controller of the drive controls the speed of 1 pump and gives control signals with relay outputs to start or stop the auxiliary pumps. External contactors are necessary for the switch of the auxiliary pumps to the mains.

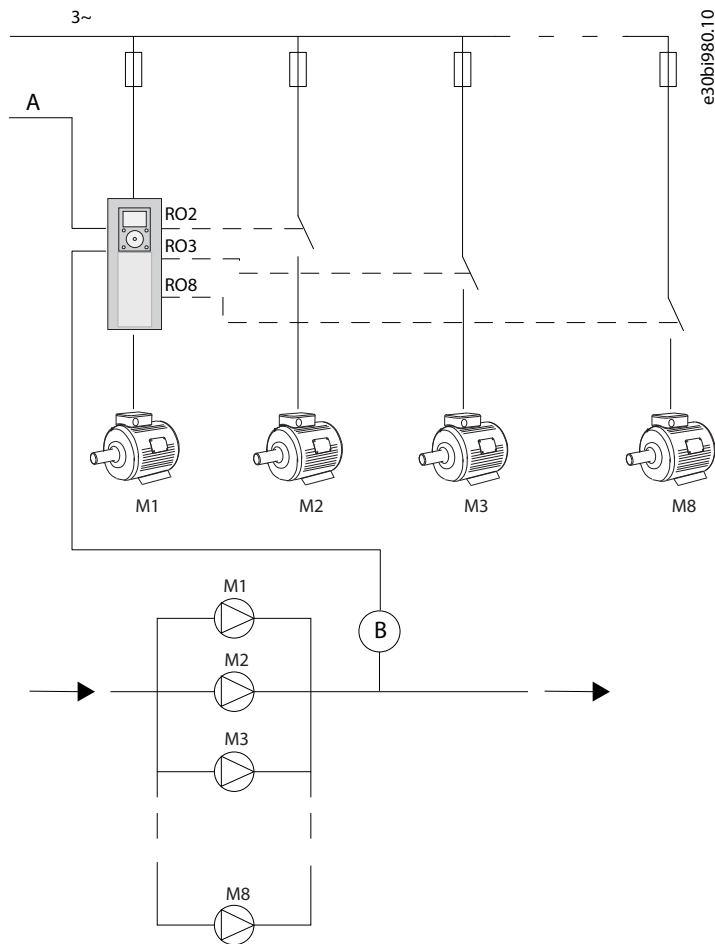

Illustration 88: Single Drive Configuration

A	Start / Stop
B	Pressure sensor

11.17.2.2 Multidrive Configuration

The Multidrive modes (Multimaster and Multifollower) control a system that has the maximum 8 variable speed pumps. Each pump is controlled by a drive. The internal PID controller of the drive controls all pumps. The drives use a communication bus (Modbus RTU) for communication.

The figure shows the Multidrive configuration principle. See also the general electric diagram of a Multi-pump system in [Illustration 20](#).

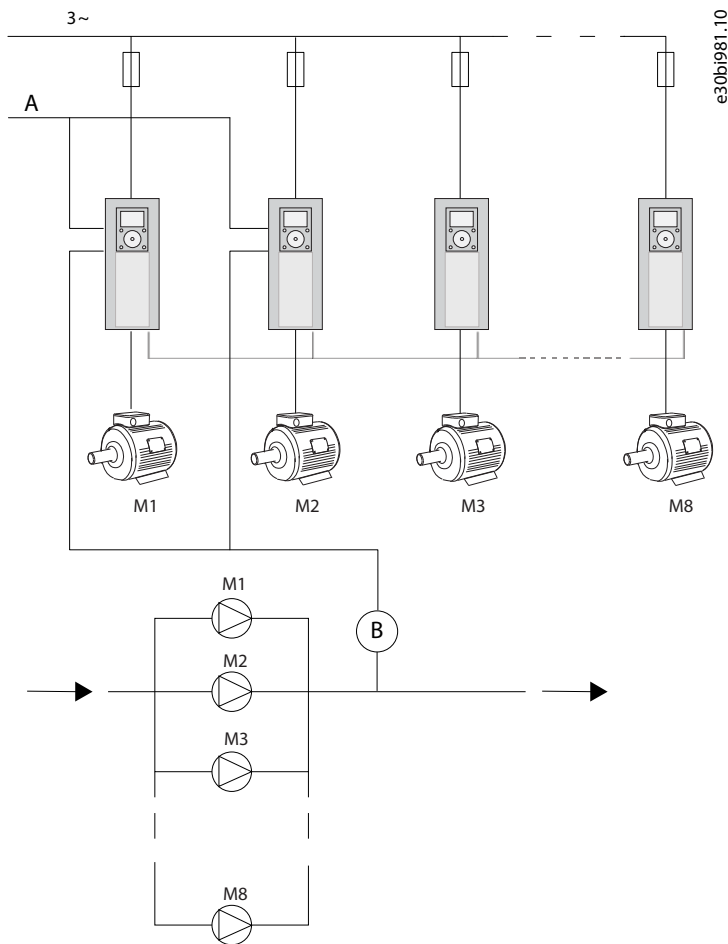

Illustration 89: Multidrive Configuration

A	Start / Stop
B	Pressure sensor

11.17.2.3 (ID 1785) Multi-pump Mode

Location in the menu: **P3.15.1**

Use this parameter to select the configuration and the control mode of the Multi-pump system. The Multi-pump function allows controlling a maximum of 8 motors (that is, pumps, fans, compressors) with the PID control.

0 = Single drive

The Single drive mode controls a system that has 1 pump that can change speed and the maximum of 7 auxiliary pumps. The internal PID controller of the drive controls the speed of 1 pump and gives control signals with relay outputs to start or stop the auxiliary pumps.

External contactors are necessary for the switch of the auxiliary pumps to the mains. 1 of the pumps is connected to the drive and controls the system. When the pump in control sees that it is necessary to have more capacity (operates at the maximum frequency), the drive gives the control signal with the relay output to start the next auxiliary pump. When the auxiliary pump starts, the pump in control continues to control and starts from the minimum frequency.

When the pump that controls the system sees that there is too much capacity (operates at the minimum frequency), the pump makes the started auxiliary pump to stop. If no auxiliary pumps operate when the pump in control sees the overcapacity, the pump goes to the Sleep mode (if the Sleep function is enabled).

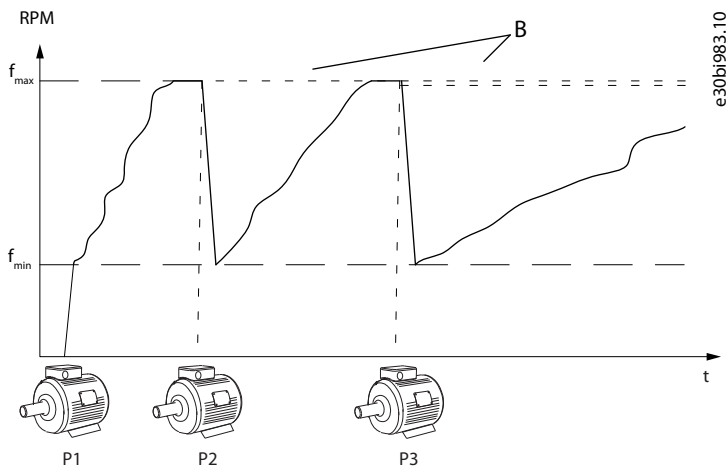

Illustration 90: Control in the Single Drive Mode

P1	The pump that controls the system
B	The auxiliary pumps connected to the mains (direct on-line)

1 = Multifollower

The Multifollower mode controls a system that has the maximum 8 pumps that can change speed. Each pump is controlled by a drive. The internal PID controller of the drive controls all the pumps.

1 of the pumps always controls the system. When the pump in control sees that it is necessary to have more capacity (operates at the maximum frequency), the pump uses the communication bus to make the next pump to start. The next pump increases speed and starts to operate at the speed of the pump in control. Auxiliary pumps operate at the speed of the pump that controls the system.

When the pump that controls the system sees that there is too much capacity (operates at the minimum frequency), it makes the started pump to stop. If no auxiliary pumps operate when the pump in control sees overcapacity, the pump goes to the Sleep mode (if the Sleep function is enabled).

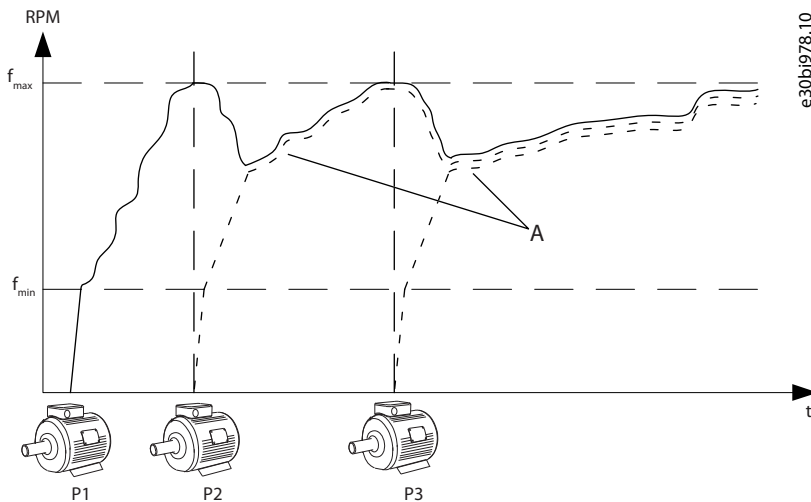

Illustration 91: Control in the Multifollower Mode

P1	The pump controls the system.	P3	The pump follows the speed of P1.
P2	The pump follows the speed of P1.	A	Curve A shows the auxiliary pumps that follow the speed of pump 1.

2 = Multimaster

The Multimaster mode controls a system that has the maximum 8 pumps that can change speed. Each pump is controlled by a drive. The internal PID controller of the drive controls all the pumps.

1 of the pumps always controls the system. When the pump in control sees that it is necessary to have more capacity (operates at the maximum frequency), it locks to a constant production speed and makes the next pump to start and to control the system. When the pump that controls the system sees that there is too much capacity (operates at the minimum frequency), it stops. The pump that operates at a constant production speed starts to control the system. If there are many pumps that operate at a constant production speed, the started pump starts to control the system. If no pumps operate at a constant production speed when the pump in control sees the overcapacity, the pump goes to the Sleep mode (if the Sleep function is enabled).

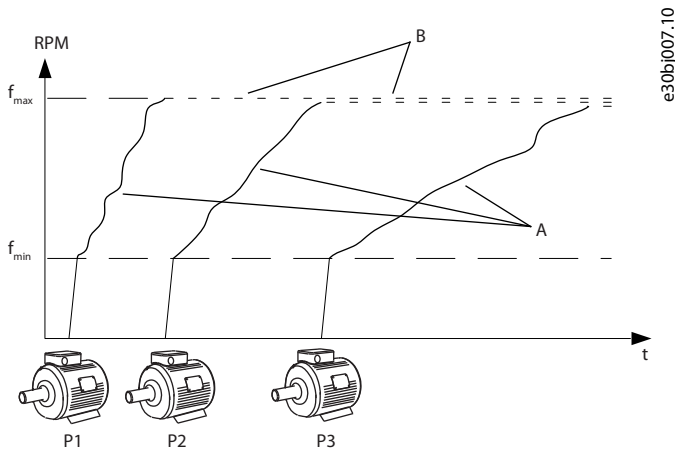

Illustration 92: Control in the Multimaster Mode

- | | |
|---|---|
| A | Curves A show the control of the pumps |
| B | The pumps are locked to the constant production frequency |

11.17.2.4 (ID 1001) Number of Pumps

Location in the menu: **P3.15.2**

Use this parameter to set the total number of motors/pumps used in the Multi-pump system. The maximum number of pumps in the Multi-pump system is 8.

Set this parameter in the installation. If 1 drive is removed to do the servicing of the pump, for example, it is not necessary to change this parameter.

In the Multifollower and Multimaster modes, all drives must have the same value in this parameter for the correct communication between the drives.

11.17.2.5 (ID 1500) Pump ID Number

Location in the menu: **P3.15.3**

Use this parameter to set the ID number of the drive. This parameter is used only in the Multifollower and Multimaster modes.

Each drive in the Multi-pump system must have a unique sequence (ID) number, always start from 1.

Pump number 1 is always the primary master of the Multi-pump system. Drive number 1 controls the process and the PID controller. The PID feedback and the PID setpoint signals must be connected to the drive number 1.

If the drive number 1 is not available in the system, there is a power-down of the drive, for example, the next drive starts to operate as a secondary master of the Multi-pump system.

The communication between the drives is not correct, if:

- the Pump ID numbers are not in a numerical order (start from 1), or
- 2 drives have the same ID number.

11.17.2.6 (ID 1782) Start and Feedback Signals

Location in the menu: **P3.15.4**

Use this parameter to select the signals that are connected to the drive.

0 = The start and the PID feedback signals not connected to the drive in question

1 = Only the start signals connected to the drive in question

2 = The start and the PID feedback signals connected to the drive in question

This parameter specifies the operation mode (master or slave) in the Multi-pump system. The drives that have the start command and the PID feedback signals connected, can operate as the master drive in the Multi-pump system. If there are many drives in the Multi-pump system that have all the signals connected, the drive with the lowest Pump ID Number (P3.15.3) starts to operate as the master.

11.17.3 Interlocks

The interlocks tell the Multi-pump system that a motor is not available. It can occur when the motor is removed from the system for maintenance or bypassed for manual control.

11.17.3.1 (ID 1032) Pump Interlocking

Location in the menu: **P3.15.5**

Use this parameter to enable or disable the interlocks. Interlock signal tells to the Multi-pump system if the motor is available or not. Interlock signals are given with DI signals. To use the interlocks, enable the parameter P3.15.2. Select the status for each motor with a digital input (the parameters from P3.5.1.34 to P3.5.1.39). If the value of the input is CLOSED, that is, active, the Multi-pump logic connects the motor to the Multi-pump system.

11.17.4 Feedback Sensor Connection in a Multi-pump System

To get the best precision and redundancy in the Multi-pump system, use the feedback sensors for each drive.

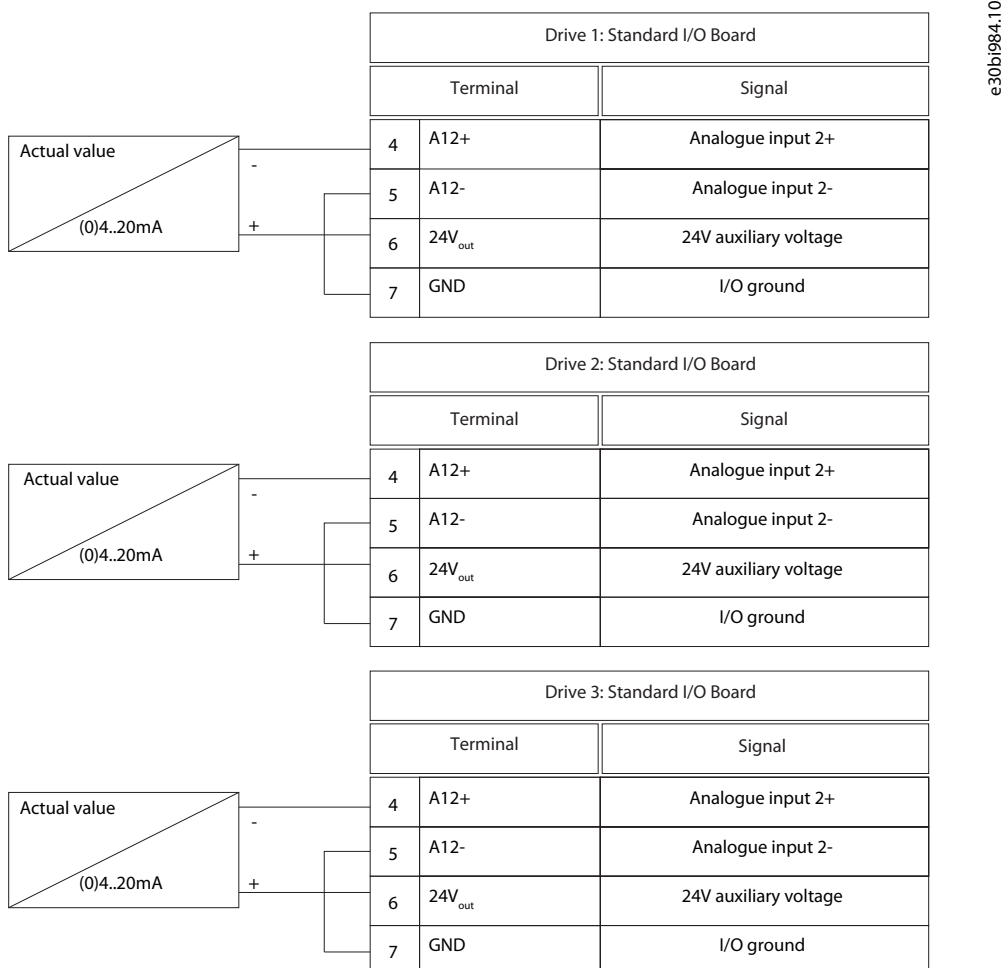

Illustration 93: Wiring of the Feedback Sensors for Each Drive

Same sensors can also be used for all the drives. The sensor (transducer) can be supplied by a 24 V external supply or from the control board the drive.

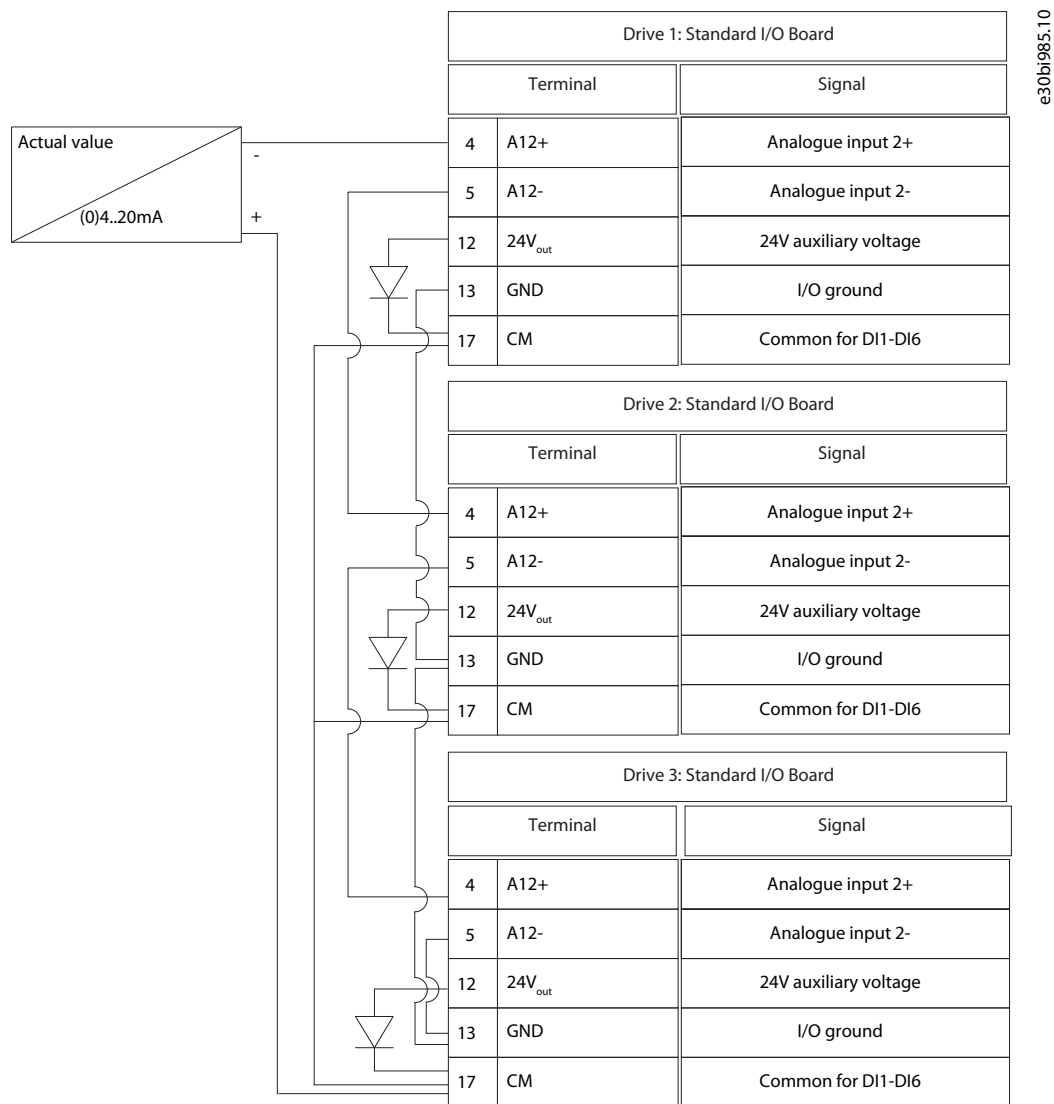

Illustration 94: Wiring of the Same Sensor for All Drives (Supplied from the I/O Board of the Drive)

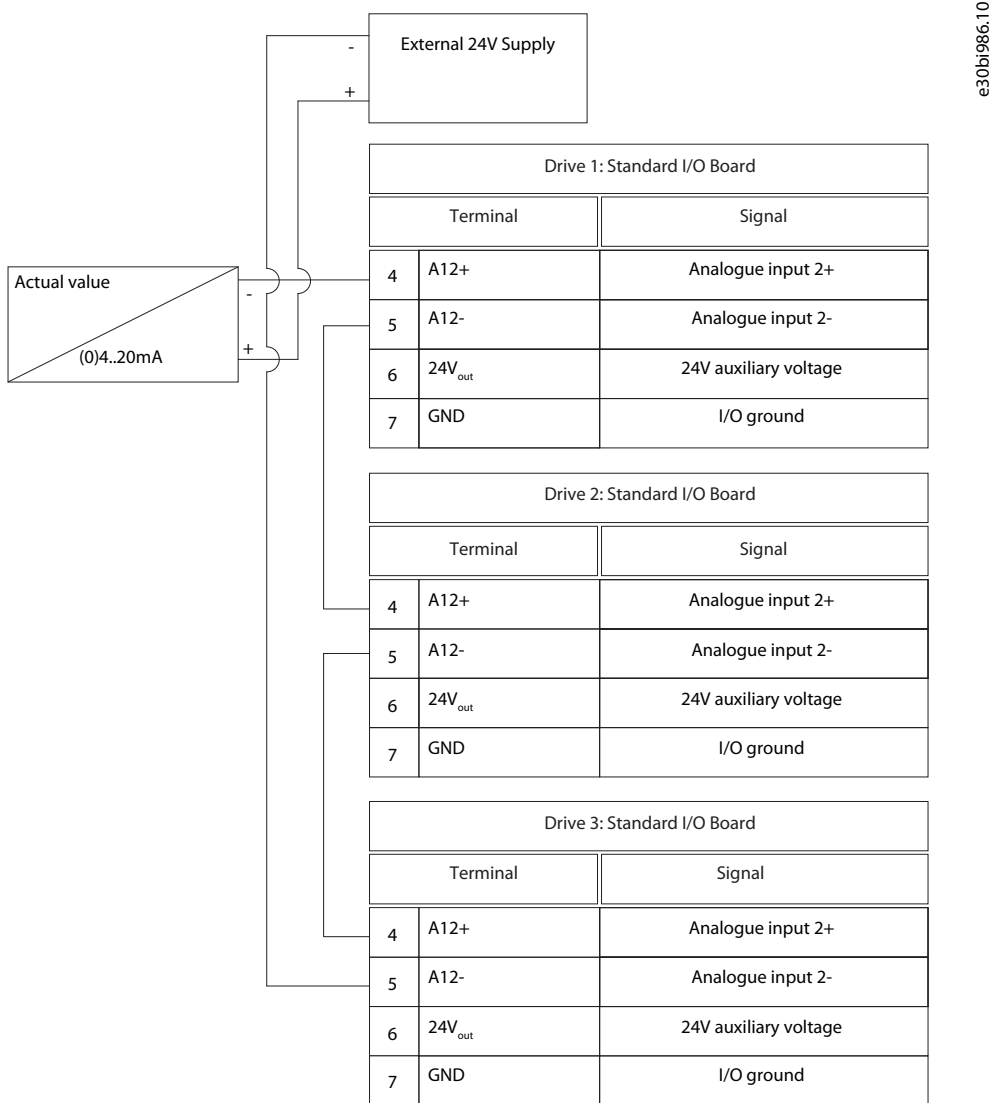

Illustration 95: Wiring of the Same Sensor for All Drives (Supplied from an External 24 V)

If a sensor is supplied from the I/O board of the drive and the diodes are connected between terminals 12 and 17, the digital inputs must be isolated from the ground. Set the isolation DIP switch to *Float*.

The digital inputs are active when they are connected to GND, which is the default condition.

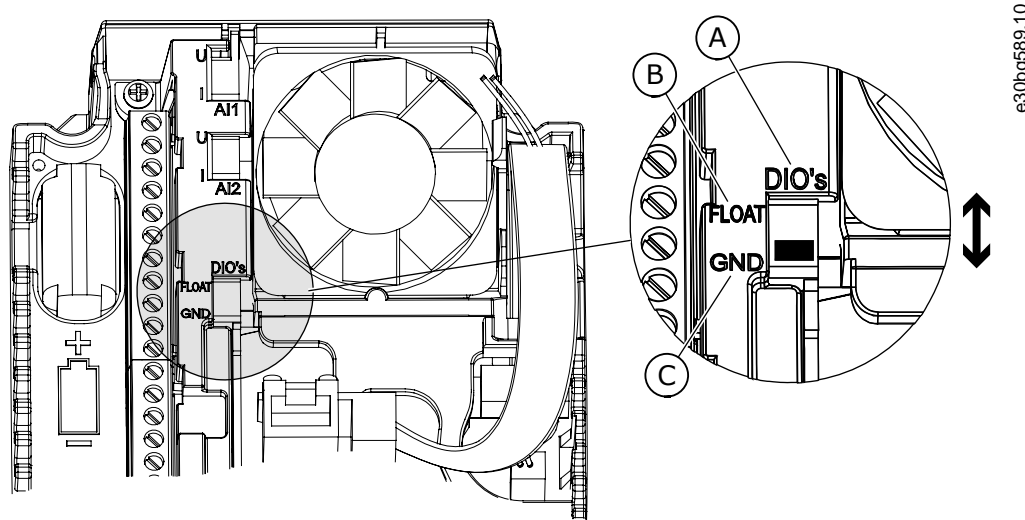

Illustration 96: Isolation DIP Switch

A	Digital inputs	C	Connected to GND (default)
B	Float		

11.17.4.1 (ID 1027) Autochange

Location in the menu: **P3.15.6**

Use this parameter to enable or disable the rotation of the start sequence and the priority of motors. The autochange changes the sequence in which the motors start to wear the motors equally.

The monitoring values V2.10.7 Pump 1 Running Time – V2.10.14 Pump 8 Running Time count the run-time of the motors. The autochange function sets the start sequence according to the run-times. The motor that has the lowest running hours starts first and the motor that has the highest running hours starts last.

Selection number	Selection name	Description
0	Disabled	In normal operation, the sequence of the motors is always 1, 2, 3, 4, 5. The sequence can change during the operation if interlocks are added or removed. After the drive stops, the sequence always changes back.
1	Enabled (interval)	The system changes the sequence at intervals to wear the motors equally. The intervals of the autochange can be adjusted with parameter P3.15.8. The timer of the autochange interval operates only when the Multi-pump system operates.
2	Enabled (week-days)	The start sequence changes at the selected weekday and time of day. Make the selection with parameters P3.15.9 and P3.15.10. To use this mode, an RTC battery must be installed in the drive.

Example

After an autochange, the first motor is put last. The other motors move up 1 position.

The start sequence of the motors: 1, 2, 3, 4, 5

--> Autochange -->

The start sequence of the motors: 2, 3, 4, 5, 1

--> Autochange -->

The start sequence of the motors: 3, 4, 5, 1, 2

11.17.4.2 (ID 1028) Autochanged Pumps

Location in the menu: **P3.15.7**

Use this parameter to include the controlled motor/pump in the autochange and interlock system.

Selection number	Selection name	Description
0	Auxiliary pumps	The drive is always connected to Motor 1. The interlocks do not affect Motor 1. Motor 1 is not included in the autochange logic.
1	All pumps	It is possible to connect the drive to any of the motors in the system. The interlocks affect all the motors. All the motors are included in the autochange logic.

The connections are different for the parameter values 0 and 1.

Selection 0, Auxiliary pumps

The drive is directly connected to Motor 1. The other motors are auxiliary motors. They are connected to the mains by contactors, and controlled by relays of the drive. The autochange or the interlock logic does not affect Motor 1.

Selection 1, All pumps

To include the regulating motor in the autochange or in the interlock logic, obey the instructions in the following figure. 1 relay controls each motor. The contactor logic always connects the first motor to the drive, and the next motors to the mains.

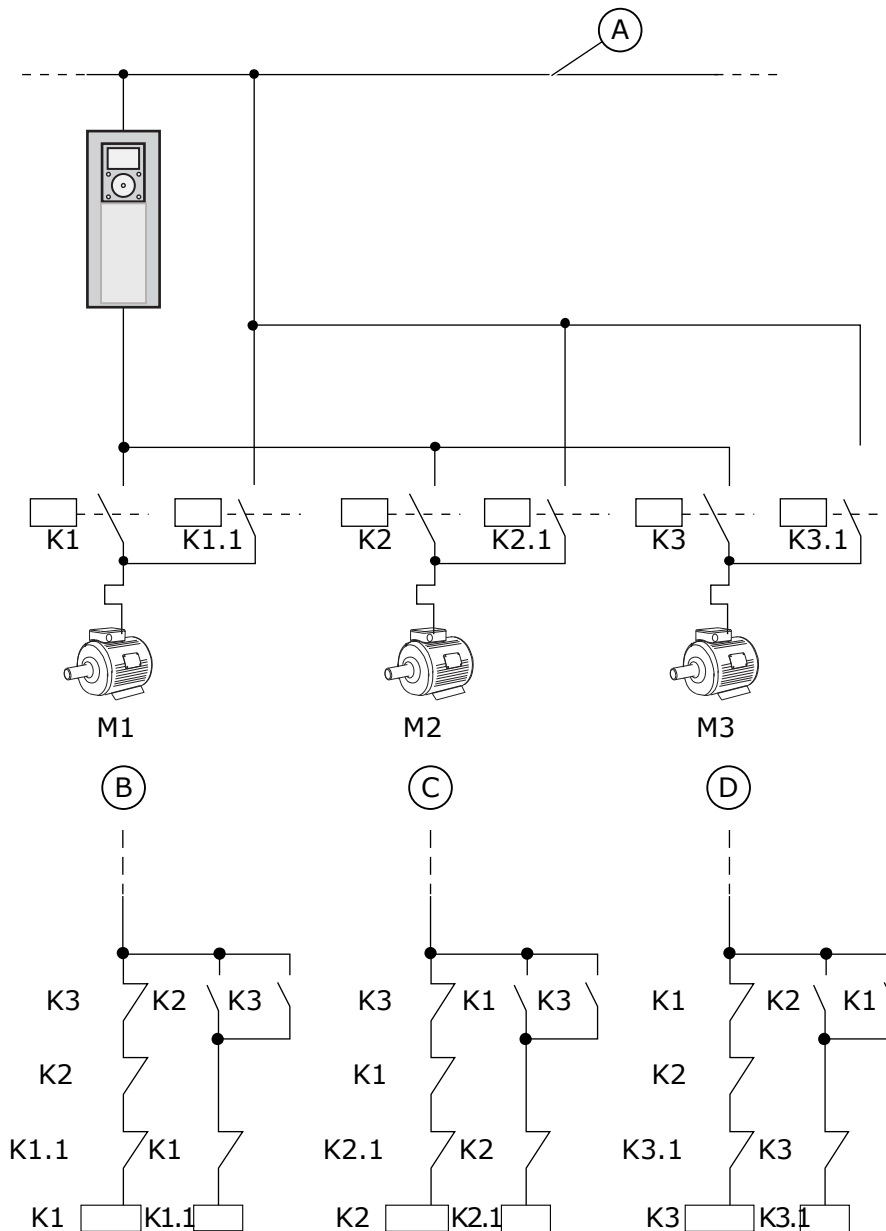

e30bg320.10

Illustration 97: Selection 1

A	Mains	C	Motor 2 control from relay
B	Motor 1 control from relay	D	Motor 3 control from relay

11.17.4.3 (ID 1029) Autochange Interval

Location in the menu: **P3.15.8**

Use this parameter to adjust the autochange intervals. The Autochange interval is the time after which the autochange function starts if the used capacity is below the set level. The value of this timer does not run when the Multi-pump system is stopped or in the sleep mode. To use the parameter, select Enabled (interval) with parameter P3.15.6 Autochange Mode.

The autochange occurs, if:

- the Multi-pump system operates (the start command is active)
- the autochange interval time goes
- the pump that controls the system operates below the frequency specified by parameter P3.15.11 Autochange Frequency Limit
- the number of pumps that operate is less or equal to the limit specified by parameter P3.15.12 Autochange Pump Limit.

11.17.4.4 (ID 1786) Autochange Days

Location in the menu: **P3.15.9**

Use this parameter to set the days of the week when the autochange function starts. The value of this parameter is applied if the autochange mode is 'Enabled (Weekdays)'.

11.17.4.5 (ID 1787) Autochange Time of Day

Location in the menu: **P3.15.10**

Use this parameter to set the time of the day when the autochange function starts. The value of this parameter is applied if the autochange mode is Enabled (Weekdays). To use the parameters, select Enabled (Weekdays) with parameter P3.15.6 Autochange.

The autochange occurs, if:

- the Multi-pump system operates (the start command is active)
- it is the autochange weekday and the time of day
- the pump that controls the system operates below the frequency specified by parameter P3.15.11 Autochange Frequency Limit
- the number of pumps that operate is less or equal to the limit specified by parameter P3.15.12 Autochange Pump Limit.

11.17.4.6 (ID 1031) Autochange Frequency Limit

Location in the menu: **P3.15.11**

Use this parameter to set the autochange frequency limit. The autochange frequency limit is the limit below which the output frequency of the regulating drive must stay for the autochange to start.

11.17.4.7 (ID 1030) Autochange Pump Limit

Location in the menu: **P3.15.12**

Use this parameter to set the amount of pumps used in the Multi-pump function. The Autochange Pump Limit is the limit below which the number of the running motors must stay for the autochange to start.

If the number of pumps that operate in the Multi-pump system is less or equal to the limit specified by parameter P3.15.12 and the pump that controls the system operates below the frequency specified by parameter P3.15.11, the autochange can occur.

These parameters are used in the Single drive mode, because the autochange can restart the system (depending on the quantity of motors that operate).

In the Multifollower and Multimaster modes, set these parameters to the maximum values to make it possible for the autochange to occur immediately at the autochange time. In the Multifollower and Multimaster modes, the quantity of pumps that operate does not affect the autochange.

11.17.4.8 (ID 1097) Bandwidth

Location in the menu: **P3.15.13**

Use this parameter to set the bandwidth area around the PID setpoint for starting and stopping of the auxiliary motors. When the PID feedback value stays in the bandwidth area, the auxiliary motors do not start or stop. The value of this parameter is given as a percentage of the setpoint.

11.17.4.9 (ID 1098) Bandwidth Delay

Location in the menu: **P3.15.14**

Use this parameter to set the duration before the auxiliary motors start or stop. When the PID feedback is not in the bandwidth area, the time that is set with this parameter must go before the auxiliary motors start or stop. The number of pumps that operate increases or decreases, if the PID controller cannot keep the process value (feedback) in the specified bandwidth around the setpoint.

The bandwidth area is specified as a percentage of the PID setpoint. When the PID feedback value stays in the bandwidth area, it is not necessary to increase or decrease the number of pumps that operate.

When the feedback value goes out of the bandwidth area, the quantity of time specified by parameter P3.15.14 must go before the number of pumps that operate increases or decreases. More pumps must be available.

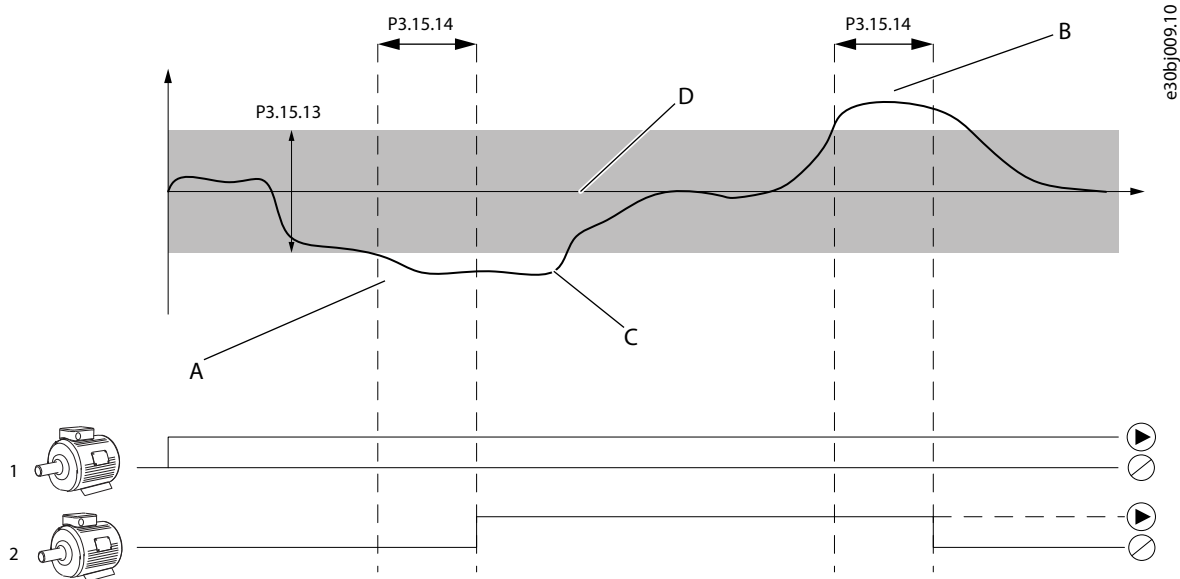

Illustration 98: The Start or Stop of the Auxiliary Pumps (P3.15.13 = Bandwidth, P3.15.14 = Bandwidth delay)

<p>A The pump that controls the system operates at a frequency that is near the maximum (-2 Hz). It increases the number of pumps that operate.</p>	<p>C The number pumps that operate increases or decreases, if the PID controller cannot keep the process value feedback in the specified bandwidth around the setpoint.</p>
<p>B The pump that controls the system operates at a frequency that is near the minimum (+2 Hz). It decreases the number of pumps that operate.</p>	<p>D The specified bandwidth around the setpoint.</p>

11.17.4.10 (ID 1513) Constant Production Speed

Location in the menu: **P3.15.15**

Use this parameter to set the constant speed at which the motor locks when the next motor starts in the Multimaster system. The value of this parameter is given as a percentage of the minimum frequency to the maximum frequency.

11.17.4.11 (ID 1187) Running Pumps Limit

Location in the menu: **P3.15.16**

Use this parameter to set the maximum number of motors that run at the same time in the Multi-pump system.

If the value of parameter P3.15.2 Number of Pumps changes, the same value changes automatically to this parameter.

Example

The Multi-pump system has 3 pumps, but only 2 pumps can operate at the same time. The third pump is installed in the system for redundancy. The number of pumps that can operate at the same time:

- Running Pump Limit = 2

11.17.4.12 (ID 426) Pump 1 Interlock

Location in the menu: **P3.15.17.1**

Use this parameter to select the digital input signal that is used as interlock signal for the multi-pump system.

When the Pump interlocking function (P3.15.5) is enabled, the drive reads the statuses of the digital inputs of the pump interlock (feedback). When the input is CLOSED, the motor is available for the Multi-pump system.

When the Pump interlocking function (P3.15.5) is disabled, the drive does not read the statuses of the digital inputs of the pump interlock (feedback). The Multi-pump system sees all pumps in the system as available.

- In the Single drive mode, the digital input signal that is selected with this parameter shows the interlock status of pump 1 in the Multi-pump system.
- In the Multifollower and Multimaster modes, the digital input signal that is selected with this parameter shows the interlock status of the pump that is connected to this drive.

11.17.4.13 (ID 427) Pump 2 Interlock

Location in the menu: **P3.15.17.2**

Use this parameter to select the digital input signal that is used as interlock signal for the multi-pump system.

11.17.4.14 (ID 428) Pump 3 Interlock

Location in the menu: **P3.15.17.3**

Use this parameter to select the digital input signal that is used as interlock signal for the multi-pump system.

11.17.4.15 (ID 429) Pump 4 Interlock

Location in the menu: **P3.15.17.4**

Use this parameter to select the digital input signal that is used as interlock signal for the multi-pump system.

11.17.4.16 (ID 430) Pump 5 Interlock

Location in the menu: **P3.15.17.5**

Use this parameter to select the digital input signal that is used as interlock signal for the multi-pump system.

11.17.4.17 (ID 486) Pump 6 Interlock

Location in the menu: **P3.15.17.6**

Use this parameter to select the digital input signal that is used as interlock signal for the multi-pump system.

11.17.4.18 (ID 487) Pump 7 Interlock

Location in the menu: **P3.15.17.7**

Use this parameter to select the digital input signal that is used as interlock signal for the multi-pump system.

11.17.4.19 (ID 488) Pump 8 Interlock

Location in the menu: **P3.15.17.8**

Use this parameter to select the digital input signal that is used as interlock signal for the multi-pump system.

These parameters are used in the Single drive mode only.

When the Pump interlocking function (P3.15.5) is enabled, the drive reads the statuses of the digital inputs of the pump interlock (feedback). When the input is CLOSED, the motor is available for the Multi-pump system.

When the Pump interlocking function (P3.15.5) is disabled, the drive does not read the statuses of the digital inputs of the pump interlock (feedback). The Multi-pump system sees all pumps in the system as available.

11.17.5 Overpressure Supervision

Use the Overpressure supervision function in a Multi-pump system. For example, when the primary valve of the pump system is closed quickly, the pressure in the pipe lines increases. The pressure can increase too quickly for the PID controller. To prevent that the pipes break, the overpressure supervision stops the auxiliary motors in the Multi-pump system.

11.17.5.1 (ID 1698) Enable Overpressure Supervision

Location in the menu: **P3.15.18.1**

Use this parameter to enable the Overpressure supervision.

The overpressure supervision monitors the feedback signal of the PID controller, that is, the pressure. If the signal becomes higher than the overpressure level, it stops all the auxiliary pumps immediately. Only the regulating motor continues to operate. When the pressure decreases, the system continues to operate, and connects the auxiliary motors again one at a time.

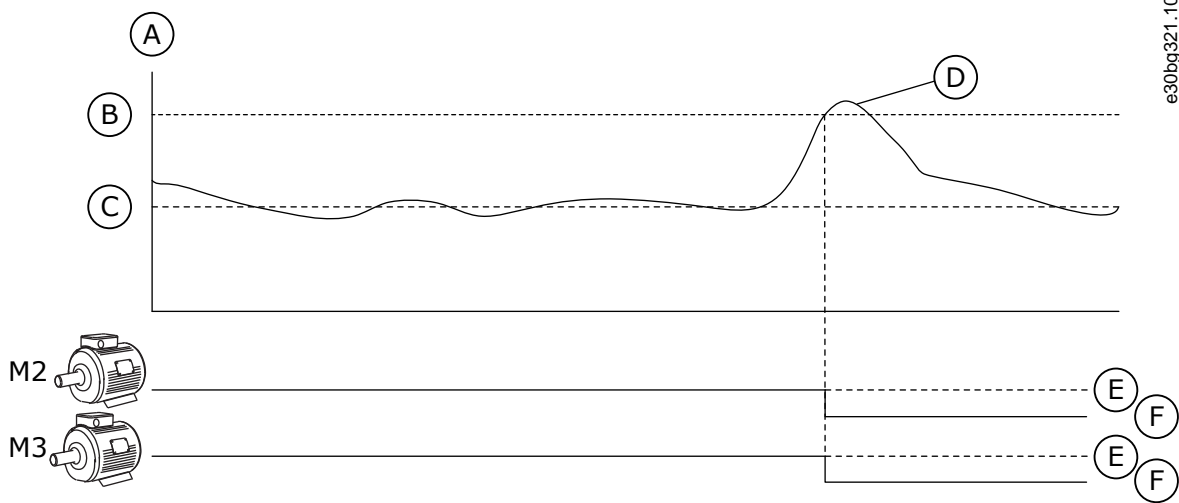

e30bg321.10

Illustration 99: The Overpressure Supervision Function

A	Pressure	D	PID Feedback (ID21)
B	Supervision Alarm Level (ID1699)	E	ON
C	PID Setpoint (ID167)	F	OFF

11.17.5.2 (ID 1699) Supervision Alarm Level

Location in the menu: **P3.15.16.2**

Use this parameter to set the overpressure limit for the Overpressure supervision. If the PID feedback becomes higher than the set overpressure limit, all auxiliary motors stop immediately. Only the regulating motor continues to operate.

11.17.6 Pump Run-time Counters

In the Multi-pump system, the time that each pump operates is monitored by a run-time counter. For example, the order that the pumps start is specified by the run-time counter values to make the wear of the pumps in the system more equal. The pump run-time counters also tell the operator to do maintenance on a pump (parameters P3.15.19.4 - P3.15.19.5).

The Pump run-time counters are in the monitoring menu, see [Table 21](#).

11.17.6.1 (ID 1673) Set Run-time Counter

Location in the menu: **P3.15.19.1**

Use this parameter to set the value that is specified by 'Set Run-time: Value' parameter to the run-time counter of the selected pump.

11.17.6.2 (ID 1087) Set Run-time Counter: Value

Location in the menu: **P3.15.19.2**

Use this parameter to set the value of the run-time counter of the selected pump when 'Set Run-time Counter' parameter is selected.

In the Multimaster and Multifollower modes, it is possible to reset or set the necessary value only to the counter Pump (1) Running Time. In the Multimaster and Multifollower modes, the monitoring value Pump (1) Running Time shows the hours of the pump that is connected to this drive. The ID number of the pump has no effect.

Example

In the Multi-pump (single drive) system, pump number 4 is replaced with a new pump. The counter value of Pump 4 Running Time must be reset.

1. Select *Pump 4* with parameter P3.15.19.3.
2. Set parameter P3.15.19.2 value to 0 h.
3. Push the button-type parameter P3.15.19.1.
4. Pump 4 Running Time is reset.

11.17.6.3 (ID 1088) Set Run-time Counter: Pump Selection

Location in the menu: **P3.15.19.3**

Use this parameter to select the pumps for which the run-time counter value is specified by 'Set Run-time: Value' parameter.

If the Multi-pump (single drive) mode is selected, the next selections are available:

- 0 = All Pumps
- 1 = Pump (1)
- 2 = Pump 2
- 3 = Pump 3
- 4 = Pump 4
- 5 = Pump 5
- 6 = Pump 6
- 7 = Pump 7
- 8 = Pump 8

If the Multifollower or Multimaster mode is selected, only the next selection is available:

- 1 = Pump (1)

In the Multimaster and Multifollower modes, it is possible to reset or to set a necessary value only for the Pump (1) Running Time. In the Multimaster and Multifollower modes, the monitoring value Pump (1) Running Time shows the hours of the pump that is connected to this drive. The ID number of the pump has no effect.

Example

In the Multi-pump (single drive) system, pump number 4 is replaced with a new pump. The counter value of Pump 4 Running Time must be reset.

1. Select *Pump 4* with parameter P3.15.19.3.
2. Set parameter P3.15.19.2 value to 0 h.
3. Push the button-type parameter P3.15.19.1.
4. Pump 4 Running Time is reset.

11.17.6.4 (ID 1109) Pump Run-time Alarm Limit

Location in the menu: **P3.15.19.4**

Use this parameter to set the alarm limit for the run-time counter of the pump. When the value of the pump run-time counter goes above this limit, a run-time counter alarm occurs.

11.17.6.5 (ID 1110) Pump Run-time Fault Limit

Location in the menu: **P3.15.19.5**

Use this parameter to set the fault limit for the run-time counter of the pump. When the value of the pump run-time counter goes above this limit, a run-time counter fault occurs.

11.17.7 Advanced Settings

11.17.7.1 (ID 15545) Staging Frequency

Location in the menu: **P3.15.22.1**

Use this parameter to adjust the output frequency level at which the auxiliary motor starts in the Multi-pump system.

The parameter has no effect, if its value is set above Max Frequency Reference (P3.3.1.2).

By default, an auxiliary pump starts (is staged), if the PID feedback signal goes below the specified bandwidth area and the pump that controls the system operates at the maximum frequency.

The auxiliary pump can start at a lower frequency to get better process values or to use less energy. Then, use the parameter to set the start frequency of the auxiliary pump below the maximum frequency.

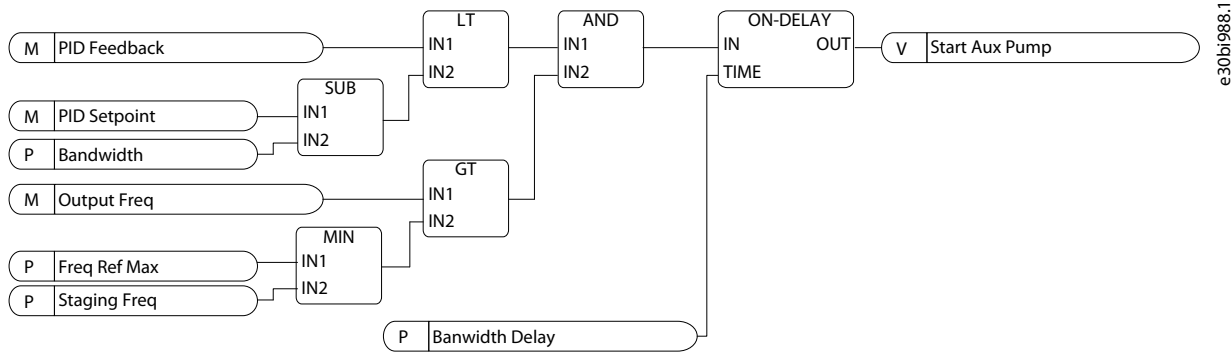

Illustration 100: Staging Frequency

11.17.7.2 (ID 15546) Destaging Frequency

Location in the menu: **P3.15.22.2**

Use this parameter to adjust the output frequency level at which the auxiliary motor starts in the Multi-pump system.

The parameter has no effect, if its value is set below Min Frequency Reference (P3.3.1.1).

By default, an auxiliary pump stops (is destaged), if the PID feedback signal goes above the specified bandwidth area and the pump that controls the system operates at the minimum frequency.

The auxiliary pump can stop at a higher frequency to get better process values or to use less energy. Then, use the parameter to set the start frequency of the auxiliary pump above the minimum frequency.

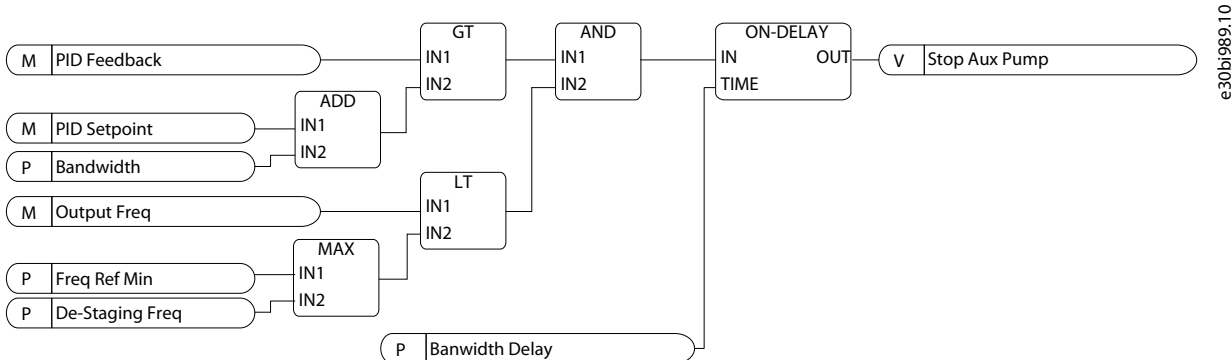

Illustration 101: Destaging Frequency

11.17.7.3 (ID 15588) Staging Delay

Location in the menu: **P3.15.22.3**

Use this parameter to give a delay to start the next auxiliary pump in the Multi-pump system.

When PID feedback value goes below the bandwidth area, the time defined by this parameter must elapse before the next auxiliary pump is started.

11.17.7.4 (ID 15589) Destaging Delay

Location in the menu: **P3.15.22.4**

Use this parameter to give a delay to stop auxiliary pump in the Multi-pump system.

When PID feedback value goes above the bandwidth area, the time defined by this parameter must elapse before the next auxiliary pump is stopped.

11.18 Maintenance Counters

11.18.1 The Maintenance Counters

A maintenance counter tells that maintenance must be done. For example, it is necessary to replace a belt or to replace the oil in a gearbox. There are 2 different modes for the maintenance counters, hours, or revolutions*1000. The value of the counters increases only during the RUN status of the drive.

⚠ CAUTION ⚠

MAINTENANCE HAZARD

Only an approved electrician can do maintenance. There is a risk of injury.

- Do not do maintenance if you are not approved to do it.

N O T I C E

The revolutions mode uses motor speed, which is only an estimate. The drive measures the speed every second.

When the value of a counter is more than its limit, an alarm, or a fault shows. It is possible to connect the alarm and fault signals to a digital output or a relay output.

When the maintenance is completed, reset the counter with a digital input or parameter P3.16.4 Counter 1 Reset.

11.18.2 (ID 1104) Counter 1 Mode

Location in the menu: **P3.16.1**

Use this parameter to enable the maintenance counter. A maintenance counter tells that the maintenance must be done when the counter value goes above the set limit.

11.18.3 (ID 1105) Counter 1 Alarm Limit

Location in the menu: **P3.16.2**

Use this parameter to set the alarm limit for the maintenance counter. When the value of the counter goes above this limit, a maintenance alarm occurs.

11.18.4 (ID 1106) Counter 1 Fault Limit

Location in the menu: **P3.16.3**

Use this parameter to set the fault limit for the maintenance counter. When the value of the counter goes above this limit, a maintenance fault occurs.

11.18.5 (ID 1107) Counter 1 Reset

Location in the menu: **P3.16.4**

Use this parameter to reset the maintenance counter.

11.18.6 (ID 490) Counter 1 DI Reset

Location in the menu: **P3.16.5**

Use this parameter to select the digital input that resets the value of the Maintenance Counter.

11.19 Fire Mode

11.19.1 The Fire Mode Function

When Fire mode is active, the drive resets all faults that occur and continues to operate at the same speed until it is not possible. The drive ignores all commands from the keypad, fieldbuses, and the PC tool. It only obeys the signals Fire Mode Activation, Fire Mode Reverse, Run Enable, Run Interlock 1, and Run Interlock 2 from I/O.

The Fire mode function has 2 modes, the Test mode, and the Enabled mode. To select a mode, write a password in parameter P3.17.1 (Fire Mode Password). In the Test mode, the drive does not automatically reset the faults, and the drive stops when a fault occurs.

It is also possible to configure Fire mode with the Fire mode wizard, which can be activated in the Quick Setup menu with parameter B1.1.4.

When the Fire mode function is activated, an alarm shows on the display.

N O T I C E

WARRANTY BECOMING VOID

The warranty is void if the Fire mode function is activated.

- Use Test mode to test the Fire mode function and the warranty stays valid.

11.19.2 (ID 1599) Fire Mode Password

Location in the menu: **P3.17.1**

Use this parameter to enable the fire mode function.

N O T I C E

All other fire mode parameters are locked when the fire mode is enabled and correct password is set in this parameter.

Selection number	Selection name	Description
1002	Enabled mode	The drive resets all the faults and continues to operate at the same speed until it is not possible.
1234	Test mode	The drive does not automatically reset the faults, and the drive stops when a fault occurs.

11.19.3 (ID 1617) Fire Mode Frequency Source

Location in the menu: **P3.17.2**

Use this parameter to select the frequency reference source when the fire mode is active. This parameter enables the selection of, for example, the AI1, or the PID controller as the reference source when operating the fire mode.

11.19.4 (ID 1598) Fire Mode Frequency

Location in the menu: **P3.17.3**

Use this parameter to set the frequency that is used when Fire mode is active. The drive uses this frequency when the value of parameter P3.17.2 Fire Mode Frequency Source is Fire Mode Frequency.

11.19.5 (ID 1596) Fire Mode Activation on Open

Location in the menu: **P3.17.4**

Use this parameter to select the digital input signal that activates the Fire Mode function. If this digital input signal is activated, an alarm shows on the display, and the warranty becomes void. The type of this digital input signal is NC (normally closed).

It is possible to try the Fire mode with the password that activates the Test mode. Then the warranty stays valid.

N O T I C E

If Fire mode is enabled, and the correct password is given to the parameter Fire Mode Password, all the Fire mode parameters become locked. To change the Fire mode parameters, change the value of P3.17.1 Fire Mode Password to 0 first.

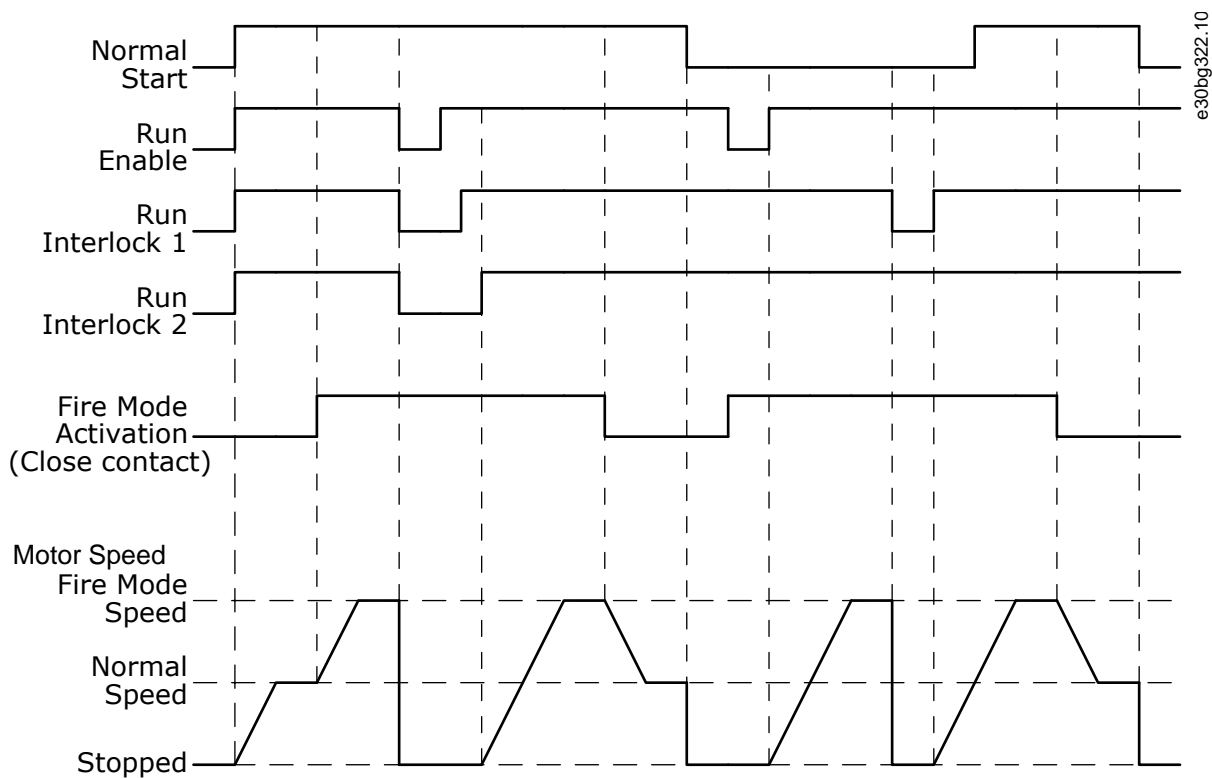

Illustration 102: The Fire Mode Function

11.19.6 (ID 1619) Fire Mode Activation on Close

Location in the menu: **P3.17.5**

Use this parameter to select the digital input signal that activates the Fire Mode function. The type of this digital input signal is NO (normally open). See the description for P3.17.4 Fire Mode Activation on Open.

11.19.7 (ID 1618) Fire Mode Reverse

Location in the menu: **P3.17.6**

Use this parameter to select the digital input signal that gives a command for reverse rotation direction during the Fire Mode. The parameter does not affect normal operation.

If it is necessary for the motor to operate always FORWARD or always REVERSE in Fire Mode, select the correct digital input.

DigIn Slot0.1 = always FORWARD

DigIn Slot0.2 = always REVERSE

11.19.8 (ID 1597) Fire Mode Status

Location in the menu: **V3.17.7**

This monitoring value shows the status of the fire mode function.

11.19.9 (ID 1679) Fire Mode Counter

Location in the menu: **V3.17.8**

This monitoring value shows the number of the fire mode activations.

The counter cannot be reset.

11.19.10 (ID 15580) Fire Mode Run Indication Current

Location in the menu: **P3.17.9**

Use this parameter to set the current limit for the run indication signal of the relay output.

This parameter only affects if the value "Run indication" is selected for a relay output and the fire mode is active. The "Run indication" relay output function tells quickly if current is supplied to the motor during a fire.

The value of this parameter is the percentage counted from the motor nominal current. If there is a fire and the current that is supplied to the motor is more than the nominal current times the value of this parameter, the relay output closes.

For example, if parameter Motor Nominal Current has the value 5 A, and 20% is set as the default value of this parameter, the relay output closes and Fire Mode activates when the output current goes to 1 A.

This parameter does not affect if the fire mode is not active. In normal operation, if "Run indication" is selected for a relay output, the result is the same as when "Run" is selected for the relay output.

11.20 Motor Preheat Function

11.20.1 (ID 1225) Motor Preheat Function

Location in the menu: **P3.18.1**

Use this parameter to enable or disable the Motor Preheat function. The motor preheat function keeps the drive and the motor warm during the STOP status. In the motor preheat, the system gives the motor a DC current. The motor preheat prevents, for example, condensation.

Selection number	Selection name	Description
0	Not used	The motor preheat function is disabled.
1	Always in Stop state	The motor preheat function is activated always when the drive is in the Stop state.
2	Controlled by digital input	The motor preheat function is activated by a digital input signal, when the drive is in the Stop state. It is possible to make the selection of the digital input for the activation with parameter P3.5.1.18.
3	Temperature limit (heat sink)	The motor preheat function is activated if the drive is in the Stop state, and the temperature of the heat sink of the drive goes below the temperature limit that was set with parameter P3.18.2.
4	Temperature limit (measured motor temperature)	The motor preheat function is activated if the drive is in the Stop state, and the measured motor temperature goes below the temperature limit that was set with parameter P3.18.2. It is possible to set the measurement signal of the motor temperature with parameter P3.18.5. NOTE! To use this operation mode, an option board for temperature measurement (for example OPTBH) is needed.

11.20.2 (ID 1226) Preheat Temperature Limit

Location in the menu: **P3.18.2**

Use this parameter to set the temperature limit of the Motor Preheat function. The motor preheat becomes active when the heat sink temperature or the measured motor temperature goes below this level, and when P3.18.1 is set to 3 or 4.

11.20.3 (ID 1227) Motor Preheat Current

Location in the menu: **P3.18.3**

Use this parameter to set the DC current of the Motor Preheat function. The DC current for the pre-heating of the motor and the drive in stop state. Activated as in P3.18.1.

11.20.4 (ID 1044) Motor Preheat ON

Location in the menu: **P3.18.4**

Use this parameter to select the digital input signal that activates Motor Preheat function. This parameter is used when P3.18.1 is set to 2. When the value for P3.18.1 is 2, it is also possible to connect time channels to this parameter.

11.20.5 (ID 1045) Preheat Motor Temperature

Location in the menu: **P3.18.5**

Use this parameter to select the temperature signal that is used to measure the motor temperature for motor preheat function.

N O T I C E

This parameter is not available if there is no option board for temperature measurement.

11.21 Drive Customizer

11.21.1 (ID 15001) Operation Mode

Location in the menu: **P3.19.1**

Use this parameter to select the operation mode of the drive customizer.

Selection number	Selection name	Description
0	Execute Program	The Drive customizer is running. Configuration is not allowed for the Drive customizer.
1	Programming	The Drive customizer is not running. Configuration is allowed for the Drive customizer.

11.22 Pump Control

11.22.1 Auto-Cleaning

Use the Auto-cleaning function to remove dirt or other material from the pump impeller. It is also possible to use the function to clear a blocked pipe or valve. It is possible to use the auto-cleaning, for example, in wastewater systems to keep the performance of the pump satisfactory.

11.22.1.1 (ID 1714) Cleaning Function

Location in the menu: **P3.21.1.1**

Use this parameter to enable the Auto-cleaning function.

Selection number	Selection name	Description
0	Disabled	
1	Enabled (DIN)	The cleaning sequence is started with a digital input signal. If the start command of the drive is active, a rising edge of the digital input signal (P3.21.1.2) starts the cleaning sequence. If the drive is in the Sleep mode (PID sleep), the cleaning sequence can also be activated.
2	Enabled (Current)	The cleaning sequence starts when the motor current goes above the current limit (P3.21.1.3) for a longer time than specified by P3.21.1.4.
3	Enabled (Real Time)	The cleaning sequence agrees with the internal real-time clock of the drive.

N O T I C E

A battery must be installed in the real-time clock.

If the start command of the drive is active, the cleaning sequence starts on the selected weekdays (P3.21.1.5) at the specified time of the day (P3.21.1.6). If the drive is in the Sleep mode (PID sleep), the cleaning sequence can also be activated.

To stop the cleaning sequence, deactivate the start command of the drive. When 0 is selected, the cleaning function is not used.

11.22.1.2 (ID 1715) Cleaning Activation

Location in the menu: **P3.21.1.2**

Use this parameter to select the digital input signal that starts the Auto-cleaning sequence. The auto-cleaning stops if the activation signal is removed before the sequence is complete.

N O T I C E

If the input is activated, the drive starts.

11.22.1.3 (ID 1712) Cleaning Current Limit

Location in the menu: **P3.21.1.3**

Use this parameter to set the current limit at which the Auto-cleaning starts. If the current of the motor stays above this limit for longer than the set time, an autocleaning sequence starts.

11.22.1.4 (ID 1713) Cleaning Current Delay

Location in the menu: **P3.21.1.4**

Use this parameter to set the time that the motor current must stay above the limit before the auto-cleaning starts.

Parameters P3.21.1.3 and P3.21.1.4 are used only when P3.21.1.1 = 2.

The cleaning sequence starts when the motor current goes above the current limit (P3.21.1.3) for longer than specified with P3.21.1.4. The current limit is specified as a percentage of the motor nominal current.

11.22.1.5 (ID 1715) Cleaning Weekdays

Location in the menu: **P3.21.1.5**

Use this parameter to set the days of the week when the Auto-cleaning is executed. This parameter is used only when P3.21.1.1 = 3.

11.22.1.6 (ID 1700) Cleaning Time of Day

Location in the menu: **P3.21.1.6**

Use this parameter to set the time of the day when the Auto-cleaning is executed. This parameter is used only when P3.21.1.1 = 3.

NOTICE

A battery must be installed in the real-time clock.

11.22.1.7 (ID 1716) Cleaning Cycles

Location in the menu: **P3.21.1.7**

Use this parameter to set the number of forward or reverse cleaning cycles.

11.22.1.8 (ID 1717) Clean Forward Frequency

Location in the menu: **P3.21.1.8**

Use this parameter to set the frequency reference of the drive for the forward direction in the Auto-cleaning cycle.

Set the frequency and time of the cleaning cycle with the parameters P3.21.1.4, P3.21.1.5, P3.21.1.6, and P3.21.1.7.

11.22.1.9 (ID 1718) Clean Forward Time

Location in the menu: **P3.21.1.9**

Use this parameter to set the operation time for the forward direction frequency in the Autocleaning cycle. See parameter [11.22.1.8 \(ID 1717\) Clean Forward Frequency](#).

11.22.1.10 (ID 1719) Clean Reverse Frequency

Location in the menu: **P3.21.1.10**

Use this parameter to set the frequency reference of the drive for the reverse direction in the Auto-cleaning cycle. See parameter [11.22.1.8 \(ID 1717\) Clean Forward Frequency](#).

11.22.1.11 (ID 1720) Clean Reverse Time

Location in the menu: **P3.21.1.11**

Use this parameter to set the operation time for the reverse direction frequency in the Autocleaning cycle. See parameter [11.22.1.8 \(ID 1717\) Clean Forward Frequency](#).

11.22.1.12 (ID 1721) Cleaning Acceleration Time

Location in the menu: **P3.21.1.12**

Use this parameter to set the motor acceleration time when the Auto-cleaning is active. It is possible to set acceleration and deceleration ramps for the Auto-cleaning function with parameters P3.21.1.12 and P3.21.1.13.

11.22.1.13 (ID 1722) Cleaning Deceleration Time

Location in the menu: **P3.21.1.13**

Use this parameter to set the motor deceleration time when the Auto-cleaning is active. It is possible to set acceleration and deceleration ramps for the Auto-cleaning function with parameters P3.21.1.12 and P3.21.1.13.

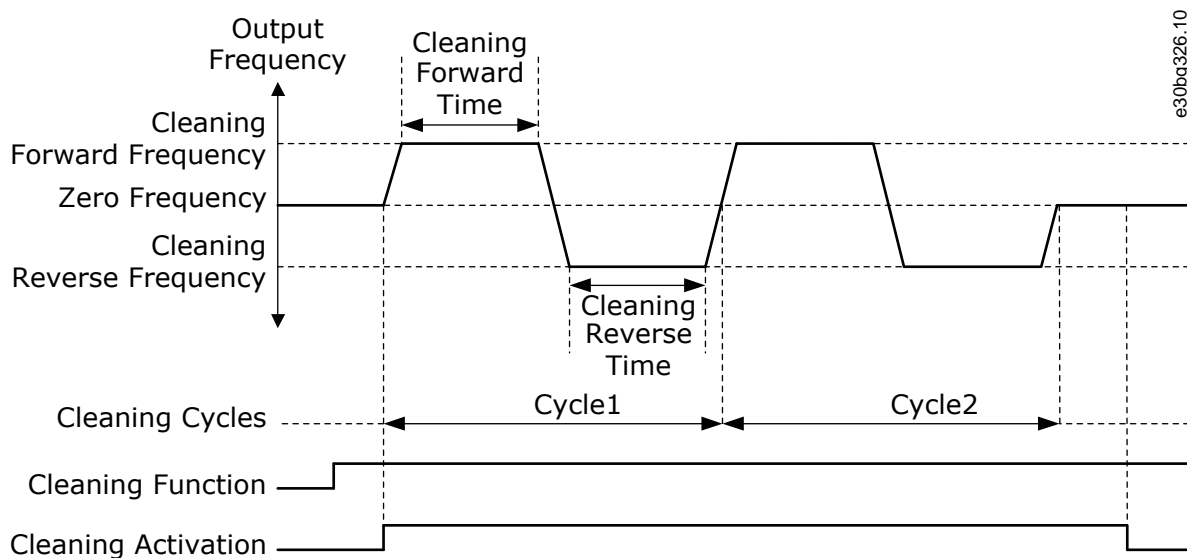

Illustration 103: The Auto-cleaning Function

11.22.2 Jockey Pump

11.22.2.1 (ID 1674) Jockey Function

Location in the menu: P3.21.2.1

Use this parameter to control the Jockey pump function. A Jockey pump is a smaller pump that keeps the pressure in the pipeline, when the main pump is in the sleep mode. It can occur, for example, in the night.

The Jockey pump function controls a jockey pump with a digital output signal. A jockey pump can be used if a PID controller is used to control the main pump. The function has 3 operation modes.

Selection number	Selection name	Description
0	Not used	
1	PID sleep	The jockey pump starts when the PID Sleep of the main pump activates. The jockey pump stops when the main pump wakes up from the sleep mode.
2	PID sleep (level)	The jockey pump starts when the PID Sleep activates, and the PID feedback signal is less than the level set by parameter P3.21.2.2. The jockey pump stops when the PID feedback signal is more than the level set in parameter P3.21.2.3 or the main pump wakes up from the sleep mode.

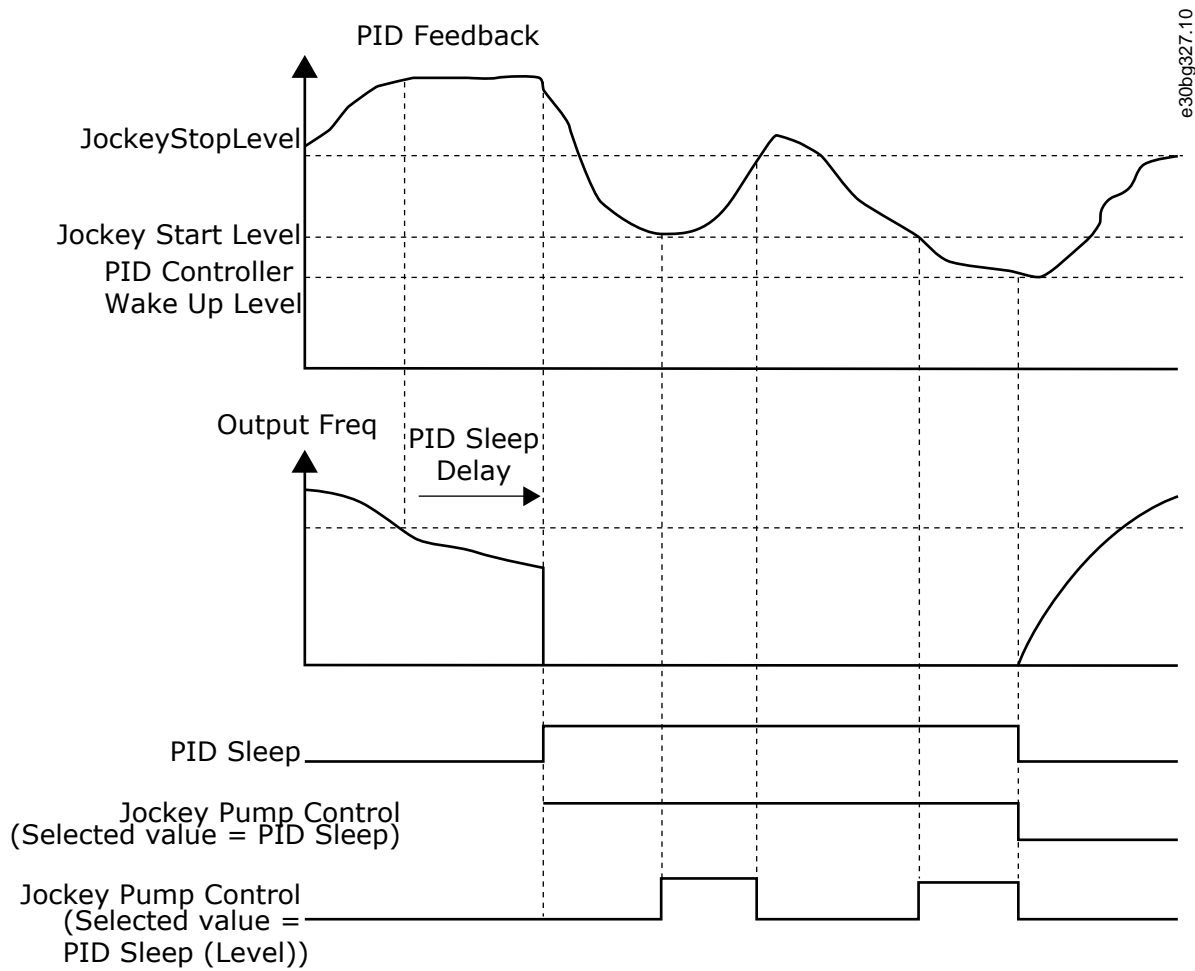

e30bg327.10

Illustration 104: The Jockey Pump Function

11.22.2.2 (ID 1675) Jockey Start Level

Location in the menu: P3.21.2.2

Use this parameter to set the level of the PID feedback signal at which the jockey pump starts when the main pump is in the sleep state. The jockey pump starts when PID Sleep is active and the PID feedback signal goes below the level set in this parameter.

This parameter is used only if P3.21.2.1 = 2 PID sleep (level).

11.22.2.3 (ID 1676) Jockey Stop Level

Location in the menu: P3.21.2.3

Use this parameter to set the level of the PID feedback signal at which the jockey pump stops when the main pump is in the sleep state.

The jockey pump stops when PID Sleep is active and the PID feedback signal goes above the level set in this parameter, or when the PID controller wakes up from sleep mode.

This parameter is used only if P3.21.2.1 = 2 PID sleep (level).

11.22.3 Priming Pump

A priming pump is a smaller pump that primes the inlet of the main pump to prevent suction of air.

The priming pump function controls a priming pump with a digital output signal. It is possible to set a delay to start the priming pump before the main pump starts. The priming pump operates continuously while the main pump operates. If the main pump goes into sleep mode, the priming pump also stops for that time. When waking up from sleep mode, the main pump, and the priming pump start simultaneously.

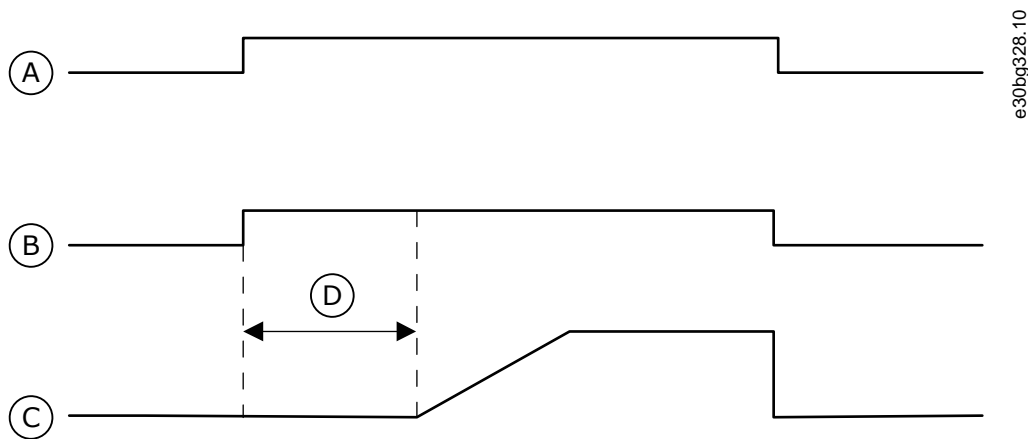

e30bg328.10

Illustration 105: The Priming Pump Function

A	Start Command (Main Pump)	C	Output Frequency (Main Pump)
B	Priming Pump Control (Digital Output Signal)	D	Priming Time

11.22.3.1 (ID 1677) Priming Function

Location in the menu: **P3.21.3.1**

Use this parameter to enable the Priming pump function. A priming pump is a smaller pump that primes the inlet of the main pump to prevent the suction of air. The priming pump function controls a priming pump with a relay output signal.

11.22.3.2 (ID 1678) Priming Time

Location in the menu: **P3.21.3.2**

Use this parameter to set the time that the priming pump operates before the main pump starts.

11.22.4 Anti-blocking Function

The Anti-blocking function makes the pump not to get blocked if the pump is stopped in the Sleep mode for a long time. The pump starts at intervals, while it is in the Sleep mode. It is possible to make a configuration of the interval, run-time, and speed for the anti-blocking.

11.22.4.1 (ID 1696) Anti-blocking Interval

Location in the menu: **P3.21.4.1**

Use this parameter to set the interval for the Anti-blocking function. This parameter gives the time after which the pump starts at the specified speed (P3.21.4.3 Anti-blocking Frequency) and for the specified quantity time (P3.21.4.2 Anti-blocking Run-time).

The Anti-blocking function can be used in the Single drive and the Multidrive systems only when the pump is in the sleep mode, or in the standby mode (Multidrive system).

The Anti-blocking function is enabled when the value of this parameter is more than 0 and disabled when the value is 0.

11.22.4.2 (ID 1697) Anti-blocking Run-time

Location in the menu: **P3.21.4.2**

Use this parameter to set the time that the pump operates at the set speed when the Antiblocking function is activated.

11.22.4.3 (ID 1504) Anti-blocking Frequency

Location in the menu: **P3.21.4.3**

Use this parameter to set the frequency reference of the drive that is used when the antiblocking function is activated.

11.22.5 Frost Protection

Use the Frost protection function to protect the pump from frost damages. If the pump is in sleep mode and the temperature that is measured in the pump goes below the set protection temperature, operate the pump at a constant frequency. Constant frequency is set in P3.13.10.6 Frost Protection Frequency. To use the function, a temperature transducer, or a temperature sensor must be installed on the pump covering or on the pipe line near the pump.

11.22.5.1 (ID 1704) Frost Protection

Location in the menu: **P3.21.5.1**

Use this parameter to enable the Frost Protection function. If the measured temperature of the pump goes below the set level and the drive is in sleep state, the frost protection makes the pump start and operate at a constant frequency.

11.22.5.2 (ID 1705) Temperature Signal

Location in the menu: **P3.21.5.2**

Use this parameter to select the source of the temperature signal that is used for the Frost Protection function.

11.22.5.3 (ID 1706) Temperature Signal Minimum

Location in the menu: **P3.21.5.3**

Use this parameter to set the minimum value of the temperature signal. For example, a temperature signal range of 4...20 mA agrees to the temperature of -50...200 °C.

11.22.5.4 (ID 1707) Temperature Signal Maximum

Location in the menu: **P3.21.5.4**

Use this parameter to set the maximum value of the temperature signal. For example, a temperature signal range of 4...20 mA agrees to the temperature of -50...200 °C.

11.22.5.5 (ID 1708) Frost Protection Temperature Limit

Location in the menu: **P3.21.5.5**

Use this parameter to set the temperature limit at which the drive starts. If the temperature of the pump goes below this limit and the drive is in the sleep state, the frost protection function starts the drive.

11.22.5.6 (ID 1710) Frost Protection Frequency

Location in the menu: **P3.21.5.6**

Use this parameter to set the frequency reference of the drive that is used when the frost protection function is activated.

11.22.5.7 (ID 1711) Frost Temperature Monitoring

Location in the menu: **P3.21.5.7**

This monitoring value shows the value of the temperature signal that is used for Frost Protection function.

11.22.6 Flow Switch

11.22.6.1 (ID 15590) Flow Switch

Location in the menu: **P3.21.6.1**

Use this parameter to select the digital input signal that is the feedback signal from the Flow Switch.

11.22.6.2 (ID 15585) Flow Switch Fault Delay

Location in the menu: **P3.21.6.2**

Use this parameter to set the time that the feedback signal from Flow Switch must stay inactive before the Flow Switch fault occurs.

11.22.6.3 (ID 15586) Flow Switch Bypass at Start

Location in the menu: **P3.21.6.3**

Use this parameter to set the time after which the Flow Switch supervision becomes active at the start-up of the drive.

11.22.6.4 (ID 15587) Flow Switch Minimum Frequency

Location in the menu: **P3.21.6.4**

Use this parameter to set the output frequency level below which the Flow Switch supervision is disabled.

11.23 Advanced Harmonic Filter

11.23.1 (ID 15510) Capacitor Disconnection Limit

Use this parameter to set the disconnection limit for the advanced harmonic filter. The value is in percentage of the drive nominal power.

11.23.2 (ID 15511) Capacitor Disconnection Hysteresis

Use this parameter to set the disconnection hysteresis for the advanced harmonic filter. The value is in percentage of the drive nominal power.

11.23.3 (ID 15513) AHF Over Temperature

- Location in the menu: **P3.5.1.59** (In I/O Configuration parameter menu)
- Location in the menu: **P3.23.3** (In Advanced Harmonic Filter parameter menu)

Use this parameter to set the digital input signal that activates AHF Over Temp (fault ID 1118).

11.23.4 (ID 15512) AHF Fault Response

Use this parameter to select the response of the AC drive to an AHF Over Temp fault.

11.24 Condition-based Monitoring

11.24.1 Introduction to Condition-based Monitoring

Condition-based monitoring in VACON® 100 drives is launched as a factory-flashed licensed firmware, embedded within the drive.

Benefits of installing the condition-based monitoring firmware are as follows:

- Reduces unexpected downtime.
- Optimizes drive or motor working conditions.
- Eliminates unexpected halts in production.

Condition-based monitoring enables regularly checks of the condition and performance of the machine when the drive is in service and detects mechanical, motor, or application failures in advance. Corrective actions can be performed before the process or application is impacted. Alarm/fault or warnings are triggered in the drive to notify customers or service technicians. Some of the corrective actions include replacement of faulty motors or bearings and ensuring the motor is running within optimal conditions.

Following are the monitoring capabilities introduced:

- **Motor stator winding monitoring:** During monitoring, inter-turn short circuit or unbalance in the motor winding is detected in advance. Damage caused by motor stator winding isolation occurs over time. When more winding turns are impacted, the over-current protection is activated due to extensive heating and stops the motor.
- **Vibration monitoring:** With the help of external sensors, the drive can monitor vibration levels in a motor. Vibrations affect motor control and can lead to motor failure. During monitoring, early detection of motor misalignment is detected and wear and tear of mechanical parts are identified earlier.
NOTE! ISO 10816 standard provides guidance for evaluating vibration severity for machines operating within 10–200 Hz of frequency range. The standard must be complied with before commissioning of vibration monitoring function.
- **Load envelope:** Mechanical load of an application is monitored by comparing current load curve with expected load curve based on data gathered during commissioning. During monitoring, overload and underload deviations which occur in applications are detected.

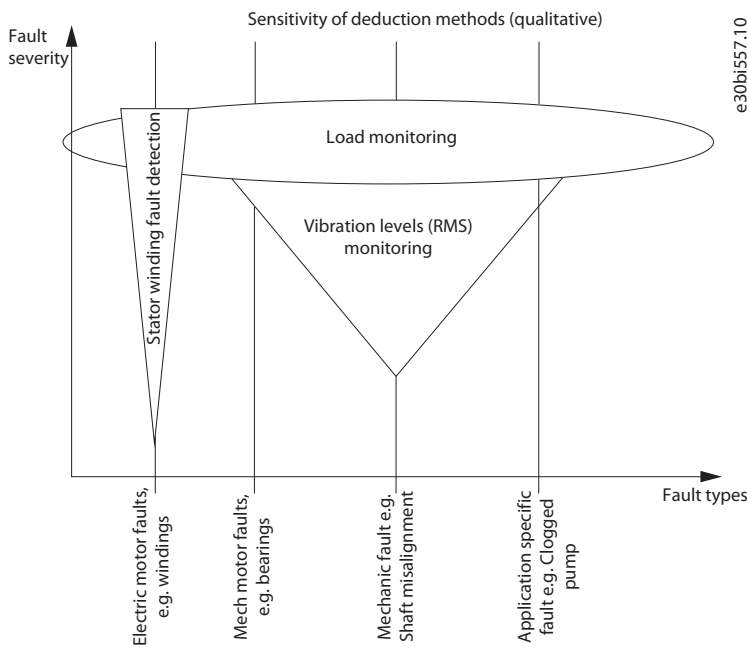

Illustration 106: Condition-based Monitoring

11.24.1.1 Stages of Condition-based Monitoring

The following figure describes the different stages of Condition-based Monitoring.

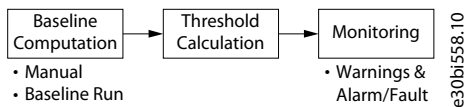

Illustration 107: Stages of Condition-based Monitoring

- **Baseline Computation:** During the initial stage, baselines for different types of condition-based monitoring are computed, based on the type of baseline mode selected.
- **Threshold Calculation:** Once the baseline is computed, the thresholds for warnings (stage 1 and stage 2) and alarm/fault are computed based on the warning or alarm/fault mode. The threshold and mode are set via parameters.
- **Monitoring:** After the thresholds are calculated, condition-based monitoring begins. Alarm/fault and warnings are triggered during deviations to notify customers.

To begin condition-based monitoring, a baseline must be generated. During this activity, the system captures motor stator winding speed points for each baseline. Define the duration, minimum and maximum speed for baseline generation. During baseline generation, 10 speed points are captured. The first and last speed point is captured based on the defined minimum and maximum speed respectively.

When speed points are not captured properly, baseline generation fails, then a new baseline has to be generated. The baseline serves as a reference for threshold limits. Using parameters, select the type of baseline measurement.

- **Baseline Run:** The drive controls the motor speed and monitors required values to derive a baseline. The drive creates a speed profile for baseline measurement. The drive interrupts the application during baseline run to operate on the speed profile created for baseline measurement. The duration for baseline calculation can be specified. Baseline measurements can copy to other drive or return to same drive after factory reset.
- **Manual Run:** The measurement points can be manually configured directly through modified parameters. Manual run can be made before or after baseline run.

11.24.2 (ID 3501) BaselineRun Start

Location in the menu: **P3.24.2.1**

Use this parameter to activate baseline run.

Baseline run is made before normal operation. Idea is to compare actual measurements with measurements taken when the system was in healthy/normal condition. The measurements from healthy condition are called "baseline".

In baseline run, the measurements of the motor current unbalance for stator winding, vibration, and motor torque are collected.

The baseline run goes through 10 frequency points including 10 steady and 9 ramp states. It collects the minimum, maximum, mean, and standard deviation values, and stores the statistical baseline data in arrays. Normal start command is required after baseline run start.

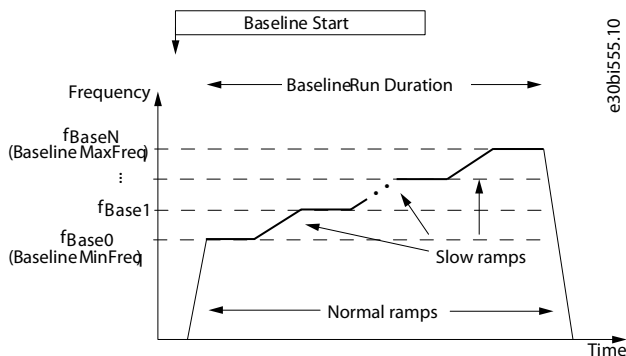

Illustration 108: BaselineRun Start

11.24.3 (ID 3502) BaselineRun MinFreq

Location in the menu: **P3.24.2.2**

Use this parameter to set frequency point where baseline run is started.

11.24.4 (ID 3503) BaselineRun MaxFreq

Location in the menu: **P3.24.2.3**

Use this parameter to set frequency point where baseline run is ended.

11.24.5 (ID 3504) BaselineRun Duration

Location in the menu: **P3.24.2.4**

Use this parameter to set the duration of the baseline run.

11.24.6 Manual Run

Before or after baseline run, each measurement point can be modified by parameter. One array includes 10 points in steady state and 9 points in ramp state.

11.24.6.1 (ID 3506) Modified Array

Location in the menu: **P3.24.2.5**

Use this parameter to select a modified array.

11.24.6.2 (ID 3507) Modified Point

Location in the menu: **P3.24.2.6**

Use this parameter to select which measurement point to modify in the array. Steady array includes 10 points and ramp array includes 9 points. First point has value 0.

11.24.6.3 (ID 3508) Modified Value

Location in the menu: **P3.24.2.7**

Use this parameter to give new value to the point selected with *ID 3507*.

11.24.6.4 (ID 3505) Modified Activation

Location in the menu: **P3.24.2.8**

Before or after the baseline run, each measurement point can be modified. Use this parameter to activate the *Modified value (ID 3508)* of the *Modified point (ID 3507)*.

11.24.6.5 (ID 3509) Baseline Data Selector

Location in the menu: **P3.24.2.9**

Use this parameter to select which array points can be monitored in monitor group *M2.16.1 Baseline data*.

11.24.6.6 (ID 3540) Condition-based Monitoring Fault Mode

Location in the menu: **P3.24.1**

Use this parameter to set the response of the drive to Exception.

Selection number	Selection name	Description
0	No Action	
1	Warnings	Warning levels S1 and S2 are used.
2	Fault + Warnings	Warning S1, warning S2 and alarm/fault levels are used.

11.24.7 Stator Winding Monitoring

For stator winding monitoring, the motor currents are being evaluated for evolving unbalances. For this purpose, current unbalance is computed and monitored. If there are the unbalanced grid voltages, a resonance-like oscillation can occur if the motor frequency matches the grid frequency.

11.24.7.1 (ID 1913) Line Freq

Location in the menu: **P3.24.3.1**

Use this parameter to set the grid Nominal Frequency.

11.24.7.2 (ID 1914) Line Freq Hysteresis

Location in the menu: **P3.24.3.2**

Use this parameter to set the hysteresis of the grid Nominal Frequency. Stator winding monitoring is not used in the hysteresis area.

11.24.8 Threshold Value

The several statistical data points (mean, minimum, maximum, and standard) from the baseline model can be combined one threshold value.

Threshold value = MeanFactor * mean + MinFactor * min + MaxFactor * max + StdFactor * stddev

11.24.8.1 (ID 3511) Current Mean Factor

Location in the menu: **P3.24.3.3.1.1**

Use this parameter to set the mean factor in the threshold value. If the threshold value is zero, the mean factor is not used.

11.24.8.2 (ID 3512) Current Min Factor

Location in the menu: **P3.24.3.3.1.2**

Use this parameter to set min factor in the threshold value. If the threshold value is zero, the min factor is not used.

11.24.8.3 (ID 3513) Current Max Factor

Location in the menu: **P3.24.3.3.1.3**

Use this parameter to set the max factor in the threshold value. If the threshold value is zero, the max factor is not used.

11.24.8.4 (ID 3514) Current Std Factor

Location in the menu: **P3.24.3.3.1.4**

Use this parameter to set the std factor in the threshold value. If the threshold value is zero, the std factor is not used.

11.24.8.5 (ID 3515) Current Interpolation Type

Location in the menu: **P3.24.3.3.1.5**

Use this parameter to select interpolation type for the notification threshold values across frequency points.

11.24.8.6 (ID 3550) Vibration Mean Factor

Location in the menu: **P3.24.4.2.1**

Use this parameter to set the mean factor in the threshold value. If the threshold value is zero, the mean factor is not used.

11.24.8.7 (ID 3551) Vibration Min Factor

Location in the menu: **P3.24.4.2.2**

Use this parameter to set the min factor in the threshold value. If the threshold value is zero, the min factor is not used.

11.24.8.8 (ID 3552) Vibration Max Factor

Location in the menu: **P3.24.4.2.3**

Use this parameter to set the max factor in the threshold value. If the threshold value is zero, the max factor is not used.

11.24.8.9 (ID 3553) Vibration Std Factor

Location in the menu: **P3.24.4.2.4**

Use this parameter to set the std factor in the threshold value. If the threshold value is zero, the std factor is not used.

11.24.8.10 (ID 3554) Vibration Interpolation Type

Location in the menu: **P3.24.4.2.5**

Use this parameter to select interpolation type for the notification threshold values across frequency points.

11.24.8.11 (ID 3567) Load Mean Factor

Location in the menu: **P3.24.5.1.1**

Use this parameter to set the mean factor in the threshold value. If the threshold value is zero, the mean factor is not used.

11.24.8.12 (ID 3568) Load Min Factor

Location in the menu: **P3.24.5.1.2**

Use this parameter to set the min factor in the threshold value. If the threshold value is zero, the min factor is not used.

11.24.8.13 (ID 3569) Load Max Factor

Location in the menu: **P3.24.5.1.3**

Use this parameter to set the max factor in the threshold value. If the threshold value is zero, the max factor is not used.

11.24.8.14 (ID 3570) Load Std Factor

Location in the menu: **P3.24.5.1.4**

Use this parameter to set the std factor in the threshold value. If the threshold value is zero, the std factor is not used.

11.24.8.15 (ID 3571) Load Interpolation Type

Location in the menu: **P3.24.5.1.5**

Use this parameter to select interpolation type for the notification threshold values across frequency points.

11.24.9 Warning and Alarm/Fault Stages

Each of the three detection levels (Warning S1, Warning S2, Alarm/Fault) has a configurable timer associated that delays the response. The timing principle is like an electrical fuse where the response time is long for low levels and it is short for high levels.

11.24.9.1 (ID 3516) Current Warning S1 Mode

Location in the menu: **P3.24.3.3.2.1**

Use this parameter to select the warning S1 mode which is used for calculating warning S1 notification threshold.

Selection number	Selection name	Description
0	Absolute	Absolute value is considered as threshold
1	Offset	Calculates threshold as sum of the computed baseline data and the offset values
2	Factor	Calculates threshold as baseline data factor

11.24.9.2 (ID 3517) Current Warning S1 High

Location in the menu: **P3.24.3.3.2.2**

Use this parameter to set the threshold value for computing the warning 1 high notification threshold. Threshold value range varies based on warning mode selection. This limit is not used when value is zero.

11.24.9.3 (ID 3518) Current Warning S1 Delay

Location in the menu: **P3.24.3.3.2.3**

Use this parameter to define how long time the actual value must be above the warning S1 notification level to trigger the warning S1. This level is not used when delay is zero.

11.24.9.4 (ID 3519) Current Warning S2 Mode

Location in the menu: **P3.24.3.3.2.4**

Use this parameter to select the warning S2 mode which is used for calculating warning S2 notification threshold.

Selection number	Selection name	Description
0	Absolute	Absolute value is considered as threshold
1	Offset	Calculates threshold as sum of the computed baseline data and the offset values
2	Factor	Calculates threshold as baseline data factor

11.24.9.5 (ID 3520) Current Warning S2 High

Location in the menu: **P3.24.3.3.2.5**

Use this parameter to set the threshold value for computing the warning 2 high notification threshold. Threshold value range varies based on warning mode selection. This limit is not used when value is zero.

11.24.9.6 (ID 3521) Current Warning S2 Delay

Location in the menu: **P3.24.3.3.2.6**

Use this parameter to define how long time the actual value must be above the warning S2 notification level to trigger the warning S2. This level is not used when delay is zero.

11.24.9.7 (ID 3522) Current Alarm/Fault Mode

Location in the menu: **P3.24.3.3.2.7**

Use this parameter to select the alarm/fault mode which is used for calculating alarm/fault notification threshold.

Selection number	Selection name	Description
0	Absolute	Absolute value is considered as threshold
1	Offset	Calculates threshold as sum of the computed baseline data and the offset values
2	Factor	Calculates threshold as baseline data factor

11.24.9.8 (ID 3523) Current Alarm/Fault High

Location in the menu: **P3.24.3.3.2.8**

Use this parameter to set the threshold value for computing the alarm/fault high notification threshold. Threshold value range varies based on alarm/fault mode selection. This limit is not used when value is zero.

11.24.9.9 (ID 3524) Current Alarm/Fault Delay

Location in the menu: **P3.24.3.3.2.9**

Use this parameter to define how long time the actual value must be above the alarm/fault notification level to trigger the alarm/fault. This level is not used when delay is zero.

11.24.9.10 (ID 3541) Current Warning S1 Counter

Location in the menu: **P3.24.3.3.3.1**

Use this parameter to set warning S1 counter value.

11.24.9.11 (ID 3542) Current Warning S2 Counter

Location in the menu: **P3.24.3.3.3.2**

Use this parameter to set warning S2 counter value.

11.24.9.12 (ID 3543) Current Alarm/Fault Counter

Location in the menu: **P3.24.3.3.3.3**

Use this parameter to set alarm/fault counter value.

11.24.9.13 (ID 3549) Stop Counter Delay

Location in the menu: **P3.24.2.3.4, P3.24.4.4.4, and P3.24.5.3.4**

Location in the menu: **P3.23.2.3.4, P3.23.4.4.4, and P3.23.5.3.4**

Use this parameter to set stop counter. The counter is stopped if threshold value is outside of the limit below this time.

11.24.9.14 (ID 3555) Vibration Warning S1 Mode

Location in the menu: **P3.24.4.3.1**

Use this parameter to select the warning S1 mode which is used for calculating warning S1 notification threshold.

Selection number	Selection name	Description
0	Absolute	Absolute value is considered as threshold
1	Offset	Calculates threshold as sum of the computed baseline data and the offset values
2	Factor	Calculates threshold as baseline data factor

11.24.9.15 (ID 3556) Vibration Warning S1 High

Location in the menu: **P3.24.4.3.2**

Use this parameter to set the threshold value for computing the warning 1 high notification threshold. Threshold value range varies based on warning mode selection. This limit is not used when value is zero.

11.24.9.16 (ID 3557) Vibration Warning S1 Delay

Location in the menu: **P3.24.4.3.3**

Use this parameter to define how long time the actual value must be above the warning S1 notification level to trigger the warning S1. This level is not used when delay is zero.

11.24.9.17 (ID 3558) Vibration Warning S2 Mode

Location in the menu: **P3.24.4.3.4**

Use this parameter to select the warning S2 mode which is used for calculating warning S2 notification threshold.

Selection number	Selection name	Description
0	Absolute	Absolute value is considered as threshold
1	Offset	Calculates threshold as sum of the computed baseline data and the offset values
2	Factor	Calculates threshold as baseline data factor

11.24.9.18 (ID 3559) Vibration Warning S2 High

Location in the menu: **P3.24.4.3.5**

Use this parameter to set the threshold value for computing the warning 2 high notification threshold. Threshold value range varies based on warning mode selection. This limit is not used when value is zero.

11.24.9.19 (ID 3560) Vibration Warning S2 Delay

Location in the menu: **P3.24.4.3.6**

Use this parameter to define how long time the actual value must be above the warning S2 notification level to trigger the warning S2. This level is not used when delay is zero.

11.24.9.20 (ID 3561) Vibration Alarm/Fault Mode

Location in the menu: **P3.24.4.3.7**

Use this parameter to select the alarm/fault mode which is used for calculating alarm/fault notification threshold.

Selection number	Selection name	Description
0	Absolute	Absolute value is considered as threshold
1	Offset	Calculates threshold as sum of the computed baseline data and the offset values
2	Factor	Calculates threshold as baseline data factor

11.24.9.21 (ID 3562) Vibration Alarm/Fault High

Location in the menu: **P3.24.4.3.8**

Use this parameter to set the threshold value for computing the alarm/fault high notification threshold. Threshold value range varies based on warning mode selection. This limit is not used when value is zero.

11.24.9.22 (ID 3563) Vibration Alarm/Fault Delay

Location in the menu: **P3.24.4.3.9**

Use this parameter to define how long time the actual value must be above the alarm/fault notification level to trigger the alarm/fault. This level is not used when delay is zero.

11.24.9.23 (ID 3564) Vibration Warning S1 Counter

Location in the menu: **P3.24.4.4.1**

Use this parameter to set warning S1 counter value.

11.24.9.24 (ID 3565) Vibration Warning S2 Counter

Location in the menu: **P3.24.4.4.2**

Use this parameter to set warning S2 counter value.

11.24.9.25 (ID 3566) Vibration Alarm/Fault Counter

Location in the menu: **P3.24.4.4.3**

Use this parameter to set alarm/fault counter value.

11.24.9.26 (ID 3572) Load Warning S1 Mode

Location in the menu: **P3.24.5.2.1**

Use this parameter to select the warning S1 mode which is used for calculating warning S1 notification threshold.

Selection number	Selection name	Description
0	Absolute	Absolute value is considered as threshold
1	Offset	Calculates threshold as sum of the computed baseline data and the offset values
2	Factor	Calculates threshold as baseline data factor

11.24.9.27 (ID 3573) Load Warning S1 High

Location in the menu: **P3.24.5.2.3**

Use this parameter to set the threshold value for computing the warning 1 high notification threshold. Threshold value range varies based on warning mode selection. This limit is not used when value is zero.

11.24.9.28 (ID 3574) Load Warning S1 Delay

Location in the menu: **P3.24.5.2.4**

Use this parameter to define how long time the actual value must be above the warning S1 notification level to trigger the warning S1. This level is not used when delay is zero.

11.24.9.29 (ID 3575) Load Warning S2 Mode

Location in the menu: **P3.24.5.2.5**

Use this parameter to select the warning S2 mode which is used for calculating warning S2 notification threshold.

Selection number	Selection name	Description
0	Absolute	Absolute value is considered as threshold
1	Offset	Calculates threshold as sum of the computed baseline data and the offset values
2	Factor	Calculates threshold as baseline data factor

11.24.9.30 (ID 3576) Load Warning S2 High

Location in the menu: **P3.24.5.2.7**

Use this parameter to set the threshold value for computing the warning 2 high notification threshold. Threshold value range varies based on warning mode selection. This limit is not used when value is zero.

11.24.9.31 (ID 3577) Load Warning S2 Delay

Location in the menu: **P3.24.5.2.8**

Use this parameter to define how long time the actual value must be above the warning S2 notification level to trigger the warning S2. This level is not used when delay is zero.

11.24.9.32 (ID 3578) Load Alarm/Fault Mode

Location in the menu: **P3.24.5.2.9**

Use this parameter to select the alarm/fault mode which is used for calculating alarm/fault notification threshold.

Selection number	Selection name	Description
0	Absolute	Absolute value is considered as threshold
1	Offset	Calculates threshold as sum of the computed baseline data and the offset values
2	Factor	Calculates threshold as baseline data factor

11.24.9.33 (ID 3579) Load Alarm/Fault High

Location in the menu: **P3.24.5.2.11**

Use this parameter to set the threshold value for computing the alarm/fault high notification threshold. Threshold value range varies based on warning mode selection. This limit is not used when value is zero.

11.24.9.34 (ID 3580) Load Alarm/Fault Delay

Location in the menu: **P3.24.5.2.12**

Use this parameter to define how long time the actual value must be above the alarm/fault notification level to trigger the alarm/fault. This level is not used when delay is zero.

11.24.9.35 (ID 3581) Load Warning S1 Counter

Location in the menu: **P3.24.5.3.1**

Use this parameter to set warning S1 counter value.

11.24.9.36 (ID 3582) Load Warning S2 Counter

Location in the menu: **P3.24.5.3.2**

Use this parameter to set warning S2 counter value.

11.24.9.37 (ID 3583) Load Alarm/Fault Counter

Location in the menu: **P3.24.5.3.3**

Use this parameter to set alarm/fault counter value.

11.24.9.38 (ID 3584) Load Warning S1 Low

Location in the menu: **P3.24.5.2.2**

Use this parameter to set the threshold value for computing the warning 1 low notification threshold. Threshold value range varies based on warning mode selection. This limit is not used when value is zero.

11.24.9.39 (ID 3585) Load Warning S2 Low

Location in the menu: **P3.24.5.2.6**

Use this parameter to set the threshold value for computing the warning 2 low notification threshold. Threshold value range varies based on warning mode selection. This limit is not used when value is zero.

11.24.9.40 (ID 3586) Load Alarm/Fault Low

Location in the menu: **P3.24.5.2.10**

Use this parameter to set the threshold value for computing the alarm/fault low notification threshold. Threshold value range varies based on warning mode selection. This limit is not used when value is zero.

11.24.10 (ID 3587) Vibration Input

Location in the menu: **P3.24.4.1**

Use this parameter to select the analog input to vibration.

11.25 Default Values of Parameters in the Different Applications

Table 132: Default Values of Parameters of Group 3.2

Index	Parameter	Standard application	HVAC application	PID control application	Multi-pump (single drive) application	Multi-pump (multidrive) application	Unit	ID	Description
3.2.1	Rem Control Place	0	0	0	0	0		172	0 = I/O Control
3.2.2	Local/Remote	0	0	0	0	0		211	0 = Remote
3.2.6	I/O A Logic	2	2	2	0	0		300	2 = Forw-Back (edge)
3.2.7	I/O B Logic	2	2	2	2	2		363	2 = Forw-Back (edge)

Table 133: Default Values of Parameters of Group 3.3

Index	Parameter	Standard application	HVAC application	PID control application	Multi-pump (single drive) application	Multi-pump (multi-drive) application	Unit	ID	Description
3.3.1.5	I/O A Ref Sel	6	6	7	7	7		117	6 = AI1 + AI2 7 = PID
3.3.1.6	I/O B Ref Sel	4	4	4	4	4		131	4 = AI1
3.3.1.7	Keypad Ref Sel	2	2	2	2	2		121	2 = Keypad Reference
3.3.1.10	Fieldbus Ref Sel	3	3	3	3	3		122	3 = Fieldbus Reference
3.3.3.1	Preset Freq Mode	0	0	0	0	0		182	0 = Binary Coded
3.3.3.3	Preset Freq 1	10.0	10.0	10.0	10.0	10.0	Hz	105	
3.3.3.4	Preset Freq 2	15.0	15.0	15.0	15.0	15.0	Hz	106	
3.3.3.5	Preset Freq 3	20.0	20.0	20.0	20.0	20.0	Hz	126	
P3.3.6.1	Flushing Reference Activation	0	0	0	0	101		530	0 = DigIN Slot0.1 101 = DigIN SlotA.2
P3.3.6.2	Flushing Reference	0	0	0	0	0	Hz	1239	

Table 134: Default Values of Parameters of Group 3.5

Index	Parameter	Standard application	HVAC application	PID control application	Multi-pump (single drive) application	Multi-pump (multi-drive) application	Unit	ID	Description
3.5.1.1	Ctrl Signal 1 A	100	100	100	100	100		403	100 = DigIN SlotA.1
3.5.1.2	Ctrl Signal 2 A	101	101	0	0	0		404	0 = DigIN Slot0.1 101 = DigIN SlotA.2
3.5.1.4	Ctrl Signal 1 B	0	0	103	101	0		423	0 = DigIN Slot0.1 101 = DigIN SlotA.2 103 = DigIN SlotA.4
3.5.1.7	I/O B Ctrl Force	0	0	105	102	0		425	0 = DigIN Slot0.1 102 = DigIN SlotA.3 105 = DigIN SlotA.6
3.5.1.8	I/O B Ref Force	0	0	105	102	0		343	0 = DigIN Slot0.1 102 = DigIN SlotA.3 105 = DigIN SlotA.6

Index	Parameter	Standard application	HVAC application	PID control application	Multi-pump (single drive) application	Multi-pump (multi-drive) application	Unit	ID	Description
3.5.1.9	Fieldbus Ctrl Force	0	0	0	0	0		411	
3.5.1.10	Keypad Ctrl Force	0	0	0	0	0		410	
3.5.1.11	External Fault Close	102	102	101	0	105		405	0 = DigIN Slot0.1 101 = DigIN SlotA.2 102 = DigIN SlotA.3 105 = DigIN SlotA.6
3.5.1.13	Fault Reset Close	105	105	102	0	103		414	0 = DigIN Slot0.1 102 = DigIN SlotA.3 103 = DigIN SlotA.4 105 = DigIN SlotA.6
3.5.1.21	Preset Freq Sel0	103	103	104	0	0		419	0 = DigIN Slot0.1 103 = DigIN SlotA.4 104 = DigIN SlotA.5
3.5.1.22	Preset Freq Sel1	104	104	0	0	0		420	0 = DigIN Slot0.1 104 = DigIN SlotA.5
3.5.1.23	Preset Freq Sel2	0	0	0	0	0		421	
P3.5.1.31	PID Setpoint Selection	0	0	0	0	102		1047	0 = DigIN Slot0.1 102 = DigIN SlotA.3
P3.5.1.36	Flushing Reference Activation	0	0	0	0	101		530	0 = DigIN Slot0.1 101 = DigIN SlotA.2
P3.5.1.42	Pump 1 Interlock	0	0	0	103	0		426	0 = DigIN Slot0.1 103 = DigIN SlotA.4
P3.5.1.43	Pump 2 Interlock	0	0	0	104	0		427	0 = DigIN Slot0.1 104 = DigIN SlotA.5
P3.5.1.44	Pump 3 Interlock	0	0	0	105	0		428	0 = DigIN Slot0.1 105 = DigIN SlotA.6
3.5.2.1.1	AI1 Signal Selection	100	100	100	100	100		377	100 = AnIN SlotA.1
3.5.2.1.2	AI1 Filter Time	0.1	0.1	0.1	0.1	0.1	s	378	
3.5.2.1.3	AI1 Signal Range	0	0	0	0	0		379	0 = 0...10 V/0...20 mA
3.5.2.1.4	AI1 Custom Min	0.0	0.0	0.0	0.0	0.0	%	380	
3.5.2.1.5	AI1 Custom Max	100.0	100.0	100.0	100.0	100.0	%	381	

Index	Parameter	Standard application	HVAC application	PID control application	Multi-pump (single drive) application	Multi-pump (multi-drive) application	Unit	ID	Description
3.5.2.1.6	AI1 Signal Inversion	0	0	0	0	0		387	
3.5.2.2.1	AI2 Signal Selection	101	101	101	101	101		388	101 = AnIN SlotA.2
3.5.2.2.2	AI2 Filter Time	0.1	0.1	0.1	0.1	0.1	s	389	
3.5.2.2.3	AI2 Signal Range	1	1	1	1	1		390	1 = 2...10 V/4...20 mA
3.5.2.2.4	AI2 Custom Min	0.0	0.0	0.0	0.0	0.0	%	391	
3.5.2.2.5	AI2 Custom Max	100.0	100.0	100.0	100.0	100.0	%	392	
3.5.2.2.6	AI2 Signal Inversion	0	0	0	0	0		398	
3.5.3.2.1	RO1 Function	2	2	2	49	2		11001	2 = Run
3.5.3.2.4	RO2 Function	3	3	3	50	3		11004	3 = Fault
3.5.3.2.7	RO3 Function	1	1	1	51	1		11007	1 = Ready
3.5.4.1.1	AO1 Function	2	2	2	2	2		10050	2 = Output Freq
3.5.4.1.2	AO1 Filter Time	1.0	1.0	1.0	1.0	1.0	s	10051	
3.5.4.1.3	AO1 Min Signal	0	0	0	0	0		10052	
3.5.4.1.4	AO1 Min Scale	0.0	0.0	0.0	0.0	0.0		10053	
3.5.4.1.5	AO1 Max Scale	0.0	0.0	0.0	0.0	0.0		10054	

Table 135: Default Values of Parameters of Group 3.10

Index	Parameter	Standard application	HVAC application	PID control application	Multi-pump (single drive) application	Multi-pump (multidrive) application	Unit	ID	Description
P3.10.1	Automatic Reset	0	0	1	1	1		731	0 = Disabled 1 = Enabled

Table 136: Default Values of Parameters of Group 3.13

Index	Parameter	Standard application	HVAC application	PID control application	Multi-pump (single drive) application	Multi-pump (multi-drive) application	Unit	ID	Description
P3.13.2.5	PID Setpoint Selection	0	0	0	102			1047	0 = DigIN Slot0.1

Index	Parameter	Standard application	HVAC application	PID control application	Multi-pump (single drive) application	Multi-pump (multi-drive) application	Unit	ID	Description
									102 = DigIN SlotA.3
3.13.2.6	PID Setpoint Source 1	-	-	1	1	1		332	1 = Keypad Setpoint 1
P3.13.2.10	PID Setpoint Source 2	-	-	-	-	2		431	2 = Keypad Setpoint 2
3.13.3.1	PID Feedback Function	-	-	1	1	1		333	1 = Only Source 1 in use
3.13.3.3	PID Feedback Source	-	-	2	2	2		334	2 = AI2

Table 137: Default Values of Parameters of Group 3.15

Index	Parameter	Standard application	HVAC application	PID control application	Multi-pump (single drive) application	Multi-pump (multi-drive) application	Unit	ID	Description
P3.15.1	Multi-pump Mode	-	-	-	0	2		1785	0= Single drive 1= Multifollower 2= Multimaster
P3.15.2	Number of Pumps	1	1	1	3	3		1001	
P3.15.5	Pump Interlocking	-	-	-	1	1		1032	0 = Disabled 1 = Enabled
P3.15.6	Autochange	-	-	-	1	1		1027	0 = Disabled 1 = Enabled (interval) 2 = Enabled (weekdays)
P3.15.7	Autochanged Pumps	-	-	-	1	1		1028	0 = Auxiliary Pump 1 = All Pumps
P3.15.8	Autochange Interval	-	-	-	48.0	48.0	h	1029	
P3.15.11	Autochange Frequency Limit	-	-	-	25.0	25.0	Hz	1031	
P3.15.12	Autochange Pump Limit	-	-	-	1	3		1030	
P3.15.13	Bandwidth	-	-	-	10.0	10.0	%	1097	

Index	Parameter	Standard application	HVAC application	PID control application	Multi-pump (single drive) application	Multi-pump (multi-drive) application	Unit	ID	Description
P3.15.14	Bandwidth Delay	-	-	-	10	10	s	1098	
P3.15.15	Constant Production Speed	-	-	-	-	100.0	%	1513	
P3.15.16	Running Pumps Limit	-	-	-	3	3		1187	

Table 138: Default Values of Parameters of Group 5.7

Index	Parameter	Standard application	HVAC application	PID control application	Multi-pump (single drive) application	Multi-pump (multidrive) application	Unit	ID	Description
P5.7.1	Timeout time	5	5	5	5	5	min	804	
P5.7.2	Default Page	4	4	4	4	4		2318	4 = Multi-monitor

12 Fault Tracing

12.1 Fault Types

When the control diagnostics of the AC drive find an unusual condition in the operation of the drive, the drive shows a notification about it. The notification can be seen on the display of the control panel. The display shows the code, the name, and a short description of the fault or alarm.

The source info tells the source of the fault, what caused it, where it occurred, and other data.

There are 3 different types of notification.

- An **info** does not affect the operation of the drive. The info must be reset.
- An **alarm** informs of unusual operation on the drive. It does not stop the drive. The alarm must be reset.
- A **fault** stops the drive. The drive must be reset and find a solution to the problem.

It is possible to program different responses for some faults in the application. See more in [6.9 Group 3.9: Protections](#).

Reset the fault with the [BACK/RESET] button on the keypad, or through the I/O terminal, fieldbus, or PC tool. The faults stay in the Fault history where they can be examined. See the different fault codes in [12.3 Fault Codes](#).

Before contacting the distributor or the factory because of unusual operation, prepare some data. Write down all the texts on the display, the fault code, the fault ID, the source info, the *Active Faults* list, and the *Fault History*.

12.2 Alarms and Warnings

In condition-based monitoring, for each feature, the user can define activation stages for warnings and alarms. The interpretation of alarm and warning color codes are as follows:

Green: No alarms are indicated. Condition-based monitoring operations continue.

Yellow: First indication of warning-stage 1 alarm is visible. Stage 1 warning fault are also shown as *Stage 1 Warning (S1)*. Notification to users to plan for maintenance operations. In this stage, condition-based monitoring operations continue.

Orange: Clear indication of warning-stage 2 alarm is visible. Stage 2 warning fault are also shown as *Stage 2 Warning (S2)*. Notification to users to act as soon as possible before the fault becomes critical.

Red: A critical alarm has occurred and condition-based monitoring operations has stopped.

12.3 Fault Codes

12.3.1 Fault Code 1, ID 1 - Overcurrent (Hardware Fault)

Cause

There is too high a current ($> 4 \times I_H$) in the motor cable.

- a sudden heavy load increase
- a short circuit in the motor cables
- the motor is not the correct type
- the parameter settings are not properly made

Troubleshooting

- Check the loading.
- Check the motor.
- Check the cables and connections.
- Make an identification run.
- Set the acceleration time longer (P3.4.1.2 and P3.4.2.2).

12.3.2 Fault Code 1, ID 2 - Overcurrent (Software Fault)

Cause

There is too high a current ($> 4 \times I_H$) in the motor cable.

- a sudden heavy load increase
- a short circuit in the motor cables
- the motor is not the correct type
- the parameter settings are not properly made

Troubleshooting

- Check the loading.
- Check the motor.
- Check the cables and connections.
- Make an identification run.
- Set the acceleration time longer (P3.4.1.2 and P3.4.2.2).

12.3.3 Fault Code 2, ID 10 - Overvoltage (Hardware Fault)

Cause

The DC link voltage is higher than the limits.

- too short a deceleration time
- high overvoltage spikes in the supply

Troubleshooting

- Set the deceleration time longer (P3.4.1.3 and P3.4.2.3).
- Activate the overvoltage controller.
- Check the input voltage.

12.3.4 Fault Code 2, ID 11 - Overvoltage (Software Fault)

Cause

The DC link voltage is higher than the limits.

- too short a deceleration time
- high overvoltage spikes in the supply

Troubleshooting

- Set the deceleration time longer (P3.4.1.3 and P3.4.2.3).
- Activate the overvoltage controller.
- Check the input voltage.

12.3.5 Fault Code 3, ID 20 - Earth Fault (Hardware Fault)

Cause

The measurement of current tells that the sum of the motor phase current is not zero.

- an insulation malfunction in the cables or the motor
- a filter (dU/dt, sine) malfunction

Troubleshooting

- Check the motor cables and the motor.
- Check the filters.

12.3.6 Fault Code 3, ID 21 - Earth fault (Software Fault)

Cause

The measurement of current tells that the sum of the motor phase current is not zero.

- an insulation malfunction in the cables or the motor
- a filter (dU/dt, sine) malfunction

Troubleshooting

- Check the motor cables and the motor.
- Check the filters.

12.3.7 Fault Code 5, ID 40 - Charging Switch

Cause

The charging switch is closed and the feedback information is OPEN.

- operation malfunction
- defective component

Troubleshooting

- Reset the fault and restart the drive.
- Check the feedback signal and the cable connection between the control board and the power board.
- If the fault occurs again, ask for instructions from your nearest distributor.

12.3.8 Fault Code 7, ID 60 - Saturation

Cause

- Defective IGBT.
- De-saturation short circuit in the IGBT.
- A short circuit or an overload in the brake resistor.

Troubleshooting

- This fault cannot be reset from the control panel.
- Switch off the power.
- DO NOT RESTART THE DRIVE or CONNECT THE POWER!
- Ask for instructions from the factory.

12.3.9 Fault Code 8, ID 600 - System Fault

Cause

- There is no communication between the control board and the power unit.

Troubleshooting

- Reset the fault and restart the drive.
- Download the latest software from the Danfoss Drives website. Update the drive with it.
- If the fault occurs again, ask for instructions from your nearest distributor.

12.3.10 Fault Code 8, ID 601 - System Fault

Cause

- There is no communication between the control board and the power.

Troubleshooting

- Reset the fault and restart the drive.
- Download the latest software from the Danfoss Drives website. Update the drive with it.
- If the fault occurs again, ask for instructions from your nearest distributor.

12.3.11 Fault Code 8, ID 602 - System Fault

Cause

- Defective component.
- Operation malfunction.

Troubleshooting

- Reset the fault and restart the drive.
- Download the latest software from the Danfoss Drives website. Update the drive with it.
- If the fault occurs again, ask for instructions from your nearest distributor.

12.3.12 Fault Code 8, ID 603 - System Fault

Cause

- Defective component.
- Operation malfunction.
- The voltage of auxiliary power in the power unit is too low.

Troubleshooting

- Reset the fault and restart the drive.
- Download the latest software from the Danfoss Drives website. Update the drive with it.
- If the fault occurs again, ask for instructions from your nearest distributor.

12.3.13 Fault Code 8, ID 604 - System Fault

Cause

- Defective component.
- Operation malfunction.
- Output phase voltage does not agree to the reference.
- Feedback fault.

Troubleshooting

- Reset the fault and restart the drive.
- Download the latest software from the Danfoss Drives website. Update the drive with it.
- If the fault occurs again, ask for instructions from your nearest distributor.

12.3.14 Fault Code 8, ID 605 - System Fault

Cause

- Defective component.
- Operation malfunction.

Troubleshooting

- Reset the fault and restart the drive.
- Download the latest software from the Danfoss Drives website. Update the drive with it.
- If the fault occurs again, ask for instructions from your nearest distributor.

12.3.15 Fault Code 8, ID 606 - System Fault

Cause

- The software of the control unit is not compatible with the software of the power unit.

Troubleshooting

- Reset the fault and restart the drive.
- Download the latest software from the Danfoss Drives website. Update the drive with it.
- If the fault occurs again, ask for instructions from your nearest distributor.

12.3.16 Fault Code 8, ID 607 - System Fault

Cause

- The software version cannot be read. There is no software in the power unit.
- Defective component.
- Operation malfunction (a problem in the power board or the measurement board).

Troubleshooting

- Reset the fault and restart the drive.
- Download the latest software from the Danfoss Drives website. Update the drive with it.
- If the fault occurs again, ask for instructions from your nearest distributor.

12.3.17 Fault Code 8, ID 608 - System Fault

Cause

- A CPU overload.

Troubleshooting

- Reset the fault and restart the drive.
- Download the latest software from the Danfoss Drives website. Update the drive with it.
- If the fault occurs again, ask for instructions from your nearest distributor.

12.3.18 Fault Code 8, ID 609 - System Fault

Cause

- Defective component.
- Operation malfunction.

Troubleshooting

- Reset the fault and make a power down of the drive twice.
- Download the latest software from the Danfoss Drives website. Update the drive with it.

12.3.19 Fault Code 8, ID 610 - System Fault

Cause

- Defective component.
- Operation malfunction.

Troubleshooting

- Reset the fault and restart.
- Download the latest software from the Danfoss Drives website. Update the drive with it.
- If the fault occurs again, ask for instructions from your nearest distributor.

12.3.20 Fault Code 8, ID 614 - System Fault

Cause

- Configuration error.
- Software error.
- Defective component (a defective control board).
- Operation malfunction.

Troubleshooting

- Reset the fault and restart.
- Download the latest software from the Danfoss Drives website. Update the drive with it.
- If the fault occurs again, ask for instructions from your nearest distributor.

12.3.21 Fault Code 8, ID 647 - System Fault

Cause

- Defective component.
- Operation malfunction.

Troubleshooting

- Reset the fault and restart.
- Download the latest software from the Danfoss Drives website. Update the drive with it.
- If the fault occurs again, ask for instructions from your nearest distributor.

12.3.22 Fault Code 8, ID 648 - System Fault

Cause

- Operation malfunction.
- The system software is not compatible with the application.

Troubleshooting

- Reset the fault and restart.
- Download the latest software from the Danfoss Drives website. Update the drive with it.
- If the fault occurs again, ask for instructions from your nearest distributor.

12.3.23 Fault Code 8, ID 649 - System Fault

Cause

- A resource overload.
- A parameter loading, restoring or saving malfunction.

Troubleshooting

- Load the factory default settings.
- Download the latest software from the Danfoss Drives website. Update the drive with it.

12.3.24 Fault Code 8, ID 667 - System Fault

Cause

- Ethernet PHY is not recognized or it is in the wrong state.

Troubleshooting

- Reset the fault and restart the AC drive.
- Download the newest software from the Danfoss Drives website. Update the drive with it.
- If the fault occurs again, ask for instructions from your nearest distributor.

12.3.25 Fault Code 8, ID 670 - System Fault

Cause

- The output voltage is too low because of overload, a defective component, or a shortcut.

Troubleshooting

- Check the loading of the auxiliary output.
- Reset the fault and restart the AC drive.
- Download the newest software from the Danfoss Drives website. Update the drive with it.
- If the fault occurs again, ask for instructions from your nearest distributor.

12.3.26 Fault Code 8, ID 827 - System Fault

Cause

- Invalid/incorrect license key provided (via keypad or VCX).
- The license key is incorrect or not for this drive.

Troubleshooting

- Reset the fault and restart the AC drive.
- Enter the license key to the AC drive again.
- Download the newest software from the Danfoss Drives website. Update the drive with it.
- If the fault occurs again, ask for instructions from your nearest distributor.

12.3.27 Fault Code 8, ID 828 - System Fault

Cause

- The entered license key was accepted and stored to the drive.

Troubleshooting

- No actions required. Notification only.

12.3.28 Fault Code 8, ID 829 - System Fault

Cause

- New licenses have been taken into use since the previous start-up.

Troubleshooting

-

12.3.29 Fault Code 8, ID 830 - System Fault

Cause

- Licenses have been removed from the drive.

Troubleshooting

- No actions required. Notification only.

12.3.30 Fault Code 9, ID 80 - Undervoltage (Fault)

Cause

The DC link voltage is lower than the limits.

- too low a supply voltage
- defective component
- a defective input fuse
- the external charge switch is not closed

NOTE! This fault becomes active only if the drive is in Run state.

Troubleshooting

- If there is a temporary supply voltage break, reset the fault and restart the drive.
- Do a check of the supply voltage. If the supply voltage is sufficient, there is an internal fault.
- Examine the electrical network for fault.
- Ask for instructions from your nearest distributor.

12.3.31 Fault Code 10, ID 91 - Input Phase

Cause

- supply voltage malfunction
- a defective fuse or malfunction in the supply cables

The load must be a minimum of 10–20% for the supervision to work.

Troubleshooting

- Check the supply voltage.
- Check the fuses.
- Check the supply cable.
- Check the rectifying bridge.
- Check the gate control of the thyristor (MR6->).

12.3.32 Fault Code 10, ID 92 - Input Phase

Cause

- Software-based input phase supervision.

Troubleshooting

- Check the supply voltage.
- Check the fuses.
- Check the supply cable.

NOTICE

This fault is only used with enclosure sizes MR9B, MR10, MR11, and MR12.

12.3.33 Fault Code 10, ID 94 - Input Phase**Cause**

- Software-based input phase supervision.

Troubleshooting

- Check the supply voltage.
- Check the fuses.
- Check the supply cable.

NOTICE

This fault is only used with enclosure sizes MR11 and MR12.

12.3.34 Fault Code 11, ID 100 - Output Phase Supervision**Cause**

The current measurement tells that there is no current in 1 motor phase.

- A motor or motor cables malfunction.
- Filter (dU/dt, sine wave) malfunction.

Troubleshooting

- Check the motor cable and the motor.
- Check the dU/dt or sine wave filter.

12.3.35 Fault Code 13, ID 120 - AC Drive Undertemperature (Fault)**Cause**

- Too low a temperature in the heat sink of the power unit or in the power board.

Troubleshooting

- The ambient temperature is too low for the drive. Move the drive in a warmer position.

12.3.36 Fault Code 14, ID 130 - AC Drive Overtemperature (Fault, Heat Sink)**Cause**

- Too high a temperature in the heat sink of the power unit or in the power board.
- The temperature limits of the heat sink are different in all the enclosure sizes.

Troubleshooting

- Check the actual amount and flow of cooling air.
- Examine the heat sink for dust.
- Check the ambient temperature.
- Make sure that the switching frequency is not too high in relation to the ambient temperature and the motor load.
- Check the cooling fan.

12.3.37 Fault Code 14, ID 131 - AC Drive Overtemperature (Alarm, Heat Sink)**Cause**

- Too high a temperature in the heat sink of the power unit or in the power board.
- The temperature limits of the heat sink are different in all the enclosure sizes.

Troubleshooting

- Check the actual amount and flow of cooling air.
- Examine the heat sink for dust.

- Check the ambient temperature.
- Make sure that the switching frequency is not too high in relation to the ambient temperature and the motor load.
- Check the cooling fan.

12.3.38 Fault Code 14, ID 132 - AC Drive Overtemperature (Fault, Board)

Cause

- Too high a temperature in the heat sink of the power unit or in the power board.
- The temperature limits of the heat sink are different in all the enclosure sizes.

Troubleshooting

- Check the actual amount and flow of cooling air.
- Examine the heat sink for dust.
- Check the ambient temperature.
- Make sure that the switching frequency is not too high in relation to the ambient temperature and the motor load.
- Check the cooling fan.

12.3.39 Fault Code 14, ID 133 - AC Drive Overtemperature (Alarm, Board)

Cause

- Too high a temperature in the heat sink of the power unit or in the power board.
- The temperature limits of the heat sink are different in all the enclosure sizes.

Troubleshooting

- Check the actual amount and flow of cooling air.
- Examine the heat sink for dust.
- Check the ambient temperature.
- Make sure that the switching frequency is not too high in relation to the ambient temperature and the motor load.
- Check the cooling fan.

12.3.40 Fault Code 14, ID 134 - AC Drive Overtemperature (Fault)

Cause

- Power unit auxiliary temperature is too high.

Troubleshooting

- Check the actual amount and flow of cooling air.
- Examine the heat sink for dust.
- Check the ambient temperature.
- Make sure that the switching frequency is not too high in relation to the ambient temperature and the motor load.
- Check the cooling fan.

12.3.41 Fault Code 14, ID 136 - Overvoltage Protection Circuit Temperature (Alarm)

Cause

- Too high an output capacitance or a ground fault in the floating network.

Troubleshooting

- Check the cables and the motor.

12.3.42 Fault Code 14, ID 137 - Overvoltage Protection Circuit Temperature (Fault)

Cause

- Too high an output capacitance or a ground fault in the floating network.

Troubleshooting

- Check the cables and the motor.

12.3.43 Fault Code 14, ID 138 - AC Drive Overtemperature (Fault)

Cause

- Output filter temperature is too high.

Troubleshooting

- Check the motor cables and the motor.
- Check the correct amount and flow of cooling air.
- Check the ambient temperature.

12.3.44 Fault Code 14, ID 139 - AC Drive Overtemperature (Fault)

Cause

- Brake chopper temperature is too high.

Troubleshooting

- Check the correct amount and flow of cooling air.
- Check the heat sink of the brake chopper for dust.
- Check the ambient temperature.

12.3.45 Fault Code 15, ID 140 - Motor Stall

Cause

- The motor stalled.

Troubleshooting

- Check the motor and the load.

12.3.46 Fault Code 16, ID 150 - Motor Overtemperature

Cause

- There is too heavy a load on the motor.

Troubleshooting

- Decrease the motor load. If there is no motor overload, check the motor thermal protection parameters (parameter group 3.9 Protections).

12.3.47 Fault Code 17, ID 160 - Motor Underload

Cause

- There is not a sufficient load on the motor.

Troubleshooting

- Check the load.
- Check the parameters.
- Check the dU/dt and sine wave filters.

12.3.48 Fault Code 18, ID 170 - Unbalance

Cause

- The current is unbalanced between power units.

Troubleshooting

- Check the motor cables and connections.
- Check the output filters (dU/dt filter, sine filter).
- Reset the fault and restart the drive.
- If the fault occurs again, ask for instructions from your nearest service center or distributor. Report carefully all the used software, application and options.

NOTICE

This fault is only used with enclosure sizes MR11 and MR12.

12.3.49 Fault Code 18, ID 171 - Unbalance**Cause**

- The DC voltage is unbalanced between power units.

Troubleshooting

- Check the DC link cables between the power units.
- Check the motor cables and connections.
- Check the output filters (dU/dt filter, sine filter).
- Reset the fault and restart the drive.
- If the fault occurs again, ask for instructions from your nearest service center or distributor. Report carefully all the used software, application, and options.

NOTICE

This fault is only used with enclosure sizes MR11 and MR12.

12.3.50 Fault Code 18, ID 173 - Unbalance (Alarm)**Cause**

- The current is unbalanced between power units.

Troubleshooting

- Check the installation and the motor cables.
- Redo the IGBT ID run.
- The event response can be set to No Action.

NOTICE

This fault is only used with enclosure sizes MR11 and MR12.

12.3.51 Fault Code 19, ID 180 - Power Overload (Short-time Supervision)**Cause**

- The power of the drive is too high.

Troubleshooting

- Decrease the load.
- Examine the dimensions of drive. Examine if it is too small for the load.

12.3.52 Fault Code 19, ID 181 - Power Overload (Long-time Supervision)**Cause**

- The power of the drive is too high.

Troubleshooting

- Decrease the load.
- Examine the dimensions of drive. Examine if it is too small for the load.

12.3.53 Fault Code 25, ID 240 - Motor Control Fault**Cause**

This fault is available only if you use a customer-specific application. A malfunction in the start angle identification.

- The rotor moves during identification.
- The new angle does not agree with the old value.

Troubleshooting

- Reset the fault and restart the drive.
- Increase the identification current.
- See the fault history source for more information.

12.3.54 Fault Code 25, ID 241 - Motor Control Fault

Cause

This fault is available only if you use a customer-specific application. A malfunction in the start angle identification.

- The rotor moves during identification.
- The new angle does not agree with the old value.

Troubleshooting

- Reset the fault and restart the drive.
- Increase the identification current.
- See the fault history source for more information.

12.3.55 Fault Code 26, ID 250 - Start-up Prevented

Cause

- It is not possible to do a start-up of the drive. When the Run request is ON, a new software (a firmware or an application), a parameter setting, or other file that affects the operation of the drive, is loaded to drive.

Troubleshooting

- Reset the fault and stop the drive.
- Load the software and start the drive.

12.3.56 Fault Code 29, ID 280 - ATEX Thermistor

Cause

- The ATEX thermistor tells that there is an overtemperature.

Troubleshooting

- Reset the fault. Check the thermistor and its connections.

12.3.57 Fault Code 30, ID 290 - Safe Off

Cause

- The safe Off signal A does not let you set the drive to the READY state.

Troubleshooting

- Reset the fault and restart the drive.
- Check the signals from the control board to the power unit and the D connector.

12.3.58 Fault Code 30, ID 291 - Safe Off

Cause

- The safe Off signal B does not let you set the drive to the READY state.

Troubleshooting

- Reset the fault and restart the drive.
- Check the signals from the control board to the power unit and the D connector.

12.3.59 Fault Code 30, ID 500 - Safety Configuration

Cause

- The safety configuration switch was installed.

Troubleshooting

- Remove the safety configuration switch from the control board.

12.3.60 Fault Code 30, ID 501 - Safety Configuration

Cause

- There are too many STO option boards. It is possible to have only 1.

Troubleshooting

- Keep 1 of the STO option boards. Remove the others. See the safety manual.

12.3.61 Fault Code 30, ID 502 - Safety Configuration

Cause

- The STO option board was installed in an incorrect slot.

Troubleshooting

- Put the STO option board into the correct slot. See the OPTBJ STO Safety manual.

12.3.62 Fault Code 30, ID 503 - Safety configuration

Cause

- There is no safety configuration switch on the control board.

Troubleshooting

- Install the safety configuration switch on the control board. See the safety manual.

12.3.63 Fault Code 30, ID 504 - Safety configuration

Cause

- The safety configuration switch was installed incorrectly on the control board.

Troubleshooting

- Install the safety configuration switch into the correct position on the control board. See the safety manual.

12.3.64 Fault Code 30, ID 505 - Safety configuration

Cause

- The safety configuration switch was installed incorrectly on the STO option board.

Troubleshooting

- Check the installation of the safety configuration switch on the STO option board. See the safety manual.

12.3.65 Fault Code 30, ID 506 - Safety configuration

Cause

- There is no communication with the STO option board.

Troubleshooting

- Check the installation of the STO option board. See the safety manual.

12.3.66 Fault Code 30, ID 507 - Safety configuration

Cause

- The STO option board is not compatible with the hardware.

Troubleshooting

- Reset the drive and restart it. If the fault occurs again, ask for instructions from your nearest distributor.

12.3.67 Fault Code 30, ID 520 - Safety diagnostics

Cause

- The STO inputs have a different status.

Troubleshooting

- Check the external safety switch. Check the input connection and cable of the safety switch.
- Reset the drive and restart.
- If the fault occurs again, ask for instructions from your nearest distributor.

12.3.68 Fault Code 30, ID 521 - Safety diagnostics

Cause

- A malfunction in the ATEX thermistor diagnostic. There is no connection in the ATEX thermistor input.

Troubleshooting

- Reset the drive and restart.
- If the fault occurs again, change the option board.

12.3.69 Fault Code 30, ID 522 - Safety diagnostics

Cause

- A short circuit in the connection of the ATEX thermistor input.

Troubleshooting

- Check the ATEX thermistor input connection.
- Check the external ATEX connection.
- Check the external ATEX thermistor.

12.3.70 Fault Code 30, ID 530 - Safe Torque Off

Cause

- An emergency stop was connected or some other STO operation was activated.

Troubleshooting

- When the STO function is activated, the drive is in safe state.

12.3.71 Fault Code 32, ID 311 - Fan Cooling

Cause

- The fan speed does not agree to the speed reference accurately, but the drive operates correctly.
- This fault shows only in the MR7 and in enclosure sizes bigger than MR7.

Troubleshooting

- Reset the fault and restart the drive.
- Clean or replace the fan.

12.3.72 Fault Code 32, ID 312 - Fan Cooling

Cause

- The fan life time (that is, 50 000 h) is complete.

Troubleshooting

- Replace the fan and reset the life time counter of the fan.

12.3.73 Fault Code 33, ID 320 - Fire Mode Enabled

Cause

- The fire mode of the drive is enabled. The protections of the drive are disabled or autoreset.

Troubleshooting

- Check the parameter settings and the signals.
- This alarm is reset automatically when fire mode is disabled.

12.3.74 Fault Code 37, ID 361 - Device Changed (Same Type)

Cause

- The power unit was replaced by a new one that has the same size. The device is ready to be used. The parameters are available in the drive.

Troubleshooting

- Reset the fault. The drive reboots after you reset the fault.

12.3.75 Fault Code 37, ID 362 - Device Changed (Same Type)

Cause

- The option board in slot B was replaced by a new one that you have used before in the same slot. The device is ready to be used.

Troubleshooting

- Reset the fault. The drive starts to use the old parameter settings.

12.3.76 Fault Code 37, ID 363 - Device Changed (Same Type)

Cause

- The option board in slot C was replaced by a new one that you have used before in the same slot. The device is ready to be used.

Troubleshooting

- Reset the fault. The drive starts to use the old parameter settings.

12.3.77 Fault Code 37, ID 364 - Device Changed (Same Type)

Cause

- The option board in slot D was replaced by a new one that you have used before in the same slot. The device is ready to be used.

Troubleshooting

- Reset the fault. The drive starts to use the old parameter settings.

12.3.78 Fault Code 37, ID 365 - Device Changed (Same Type)

Cause

- The option board in slot E was replaced by a new one that you have used before in the same slot. The device is ready to be used.

Troubleshooting

- Reset the fault. The drive starts to use the old parameter settings.

12.3.79 Fault Code 38, ID 372 - Device Added (Same Type)

Cause

- An option board was put into slot B. You have used the option board before in the same slot.

Troubleshooting

- The device is ready for use. The drive starts to use the old parameter settings.

12.3.80 Fault Code 38, ID 373 - Device Added (Same Type)

Cause

- An option board was put into slot C. You have used the option board before in the same slot.

Troubleshooting

- The device is ready for use. The drive starts to use the old parameter settings.

12.3.81 Fault Code 38, ID 374 - Device Added (Same Type)

Cause

- An option board was put into slot D. You have used the option board before in the same slot.

Troubleshooting

- The device is ready for use. The drive starts to use the old parameter settings.

12.3.82 Fault Code 38, ID 375 - Device Added (Same Type)

Cause

- An option board was put into slot E. You have used the option board before in the same slot.

Troubleshooting

- The device is ready for use. The drive starts to use the old parameter settings.

12.3.83 Fault Code 39, ID 382 - Device Removed

Cause

- An option board was removed from slot A or B.

Troubleshooting

- The device is not available. Reset the fault.

12.3.84 Fault Code 39, ID 383 - Device Removed

Cause

- An option board was removed from slot C.

Troubleshooting

- The device is not available. Reset the fault.

12.3.85 Fault Code 39, ID 384 - Device Removed

Cause

- An option board was removed from slot D.

Troubleshooting

- The device is not available. Reset the fault.

12.3.86 Fault Code 39, ID 385 - Device Removed

Cause

- An option board was removed from slot E.

Troubleshooting

- The device is not available. Reset the fault.

12.3.87 Fault Code 40, ID 390 - Device Unknown

Cause

- An unknown device was connected (the power unit/option board).

Troubleshooting

- The device is not available. If the fault occurs again, ask for instructions from your nearest distributor.

12.3.88 Fault Code 41, ID 400 - IGBT Temperature

Cause

The calculated IGBT temperature is too high.

- too high a motor load
- too high an ambient temperature
- hardware malfunction

Troubleshooting

- Check the parameter settings.
- Examine the actual amount and flow of cooling air.
- Check the ambient temperature.

- Examine the heatsink for dust.
- Make sure that the switching frequency is not too high in relation to the ambient temperature and the motor load.
- Check the cooling fan.
- Make an identification run.

12.3.89 Fault Code 44, ID 431 - Device Changed (Different Type)

Cause

- There is a new power unit of a different type. Parameters are not available in the settings.

Troubleshooting

- Reset the fault. The drive reboots after you reset the fault.
- Set the power unit parameters again.

12.3.90 Fault Code 44, ID 433 - Device Changed (Different Type)

Cause

- The option board in slot C was replaced by a new one that you have not used before in the same slot. No parameter settings are saved.

Troubleshooting

- Reset the fault. Set the option board parameters again.

12.3.91 Fault Code 44, ID 434 - Device Changed (Different Type)

Cause

- The option board in slot D was replaced by a new one that you have not used before in the same slot. No parameter settings are saved.

Troubleshooting

- Reset the fault. Set the option board parameters again.

12.3.92 Fault Code 44, ID 435 - Device Changed (Different Type)

Cause

- The option board in slot E was replaced by a new one that you have not used before in the same slot. No parameter settings are saved.

Troubleshooting

- Reset the fault. Set the option board parameters again.

12.3.93 Fault Code 45, ID 441 - Device Added (Different Type)

Cause

- There is a new power unit of a different type. Parameters are not available in the settings.

Troubleshooting

- Reset the fault. The drive reboots after you reset the fault.
- Set the power unit parameters again.

12.3.94 Fault Code 45, ID 443 - Device Added (Different Type)

Cause

- A new option board, that you have not used before in the same slot, was put in slot C. No parameter settings are saved.

Troubleshooting

- Set the option board parameters again.

12.3.95 Fault Code 45, ID 444 - Device Added (Different Type)

Cause

- A new option board, that you have not used before in the same slot, was put in slot D. No parameter settings are saved.

Troubleshooting

- Set the option board parameters again.

12.3.96 Fault Code 45, ID 445 - Device Added (Different Type)

Cause

- A new option board, that you have not used before in the same slot, was put in slot E. No parameter settings are saved.

Troubleshooting

- Set the option board parameters again.

12.3.97 Fault Code 46, ID 662 - Real Time Clock

Cause

- The voltage of the RTC battery is low.

Troubleshooting

- Replace the battery.

12.3.98 Fault Code 47, ID 663 - Software Updated

Cause

- The software of the drive was updated, the full software package or an application.

Troubleshooting

- No steps are necessary.

12.3.99 Fault Code 50, ID 1050 - AI Low Fault

Cause

- 1 or more of the available analog input signals is below 50% of the minimum signal range.
- A control cable is defective or loose.
- A malfunction in a signal source.

Troubleshooting

- Replace the defective parts.
- Check the analog input circuit.
- Make sure that parameter AI1 Signal Range is set correctly.

12.3.100 Fault Code 51, ID 1051 - Device External Fault

Cause

- The digital input signal that is set with parameter P3.5.1.11 or P3.5.1.12 was activated.

Troubleshooting

- This is a user-defined fault.
- Check the digital inputs and schematics.

12.3.101 Fault Code 52, ID 1052 - Keypad Communication Fault

Cause

- The connection between the control panel and the drive is defective.

Troubleshooting

- Check the control panel connection and the control panel cable if you have it.

12.3.102 Fault Code 52, ID 1352 - Keypad Communication Fault

Cause

- The connection between the control panel and the drive is defective.

Troubleshooting

- Check the control panel connection and the control panel cable if you have it.

12.3.103 Fault Code 53, ID 1053 - Fieldbus Communication Fault

Cause

- The data connection between the fieldbus master and the fieldbus board is defective.

Troubleshooting

- Check the installation and fieldbus master.

12.3.104 Fault Code 53, ID 1054 - Redundant Switchover

Cause

- The data connection between controlling fieldbus and the drive has timed out. Redundant control has changed the controlling fieldbus connection.

Troubleshooting

- Check the installation and the communication cables.

12.3.105 Fault Code 53, ID 1055 - Redundant Timeout

Cause

- The data connection between controlling fieldbus protocols and the drive has timed out.

Troubleshooting

- Check the installation and the communication cables.

12.3.106 Fault Code 54, ID 1354 - Slot A fault

Cause

- A defective option board or slot.

Troubleshooting

- Check the board and the slot.
- Ask for instructions from your nearest distributor.

12.3.107 Fault Code 54, ID 1454 - Slot B fault

Cause

- A defective option board or slot.

Troubleshooting

- Check the board and the slot.
- Ask for instructions from your nearest distributor.

12.3.108 Fault Code 54, ID 1554 - Slot C fault

Cause

- A defective option board or slot.

Troubleshooting

- Check the board and the slot.
- Ask for instructions from your nearest distributor.

12.3.109 Fault Code 54, ID 1654 - Slot D fault

Cause

- A defective option board or slot.

Troubleshooting

- Check the board and the slot.
- Ask for instructions from your nearest distributor.

12.3.110 Fault Code 54, ID 1754 - Slot E fault

Cause

- A defective option board or slot.

Troubleshooting

- Check the board and the slot.
- Ask for instructions from your nearest distributor.

12.3.111 Fault Code 57, ID 1057 - Identification

Cause

- There was a failure in the identification run.

Troubleshooting

- Make sure that the motor is connected to the drive.
- Make sure that there is no load on the motor shaft.
- Make sure that the start command is not removed before the identification run is complete.

12.3.112 Fault Code 57, ID 1157 - Identification

Cause

- During the identification run, drive was not able to reach required frequency reference.

Troubleshooting

- Make sure that minimum and maximum frequency references are set correctly. Too low maximum frequency can prevent drive from reaching required frequency.

12.3.113 Fault Code 57, ID 1257 - Identification

Cause

- During the identification run, drive was not able to reach required frequency reference.

Troubleshooting

- Make sure that acceleration time is set correctly. Too long acceleration time can prevent drive from reaching required frequency in 40 seconds.

12.3.114 Fault Code 57, ID 1357 - Identification

Cause

- During the identification run, drive was not able to reach required frequency reference.

Troubleshooting

- Make sure that current, torque, and power limits of the drive are set correctly. Too low limit settings can prevent drive from reaching required frequency.

12.3.115 Fault Code 63, ID 1063 - Quick Stop Fault

Cause

- The quick stop function is activated.

Troubleshooting

- Find the cause for the quick stop activation. After you find it, correct it. Reset the fault and restart the drive.
- See parameter P3.5.1.26 and the quick stop parameters.

12.3.116 Fault Code 63, ID 1363 - Quick Stop Alarm

Cause

- The quick stop function is activated.

Troubleshooting

- Find the cause for the quick stop activation. After you find it, correct it. Reset the fault and restart the drive.
- See parameter P3.5.1.26 and the quick stop parameters.

12.3.117 Fault Code 65, ID 1065 - PC Communication Fault

Cause

- The data connection between the PC and the drive is defective.

Troubleshooting

- Check the installation, cable, and terminals between the PC and the drive.

12.3.118 Fault Code 66, ID 1366 - Thermistor Input 1 Fault

Cause

- The motor temperature increased.

Troubleshooting

- Check the motor cooling and the load.
- Check the thermistor connection.
- If the thermistor input is not used, you have to short-circuit it.
- Ask for instructions from your nearest distributor.

12.3.119 Fault Code 66, ID 1466 - Thermistor Input 2 Fault

Cause

- The motor temperature increased.

Troubleshooting

- Check the motor cooling and the load.
- Check the thermistor connection.
- If the thermistor input is not used, you have to short-circuit it.
- Ask for instructions from your nearest distributor.

12.3.120 Fault Code 66, ID 1566 - Thermistor Input 3 Fault

Cause

- The motor temperature increased.

Troubleshooting

- Check the motor cooling and the load.
- Check the thermistor connection.
- If the thermistor input is not used, you have to short-circuit it.
- Ask for instructions from your nearest distributor.

12.3.121 Fault Code 68, ID 1301 - Maintenance Counter 1 Alarm

Cause

- The value of the maintenance counter is higher than the alarm limit.

Troubleshooting

- Do the necessary maintenance.
- Reset the counter. See parameter B3.16.4 or P3.5.1.40.

12.3.122 Fault Code 68, ID 1302 - Maintenance Counter 1 Fault

Cause

- The value of the maintenance counter is higher than the fault limit.

Troubleshooting

- Do the necessary maintenance.
- Reset the counter. See parameter B3.16.4 or P3.5.1.40.

12.3.123 Fault Code 68, ID 1303 - Maintenance Counter 2 Alarm

Cause

- The value of the maintenance counter is higher than the alarm limit.

Troubleshooting

- Do the necessary maintenance.
- Reset the counter. See parameter B3.16.4 or P3.5.1.40.

12.3.124 Fault Code 68, ID 1304 - Maintenance Counter 2 Fault

Cause

- The value of the maintenance counter is higher than the fault limit.

Troubleshooting

- Do the necessary maintenance.
- Reset the counter. See parameter B3.16.4 or P3.5.1.40.

12.3.125 Fault Code 69, ID 1310 - Fieldbus Mapping Error

Cause

- The ID number that is used to map the values to Fieldbus Process Data Out is not valid.

Troubleshooting

- Check the parameters in the Fieldbus Data menu.

12.3.126 Fault Code 69, ID 1311 - Fieldbus Mapping Error

Cause

- It is not possible to convert 1 or more values for Fieldbus Process Data Out.
- The type of the value is undefined.

Troubleshooting

- Check the parameters in the Fieldbus Data menu.

12.3.127 Fault Code 69, ID 1312 - Fieldbus Mapping Error

Cause

- There is an overflow when the values for Fieldbus Process Data Out (16-bit) are mapped and converted.

Troubleshooting

- Check the parameters in the Fieldbus Data menu.

12.3.128 Fault Code 70, ID 1120 - BaselineRun Failed

Cause

- There was a failure during the baseline run.

Troubleshooting

- Do a check of the parameters in the baseline run settings.

12.3.129 Fault Code 70, ID 1133 - Online Run Interrupted

Cause

- Online run interrupted before completion.

Troubleshooting

- Restart baseline run.

12.3.130 Fault Code 71, ID 1121 - Stator Winding: Current Warning S1

Cause

- Current unbalance has exceeded the detection high limit. Early fault detected in motor.

Troubleshooting

- Check motor stator windings.

12.3.131 Fault Code 71, ID 1122 - Stator Winding: Current Warning S2

Cause

- Current unbalance has exceeded the detection high limit. Severe fault can soon occur in the motor.

Troubleshooting

- Check motor stator windings.

12.3.132 Fault Code 71, ID 1123 - Stator Winding: Current Alarm/Fault

Cause

- Current unbalance has exceeded the detection high limit. Severe fault is detected in motor.

Troubleshooting

- Check motor stator windings.

12.3.133 Fault Code 71, ID 1127 - Vibration Warning S1

Cause

- Vibration has exceeded the detection high limit. Early fault detected in motor.

Troubleshooting

- Check root cause for increased vibration.

12.3.134 Fault Code 71, ID 1128 - Vibration Warning S2

Cause

- Vibration has exceeded the detection high limit. Severe fault can occur soon in the motor.

Troubleshooting

- Check root cause for increased vibration.

12.3.135 Fault Code 71, ID 1129 - Vibration Alarm/Fault

Cause

- Vibration has exceeded the detection high limit. Severe fault detected in motor.

Troubleshooting

- Check root cause for increased vibration.

12.3.136 Fault Code 71, ID 1130 - Load Warning S1

Cause

- Load outside of the window limits. Early fault detected in motor.

Troubleshooting

- Check root cause for excessive overload or underload.

12.3.137 Fault Code 71, ID 1131 - Load Warning S2

Cause

- Load outside of the window limits. Severe fault can occur soon in the motor.

Troubleshooting

- Check root cause for excessive overload or underload.

12.3.138 Fault Code 71, ID 1132 - Load Alarm/Fault

Cause

- Load outside of the window limits. Severe fault is detected in motor.

Troubleshooting

- Check root cause for excessive overload or underload.

12.3.139 Fault Code 71, ID 1134 - Zeros in baseline

Cause

- Zeros in baseline measurement data detected after baseline run completed.

Troubleshooting

- Check baseline data arrays and use modified point activation to correct data arrays or run new baseline.

12.3.140 Fault Code 76, ID 1076 - Start Prevented

Cause

- The start command is blocked to prevent the accidental rotation of the motor during the first power-up.

Troubleshooting

- Reset the drive to start the correct operation. The parameter settings tell if it is necessary to restart the drive.

12.3.141 Fault Code 77, ID 1077 - > 5 Connections

Cause

- There are more than 5 active fieldbus or PC tool connections. You can use only 5 connections at the same time.

Troubleshooting

- Leave 5 active connections. Remove the other connections.

12.3.142 Fault Code 78, ID 1078 - Identification Ongoing

Cause

- The drive is running the identification for the motor.

Troubleshooting

- You can stop the identification run at any time by removing the start command. When the identification run is completed, a new start command is needed to start the drive.

12.3.143 Fault Code 100, ID 1100 - Soft Fill Timeout

Cause

- There is a timeout in the Soft fill function in the PID controller. The process value was not achieved in the time limit.
- A pipe that broke can be the cause.

Troubleshooting

- Check the process.
- Check the parameters in the menu M3.13.8.

12.3.144 Fault Code 101, ID 1101 - Feedback Supervision Fault (PID 1)

Cause

- The feedback value is not in the supervision limits (P3.13.6.2 and P3.13.6.3) and the delay (P3.13.6.4), if you set the delay.

Troubleshooting

- Check the process.
- Check the parameter settings, the supervision limits, and the delay.

12.3.145 Fault Code 105, ID 1105 - Feedback Supervision Fault (ExtPID)

Cause

- The feedback value is not in the supervision limits (P3.14.4.2 and P3.14.4.3) and the delay (P3.14.4.4), if you set the delay.

Troubleshooting

- Check the process.
- Check the parameter settings, the supervision limits, and the delay.

12.3.146 Fault Code 109, ID 1109 - Input Pressure Supervision

Cause

- The supervision signal of the input pressure (P3.13.9.2) is lower than the alarm limit (P3.13.9.7).

Troubleshooting

- Check the process.
- Check the parameters in menu M3.13.9.
- Check the input pressure sensor and connections.

12.3.147 Fault Code 109, ID 1409 - Input Pressure Supervision

Cause

- The supervision signal of the input pressure (P3.13.9.2) is lower than the fault limit (P3.13.9.8).

Troubleshooting

- Check the process.
- Check the parameters in menu M3.13.9.
- Check the input pressure sensor and connections.

12.3.148 Fault Code 111, ID 1315 - Temperature Fault 1

Cause

- 1 or more of the temperature input signals (set in P3.9.6.1) is higher than the alarm limit (P3.9.6.2).

Troubleshooting

- Find the cause of the temperature rise.
- Check the temperature sensor and connections.
- If no sensor is connected, make sure that the temperature input is hardwired.
- See the option board manual for more data.

12.3.149 Fault Code 111, ID 1316 - Temperature Fault 1

Cause

- 1 or more of the temperature input signals (set in P3.9.6.1) is higher than the fault limit (P3.9.6.3).

Troubleshooting

- Find the cause of the temperature rise.
- Check the temperature sensor and connections.
- If no sensor is connected, make sure that the temperature input is hardwired.
- See the option board manual for more data.

12.3.150 Fault Code 112, ID 1317 - Temperature Fault 2

Cause

- 1 or more of the temperature input signals (set in P3.9.6.5) is higher than the fault limit (P3.9.6.6).

Troubleshooting

- Find the cause of the temperature rise.
- Check the temperature sensor and connections.
- If no sensor is connected, make sure that the temperature input is hardwired.
- See the option board manual for more data.

12.3.151 Fault Code 112, ID 1318 - Temperature Fault 2

Cause

- 1 or more of the temperature input signals (set in P3.9.6.5) is higher than the fault limit (P3.9.6.7).

Troubleshooting

- Find the cause of the temperature rise.
- Check the temperature sensor and connections.
- If no sensor is connected, make sure that the temperature input is hardwired.
- See the option board manual for more data.

12.3.152 Fault Code 113, ID 1113 - Pump Running Time

Cause

- In the Multi-pump system, 1 or more of the pump run-time counters is above a user-specified alarm limit.

Troubleshooting

- Do the necessary maintenance actions, reset the run-time counter, and reset the alarm. See Pump running time counters.

12.3.153 Fault Code 113, ID 1313 - Pump Running Time

Cause

- In the Multi-pump system, 1 or more of the pump run-time counters is above a user-specified alarm limit.

Troubleshooting

- Do the necessary maintenance actions, reset the run-time counter, and reset the alarm. See Pump running time counters.

12.3.154 Fault Code 117, ID 1117 - Flow Switch

Cause

- The feedback signal from the flow switch was inactive longer than the specified flow switch fault delay time.

Troubleshooting

- Do a check of the process.
- Do a check of the parameter settings.

12.3.155 Fault Code 118, ID 1118 - AHF Over Temp

Cause

- The advanced harmonic filter function has caused an overtemperature fault through a digital input.

Troubleshooting

- Check the advanced harmonic filter function.

12.3.156 Fault Code 119, ID 1119 - Auto Cleaning

Cause

- The motor did not reach the expected speed reference during the auto cleaning sequence.

Troubleshooting

- Check the process.
- Check the auto cleaning parameter settings.

12.3.157 Fault Code 300, ID 700 - Unsupported

Cause

- The application is not compatible (it is unsupported).

Troubleshooting

- Replace the application.

12.3.158 Fault Code 300, ID 701 - Unsupported

Cause

- The option board or the slot is not compatible (it is unsupported).

Troubleshooting

- Remove the option board.

12.4 Total and Trip Counters

The AC drive has different counters based on the operation time of the drive and the energy consumption. Some of the counters measure total values and some can be reset.

The energy counters measure the energy that is taken from the supply network. The other counters are used to measure, for example, the operation time of the drive or the run-time of the motor.

It is possible to monitor all the counter values from the PC, control panel, or fieldbus. When using the PC or the control panel, it is possible to monitor the counter values in the Diagnostics menu. When using fieldbus, it is possible to read the counter values with the ID numbers.

12.4.1 Operating Time Counter

Resetting: not possible

Location: submenu Total counters

The value of the counter has 5 different 16-bit values. To read the value of the counter through fieldbus, use these ID numbers.

ID number	Counter value
ID 1754	Operating Time Counter (years)
ID 1755	Operating Time Counter (days)
ID 1756	Operating Time Counter (hours)
ID 1757	Operating Time Counter (minutes)
ID 1758	Operating Time Counter (seconds)

Example

The value 1a 143d 02:21 is received from the operating time counter from the fieldbus.

- ID1754: 1 (years)
- ID1755: 143 (days)
- ID1756: 2 (hours)
- ID1757: 21 (minutes)
- ID1758: 0 (seconds)

12.4.2 Operating Time Trip Counter

The operating time trip counter of the control unit can be reset. It is in the submenu Trip counters. It is possible to reset the counter with the PC, the control panel, or the fieldbus. The value of the counter has 5 different 16-bit values. To read the value of the counter through fieldbus, use these ID numbers.

ID number	Counter value
ID 1766	Operating Time Trip Counter (years)
ID 1767	Operating Time Trip Counter (days)
ID 1768	Operating Time Trip Counter (hours)
ID 1769	Operating Time Trip Counter (minutes)
ID 1770	Operating Time Trip Counter (seconds)

Example

The value 1a 143d 02:21 is received from the operating time trip counter from the fieldbus.

- ID1766: 1 (years)
- ID1767: 143 (days)

- ID1768: 2 (hours)
- ID1769: 21 (minutes)
- ID1770: 0 (seconds)

ID number	Counter value
ID 2311	Operating Time Trip Counter Reset

To reset the energy trip counter, use the PC, the control panel, or the fieldbus. When using the PC or the control panel, reset the counter in the Diagnostics menu. When using the fieldbus, set a rising edge to ID 2311 Operating Time Trip Counter Reset.

12.4.3 Run Time Counter

The run time counter of the motor cannot be reset. It is in the submenu Total counters. The value of the counter has 5 different 16-bit values. To read the value of the counter through fieldbus, use these ID numbers.

ID number	Counter value
ID 1772	Run Time Counter (years)
ID 1773	Run Time Counter (days)
ID 1774	Run Time Counter (hours)
ID 1775	Run Time Counter (minutes)
ID 1776	Run Time Counter (seconds)

Example

The value 1a 143d 02:21 is received from the run time counter from the fieldbus.

- ID1772: 1 (years)
- ID1773: 143 (days)
- ID1774: 2 (hours)
- ID1775: 21 (minutes)
- ID1776: 0 (seconds)

12.4.4 Power on Time Counter

The power on time counter of the power unit is in the submenu Total counters. It is not possible to reset the counter. The value of the counter has 5 different 16-bit values. To read the value of the counter through fieldbus, use these ID numbers.

ID number	Counter value
ID 1777	Power On Time Counter (years)
ID 1778	Power On Time Counter (days)
ID 1779	Power On Time Counter (hours)
ID 1780	Power On Time Counter (minutes)
ID 1781	Power On Time Counter (seconds)

Example

The value 1a 240d 02:18 is received from the power on time counter from the fieldbus.

- ID1777: 1 (years)
- ID1778: 240 (days)
- ID1779: 2 (hours)

- ID1780: 18 (minutes)
- ID1781: 0 (seconds)

12.4.5 Energy Counter

The energy counter counts the total quantity of energy that the drive gets from the supply network. The counter cannot be reset. To read the value of the counter through fieldbus, use these ID numbers.

ID number	Counter value
ID 2291	Energy Counter

The value always has 4 digits. The format and the unit of the counter change to agree with the energy counter value.

Example

- 0.001 kWh
- 0.010 kWh
- 0.100 kWh
- 1.000 kWh
- 10.00 kWh
- 100.0 kWh
- 1.000 MWh
- 10.00 MWh
- 100.0 MWh
- 1.000 GWh
- and so on

ID number	Counter value
ID 2303	Energy Counter Format

The energy counter format gives the position of the decimal point in the value of the Energy Counter.

- 40 = 4 digits, 0 fractional digits
- 41 = 4 digits, 1 fractional digit
- 42 = 4 digits, 2 fractional digits
- 43 = 4 digits, 3 fractional digits

Example

- 0.001 kWh (Format = 43)
- 100.0 kWh (Format = 41)
- 10.00 MWh (Format = 42)

ID number	Counter value
ID 2305	Energy Counter Unit

The energy counter unit gives the unit for the value of the Energy Counter.

- 0 = kWh
- 1 = MWh
- 2 = GWh
- 3 = TWh
- 4 = PWh

Example

If the value 4500 is received from ID 2291, the value 42 from ID 2303, and the value 0 from ID 2305, the result is 45.00 kWh.

12.4.6 Energy Trip Counter

The energy trip counter counts the quantity of energy that the drive gets from the supply network. The counter is in the submenu Trip counters. It is possible to reset the counter with the PC, the control panel, or the fieldbus. To read the value of the counter through fieldbus, use these ID numbers.

ID number	Counter value
ID 2296	Energy Trip Counter

The value has always 4 digits. The format and the unit of the counter change to agree with the energy trip counter value. See the following example. It is possible to monitor the energy counter format and unit with ID 2307 Energy Trip Counter Format and ID 2309 Energy trip Counter unit.

Example

- 0.001 kWh
- 0.010 kWh
- 0.100 kWh
- 1.000 kWh
- 10.00 kWh
- 100.0 kWh
- 1.000 MWh
- 10.00 MWh
- 100.0 MWh
- 1.000 GWh
- and so on

ID number	Counter value
ID 2307	Energy Trip Counter Format

The energy trip counter format gives the position of the decimal point in the value of the Energy Trip Counter.

- 40 = 4 digits, 0 fractional digits
- 41 = 4 digits, 1 fractional digit
- 42 = 4 digits, 2 fractional digits
- 43 = 4 digits, 3 fractional digits

Example

- 0.001 kWh (Format = 43)
- 100.0 kWh (Format = 41)
- 10.00 MWh (Format = 42)

ID number	Counter value
ID 2309	Energy Trip Counter Unit

The energy trip counter unit gives the unit for the value of the Energy Trip Counter.

- 0 = kWh
- 1 = MWh
- 2 = GWh

- 3 = TWh
- 4 = PWh

ID number	Counter value
ID 2312	Energy Trip Counter Reset

To reset the energy trip counter, use the PC, the control panel, or the fieldbus. When using the PC or the control panel, reset the counter in the Diagnostics menu. When using the fieldbus, set a rising edge to ID 2312 Energy Trip Counter Reset.

Index

A		B	
Acc/Dec Prohibit (ID 415)	202	Back-up parameters	147
Acceleration Time 1 (ID 103)	190	Bandwidth (ID 1097)	264
Acceleration Time 2 (ID 502)	191	Bandwidth Delay (ID 1098)	265
Active Faults submenu	135	Baseline Data Element 1 (ID 3601)	163
Adding items in Favourites	148	Baseline Data Element 10 (ID 3610)	164
Additional resources	11	Baseline Data Element 2 (ID 3602)	163
Advanced Harmonic Filter	130	Baseline Data Element 3 (ID 3603)	163
AHF Over Temperature (ID 15513)	205, 205	Baseline Data Element 4 (ID 3604)	163
AI Low (ID 723)	230	Baseline Data Element 5 (ID 3605)	163
AI1 Custom. MAX (ID 381)	207	Baseline Data Element 6 (ID 3606)	163
AI1 Custom. MIN (ID 380)	207	Baseline Data Element 7 (ID 3607)	163
AI1 Signal Filter Time (ID 378)	205	Baseline Data Element 8 (ID 3608)	164
AI1 Signal Inversion (ID 387)	208	Baseline Data Element 9 (ID 3609)	164
AI1 Signal Range (ID 379)	206	Baseline Data Selector (ID 3509)	282
AI1 Signal Selection (ID 377)	205	Baseline Run Status (ID 3621)	164
Ambient Temperature (ID 705)	221	BaselineRun Duration (ID 3504)	282
Analog Input 1 (ID 59)	153	BaselineRun MaxFreq (ID 3503)	282
Analog Input 2 (ID 60)	154	BaselineRun MinFreq (ID 3502)	282
Analog Input 3 (ID 61)	154	BaselineRun Start (ID 3501)	281
Analog Input 4 (ID 62)	154	Basic I/O	140
Analog Input 5 (ID 75)	154	Basic monitoring	77
Analog Input 6 (ID 76)	154	Basic monitoring parameters	78
Analog Input Low Fault (ID 700)	229	Block Out.1 (ID 15020)	162
Analog Input Low Protection (ID 767)	228	Block Out.10 (ID 15200)	163
Anti-blocking Frequency (ID 1504)	278	Block Out.2 (ID 15040)	162
Anti-blocking Function	278	Block Out.3 (ID 15060)	162
Anti-blocking Interval (ID 1696)	278	Block Out.4 (ID 15080)	162
Anti-blocking Run-time (ID 1697)	278	Block Out.5 (ID 15100)	162
AO1 Filter Time (ID 10051)	214	Block Out.6 (ID 15120)	163
AO1 Function (ID 10050)	212	Block Out.7 (ID 15140)	163
AO1 Minimum (ID 10052)	214	Block Out.8 (ID 15160)	163
AO1 Minimum Scale (ID 10053)	214, 214	Block Out.9 (ID 15180)	163
Application (ID 212)	166	C	
Application settings	109	C/F Selection (ID 1197)	232
Application Status Word 1 (ID 89)	155	Changing control place	25
Application Status Word 2 (ID 90)	155	Changing items to monitor	75
Applications	29, 289	Changing rotation direction	21, 27
Assign to Channel (ID 1468)	236	Changing the access code	150
Assign to Channel (ID 1490)	236	Changing the control place	20
Auto-Cleaning	274	Channel 1 MAX (ID 2370)	166
Auto-Cleaning Activation (ID 1715)	204	Channel 1 MIN (ID 2369)	166
Autochange (ID 1027)	262	Channel 2 MAX (ID 2372)	166
Autochange (ID 1114)	158	Channel 2 MIN (ID 2371)	166
Autochange Days (ID 1786)	264	Clean Forward Frequency (ID 1717)	275, 275
Autochange Frequency Limit (ID 1031)	264	Clean Reverse Frequency (ID 1719)	275
Autochange Interval (ID 1029)	264	Clean Reverse Time (ID 1720)	275
Autochange Pump Limit (ID 1030)	264	Cleaning Acceleration Time (ID 1721)	275
Autochange Time of Day (ID 1787)	264	Cleaning Activation (ID 1715)	274
Autochanged Pumps (ID 1028)	262	Cleaning Current Delay (ID 1713)	275
Automatic reset	108	Cleaning Current Limit (ID 1712)	274
Automatic Reset (ID 731)	229	Cleaning Cycles (ID 1716)	275
Autoreset: EXT PID Supervision Fault (ID 777)	231	Cleaning Deceleration Time (ID 1722)	275
Autoreset: External Fault (ID 726)	231	Cleaning Function (ID 1714)	274
Autoreset: Motor Overtemperature (ID 725)	231	Cleaning Time of Day	275
Autoreset: PID Supervision Fault (ID 776)	231	Cleaning Weekdays (ID 1715)	275
Autoreset: Underload Fault (ID 738)	231	Communication Status (ID 1629)	159
Autoreset: Unit Overtemperature (ID 724)	231	Compare parameters	148
Autoscale (ID 2373)	167	Comparing parameters	23
		Condition-based Monitoring	85, 280, 281

Condition-based Monitoring Fault Mode (ID 3540).....	283
Condition-based Monitoring parameters.....	130
Condition-based Monitoring Status (ID 3619).....	165
Constant Production Speed (ID 1513).....	265
Control page.....	20, 26
Control places.....	19, 19
Control Signal 1 A (ID 403).....	200
Control Signal 1 B (ID 423).....	200
Control Signal 2 A (ID 404).....	200
Control Signal 2 B (ID 424).....	201
Control Signal 3 A (ID 434).....	200
Control Signal 3 B (ID 435).....	201
Copying the parameters.....	22
Counter 1 Alarm Limit (ID 1105).....	270
Counter 1 DI Reset (ID 490).....	270
Counter 1 Fault Limit (ID 1106).....	270
Counter 1 Mode (ID 1104).....	270
Counter 1 Reset (ID 1107).....	270
Counters.....	137
Current Alarm High Threshold (ID 3613).....	164
Current Alarm/Fault Counter (ID 3543).....	286
Current Alarm/Fault Delay (ID 3524).....	285
Current Alarm/Fault High (ID 3523).....	285
Current Alarm/Fault Mode (ID 3522).....	285
Current Interpolation Type (ID 3515).....	283
Current Max Factor (ID 3513).....	283
Current Mean Factor (ID 3511).....	283
Current Min Factor (ID 3512).....	283
Current Std Factor (ID 3514).....	283
Current Unbalance (ID 3617).....	164
Current Unbalance Threshold Value (ID 3620).....	164
Current Warning S1 Counter (ID 3541).....	286
Current Warning S1 Delay (ID 3518).....	285
Current Warning S1 High (ID 3517).....	285
Current Warning S1 High Threshold (ID 3611).....	164
Current Warning S1 Mode (ID 3516).....	284
Current Warning S2 Counter (ID 3542).....	286
Current Warning S2 Delay (ID 3521).....	285
Current Warning S2 High (ID 3520).....	285
Current Warning S2 High Threshold (ID 3612).....	164
Current Warning S2 Mode.....	285
D	
Days (ID 1466).....	236
DC Brake Current (ID 507).....	192
DC Braking Time at Stop (ID 508).....	192
DC Link Voltage (ID 7).....	151, 151
Dead Band (ID 1056).....	237
Dead Band Delay (ID 1057).....	237
Deceleration Time 1 (ID 104).....	190
Deceleration Time 2 (ID 503).....	191
Default Values of parameters.....	289
Delay (ID 737).....	244
Destaging Delay (ID 15589).....	269
Destaging Frequency (ID 15546).....	269
Digital Inputs.....	200
DIN Status Word 1 (ID 56).....	155
DIN Status Word 2 (ID 57).....	155
Drive customizer.....	127
Drive customizer monitoring.....	85
Drive info.....	139
Drive Status Word (ID 43).....	155
Duration (ID 1489).....	236
E	
Earth Fault (ID 703).....	220
Editing an interval.....	235
Editing numerical values.....	18, 25
Editing text values.....	18, 24
Enable External PID (ID 1630).....	252
Enable Feedback Supervision (ID 735).....	243
Enable Overpressure Supervision (ID 1698).....	266
Enable Setpoint 1 (ID 1189).....	245
Enable Supervision (ID 1685).....	248
Energy Counter.....	323
Energy Optimization (ID 666).....	170
Energy Trip Counter.....	324
Error Inversion (ID 340).....	237
External Fault Close (ID 405).....	201
External Fault Open (ID 406).....	201
External PID controller.....	120
External PID controller monitoring.....	82
External PID Setpoint Selection (ID 1048).....	203
External PID Start Signal (ID 1049).....	203
EXTPID Error (ID 85).....	158
EXTPID Feedback (ID 84).....	158
EXTPID Setpoint (ID 83).....	158
EXTPID Status (ID 86).....	158
EXTPID Status (ID 87).....	158
Extras and advanced.....	79
F	
Fault history.....	136, 136, 137
Fault Reset Close (ID 414).....	201
Fault Reset Open (ID 213).....	201
Fault Simulation (ID 1569).....	231
Fault tracing.....	295
Favourites menu.....	148
FB Control Word (ID 874).....	159
FB Data IN 1 (ID 876).....	160
FB Data IN 2 (ID 877).....	160
FB Data IN 3 (ID 878).....	160
FB Data IN 4 (ID 879).....	160
FB Data IN 5 (ID 880).....	161
FB Data IN 6 (ID 881).....	161
FB Data IN 7 (ID 882).....	161
FB Data IN 8 (ID 883).....	161
FB Data OUT 1 (ID 866).....	162
FB Data OUT 2 (ID 867).....	162
FB Data OUT 3 (ID 868).....	162
FB Data OUT 4 (ID 869).....	162
FB Data OUT 5 (ID 870).....	162
FB Data OUT 6 (ID 871).....	162
FB Data OUT 7 (ID 872).....	162
FB Data OUT 8 (ID 873).....	162
FB DataOut 1 Selection (ID 852).....	215
FB DataOut 10 Selection (ID 891).....	216
FB DataOut 11 Selection (ID 892).....	216
FB DataOut 12 Selection (ID 893).....	216
FB DataOut 13 Selection (ID 894).....	216
FB DataOut 14 Selection (ID 895).....	216
FB DataOut 15 Selection (ID 896).....	216
FB DataOut 16 Selection (ID 897).....	216
FB DataOut 2 Selection (ID 853).....	215
FB DataOut 3 Selection (ID 854).....	215
FB DataOut 4 Selection (ID 855).....	215

FB DataOut 5 Selection (ID 856).....	215	Frost Temperature Monitoring (ID 1711).....	279
FB DataOut 6 Selection (ID 857).....	215	FUNCT button.....	19, 25
FB DataOut 7 Selection (ID 858).....	215	FUNCT Button Configuration (ID 1195).....	232
FB DataOut 8 Selection (ID 859).....	215	Functions.....	12
FB DataOut 9 Selection (ID 890).....	216		
FB Speed Actual (ID 865).....	161	H	
FB Speed Reference (ID 875).....	160	HVAC application.....	29
FB Status Word (ID 864).....	161	HVAC application wizard.....	68
Feedback 1 Maximum (ID 337).....	239		
Feedback 1 Minimum (ID 336).....	239	I	
Feedback 1 Source Selection (ID 334).....	239	I/f Start (ID 534).....	175
Feedback Function (ID 333).....	239	I/f Start Frequency (ID 535).....	175
Feedback Function Gain (ID 1058).....	239	I/f Start Frequency (ID 536).....	175
Feedback Sensor Connection in a Multi-pump System.....	259	I/f Start Function.....	174
Feedback Supervision.....	243	I/O A Start/Stop Logic (ID 300).....	177
Feedforward 1 Maximum (ID 1063).....	240	I/O B Control Force (ID 425).....	201
Feedforward 1 Minimum (ID 1062).....	240	I/O B Reference Force (ID 343).....	201
Feedforward 1 Source Selection (ID 1061).....	240	I/O B Start/Stop Logic (ID 363).....	183
Feedforward Function (ID 1059).....	239	I/O configuration.....	95
Feedforward Gain (ID 1060).....	240	I/O Control Reference A Selection (ID 117).....	185
Field Weakening Point Frequency (ID 602).....	173	I/O Control Reference B Selection (ID 131).....	185
Fieldbus.....	143	I/O monitoring.....	78
Fieldbus Communication Fault Clear Delay (ID 752).....	221	Identification (ID 631).....	168
Fieldbus Communication Fault Force Delay (ID 751).....	221	Input Phase Fault (ID 730).....	219, 220
Fieldbus Control Force (ID 411).....	201	Input Pressure Supervision.....	247
Fieldbus data.....	102	Interlocks.....	259
Fieldbus general.....	145, 145	Interval 2 (ID 1443).....	156
Fieldbus process data monitoring.....	83	Interval 3 (ID 1444).....	156
Fieldbus redundancy.....	146	Interval 4 (ID 1445).....	156
Fieldbus Sign of Actual (ID 888).....	216	Interval 5 (ID 1446).....	157
Fieldbus Start Logic (ID 889).....	183	Intervals).....	233
Fire mode.....	126		
Fire Mode Activation Close (ID 1619).....	203	J	
Fire Mode Activation on Close (ID 1619).....	272	Jockey Function (ID 1674).....	276
Fire Mode Activation on Open (ID 1596).....	271	Jockey Start Level (ID 1675).....	277
Fire Mode Activation Open (ID 1596).....	203	Jockey Stop Level (ID 1676).....	277
Fire Mode Counter (ID 1679).....	272		
Fire Mode Frequency (ID 1598).....	271	K	
Fire Mode Frequency Source (ID 1617).....	271	Keypad.....	142
Fire Mode Function.....	270	Keypad Control Force (ID 410).....	201
Fire Mode Password (ID 1599).....	271	Keypad Control Reference Selection (ID 121).....	185
Fire Mode Reverse (ID 1618).....	204, 272, 272	Keypad Direction (ID 123).....	185
Fire Mode Run Indication Current (ID 15580).....	272	Keypad Reference (ID 184).....	185
Fire Mode wizard.....	73	Keypad Setpoint 1 (ID 167).....	238
Flow Switch (ID 15590).....	205, 279	Keypad Setpoint 2 (ID 168).....	238
Flow Switch Bypass at Start (ID 15586).....	279	Keypad Stop Button (ID 114).....	177
Flow Switch Fault Delay (ID 15585).....	279	kW/HP Selection (ID 1198).....	232
Flow Switch Minimum Frequency (ID 15587).....	279	kWh Trip Counter High (ID 1067).....	153
Flushing Parameters.....	189	kWh Trip Counter Low (ID 1054).....	153
Flushing Reference (ID 1239).....	189		
Flushing Reference Activation (ID 530).....	189, 203	L	
Flux Braking (ID 520).....	192	Last Active Alarm Code (ID 74).....	156
Flux Braking Current (ID 519).....	193	Last Active Alarm ID (ID 77).....	156
Flying Start Options (ID 1590).....	174	Last Active Alarm ID (ID 94).....	156
Flying Start Scan Current (ID 1610).....	174	Last Active Fault Code (ID 37).....	156
Frequency Reference.....	184	Last Active Fault ID (ID 95).....	156
Frequency Reference (ID 25).....	151, 151	License parameters.....	148
Frequency Reference Source (ID 1495).....	156	Line Freq (ID 1913).....	283
Frequency to Start DC Braking at Ramp Stop (ID 515).....	192	Line Freq Hysteresis (ID 1914).....	283
Frost Protection.....	278	Load Alarm High Threshold (ID 3631).....	165
Frost Protection (ID 1704).....	279	Load Alarm Low Threshold (ID 3634).....	165
Frost Protection Frequency (ID 1710).....	279		
Frost Protection Temperature Limit (ID 1708).....	279		

Load Alarm/Fault Counter (ID 3583).....	289	Motor Preheat Function (ID 1225).....	273
Load Alarm/Fault Delay (ID 3580).....	288	Motor Preheat ON (ID 1044).....	273
Load Alarm/Fault High (ID 3579).....	288	Motor preheat parameters.....	127
Load Alarm/Fault Low (ID 3586).....	289	Motor Settings.....	88
Load Alarm/Fault Mode (ID 3578).....	288	Motor shaft power (ID 73).....	152
Load Interpolation Type (ID 3571).....	284	Motor Shaft Power 1 Decimal (ID 98).....	156
Load Max Factor (ID 3569).....	284	Motor Speed (ID 2).....	151, 151
Load Mean Factor (ID 3567).....	284	Motor Stall Fault (ID 709).....	224
Load Min Factor (ID 3568).....	284	Motor Stall Protection.....	224
Load S1 High Threshold (ID 3629).....	165	Motor Switch (ID 653).....	168
Load S1 Low Threshold (ID 3632).....	165	Motor Temperature (ID 9).....	153
Load S2 High Threshold (ID 3630).....	165	Motor Thermal Loadability (ID 708).....	223
Load S2 Low Threshold (ID 3633).....	165	Motor Thermal Protection (ID 704).....	221
Load Std Factor (ID 3570).....	284	Motor Thermal Protections.....	221
Load Threshold Value (ID 3628).....	165	Motor Thermal Time Constant (ID 707).....	222
Load Warning S1 Counter (ID 3581).....	289	Motor Torque (ID 4).....	151, 151
Load Warning S1 Delay (ID 3574).....	288	Motor Torque Limit (ID 1287).....	171
Load Warning S1 High (ID 3573).....	288	Motor Type (ID 650).....	167
Load Warning S1 Low (ID 3584).....	289	Motor Voltage (ID 6).....	152, 152
Load Warning S1 Mode (ID 3572).....	287	Motors Running (ID 30).....	158
Load Warning S2 Counter (ID 3582).....	289	Multi-pump.....	123
Load Warning S2 Delay (ID 3577).....	288	Multi-pump (multidrive) application.....	44
Load Warning S2 High (ID 3576).....	288	Multi-pump (multidrive) wizard.....	72
Load Warning S2 Low (ID 3585).....	289	Multi-pump (single drive) application.....	37
Load Warning S2 Mode (ID 3575).....	288	Multi-pump (single drive) wizard.....	70
Local/Remote (ID 211).....	176	Multi-pump function.....	253
Lower Limit (ID 758).....	244	Multi-pump Mode (ID 1785).....	256
M			
Magnetizing Current (ID 612).....	168	Multi-pump monitoring.....	82
Maintenance Counter 1 (ID 1101).....	159	Multi-pump Status (ID 1628).....	158
Maintenance counters.....	125	Multi-setpoint 0 (ID 15560).....	251
Maintenance Counters.....	269	Multi-setpoint 1 (ID 15561).....	251
Manual Run.....	282	Multi-setpoint 10 (ID 15570).....	252
Maximum Frequency Reference (ID 102).....	184	Multi-setpoint 11 (ID 15571).....	252
Menu structure.....	15	Multi-setpoint 12 (ID 15572).....	252
Minimum Frequency Reference (ID 101).....	184	Multi-setpoint 13 (ID 15573).....	252
Modified Activation (ID 3505).....	282	Multi-setpoint 14 (ID 15574).....	252
Modified Array (ID 3506).....	282	Multi-setpoint 15 (ID 15575).....	252
Modified Point (ID 3507).....	282	Multi-setpoint 2 (ID 15562).....	251
Modified Value (ID 3508).....	282	Multi-setpoint 3 (ID 15563).....	251
Monitor menu.....	75	Multi-setpoint 4 (ID 15564).....	251
Monitoring of maintenance counters.....	83	Multi-setpoint 5 (ID 15565).....	251
Motor BEM Voltage (ID 674).....	171	Multi-setpoint 6 (ID 15566).....	251
Motor Cos Phi (ID 120).....	167	Multi-setpoint 7 (ID 15567).....	251
Motor Current (ID 3).....	151, 151	Multi-setpoint 9 (ID 15569).....	251
Motor Current 1 Deci (ID 45).....	155	Multi-setpoint Selection 0 (ID 15576).....	205, 252
Motor Current Limit (ID 107).....	171	Multi-setpoint Selection 1 (ID 15577).....	205, 252
Motor Nominal Current (ID 113).....	167	Multi-setpoint Selection 2 (ID 15578).....	205, 252
Motor Nominal Frequency (ID 111).....	167	Multi-setpoint Selection 3 (ID 15579).....	205, 252
Motor Nominal Power (ID 116).....	167	Multimonitor View (ID 1196).....	232
Motor Nominal Speed (ID 112).....	167	N	
Motor Nominal Voltage (ID 110).....	167	Negative Frequency Reference Limit (ID 1286).....	184
Motor Potentiometer DOWN (ID 417).....	188	Next Autochange (ID 1503).....	158
Motor Potentiometer Down (ID 417).....	202, 202	no term text found	
Motor Potentiometer Parameters.....	188	Number of Pumps (ID 1001).....	258
Motor Potentiometer Ramp Time (ID 331).....	188	Number of Trials (ID 759).....	230
Motor Potentiometer Reset (ID 367).....	189	O	
Motor Potentiometer UP (ID 418).....	188	OFF Time (ID 1465).....	235
Motor Potentiometer Up (ID 418).....	202	ON Time (ID 1464).....	235
Motor Power (ID 5).....	151, 151	Operate Mode (ID 1505).....	158
Motor preheat (ID 1228).....	153	Operating Time Counter.....	321
Motor Preheat Current (ID 1227).....	273		

Operating Time Trip Counter.....	321	Prohibit Frequencies Function.....	217
Operation Mode (ID 15001).....	274	Prohibit Frequency Range 1 High Limit (ID 510).....	217
Option board slots.....	140	Prohibit Frequency Range 1 High Limit (ID 511).....	217
Output Frequency (ID 1).....	151, 151	Prohibit Frequency Range 1 Low Limit (ID 509).....	217
Overcurrent (ID 722).....	230	Prohibit Frequency Range 2 High Limit (ID 512).....	217
Overpressure Supervision.....	266	Prohibit Frequency Range 3 High Limit (ID 514).....	217
Overvoltage (ID 721).....	230	Prohibit Frequency Range 3 Low Limit (ID 513).....	217
Overvoltage Control (ID 607).....	169	Protections.....	105
P		Pump (1) Running Time (ID 1620).....	159
Parameter Lock Key (ID 1808).....	232	Pump (2) Running Time (ID 1621).....	159
Parameter Set 1/2 Selection (ID 496).....	205	Pump (3) Running Time (ID 1622).....	159
Password (ID 1806).....	232	Pump (4) Running Time (ID 1623).....	159
PID Control application.....	33	Pump (5) Running Time (ID 1624).....	159
PID Control application wizard.....	69	Pump (6) Running Time (ID 1625).....	159
PID controller.....	112	Pump (7) Running Time (ID 1626).....	159
PID controller monitoring.....	81	Pump (8) Running Time (ID 1627).....	159
PID Derivation Time (ID 132).....	236	Pump 1 Interlock (ID 426).....	204, 265
PID Error (ID 22).....	157	Pump 2 Interlock (ID 427).....	204, 266
PID Feedback (1) (ID 15541).....	157	Pump 3 Interlock (ID 428).....	204, 266
PID Feedback (2) (ID 15542).....	157	Pump 4 Interlock (ID 429).....	204, 266
PID Feedback (ID 21).....	157	Pump 5 Interlock (ID 430).....	204, 266
PID Gain (ID 118).....	236	Pump 6 Interlock (ID 486).....	204, 266
PID Integration Time (ID 119).....	236	Pump 7 Interlock (ID 487).....	204, 266
PID Output (ID 23).....	157	Pump 8 Interlock (ID 488).....	204, 266
PID Setpoint (ID 20).....	157	Pump control.....	127
PID Setpoint Boost (ID 1046).....	203	Pump ID Number (ID 1500).....	258
PID Setpoint Boost Activation (ID 1046).....	238	Pump Interlocking (ID 1032).....	259
PID Setpoint Reduction (ID 1694).....	249	Pump Run-time Alarm Limit (ID 1109).....	268
PID Setpoint Selection (ID 1047).....	203, 238	Pump Run-time Counters.....	267
PID Soft Fill Fault (ID 748).....	220	Pump Run-time Fault Limit (ID 1110).....	268
PID Status (ID 24).....	158	Q	
Positive Frequency Reference Limit (ID 1285).....	184	Qualified personnel.....	11
Power on Time Counter.....	322	Quick Stop Deceleration Time (ID 1256).....	227
Power unit settings.....	142	Quick Stop Mode (ID 1276).....	227, 227
Preheat Motor Temperature (ID 1045).....	273	R	
Preheat Temperature Limit (ID 1226).....	273	Ramp 1 Shape (ID 500).....	189
Preset Alarm Frequency (ID 183).....	220	Ramp 2 Selection (ID 408).....	191, 202
Preset Frequencies.....	185	Ramp 2 Shape (ID 501).....	190
Preset Frequency 0 (ID 180).....	186	Ramp 2 Threshold Frequency (ID 533).....	191
Preset Frequency 1 (ID 105).....	186	Ramps and brakes setup.....	94
Preset Frequency 2 (ID 106).....	187	Reading help texts.....	24
Preset Frequency 3 (ID 126).....	187	Ready Status (ID 78).....	155
Preset Frequency 4 (ID 127).....	187	Real-time clock.....	141
Preset Frequency 5 (ID 128).....	187	Real-time Clock (ID 1450).....	157
Preset Frequency 6 (ID 129).....	187	References.....	91
Preset Frequency 7 (ID 130).....	187	Remote Control Place (ID 172).....	176
Preset Frequency Mode (ID 182).....	185	Remote to Local Function (ID 181).....	184
Preset Frequency Selection 0 (ID 419).....	187, 202	Removing items from Favourites.....	148
Preset Frequency Selection 1 (ID 420).....	187, 202, 202	Reset faults.....	135, 135, 135, 135
Preset Frequency Selection 2 (ID 421).....	187	Reset kWh Trip Counter (ID 1053).....	205
Pressure Loss Compensation.....	245	Reset Maintenance Counter (ID 490).....	203
Priming Function (ID 1677).....	278, 278	Resetting a fault.....	19, 19
Priming Pump.....	277	Response to External Fault (ID 701).....	219
Process Unit Decimals (ID 1035).....	237	Response to External PID Supervision Fault (ID 757).....	220
Process Unit MAX (ID 1034).....	237	Response to Fieldbus Communication Fault (ID 733).....	220
Process Unit Selection (ID 1036).....	236, 236	Response to Output Phase Fault (ID 702).....	220
Programmable Inputs		Response to PID Supervision Fault (ID 749).....	220, 245
Default functions.....	200	Response to Quick Stop Fault (ID 744).....	227
Programming of Analog Inputs.....	197, 199, 199	Response to Safe Torque Off (STO) Fault (ID 775).....	221
Programming of Digital Inputs.....	194, 196, 196	Restart Delay (ID 15555).....	184
Programming of inputs.....	193		
Prohibit frequencies.....	104		

Restart Function (ID 719).....	229	Start Boost (ID 109).....	174
RO1 Function (ID 11001).....	209, 212	Start Delay (ID 524).....	184
RO1 OFF Delay (ID 11003).....	212	Start Function (ID 505).....	177
Run Enable (ID 407).....	201	Start Magnetizing Current (ID 517).....	192
Run Interlock 1 (ID 1041).....	201	Start Magnetizing Time (ID 516).....	192
Run Interlock 2 (ID 1042).....	202, 202	Start Signal (ID 1049).....	253
Run Time Counter.....	322	Start-up quick guide.....	13
Running Pumps Limit (ID 1187).....	265	Start-up wizard.....	13
S		Start/Stop setup.....	90
Sampling Interval (ID 2368).....	166	Stator Inductance Voltage Drop (ID 673).....	171
Selecting more than 1 value.....	19	Stator Resistance Voltage Drop (ID 662).....	171
Set Parameter Lock (ID 1807).....	232	Stator Voltage Adjust (ID 659).....	170
Set Run-time Counter (ID 1673).....	267	Stator Winding Monitoring.....	283
Set Run-time Counter: Pump Selection (ID 1088).....	268	STO.....	146
Set Run-time Counter: Value (ID 1087).....	267	Stop Counter Delay (ID 3549).....	286, 286
Setpoint 1 Boost (ID 1071).....	238	Stop Function (ID 506).....	177
Setpoint 1 Maximum (ID 1070).....	238	Supervision #1 Item Selection (ID 1431).....	219
Setpoint 1 Minimum (ID 1069).....	238	Supervision #1 Limit (ID 1433).....	219
Setpoint Ramp Time (ID 1068).....	238	Supervision #1 Limit Hysteresis (ID 1434).....	219
Setpoint Reduction Interpolation Source (ID 1407).....	249	Supervision #1 Mode (ID 1432).....	219
Setpoint Source 1 Selection (ID 332).....	238	Supervision #2 Item Selection (ID 1435).....	219
Signal Sources.....	199	Supervision #2 Limit (ID 1437).....	219
Simple Network Time Protocol.....	141	Supervision #2 Limit Hysteresis (ID 1438).....	219
Sleep Function When No Demand Is Detected.....	250	Supervision #2 Mode (ID 1436).....	219
Sleep No Demand Detection Enable (ID 1649).....	250	Supervision Alarm Level (ID 1691).....	249
Slot Communication Fault (ID 734).....	220	Supervision Alarm Level (ID 1699).....	267
SlotA AO1 (ID 81).....	154	Supervision Fault Delay (ID 1693).....	249
SlotA DIN 1,2,3 (ID 15).....	153	Supervision Fault Level (ID 1692).....	249
SlotA DIN 4,5,6 (ID 16).....	153	Supervision Signal (ID 1686).....	248
SlotB RO 1,2,3 (ID 17).....	153	Supervision Unit Decimals (ID 1688).....	249
SNDD Error Hysteresis (ID 1658).....	250	Supervision Unit Maximum Value (ID 1690).....	249
SNDD Frequency Hysteresis (ID 1663).....	250	Supervision Unit Minimum Value (ID 1689).....	249
SNDD Supervision Time (ID 1668).....	250	Supervision Unit Selection (ID 1687).....	249
SNND Actual Add (ID 1669).....	251	Supervisions.....	104
Soft Fill.....	246	Switching Frequency (ID 601).....	168
Soft Fill Fault (ID 748).....	247	T	
Soft Fill Frequency (ID 1055).....	247	TC 1, TC 2, TC 3 (ID 1441).....	156
Soft Fill Function (ID 1094).....	246	TC 1, TC 2, TC 3 (ID 1442).....	156
Soft Fill Level (ID 1095).....	247	Temperature input (ID 71).....	155
Soft Fill Timeout (ID 1096).....	247	Temperature input 1 (ID 50).....	154
Software info.....	139	Temperature input 2 (ID 51).....	154
SP1 Sleep Boost (ID 1793).....	242	Temperature input 3 (ID 52).....	154
SP1 Sleep Boost Maximum Time (ID 1795).....	242	Temperature input 4 (ID 69).....	154
SP1 Sleep Delay (ID 1017).....	241	Temperature input 5 (ID 70).....	154
SP1 Sleep Frequency (ID 1016).....	240	Temperature inputs.....	79, 154
SP1 Wake-Up Level (ID 1018).....	241	Temperature Signal (ID 1705).....	279
SP1 Wake-Up Mode (ID 1019).....	241	Temperature Signal Maximum (ID 1707).....	279
SP2 Sleep Boost (ID 1794).....	243	Temperature Signal Minimum (ID 1706).....	279
SP2 Sleep Boost Maximum Time (ID 1796).....	243	Thermistor Fault (ID 732).....	220
SP2 Sleep Delay (ID 1076).....	242	Threshold Value.....	283
SP2 Sleep Frequency (ID 1075).....	242	Time channels.....	233
SP2 Wake-Up Level (ID 1077).....	242	Timer 1 (ID 1447).....	157
SP2 Wake-Up Mode (ID 1020).....	242	Timer 1 (ID 447).....	202, 236
Staging Delay (ID 15588).....	269	Timer 2 (ID 1448).....	157
Staging Frequency (ID 15545).....	268	Timer 2 (ID 448).....	203
Stall Current (ID 710).....	225	Timer 3 (ID 1449).....	157
Stall Frequency Limit (ID 712).....	225	Timer 3 (ID 449).....	203
Stall Time Limit (ID 711).....	225	Timer functions.....	110
Standard application.....	29	Timer Functions.....	232
Standard application wizard.....	68	Timer functions monitoring.....	81
Start and Feedback Signals (ID 1782).....	258	Timers.....	233
Start and Stop Commands.....	176	Torque Stabilator Damping Time Constant (ID 1413).....	176

Torque Stabilator Damping Time Constant for PM Motors (ID 1735).....	176	Vibration (ID 3623).....	164
Torque Stabilator Filter Time Constant (ID 15650).....	176	Vibration Alarm High Threshold (ID 3627).....	165
Torque Stabilator Filter Time Constant for PM Motors (ID 15651).....	176	Vibration Alarm/Fault Counter (ID 3566).....	287
Torque Stabilator Gain (ID 1412).....	175	Vibration Alarm/Fault Delay (ID 3563).....	287
Torque Stabilator Gain at Field Weakening Point (ID 1414).....	175	Vibration Alarm/Fault High (ID 3562).....	287
Total and Trip Counters.....	321	Vibration Alarm/Fault Mode (ID 3561).....	287
Total counters.....	137	Vibration Input (ID 3587).....	289
Trend curve.....	75, 75, 76	Vibration Interpolation Type (ID 3554).....	284
Trend curve parameters.....	77	Vibration Max Factor (ID 3552).....	284
Trial Time (ID 718).....	230	Vibration Mean Factor (ID 3550).....	283
Trip counters.....	138	Vibration Min Factor (ID 3551).....	284
		Vibration S1 High Threshold (ID 3625).....	164
U		Vibration S2 High Threshold (ID 3626).....	165
U/f Midpoint Voltage (ID 605).....	174	Vibration Std Factor (ID 3553).....	284
U/F Ratio (ID 108).....	171	Vibration Threshold Value (ID 3624).....	164
Unbalance Current Alarm (ID 753).....	221	Vibration Warning S1 Counter (ID 3564).....	287
Underload (Dry Pump) Protection.....	225	Vibration Warning S1 Delay (ID 3557).....	286
Underload Fault (ID 713).....	225	Vibration Warning S1 High (ID 3556).....	286
Underload Protection: Field Weakening Area Load (ID 714).....	226	Vibration Warning S1 Mode (ID 3555).....	286
Underload Protection: Time Limit (ID 716).....	226	Vibration Warning S2 Counter (ID 3565).....	287
Underload Protection: Zero Frequency Load (ID 715).....	226	Vibration Warning S2 Delay (ID 3560).....	287
Undervoltage (ID 720).....	230	Vibration Warning S2 High (ID 3559).....	286
Undervoltage Control (ID 608).....	169	Vibration Warning S2 Mode (ID 3558).....	286
Unit status.....	139	Voltage at Field Weakening Point (ID 603).....	173, 173
Unit Temperature (ID 8).....	151, 151		
Upper Limit (ID 736).....	244	W	
User level menu.....	149	Wait Time (ID 717).....	229
User level parameters.....	149	Warning and Alarm/Fault Stages.....	284
User settings.....	147	Wizards in Menu 1.1.....	73
Using Quick Edit function.....	22, 22		
Using the Favourites menu.....	24	Z	
		Zero Frequency Voltage (ID 606).....	174
V		Zero Speed Cooling Factor (ID 706).....	222
VACON® Live.....	27		

ENGINEERING
TOMORROW

Danfoss

**Vacon Ltd, Member of the
Danfoss Group**
Runsorintie 7
FIN-65380 Vaasa
www.danfoss.com

Danfoss can accept no responsibility for possible errors in catalogs, brochures and other printed material. Danfoss reserves the right to alter its products without notice. This also applies to products already on order provided that such alterations can be made without subsequential changes being necessary in specifications already agreed. All trademarks in this material are property of the respective companies. Danfoss and the Danfoss logotype are trademarks of Danfoss A/S. All rights reserved.

