

MAKING MODERN LIVING POSSIBLE



Programming Guide

VLT[®] DriveMotor FCP 106/FCM 106



Contents

1 Introduction	5
1.1 Purpose of the Manual	5
1.2 Additional Resources	5
1.3 Document and Software Version	5
1.4 Symbols, Abbreviations, and Definitions	5
1.5 Electrical Overview	7
2 Programming	8
2.1 Programming with MCT 10 Set-up Software	8
2.2 Graphical Local Control Panel (GLCP)	8
2.3 GLCP Menus	9
2.3.1 Status Menu	9
2.3.2 Quick Menu	9
2.3.3 Main Menu	9
2.3.4 Configuration for Open-loop Applications	9
2.3.5 Set-up Wizard for Closed-loop Applications	11
2.3.6 Quick Menu Motor Set-up	12
2.4 Programming Parameters	13
2.5 Back-up and Copying Parameter Settings	13
2.6 Restoring Default Settings	13
3 RS485 Installation and Set-up	15
3.1 RS485	15
3.1.1 Overview	15
3.1.2 EMC Precautions	16
3.1.3 Network Connection	16
3.1.4 Parameter Settings for Modbus Communication	17
3.2 FC Protocol	17
3.3 Network Configuration	18
3.4 FC Protocol Message Framing Structure	18
3.4.2 Telegram Structure	19
3.4.4 Frequency Converter Address (ADR)	19
3.4.5 Data Control Byte (BCC)	19
3.4.6 The Data Field	20
3.4.7 The PKE Field	21
3.4.8 Parameter Number (PNU)	21
3.4.9 Index (IND)	21
3.4.10 Parameter Value (PWE)	21
3.4.11 Data Types Supported by the Frequency Converter	22
3.4.12 Conversion	22

3.5 Examples	22
3.6 Modbus RTU Overview	23
3.6.1 Prerequisite Knowledge	23
3.6.2 What the User Should Already Know	23
3.6.3 Overview	23
3.6.4 Frequency Converter with Modbus RTU	24
3.7 Network Configuration	24
3.8 Modbus RTU Message Framing Structure	24
3.8.1 Introduction	24
3.8.2 Modbus RTU Message Structure	24
3.8.3 Start/Stop Field	25
3.8.4 Address Field	25
3.8.5 Function Field	25
3.8.6 Data Field	25
3.8.7 CRC Check Field	25
3.8.8 Coil Register Addressing	25
3.8.9 Access via PCD Write/Read	25
3.8.10 Mapping the Holding Registers to Drive Parameters	26
3.8.11 How to Control the Frequency Converter	27
3.8.12 Function Codes Supported by Modbus RTU	27
3.8.13 Modbus Exception Codes	27
3.9 How to Access Parameters	28
3.9.1 Parameter Handling	28
3.9.2 Storage of Data	28
3.10 Examples	28
3.10.1 Read Holding Registers (03 hex)	28
3.10.2 Preset Single Register (06 hex)	29
3.10.3 Preset Multiple Registers (10 hex)	29
3.10.4 Read/Write Multiple registers (17 hex)	30
3.11 FC Control Profile	30
3.11.1 Control Word According to FC Profile (8–10 Protocol = FC profile)	30
3.11.2 Status Word According to FC Profile (STW) (<i>parameter 8-30 Protocol = FC profile</i>)	32
4 Parameters	34
4.1 Main Menu - Operation and Display - Group 0	34
4.2 Main Menu - Load and Motor - Group 1	40
4.3 Main Menu - Brakes - Group 2	50
4.4 Main Menu - Reference/Ramps - Group 3	52
4.5 Main Menu - Limits/Warnings - Group 4	55
4.6 Main Menu - Digital In/Out - Group 5	58

4.7 Main Menu - Analog In/Out - Group 6	66
4.8 Main Menu - Communications and Options - Group 8	71
4.9 Main Menu - PROFIdrive - Group 9	77
4.10 Main Menu - Smart Logic - Group 13	82
4.11 Main Menu - Special Functions - Group 14	89
4.12 Main Menu - Drive Information - Group 15	93
4.13 Main Menu - Data Readouts - Group 16	96
4.14 Main Menu - Data Readouts 2 - Group 18	101
4.15 Main Menu - FC Closed Loop - Group 20	102
4.16 Main Menu - Application Functions - Group 22	104
4.17 Main Menu - Application Functions 2 - Group 24	113
4.18 Main Menu - Special Features - Group 30	116
5 Diagnostics and Troubleshooting	117
5.1 Alarms and Warnings Overview	117
5.2 Alarm Words	120
5.3 Warning Words	121
5.4 Extended Status Words	122
5.5 Troubleshooting	123
6 Parameter Lists	127
6.1 Parameter Options	127
6.1.1 Default Settings	127
6.1.2 0-** Operation/Display	128
6.1.3 1-** Load and Motor	128
6.1.4 2-** Brakes	130
6.1.5 3-** Reference/Ramps	130
6.1.6 4-** Limits/Warnings	131
6.1.7 5-** Digital In/Out	131
6.1.8 6-** Analog In/Out	132
6.1.9 8-** Comm. and Options	133
6.1.10 9-** PROFIdrive	134
6.1.11 13-** Smart Logic	135
6.1.12 14-** Special Functions	135
6.1.13 15-** Drive Information	136
6.1.14 16-** Data Readouts	137
6.1.15 18-** Info & Readouts	138
6.1.16 20-** Drive Closed Loop	138
6.1.17 22-** Appl. Functions	139
6.1.18 24-** Appl. Functions 2	140
6.1.19 30-** Special Features	140

Index	141
--------------	-----

1 Introduction

1.1 Purpose of the Manual

The programming guide provides information required for commissioning and programming the frequency converter, including complete parameter descriptions.

1.2 Additional Resources

Available literature:

- *VLT® DriveMotor FCP 106/FCM 106 Operating Instructions*, for information required to install and commission the frequency converter.
- *VLT® DriveMotor FCP 106/FCM 106 Design Guide* provides information required for integration of the frequency converter into a diversity of applications.
- *VLT® DriveMotor FCP 106/FCM 106 Programming Guide*, for how to program the unit, including complete parameter descriptions.
- *VLT® LCP Instruction*, for operation of the local control panel (LCP).
- *VLT® LOP Instruction*, for operation of the local operation pad (LOP).
- *Modbus RTU Operating Instructions* and *VLT® DriveMotor FCP 106/FCM 106 BACnet Operating Instructions* for information required for controlling, monitoring, and programming of the frequency converter.
- The *VLT® PROFIBUS DP MCA 101 Installation Guide* provides information about installing the PROFIBUS and troubleshooting.
- The *VLT® PROFIBUS DP MCA 101 Programming Guide* provides information about configuring the system, controlling the frequency converter, accessing the frequency converter, programming, and troubleshooting. It also contains some typical application examples.
- *VLT® Motion Control Tool MCT 10* enables configuration of the frequency converter from a Windows™-based PC environment.
- *Danfoss VLT® Energy Box* software, for energy calculation in HVAC applications.

Technical literature and approvals are available online at vlt-drives.danfoss.com/Support/Service/.

Danfoss VLT® Energy Box software is available at www.danfoss.com/BusinessAreas/DrivesSolutions/, PC software download area.

1.3 Document and Software Version

This manual is regularly reviewed and updated. All suggestions for improvement are welcome. *Table 1.1* shows the document version and the corresponding software version.

In the frequency converter, read the software version in *parameter 15-43 Software Version*.

Edition	Remarks	Software version
MG03N2xx	Software update. PROFIBUS available.	5.00

Table 1.1 Document and Software Version

1.4 Symbols, Abbreviations, and Definitions

The following symbols are used in this manual.

⚠ WARNING

Indicates a potentially hazardous situation which could result in death or serious injury.

⚠ CAUTION

Indicates a potentially hazardous situation which could result in minor or moderate injury. It may also be used to alert against unsafe practices.

NOTICE

Indicates important information, including situations that may result in damage to equipment or property.

60° AVM	60° asynchronous vector modulation
A	Ampere/AMP
AC	Alternating current
AD	Air discharge
AEO	Automatic energy optimization
AI	Analog input
AMA	Automatic motor adaptation
AWG	American wire gauge
°C	Degrees celsius
CD	Constant discharge
CDM	Complete drive module: The frequency converter, feeding section, and auxiliaries
CM	Common mode
CT	Constant torque
DC	Direct current
DI	Digital input
DM	Differential mode
D-TYPE	Drive dependent
EMC	Electromagnetic compatibility

EMF	Electromotive force
ETR	Electronic thermal relay
f _{JOG}	Motor frequency when jog function is activated.
f _M	Motor frequency
f _{MAX}	Maximum output frequency, the frequency converter applies on its output.
f _{MIN}	Minimum motor frequency from the frequency converter
f _{M,N}	Nominal motor frequency
FC	Frequency converter
g	Gram
Hiperface®	Hiperface® is a registered trademark by Stegmann.
HO	High overload
hp	Horse power
HTL	HTL encoder (10–30 V) pulses - High-voltage transistor logic
Hz	Hertz
I _{INV}	Rated inverter output current
I _{LIM}	Current limit
I _{M,N}	Nominal motor current
I _{VLT,MAX}	Maximum output current
I _{VLT,N}	Rated output current supplied by the frequency converter.
kHz	Kilohertz
LCP	Local control panel
lsb	Least significant bit
m	Meter
mA	Milliampere
MCM	Mille circular mil
MCT	Motion control tool
mH	Inductance in milli Henry
mm	Millimeter
ms	Millisecond
msb	Most significant bit
η _{VLT}	Efficiency of the frequency converter defined as ratio between power output and power input.
nF	Capacitance in nano Farad
NLCP	Numerical local control panel
Nm	Newton meter
NO	Normal overload
n _s	Synchronous motor speed
Online/ Offline Parameters	Changes to online parameters are activated immediately after the data value is changed.
P _{br,cont.}	Rated power of the brake resistor (average power during continuous braking).
PCB	Printed circuit board

PCD	Process data
PDS	Power drive system: a CDM and a motor
PELV	Protective extra low voltage
P _m	Frequency converter nominal output power as high overload (HO).
P _{M,N}	Nominal motor power
PM motor	Permanent magnet motor
Process PID	PID (Proportional Integrated Differential) regulator that maintains the speed, pressure, temperature, and so on.
R _{br,nom}	Nominal resistor value that ensures a brake power on the motor shaft of 150/160% for 1 minute
RCD	Residual current device
Regen	Regenerative terminals
R _{min}	Minimum permissible brake resistor value by frequency converter
RMS	Root mean square
RPM	Revolutions per minute
R _{rec}	Recommended brake resistor resistance of Danfoss brake resistors
s	Second
SFAVM	Stator flux-oriented asynchronous vector modulation
STW	Status word
SMPS	Switch mode power supply
THD	Total harmonic distortion
T _{LIM}	Torque limit
TTL	TTL encoder (5 V) pulses - transistor transistor logic
U _{M,N}	Nominal motor voltage
V	Volts
VT	Variable torque
VVC ⁺	Voltage vector control plus

Table 1.2 Abbreviations
Conventions

Numbered lists indicate procedures.

Bullet lists indicate other information and description of illustrations.

Italicized text indicates:

- Cross-reference.
- Link.
- Footnote.
- Parameter name, parameter group name, parameter option.

All dimensions are in mm (inch).

* indicates a default setting of a parameter.

1.5 Electrical Overview

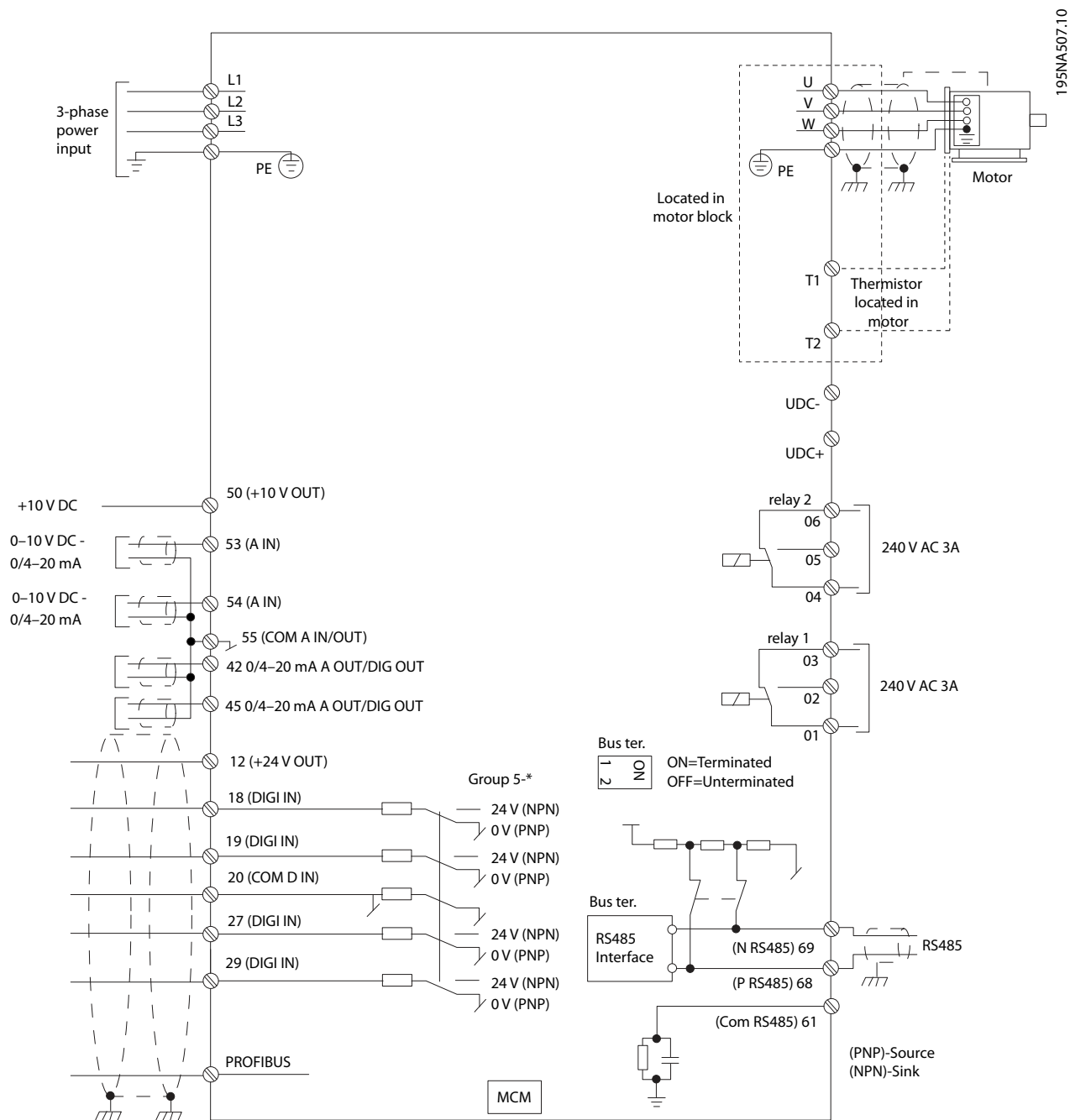

Illustration 1.1 Electrical Overview

2 Programming

2

2.1 Programming with MCT 10 Set-up Software

The frequency converter can be programmed from the LCP, or from a PC via the RS485 COM port by installing the MCT 10 Set-up Software. Refer to *chapter 1.2 Additional Resources* for more details about the software.

2.2 Graphical Local Control Panel (GLCP)

The GLCP is divided into 4 functional sections.

- A. Alphanumeric display.
- B. Menu selection.
- C. Navigation keys and indicator lights (LEDs).
- D. Operation keys and indicator lights (LEDs).

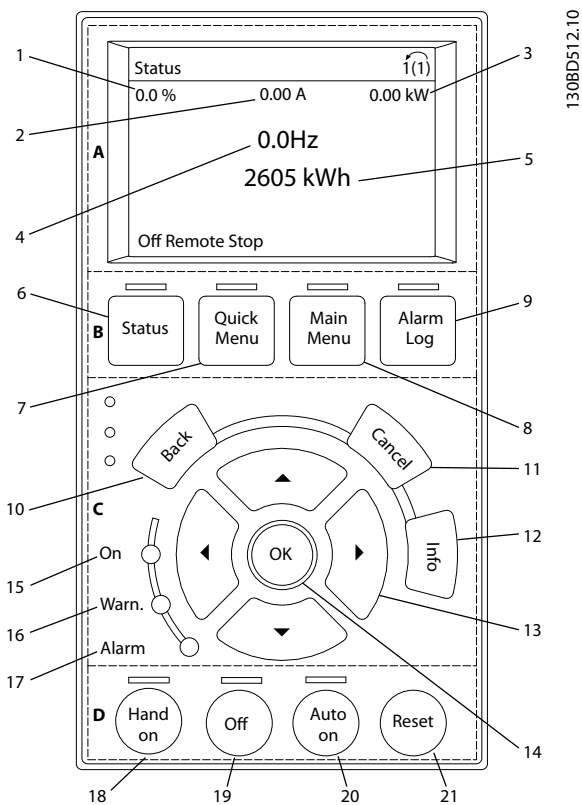

Illustration 2.1 Graphical Local Control Panel (GLCP)

A. Display area

The display area is activated when the frequency converter receives power from mains voltage, a DC bus terminal, or a 24 V DC external supply.

The information shown on the GLCP can be customized for user application. Select options in the Quick Menu Q3-13 *Display settings*.

Call-out	Display	Parameter number	Default setting
1	1.1	0-20	Reference %
2	1.2	0-21	Motor current
3	1.3	0-22	Power [kW]
4	2	0-23	Frequency
5	3	0-24	kWh counter

Table 2.1 Legend to Illustration 2.1

B. Display menu key

Menu keys are used for menu access for parameter set-up, toggling through status display modes during normal operation, and viewing fault log data.

Callout	Key	Function
6	Status	Shows operational information.
7	Quick Menu	Allows access to programming parameters for initial set-up instructions and many detailed application instructions.
8	Main Menu	Allows access to all programming parameters.
9	Alarm Log	Shows a list of current warnings, the last 10 alarms, and the maintenance log.

Table 2.2 Legend to Illustration 2.1

C. Navigation keys and indicator lights (LEDs)

Navigation keys are used for programming functions and moving the display cursor. The navigation keys also provide speed control in local operation. There are also 3 frequency converter status indicator lights in this area.

Callout	Key	Function
10	Back	Reverts to the previous step or list in the menu structure.
11	Cancel	Cancels the last change or command as long as the display mode has not changed.
12	Info	Press for a definition of the function shown.
13	Navigation keys	Press to move between items in the menu.
14	OK	Press to access parameter groups or to enable a selection.

Table 2.3 Legend to Illustration 2.1

Call-out	Indicator	Light	Function
15	ON	Green	The ON light activates when the frequency converter receives power from mains voltage, a DC bus terminal, or a 24 V external supply.
16	WARN	Yellow	When warning conditions are met, the yellow WARN light turns on, and text appears in the display area identifying the problem.
17	ALARM	Red	A fault condition causes the red alarm light to flash, and an alarm text is shown.

Table 2.4 Legend to Illustration 2.1

D. Operation keys and indicator lights (LEDs)

Operation keys are at the bottom of the GLCP.

Callout	Key	Function
18	Hand On	Starts the frequency converter in local control. <ul style="list-style-type: none"> An external stop signal by control input or serial communication overrides the local hand on.
19	Off	Stops the motor but does not remove power to the frequency converter.
20	Auto On	Puts the system in remote operational mode. <ul style="list-style-type: none"> Responds to an external start command by control terminals or serial communication.
21	Reset	Resets the frequency converter manually after a fault has been cleared.

Table 2.5 Legend to Illustration 2.1

NOTICE

To adjust the display contrast, press [Status] and [▲]/[▼].

2.3 GLCP Menus

2.3.1 Status Menu

In the *Status* menu, the selection options are:

- Motor frequency [Hz], *parameter 16-13 Frequency*.
- Motor current [A], *parameter 16-14 Motor current*.
- Motor speed reference in percentage [%], *parameter 16-02 Reference [%]*.
- Feedback, *parameter 16-52 Feedback[Unit]*.
- Motor power *parameter 16-10 Power [kW]* for kW, *parameter 16-11 Power [hp]* for hp. If *parameter 0-03 Regional Settings* is set to [1] North

America, motor power is shown in hp instead of kW.

- Custom readout *parameter 16-09 Custom Readout*.

2.3.2 Quick Menu

Use the Quick Menu to program the most common functions. The Quick Menu consists of:

- Wizard for open-loop applications. See *chapter 2.3.4 Configuration for Open-loop Applications* for details.
- Wizard for closed-loop applications. See *chapter 2.3.5 Set-up Wizard for Closed-loop Applications* for details.
- Motor set-up. See *chapter 2.3.6 Quick Menu Motor Set-up* for details.
- Changes made.

2.3.3 Main Menu

The *Main Menu* is used for access to and programming of all parameters. The *Main Menu* parameters can be accessed readily unless a password has been created via *parameter 0-60 Main Menu Password*.

For most applications, it is not necessary to access the *Main Menu* parameters. Instead the *Quick Menu* provides the simplest and quickest access to the parameters which are typically required.

2.3.4 Configuration for Open-loop Applications

This section guides the installer through the set-up of the frequency converter in a clear and structured manner to set up an open-loop application. An open-loop application does not utilize a feedback signal from the process.

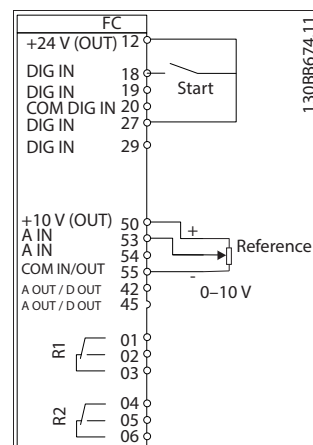

Illustration 2.2 Principle Wiring for Open-loop Applications

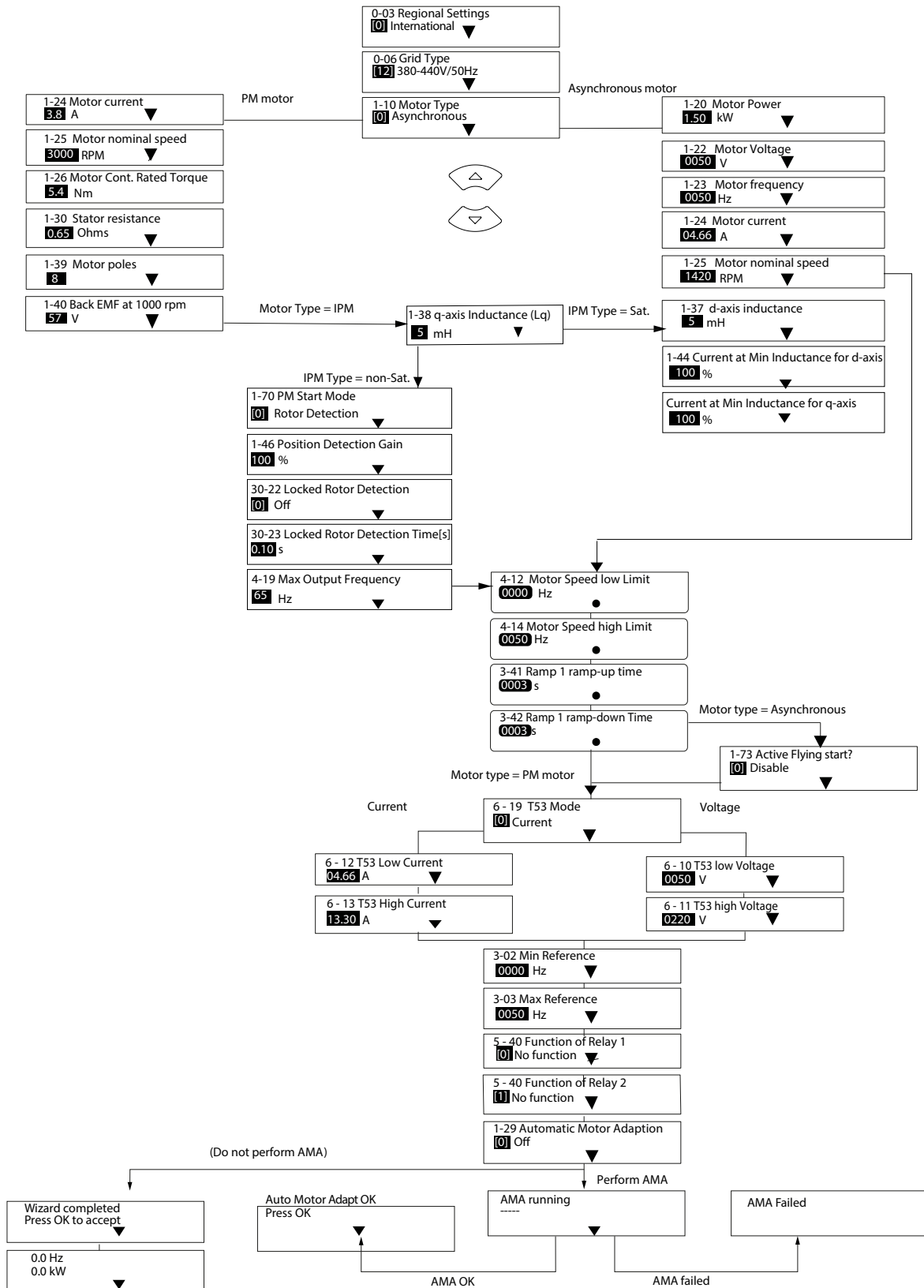
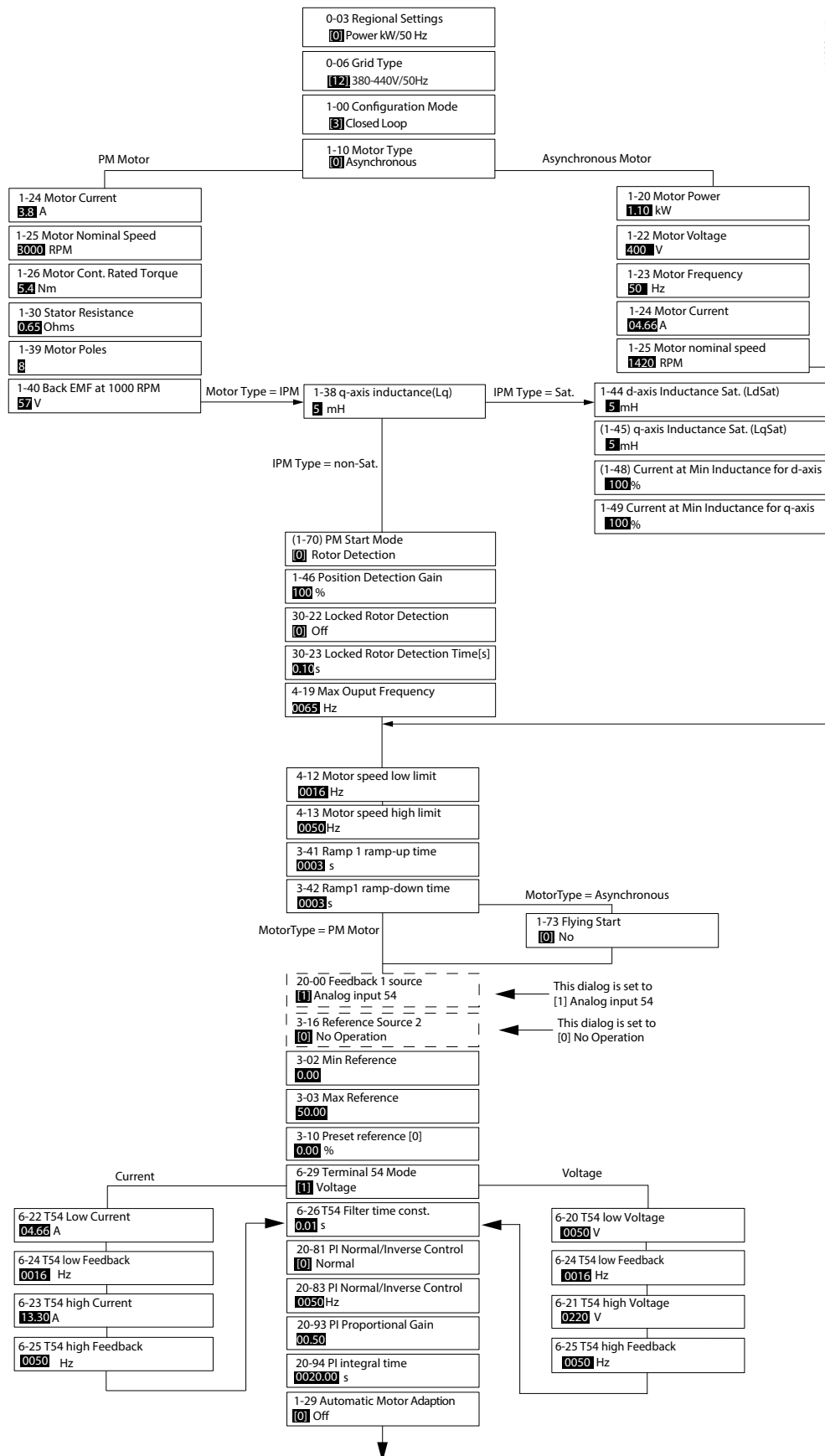

Illustration 2.3 Configuration for Open-loop Applications

2.3.5 Set-up Wizard for Closed-loop Applications



195NA417.11

Illustration 2.4 Closed-loop Set-up Wizard

2.3.6 Quick Menu Motor Set-up

The Quick Menu Motor Set-up guides the installer through setting of the required motor parameters.

NOTICE

MOTOR OVERLOAD PROTECTION

Thermal protection of the motor is recommended. Especially when running at low speed, the cooling from the integrated motor fan is often not sufficient.

- Use PTC. See *chapter Motor Connection* in *VLT® DriveMotor FCP 106/FCM 106 Operating Instructions*, or
- Enable motor thermal protection by setting *parameter 1-90 Motor Thermal Protection* to [4] ETR trip 1.

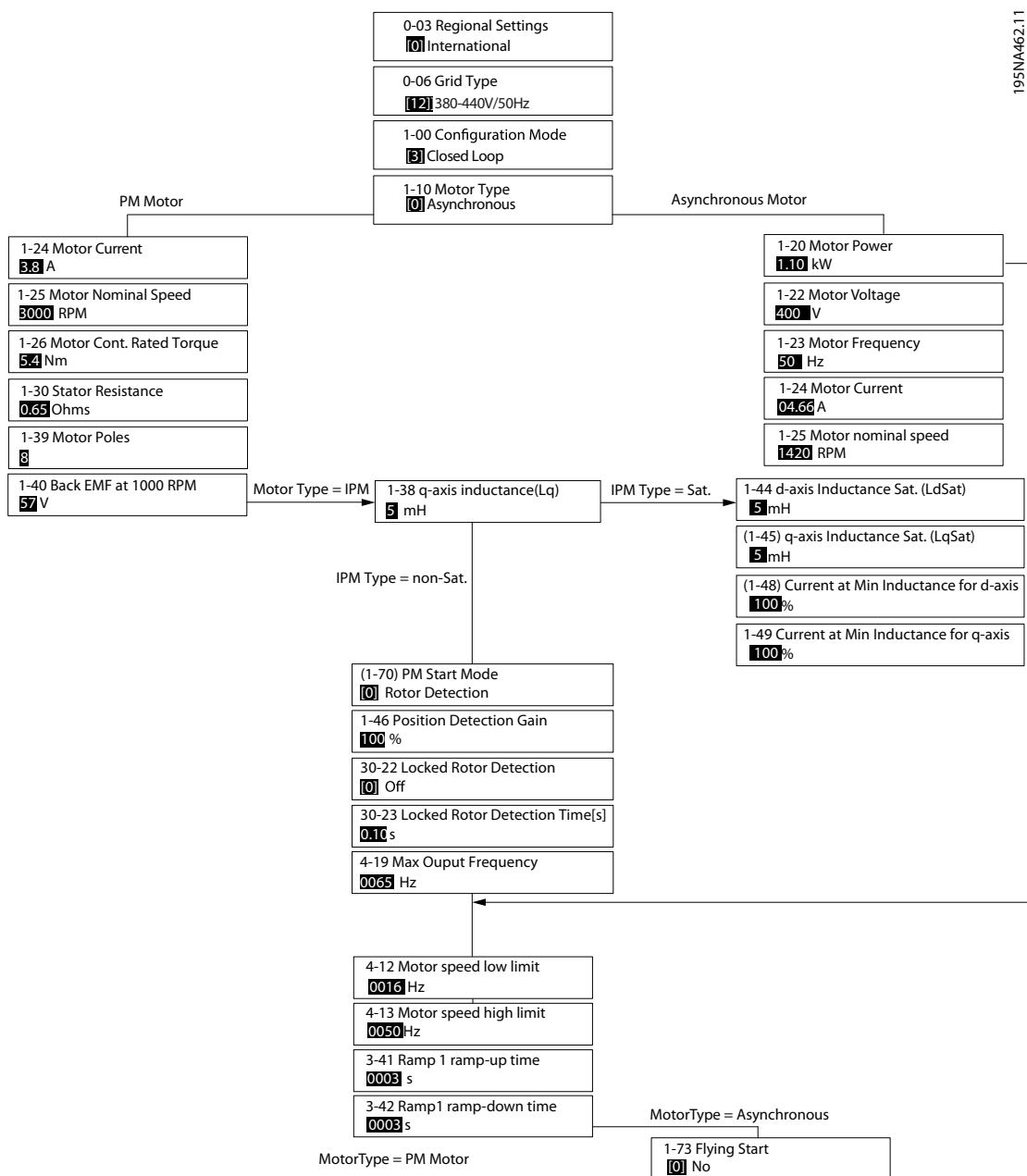

Illustration 2.5 Quick Menu Motor Set-up

2.4 Programming Parameters

Procedure:

1. Press [Menu] until the arrow in the display indicates the wanted menu: *Quick Menu* or *Main Menu*.
2. To browse through the parameter groups, press [▲] [▼].
3. To select a parameter group, press [OK].
4. To browse through the parameters in the specific group, press [▲] [▼].
5. To select the parameter, press [OK].
6. To change the parameter value, press [▲] [▼] [▶].
7. To save the new setting, press [OK]. To abort, press [Back].
8. To return to the previous menu, press [Back].

2.5 Back-up and Copying Parameter Settings

NOTICE

Stop the motor before backing-up or copying parameter settings.

Data storage in LCP

Once the set-up of a frequency converter is complete, store the data in the LCP. Alternatively, use a PC with the MCT 10 Set-up Software to perform the same back-up.

1. Go to *parameter 0-50 LCP Copy*.
2. Press [OK].
3. Select [1] *All to LCP*.
4. Press [OK].

Data transfer from LCP to frequency converter

Connect the LCP to another frequency converter and copy the parameter settings to this frequency converter as well.

1. Go to *parameter 0-50 LCP Copy*.
2. Press [OK].
3. Select [2] *All from LCP*.
4. Press [OK].

2.6 Restoring Default Settings

Select initialization mode according to the requirement for retaining parameter settings.

Recommended initialization (via *parameter 14-22 Operation Mode*).

Use this method to initialize the frequency converter without resetting communication settings.

1. Select *parameter 14-22 Operation Mode*.
2. Press [OK].
3. Select [2] *initialization* and Press [OK].
4. Cut off the mains supply and wait until the display turns off.
5. Reconnect the mains supply.

The frequency converter is now reset, except for the following parameters:

- *Parameter 0-03 Regional Settings.*
- *Parameter 8-30 Protocol.*
- *Parameter 8-31 Address.*
- *Parameter 8-32 Baud Rate.*
- *Parameter 8-33 Parity / Stop Bits.*
- *Parameter 8-35 Minimum Response Delay.*
- *Parameter 8-36 Maximum Response Delay.*
- *Parameter 8-70 BACnet Device Instance.*
- *Parameter 8-72 MS/TP Max Masters.*
- *Parameter 8-73 MS/TP Max Info Frames.*
- *Parameter 8-74 "I am" Service.*
- *Parameter 8-75 Intialisation Password.*
- *Parameter 15-00 Operating hours.*
- *Parameter 15-03 Power Up's.*
- *Parameter 15-04 Over Temp's.*
- *Parameter 15-05 Over Volt's.*
- *Parameter 15-30 Alarm Log: Error Code.*
- *Parameter group 15-4* Drive identification parameters.*
- *Parameter 1-06 Clockwise Direction.*

2

Two-finger initialization

Use this method to initialize the frequency converter, including reset of communication settings.

1. Power off the frequency converter.
2. Press [OK] and [Menu] simultaneously.
3. Power up the frequency converter while still pressing the above-mentioned keys for 10 s.

The frequency converter is now reset, except for the following parameters:

- *Parameter 0-03 Regional Settings.*
- *Parameter 15-00 Operating hours.*
- *Parameter 15-03 Power Up's.*
- *Parameter 15-04 Over Temp's.*
- *Parameter 15-05 Over Volt's.*
- *Parameter group 15-4* Drive identification parameters*

Alarm 80, Drive initialised appears as confirmation that parameters are initialized. Press [Reset].

3 RS485 Installation and Set-up

3.1 RS485

3.1.1 Overview

RS485 is a 2-wire bus interface compatible with multi-drop network topology. Nodes can be connected as a bus or via drop cables from a common trunk line. A total of 32 nodes can be connected to 1 network segment. Repeaters divide network segments, see *Illustration 3.1*.

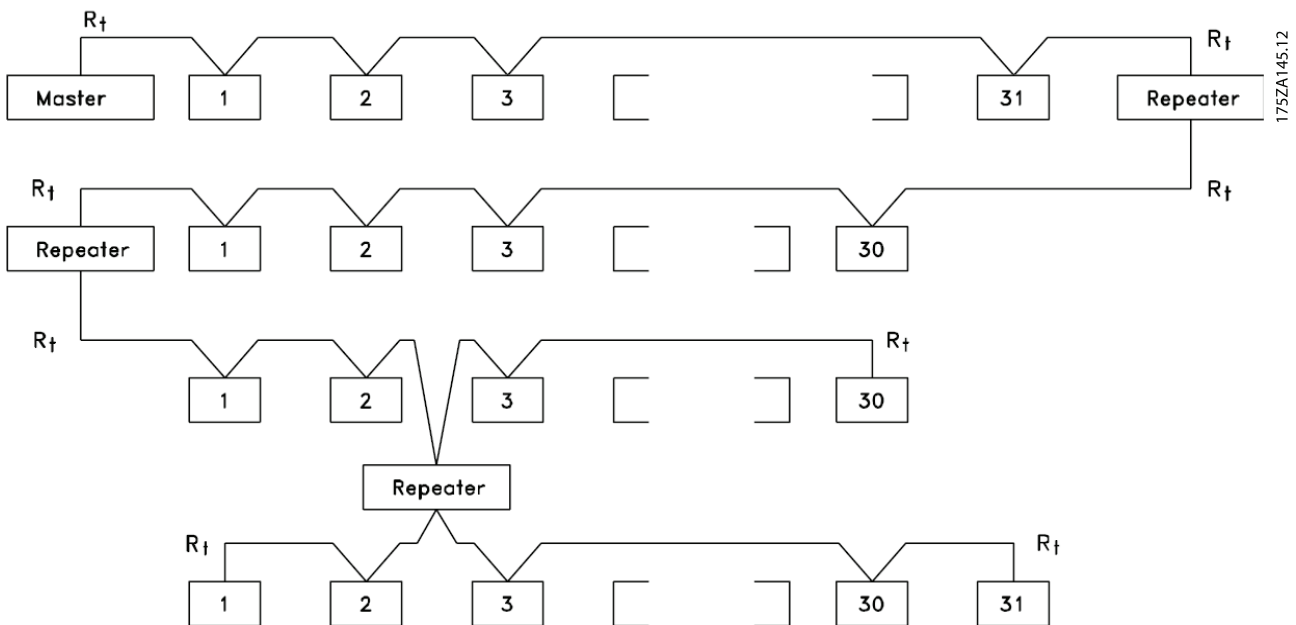

Illustration 3.1 RS485 Bus Interface

NOTICE

Each repeater functions as a node within the segment in which it is installed. Each node connected within a given network must have a unique node address across all segments.

Terminate each segment at both ends, using either the termination switch (S800) of the frequency converters or a biased termination resistor network. Always use screened twisted pair (STP) cable for bus cabling, and follow good common installation practice.

Low-impedance ground connection of the screen at every node is important, including at high frequencies. Thus, connect a large surface of the screen to ground, for example with a cable clamp or a conductive cable gland. It may be necessary to apply potential-equalizing cables to maintain the same ground potential throughout the network - particularly in installations with long cables.

To prevent impedance mismatch, always use the same type of cable throughout the entire network. When connecting a motor to the frequency converter, always use screened motor cable.

Cable	Screened twisted pair (STP)
Impedance [Ω]	120
Cable length [m]	Maximum 1200 (including drop lines) Maximum 500 station-to-station

Table 3.1 Cable Specifications

3.1.2 EMC Precautions

NOTICE

Observe relevant national and local regulations regarding protective earth connection. Failure to ground the cables properly can result in communication degradation and equipment damage. To avoid coupling of high-frequency noise between the cables, the RS485 communication cable must be kept away from motor and brake resistor cables. Normally, a distance of 200 mm (8 inches) is sufficient. Maintain the greatest possible distance between the cables, especially where cables run in parallel over long distances. When crossing is unavoidable, the RS485 cable must cross motor and brake resistor cables at an angle of 90°.

3

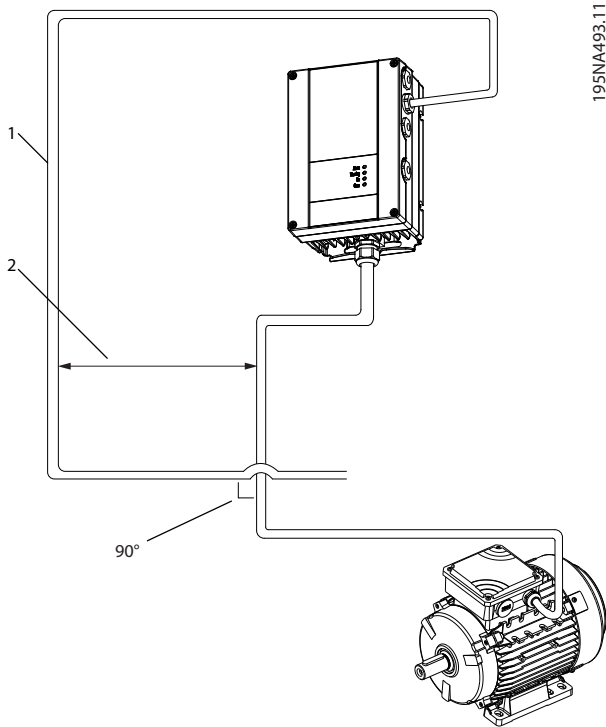

1	Fieldbus cable
2	Minimum 200 mm (8 in) distance

Illustration 3.2 Minimum Distance between Communication and Power Cables

3.1.3 Network Connection

Connect the frequency converter to the R4S85 network as follows (see also *Illustration 3.3*):

1. Connect signal wires to terminal 68 (P+) and terminal 69 (N-) on the main control board of the frequency converter.
2. Connect the cable screen to the cable clamps.
3. Terminal 61 is normally not used. However, when there is a large potential difference between frequency converters, connect the screen of the RS485 cable to terminal 61. Terminal 61 has an RC filter to eliminate current noise on the cable.

NOTICE

INSULATION REQUIREMENTS, MH1

For control card and relay card wires, the minimum required insulation is 300 V and 75 °C (167 °F).

NOTICE

Screened, twisted-pair cables are recommended to reduce noise between conductors.

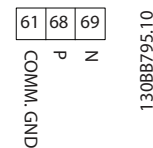

COMM. GND	Communication ground
P	(P+) Positive
N	(N-) Negative

Illustration 3.3 Network Connection

4. Set the control card DIP switch to ON to terminate the RS485 bus, and activate RS485. For position of DIP switch, see *Illustration 3.4*. The factory setting for the DIP switch is OFF.

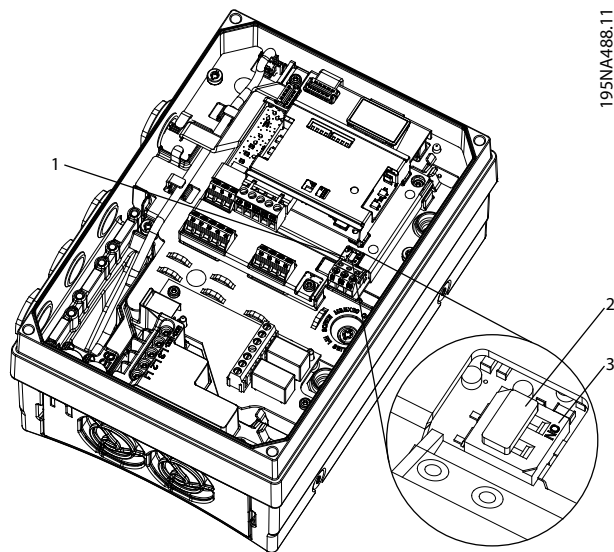

1	DIP switch
2	DIP switch set to factory setting, OFF position
3	DIP switch ON position

Illustration 3.4 DIP Switch set to Factory Setting

3.1.4 Parameter Settings for Modbus Communication

Parameter	Function
Parameter 8-30 Protocol	Select the application protocol to run for the RS485 interface.
Parameter 8-31 Address	Set the node address. NOTICE The address range depends on the protocol selected in parameter 8-30 Protocol.
Parameter 8-32 Baud Rate	Set the baud rate. NOTICE The default baud rate depends on the protocol selected in parameter 8-30 Protocol.
Parameter 8-33 Parity / Stop Bits	Set the parity and number of stop bits. NOTICE The default selection depends on the protocol selected in parameter 8-30 Protocol.
Parameter 8-35 Minimum Response Delay	Specify a minimum delay time between receiving a request and transmitting a response. This function is for overcoming modem turnaround delays.

Parameter	Function
Parameter 8-36 Maximum Response Delay	Specify a maximum delay time between transmitting a request and receiving a response.
Parameter 8-37 Maximum Inter-character delay	If transmission is interrupted, specify a maximum delay time between 2 received bytes to ensure timeout. NOTICE The default selection depends on the protocol selected in parameter 8-30 Protocol.

Table 3.2 Modbus Communication Parameter Settings

3.2 FC Protocol

3.2.1 FC Protocol Overview

The FC protocol, also referred to as FC bus or standard bus, is the Danfoss standard fieldbus. It defines an access technique according to the master/slave principle for communications via a fieldbus.

1 master and a maximum of 126 slaves can be connected to the bus. The master selects the individual slaves via an address character in the telegram. A slave itself can never transmit without first being requested to do so, and direct message transfer between the individual slaves is not possible. Communications occur in the half-duplex mode. The master function cannot be transferred to another node (single-master system).

The physical layer is RS485, thus utilizing the RS485 port built into the frequency converter. The FC protocol supports different telegram formats:

- A short format of 8 bytes for process data.
- A long format of 16 bytes that also includes a parameter channel.
- A format used for texts.

3.2.2 FC with Modbus RTU

The FC protocol provides access to the control word and bus reference of the frequency converter.

The control word allows the Modbus master to control several important functions of the frequency converter.

- Start.
- Stop of the frequency converter in various ways:
 - Coast stop.
 - Quick stop.

- DC Brake stop.
- Normal (ramp) stop.
- Reset after a fault trip.
- Run at various preset speeds.
- Run in reverse.
- Change of the active set-up.
- Control of the 2 relays built into the frequency converter.

The bus reference is commonly used for speed control. It is also possible to access the parameters, read their values, and where possible, write values to them. Accessing the parameters offers a range of control options, including controlling the setpoint of the frequency converter when its internal PI controller is used.

3.3 Network Configuration

To enable the FC protocol for the frequency converter, set the following parameters.

Parameter	Setting
Parameter 8-30 Protocol	FC
Parameter 8-31 Address	1-126
Parameter 8-32 Baud Rate	2400-115200
Parameter 8-33 Parity / Stop Bits	Even parity, 1 stop bit (default)

Table 3.3 Parameters to Enable the Protocol

3.4 FC Protocol Message Framing Structure

3.4.1 Content of a Character (byte)

Each character transferred begins with a start bit. Then 8 data bits are transferred, corresponding to a byte. Each character is secured via a parity bit. This bit is set at 1 when it reaches parity. Parity is when there is an equal number of 1s in the 8 data bits and the parity bit in total. A stop bit completes a character, thus consisting of 11 bits in all.

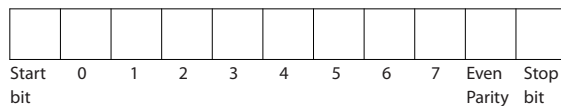

195NA036.10

Illustration 3.5 Content of a Character

3.4.2 Telegram Structure

Each telegram has the following structure:

1. Start character (STX)=02 hex.
2. A byte denoting the telegram length (LGE).
3. A byte denoting the frequency converter address (ADR).

Several data bytes (variable, depending on the type of telegram) follow.

A data control byte (BCC) completes the telegram.

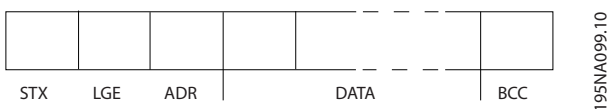

Illustration 3.6 Telegram Structure

3.4.3 Telegram Length (LGE)

The telegram length is the number of data bytes plus the address byte ADR and the data control byte BCC.

4 data bytes	LGE=4+1+1=6 bytes
12 data bytes	LGE=12+1+1=14 bytes
Telegrams containing texts	$10^{11}+n$ bytes

Table 3.4 Length of Telegrams

1) The 10 is the fixed characters, while the n is variable (depending on the length of the text).

3.4.4 Frequency Converter Address (ADR)

Address format 1–126

- Bit 7=1 (address format 1–126 active).
- Bit 0–6=frequency converter address 1–126.
- Bit 0–6=0 Broadcast.

The slave returns the address byte unchanged to the master in the response telegram.

3.4.5 Data Control Byte (BCC)

The checksum is calculated as an XOR-function. Before the first byte in the telegram is received, the calculated checksum is 0.

3.4.6 The Data Field

The structure of data blocks depends on the type of telegram. There are 3 telegram types, and the type applies for both control telegrams (master⇒slave) and response telegrams (slave⇒master).

3

The 3 types of telegram are:

Process block (PCD)

The PCD is made up of a data block of 4 bytes (2 words) and contains:

- Control word and reference value (from master to slave).
- Status word and present output frequency (from slave to master).



130BA269.10

Illustration 3.7 Process Block

Parameter block

The parameter block is used to transfer parameters between master and slave. The data block is made up of 12 bytes (6 words) and also contains the process block.

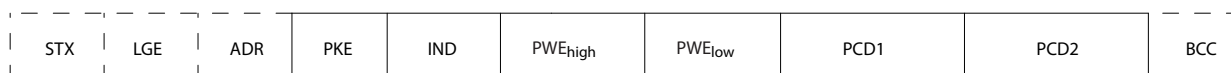

130BA271.10

Illustration 3.8 Parameter Block

Text block

The text block is used to read texts via the data block.

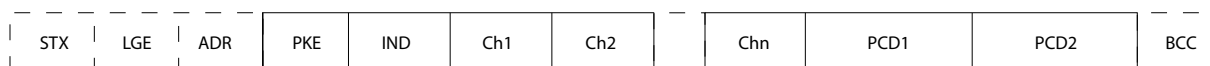

130BA270.10

Illustration 3.9 Text Block

3.4.7 The PKE Field

The PKE field contains 2 subfields: Parameter command and response (AK) and Parameter number (PNU):

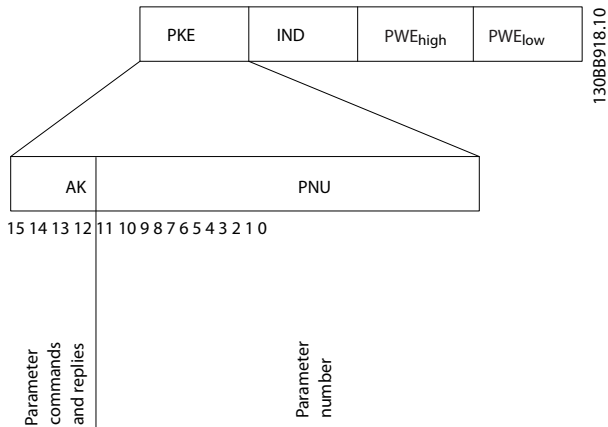

Illustration 3.10 PKE Field

Bits number 12–15 transfer parameter commands from master to slave and return processed slave responses to the master.

Parameter commands master⇒slave				
Bit number				Parameter command
15	14	13	12	
0	0	0	0	No command
0	0	0	1	Read parameter value
0	0	1	0	Write parameter value in RAM (word)
0	0	1	1	Write parameter value in RAM (double word)
1	1	0	1	Write parameter value in RAM and EEPROM (double word)
1	1	1	0	Write parameter value in RAM and EEPROM (word)
1	1	1	1	Read text

Table 3.5 Parameter Commands

Response slave⇒master				
Bit number				Response
15	14	13	12	
0	0	0	0	No response
0	0	0	1	Parameter value transferred (word)
0	0	1	0	Parameter value transferred (double word)
0	1	1	1	Command cannot be performed
1	1	1	1	Text transferred

Table 3.6 Response

If the command cannot be performed, the slave sends this response:

0111 Command cannot be performed

- and issues the following fault report in the parameter value:

Fault code	+ Specification
0	Illegal parameter number
2	Upper or lower limit exceeded
3	Subindex corrupted
4	No array
5	Wrong data type
6	Not used
7	Not used
17	Not while running
18	Other error
23	Parameter database is busy
100	
>100	
130	No bus access for this parameter
132	No LCP access
255	No error

Table 3.7 Slave Report

3.4.8 Parameter Number (PNU)

Bit numbers 0–11 transfer parameter numbers. The function of the relevant parameter is defined in the parameter description in *chapter 2 Programming*.

3.4.9 Index (IND)

The index is used with the parameter number to read/write access parameters with an index, for example, *parameter 15-30 Alarm Log: Error Code*. The index consists of 2 bytes; a low byte, and a high byte.

Only the low byte is used as an index.

3.4.10 Parameter Value (PWE)

The parameter value block consists of 2 words (4 bytes), and the value depends on the defined command (AK). The master prompts for a parameter value when the PWE block contains no value. To change a parameter value (write), write the new value in the PWE block and send from the master to the slave.

When a slave responds to a parameter request (read command), the present parameter value in the PWE block is transferred and returned to the master. If a parameter contains several data options, for example *parameter 0-01 Language*, select the data value by entering the value in the PWE block. Serial communication is only

capable of reading parameters containing data type 9 (text string).

Parameter 15-40 FC Type to parameter 15-53 Power Card Serial Number contain data type 9.

For example, read the unit size and mains voltage range in parameter 15-40 FC Type. When a text string is transferred (read), the length of the telegram is variable, and the texts are of different lengths. The telegram length is defined in the 2nd byte of the telegram (LGE). When using text transfer, the index character indicates whether it is a read or a write command.

To read a text via the PWE block, set the parameter command (AK) to F hex. The index character high-byte must be 4.

3.4.11 Data Types Supported by the Frequency Converter

Unsigned means that there is no operational sign in the telegram.

Data types	Description
3	Integer 16
4	Integer 32
5	Unsigned 8
6	Unsigned 16
7	Unsigned 32
9	Text string

Table 3.8 Data Types

3.4.12 Conversion

The various attributes of each parameter are shown in chapter 4 Parameters. Parameter values are transferred as whole numbers only. Conversion factors are used to transfer decimals.

Parameter 4-12 Motor Speed Low Limit [Hz] has a conversion factor of 0.1. To preset the minimum frequency to 10 Hz, transfer the value 100. A conversion factor of 0.1 means that the value transferred is multiplied by 0.1. The value 100 is thus perceived as 10.0.

Conversion index	Conversion factor
74	3600
2	100
1	10
0	1
-1	0.1
-2	0.01
-3	0.001
-4	0.0001
-5	0.00001

Table 3.9 Conversion

3.4.13 Process Words (PCD)

The block of process words is divided into 2 blocks of 16 bits, which always occur in the defined sequence.

PCD 1	PCD 2
Control telegram (master→slave control word)	Reference value
Control telegram (slave→master) status word	Present output frequency

Table 3.10 Process Words (PCD)

3.5 Examples

3.5.1 Writing a Parameter Value

Change parameter 4-14 Motor Speed High Limit [Hz] to 100 Hz.

Write the data in EEPROM.

PKE=E19E hex - Write single word in parameter 4-14 Motor Speed High Limit [Hz]:

- IND=0000 hex.
- PWEHIGH=0000 hex.
- PWELOW=03E8 hex.

Data value 1000, corresponding to 100 Hz, see chapter 3.4.12 Conversion.

The telegram looks like Illustration 3.11.

E19E	H	0000	H	0000	H	03E8	H
PKE		IND		PWE high		PWE low	

Illustration 3.11 Telegram

NOTICE

Parameter 4-14 Motor Speed High Limit [Hz] is a single word, and the parameter command for write in EEPROM is E. Parameter 4-14 Motor Speed High Limit [Hz] is 19E in hexadecimal.

The response from the slave to the master is shown in Illustration 3.12.

119E	H	0000	H	0000	H	03E8	H
PKE		IND		PWE _{high}		PWE _{low}	

130BA093.10

Illustration 3.12 Response from Master

3.5.2 Reading a Parameter Value

Read the value in parameter 3-41 Ramp 1 Ramp Up Time.

PKE=1155 hex - Read parameter value in parameter 3-41 Ramp 1 Ramp Up Time:

- IND=0000 hex.
- PWE_{HIGH}=0000 hex.
- PWE_{LOW}=0000 hex.

1155	H	0000	H	0000	H	0000	H
PKE		IND		PWE _{high}		PWE _{low}	

130BA094.10

Illustration 3.13 Telegram

If the value in parameter 3-41 Ramp 1 Ramp Up Time is 10 s, the response from the slave to the master is shown in Illustration 3.14.

1155	H	0000	H	0000	H	03E8	H
PKE		IND		PWE _{high}		PWE _{low}	

130BA267.10

Illustration 3.14 Response

3E8 hex corresponds to 1000 decimal. The conversion index for parameter 3-41 Ramp 1 Ramp Up Time is -2, that is, 0.01.

Parameter 3-41 Ramp 1 Ramp Up Time is of the type Unsigned 32.

3.6 Modbus RTU Overview

3.6.1 Prerequisite Knowledge

Danfoss assumes that the installed controller supports the interfaces in this document, and strictly observes all requirements and limitations stipulated in the controller and frequency converter.

The built-in Modbus RTU (Remote Terminal Unit) is designed to communicate with any controller that supports the interfaces defined in this document. It is assumed that the user has full knowledge of the capabilities and limitations of the controller.

3.6.2 What the User Should Already Know

The built-in Modbus RTU (Remote Terminal Unit) is designed to communicate with any controller that supports the interfaces defined in this document. It is assumed that the user has full knowledge of the capabilities and limitations of the controller.

3.6.3 Overview

Regardless of the type of physical communication networks, this section describes the process a controller uses to request access to another device. This process includes how the Modbus RTU responds to requests from another device, and how errors are detected and reported. It also establishes a common format for the layout and contents of message fields.

During communications over a Modbus RTU network, the protocol:

- Determines how each controller learns its device address.
- Recognizes a message addressed to it.
- Determines which actions to take.
- Extracts any data or other information contained in the message.

If a reply is required, the controller constructs the reply message and sends it.

Controllers communicate using a master/slave technique in which only the master can initiate transactions (called queries). Slaves respond by supplying the requested data to the master, or by acting as requested in the query. The master can address individual slaves, or initiate a broadcast message to all slaves. Slaves return a response to queries that are addressed to them individually. No responses are returned to broadcast queries from the master.

The Modbus RTU protocol establishes the format for the master's query by providing the following information:

- The device (or broadcast) address.
- A function code defining the requested action.
- Any data to be sent.
- An error-checking field.

The slave's response message is also constructed using Modbus protocol. It contains fields confirming the action taken, any data to be returned, and an error-checking field. If an error occurs in receipt of the message, or if the slave is unable to perform the requested action, the slave constructs and sends an error message. Alternatively, a timeout occurs.

3.6.4 Frequency Converter with Modbus RTU

The frequency converter communicates in Modbus RTU format over the built-in RS485 interface. Modbus RTU provides access to the control word and bus reference of the frequency converter.

The control word allows the Modbus master to control several important functions of the frequency converter:

- Start.
- Various stops:
 - Coast stop.
 - Quick stop.
 - DC-brake stop.
 - Normal (ramp) stop.
- Reset after a fault trip.
- Run at various preset speeds.
- Run in reverse.
- Change the active set-up.
- Control the frequency converter's built-in relay.

The bus reference is commonly used for speed control. It is also possible to access the parameters, read their values, and, where possible, write values to them. Accessing the parameters offers a range of control options, including controlling the setpoint of the frequency converter when its internal PI controller is used.

3.7 Network Configuration

To enable Modbus RTU on the frequency converter, set the following parameters:

Parameter	Setting
Parameter 8-30 Protocol	Modbus RTU
Parameter 8-31 Address	1–247
Parameter 8-32 Baud Rate	2400–115200
Parameter 8-33 Parity / Stop Bits	Even parity, 1 stop bit (default)

Table 3.11 Network Configuration

3.8 Modbus RTU Message Framing Structure

3.8.1 Introduction

The controllers are set up to communicate on the Modbus network using RTU (remote terminal unit) mode, with each byte in a message containing 2 4-bit hexadecimal characters. The format for each byte is shown in Table 3.12.

Start bit	Data byte						Stop/parity	Stop

Table 3.12 Format for Each Byte

Coding system	8-bit binary, hexadecimal 0–9, A–F. 2 hexadecimal characters contained in each 8-bit field of the message.
Bits per byte	<ul style="list-style-type: none"> • 1 start bit. • 8 data bits, least significant bit sent first. • 1 bit for even/odd parity; no bit for no parity. • 1 stop bit if parity is used; 2 bits if no parity.
Error check field	Cyclic redundancy check (CRC).

Table 3.13 Byte Details

3.8.2 Modbus RTU Message Structure

The transmitting device places a Modbus RTU message into a frame with a known beginning and ending point. This allows receiving devices to begin at the start of the message, read the address portion, determine which device is addressed (or all devices, if the message is broadcast), and to recognize when the message is completed. Partial messages are detected and errors set as a result. Characters for transmission must be in hexadecimal 00 to FF format in each field. The frequency converter continuously monitors the network bus, also

during silent intervals. When the first field (the address field) is received, each frequency converter or device decodes it to determine which device is being addressed. Modbus RTU messages addressed to 0 are broadcast messages. No response is permitted for broadcast messages. A typical message frame is shown in *Table 3.14*.

Start	Address	Function	Data	CRC check	End
T1-T2-T3-T4	8 bits	8 bits	N x 8 bits	16 bits	T1-T2-T3-T4

Table 3.14 Typical Modbus RTU Message Structure

3.8.3 Start/Stop Field

Messages start with a silent period of at least 3.5 character intervals. The silent period is implemented as a multiple of character intervals at the selected network baud rate (shown as Start T1-T2-T3-T4). The first field to be transmitted is the device address. Following the last transmitted character, a similar period of at least 3.5 character intervals marks the end of the message. A new message can begin after this period.

The entire message frame must be transmitted as a continuous stream. If a silent period of more than 1.5 character intervals occurs before completion of the frame, the receiving device flushes the incomplete message and assumes that the next byte is the address field of a new message. Similarly, if a new message begins before 3.5 character intervals after a previous message, the receiving device considers it a continuation of the previous message. This behavior causes a timeout (no response from the slave), since the value in the final CRC field is not valid for the combined messages.

3.8.4 Address Field

The address field of a message frame contains 8 bits. Valid slave device addresses are in the range of 0–247 decimal. The individual slave devices are assigned addresses in the range of 1–247. (0 is reserved for broadcast mode, which all slaves recognize.) A master addresses a slave by placing the slave address in the address field of the message. When the slave sends its response, it places its own address in this address field to let the master know which slave is responding.

3.8.5 Function Field

The function field of a message frame contains 8 bits. Valid codes are in the range of 1–FF. Function fields are used to send messages between master and slave. When a message is sent from a master to a slave device, the function code field tells the slave what kind of action to

perform. When the slave responds to the master, it uses the function code field to indicate either a normal (error-free) response, or that some kind of error occurred (called an exception response).

For a normal response, the slave simply echoes the original function code. For an exception response, the slave returns a code that is equivalent to the original function code with its most significant bit set to logic 1. In addition, the slave places a unique code into the data field of the response message. This code tells the master what kind of error occurred, or the reason for the exception. Also refer to *chapter 3.8.12 Function Codes Supported by Modbus RTU* and *chapter 3.8.13 Modbus Exception Codes*.

3.8.6 Data Field

The data field is constructed using sets of 2 hexadecimal digits, in the range of 00 to FF hexadecimal. These digits are made up of 1 RTU character. The data field of messages sent from a master to a slave device contains additional information which the slave must use to act according to the function code. The information can include items such as coil or register addresses, the quantity of items to be handled, and the count of actual data bytes in the field.

3.8.7 CRC Check Field

Messages include an error-checking field, operating based on a cyclic redundancy check (CRC) method. The CRC field checks the contents of the entire message. It is applied regardless of any parity check method used for the individual characters of the message. The CRC value is calculated by the transmitting device, which appends the CRC as the last field in the message. The receiving device recalculates a CRC during receipt of the message and compares the calculated value to the actual value received in the CRC field. If the 2 values are unequal, a bus timeout results. The error-checking field contains a 16-bit binary value implemented as 2 8-bit bytes. After the implementation, the low-order byte of the field is appended first, followed by the high-order byte. The CRC high-order byte is the last byte sent in the message.

3.8.8 Coil Register Addressing

For coil register addressing, refer to *Modbus RTU Operating Instructions*.

3.8.9 Access via PCD Write/Read

The advantage of using the PCD write/read configuration is that the controller can write or read more data in one telegram. Up to 63 registers can be read or written to via

the function code read holding register or write multiple registers in 1 telegram. The structure is also flexible so that only 2 registers can be written to, and 10 registers can be read from the controller.

The PCD write list is data sent from the controller to the frequency converter such as:

- Control word.
- Reference.
- Application dependent data like minimum reference and ramp times.

NOTICE

The control word and reference is always sent in the list from the controller to the frequency converter.

The PCD write list is set up in *parameter 8-42 PCD Write Configuration*.

The PCD read list is data sent from the frequency converter to the controller such as:

- Status word.
- Main actual value.
- Application-dependent data like running hours, motor current, and alarm word.

NOTICE

The status word and main actual value are always sent in the list from the frequency converter to the controller.

Write		Read	
Master → Frequency Converter		Frequency Converter → Master	
Holding Register	Controlled by Parameter	Holding Register	Controlled by Parameter
2810	CTW 8-42 [0]	2910	STW 8-43 [0]
2811	REF 8-42 [1]	2911	MAV 8-43 [1]
2812	PCD 2 write 8-42 [2]	2912	PCD 2 read 8-43 [2]
2813	PCD 3 write 8-42 [3]	2913	PCD 3 read 8-43 [3]
2814	PCD 4 write 8-42 [4]	2914	PCD 4 read 8-43 [4]
2815	PCD 5 write 8-42 [5]	2915	PCD 5 read 8-43 [5]
...	... write read ...
2873	PCD 63 write 8-42 [63]	2919	PCD 63 read 8-43 [63]

Illustration 3.15 PCD Write/Read Lists

NOTICE

The boxes marked in gray are not changeable, they are the default values.

NOTICE

Map 32-bit parameters inside the 32-bit boundaries, PCD2 & PCD3 or PCD4 & PCD5, and so on, where the parameter number is mapped twice to *parameter 8-42 PCD Write Configuration* or *parameter 8-43 PCD Read Configuration*.

3.8.10 Mapping the Holding Registers to Drive Parameters

Example:

The PLC sends control word, reference, set the analog output 42 and set the torque limit.

Frequency Converter → Drive				
Register	2810	2811	2812	2813
Write	CTW	REF	Analog output 42	Torque limit

CTW = Parameter 16-85, REF = Parameter 16-86, Analog output = Parameter 6-52, Torque limit Motor mode = 4-16

Illustration 3.16 PLC Sending Data

Example:

The frequency converter sends status word, main actual value, actual motor current, digital inputs, and torque [Nm].

Frequency Converter → Master					
Register	2910	2911	2912	2913	2914
Read	STW	MAV	Motor current	Digital inputs	Actual Torque [Nm]

STW = Parameter 16-03, MAV = Parameter 16-05, Motor Current = Parameter 16-14, Digital Inputs = Parameter 16-60, Actual Torque [Nm]

Illustration 3.17 Frequency Converter Sending Data

Example, continued

Map the input and output data of the Modbus RTU to the parameter of the frequency converter. Use *parameter 8-42 PCD Write Configuration* and *parameter 8-43 PCD Read Configuration* for the mapping.

842.0	PCD write configuration	FC Port CTW 1
842.1	PCD write configuration	FC Port REF 1
842.2	PCD write configuration	Terminal 42 Output B...
842.3	PCD write configuration	Torque Limit Motor M...
842.4	PCD write configuration	None

1308C198.10

Illustration 3.18 Mapping Input/Output Data in Parameter 8-42 PCD Write Configuration

NOTICE

Gray lines are fixed, red are user-selectable.

Set up the following parameters in the frequency converter:

843.0	PCD read configuration	Status Word
843.1	PCD read configuration	Main Actual Value [%]
843.2	PCD read configuration	Motor Current
843.3	PCD read configuration	Digital Input
843.4	PCD read configuration	Torque [Nm]
843.5	PCD read configuration	None

1308C199.10

Illustration 3.19 Mapping Input/Output Data in Parameter 8-43 PCD Read Configuration

NOTICE

The motor current in parameter 16-14 Motor current is 32 bit. This mapping is only mapping the lower 16 bit, so the maximum motor current readout is 327 A.

For higher Amp readout, use 32-bit readout.

Mapping a 32-bit parameter as 16 bit always accesses the 16 lower bits.

3.8.11 How to Control the Frequency Converter

This section describes codes which can be used in the function and data fields of a Modbus RTU message.

3.8.12 Function Codes Supported by Modbus RTU

Modbus RTU supports use of the following function codes in the function field of a message.

Function	Function code
Read coils	1 hex
Read holding registers	3 hex
Write single coil	5 hex
Write single register	6 hex
Write multiple coils	F hex
Write multiple registers	10 hex
Get comm. event counter	B hex
Report slave ID	11 hex
Read write multiple registers	17 hex

Table 3.15 Function Codes

Function	Function code	Subfunction code	Subfunction
Diagnostics	8	1	Restart communication.
		2	Return diagnostic register.
		10	Clear counters and diagnostic register.
		11	Return bus message count.
		12	Return bus communication error count.
		13	Return slave error count.
		14	Return slave message count.

Table 3.16 Function Codes

3.8.13 Modbus Exception Codes

For a full explanation of the structure of an exception code response, refer to chapter 3.8.5 Function Field.

Code	Name	Meaning
1	Illegal function	The function code received in the query is not an allowable action for the server (or slave). This may be because the function code is only applicable to newer devices, and was not implemented in the unit selected. It could also indicate that the server (or slave) is in the wrong state to process a request of this type, for example because it is not configured and is being asked to return register values.
2	Illegal data address	The data address received in the query is not an allowable address for the server (or slave). More specifically, the combination of reference number and transfer length is invalid. For a controller with 100 registers, a request with offset 96 and length 4 would succeed, a request with offset 96 and length 5 generates exception 02.

Code	Name	Meaning
3	Illegal data value	A value contained in the query data field is not an allowable value for server (or slave). This indicates a fault in the structure of the remainder of a complex request, such as that the implied length is incorrect. It specifically does NOT mean that a data item submitted for storage in a register has a value outside the expectation of the application program, since the Modbus protocol is unaware of the significance of any particular value of any particular register.
4	Slave device failure	An unrecoverable error occurred while the server (or slave) was attempting to perform the requested action.

Table 3.17 Modbus Exception Codes

3.9 How to Access Parameters

3.9.1 Parameter Handling

The PNU (parameter number) is translated from the register address contained in the Modbus read or write message. The parameter number is translated to Modbus as (10 x parameter number) *decimal*. Example: Reading *parameter 3-12 Catch up/slow Down Value* (16 bit): The holding register 3120 holds the parameters value. A value of 1352 (*decimal*), means that the parameter is set to 12.52%

Reading *parameter 3-14 Preset Relative Reference* (32 bit): The holding registers 3410 and 3411 hold the parameters values. A value of 11300 (*decimal*), means that the parameter is set to 1113.00.

For information on the parameters, size, and conversion index, see *chapter 4 Parameters*.

3.9.2 Storage of Data

The coil 65 decimal determines whether data written to the frequency converter is stored in EEPROM and RAM (coil 65=1) or only in RAM (coil 65= 0).

3.9.3 IND (Index)

Some parameters in the frequency converter are array parameters, for example *parameter 3-10 Preset Reference*. Since the Modbus does not support arrays in the holding registers, the frequency converter has reserved the holding register 9 as pointer to the array. Before reading or writing an array parameter, set the holding register 9. Setting holding register to the value of 2 causes all following read/write to array parameters to be to the index 2.

3.9.4 Text Blocks

Parameters stored as text strings are accessed in the same way as the other parameters. The maximum text block size is 20 characters. If a read request for a parameter is for more characters than the parameter stores, the response is truncated. If the read request for a parameter is for fewer characters than the parameter stores, the response is space filled.

3.9.5 Conversion Factor

A parameter value can only be transferred as a whole number. To transfer decimals, use a conversion factor.

3.9.6 Parameter Values

Standard data types

Standard data types are int 16, int 32, uint 8, uint 16, and uint 32. They are stored as 4x registers (40001–4FFFF). The parameters are read using function 03 hex *read holding registers*. Parameters are written using the function 6 hex *preset single register* for 1 register (16 bits), and the function 10 hex *preset multiple registers* for 2 registers (32 bits). Readable sizes range from 1 register (16 bits) up to 10 registers (20 characters).

Non-standard data types

Non-standard data types are text strings and are stored as 4x registers (40001–4FFFF). The parameters are read using function 03 hex *read holding registers* and written using function 10 hex *preset multiple registers*. Readable sizes range from 1 register (2 characters) up to 10 registers (20 characters).

3.10 Examples

The following examples show various Modbus RTU commands.

3.10.1 Read Holding Registers (03 hex)

Description

This function reads the contents of holding registers in the slave.

Query

The query message specifies the starting register and quantity of registers to be read. Register addresses start at 0, that is, registers 1–4 are addressed as 0–3.

Example: Read *parameter 3-03 Maximum Reference*, register 03030.

Field name	Example (hex)
Slave address	01
Function	03 (Read holding registers)
Starting address HI	0B (Register address 3029)
Starting address LO	D5 (Register address 3029)
Number of points HI	00
Number of points LO	02 – (<i>parameter 3-03 Maximum Reference is 32 bits long, that is, 2 registers</i>)
Error check (CRC)	–

Table 3.18 Query

Response

The register data in the response message is packed as 2 bytes per register, with the binary contents right justified within each byte. For each register, the 1st byte contains the high-order bits, and the 2nd contains the low-order bits.

Example: hex 000088B8=35.000=35 Hz.

Field name	Example (hex)
Slave address	01
Function	03
Byte count	04
Data HI (register 3030)	00
Data LO (register 3030)	16
Data HI (register 3031)	E3
Data LO (register 3031)	60
Error check (CRC)	–

Table 3.19 Response

3.10.2 Preset Single Register (06 hex)

Description

This function presets a value into a single holding register.

Query

The query message specifies the register reference to be preset. Register addresses start at 0, that is, register 1 is addressed as 0.

Example: Write to *parameter 1-00 Configuration Mode*, register 1000.

Field name	Example (hex)
Slave address	01
Function	06
Register address HI	03 (Register address 999)
Register address LO	E7 (Register address 999)
Preset data HI	00
Preset data LO	01
Error check (CRC)	–

Table 3.20 Query

Response

The normal response is an echo of the query, returned after the register contents have been passed.

Field name	Example (hex)
Slave address	01
Function	06
Register address HI	03
Register address LO	E7
Preset data HI	00
Preset data LO	01
Error check (CRC)	–

Table 3.21 Response

3.10.3 Preset Multiple Registers (10 hex)

Description

This function presets values into a sequence of holding registers.

Query

The query message specifies the register references to be preset. Register addresses start at 0, that is, register 1 is addressed as 0. Example of a request to preset 2 registers (set *parameter 1-24 Motor Current* to 738 (7.38 A)):

Field name	Example (hex)
Slave address	01
Function	10
Starting address HI	04
Starting address LO	07
Number of registers HI	00
Number of registers LO	02
Byte count	04
Write data HI (Register 4: 1049)	00
Write data LO (Register 4: 1049)	00
Write data HI (Register 4: 1050)	02
Write data LO (Register 4: 1050)	E2
Error check (CRC)	–

Table 3.22 Query

Response

The normal response returns the slave address, function code, starting address, and quantity of registers preset.

Field name	Example (hex)
Slave address	01
Function	10
Starting address HI	04
Starting address LO	19
Number of registers HI	00
Number of registers LO	02
Error check (CRC)	-

Table 3.23 Response

3.10.4 Read/Write Multiple registers (17 hex)

Description

This function code combines 1 read operation and 1 write operation in a single Modbus transaction. The write operation is performed before the read.

Query

The query message specifies the starting address and number of holding registers to be read as well as the starting address, number of holding registers, and the data to be written. Holding registers are addressed starting at 0. Example of a request to set *parameter 1-24 Motor Current* to 738 (7.38 A) and read *parameter 3-03 Maximum Reference* which has value 50000 (50000 Hz):

Field name	Example (hex)
Follower Address	01
Function	17
Read Starting Address HI	0B (Register address 3029)
Read Starting Address LO	D5 (Register address 3029)
Quantity to Read HI	00
Quantity to Read LO	02 <i>(parameter 3-03 Maximum Reference is 32 bits long, that is, 2 registers)</i>
Write Starting Address HI	04 (Register address 1239)
Write Starting address LO	D7 (Register address 1239)
Quantity to Write HI	00
Quantity to Write LO	02
Write Byte Count	04
Write Registers Value HI	00
Write Registers Value LO	00
Write Registers Value HI	02
Write Registers Value LO	0E
Error Check (CRC)	-

Table 3.24 Query

Response

The normal response contains the data from the group of registers that were read. The byte count field specifies the quantity of bytes to follow in the read data field.

Field name	Example (hex)
Follower Address	01
Function	17
Byte Count	04
Read Registers Value HI	00
Read Registers Value LO	00
Read Registers Value HI	C3
Read Registers Value LO	50
CRC	-

Table 3.25 Response

3.11 FC Control Profile

3.11.1 Control Word According to FC Profile (8–10 Protocol = FC profile)

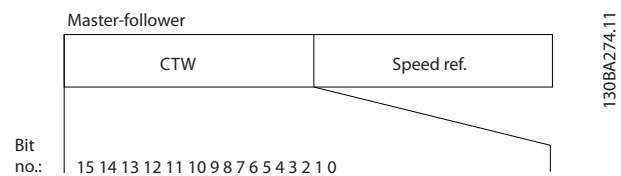

Illustration 3.20 Control Word According to FC Profile

Bit	Bit value=0	Bit value=1
00	Reference value	External selection lsb
01	Reference value	External selection msb
02	DC brake	Ramp
03	Coasting	No coasting
04	Quick stop	Ramp
05	Hold output frequency	Use ramp
06	Ramp stop	Start
07	No function	Reset
08	No function	Jog
09	Ramp 1	Ramp 2
10	Data invalid	Data valid
11	Relay 01 open	Relay 01 active
12	Relay 02 open	Relay 02 active
13	Parameter set-up	Selection lsb
15	No function	Reverse

Table 3.26 Control Word According to FC Profile

Explanation of the control bits

Bits 00/01

Bits 00 and 01 are used to select among the 4 reference values, which are pre-programmed in *parameter 3-10 Preset Reference* according to *Table 3.27*.

Programmed reference value	Parameter	Bit 01	Bit 00
1	Parameter 3-10 Preset Reference [0]	0	0
2	Parameter 3-10 Preset Reference [1]	0	1
3	Parameter 3-10 Preset Reference [2]	1	0
4	Parameter 3-10 Preset Reference [3]	1	1

Table 3.27 Control Bits

NOTICE

Make a selection in *parameter 8-56 Preset Reference Select* to define how bit 00/01 gates with the corresponding function on the digital inputs.

Bit 02, DC brake

Bit 02=0: Leads to DC braking and stop. Set braking current and duration in *parameter 2-01 DC Brake Current* and *parameter 2-02 DC Braking Time*.

Bit 02=1: Leads to ramping.

Bit 03, Coasting

Bit 03=0: The frequency converter immediately releases the motor (the output transistors are shut off) and it coasts to a standstill.

Bit 03=1: If the other starting conditions are met, the frequency converter starts the motor.

Make a selection in *parameter 8-50 Coasting Select* to define how bit 03 gates with the corresponding function on a digital input.

Bit 04, Quick stop

Bit 04=0: Makes the motor speed ramp down to stop (set in *parameter 3-81 Quick Stop Ramp Time*).

Bit 05, Hold output frequency

Bit 05=0: The present output frequency (in Hz) freezes. Change the frozen output frequency only with the digital inputs (*parameter 5-10 Terminal 18 Digital Input* to *parameter 5-13 Terminal 29 Digital Input*) programmed to [21] Speed up and [22] Speed down.

NOTICE

If freeze output is active, the frequency converter can only be stopped by 1 of the following:

- Bit 03 Coasting stop.
- Bit 02 DC braking.
- Digital input (*parameter 5-10 Terminal 18 Digital Input* to *parameter 5-13 Terminal 29 Digital Input*) programmed to [5] DC braking, [2] Coasting stop, or [3] Reset and coasting stop.

Bit 06, Ramp stop/start

Bit 06=0: Causes a stop and makes the motor speed ramp-down to stop via the selected ramp down parameter.

Bit 06=1: Allows the frequency converter to start the motor if the other starting conditions are met.

Make a selection in *parameter 8-53 Start Select* to define how bit 06 ramp stop/start gates with the corresponding function on a digital input.

Bit 07, Reset

Bit 07=0: No reset.

Bit 07=1: Resets a trip. Reset is activated on the leading signal edge, that is, when changing from logic 0 to logic 1.

Bit 08, Jog

Bit 08=1: *Parameter 3-11 Jog Speed [Hz]* determines the output frequency.

Bit 09, Selection of ramp 1/2

Bit 09=0: Ramp 1 is active (*parameter 3-41 Ramp 1 Ramp Up Time* to *parameter 3-42 Ramp 1 Ramp Down Time*).

Bit 09=1: Ramp 2 (*parameter 3-51 Ramp 2 Ramp Up Time* to *parameter 3-52 Ramp 2 Ramp Down Time*) is active.

Bit 10, Data not valid/Data valid

Tell the frequency converter whether to use or ignore the control word.

Bit 10=0: The control word is ignored.

Bit 10=1: The control word is used. This function is relevant because the telegram always contains the control word, regardless of the telegram type. If the control word is not needed when updating or reading parameter, turn it off.

Bit 11, Relay 01

Bit 11=0: Relay not activated.

Bit 11=1: Relay 01 activated if [36] Control word bit 11 is selected in *parameter 5-40 Function Relay*.

Bit 12, Relay 02

Bit 12=0: Relay 02 is not activated.

Bit 12=1: Relay 02 is activated if [37] Control word bit 12 is selected in *parameter 5-40 Function Relay*.

Bit 13, Selection of set-up

Use bit 13 to select from the 2 menu set-ups according to Table 3.28.

Set-up	Bit 13
1	0
2	1

Table 3.28 Menu Set-ups

The function is only possible when [9] Multi set-ups is selected in *parameter 0-10 Active Set-up*.

Use *parameter 8-55 Set-up Select* to define how bit 13 gates with the corresponding function on the digital inputs.

Bit 15 Reverse

Bit 15=0: No reversing.

Bit 15=1: Reversing. In the default setting, reversing is set to digital in *parameter 8-54 Reversing Select*. Bit 15 causes reversing only when serial communication, [2] Logic OR or [3] Logic AND is selected.

3.11.2 Status Word According to FC Profile (STW) (parameter 8-30 Protocol = FC profile)

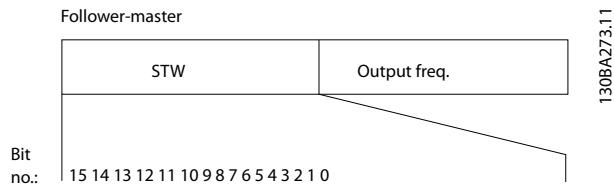

Illustration 3.21 Status Word

Bit	Bit=0	Bit=1
00	Control not ready	Control ready
01	Drive not ready	Drive ready
02	Coasting	Enable
03	No error	Trip
04	No error	Error (no trip)
05	Reserved	-
06	No error	Triplock
07	No warning	Warning
08	Speed≠reference	Speed=reference
09	Local operation	Bus control
10	Out of frequency limit	Frequency limit OK
11	No operation	In operation
12	Drive OK	Stopped, auto start
13	Voltage OK	Voltage exceeded
14	Torque OK	Torque exceeded
15	Timer OK	Timer exceeded

Table 3.29 Status Word According to FC Profile

Explanation of the status bits

Bit 00, Control not ready/ready

Bit 00=0: The frequency converter trips.
 Bit 00=1: The frequency converter controls are ready but the power component does not necessarily receive any supply (if there is 24 V external supply to controls).

Bit 01, Drive ready

Bit 01=0: The frequency converter is not ready.
 Bit 01=1: The frequency converter is ready for operation but the coasting command is active via the digital inputs or via serial communication.

Bit 02, Coasting stop

Bit 02=0: The frequency converter releases the motor.
 Bit 02=1: The frequency converter starts the motor with a start command.

Bit 03, No error/trip

Bit 03=0: The frequency converter is not in fault mode. Bit 03=1: The frequency converter trips. To re-establish operation, press [Reset].

Bit 04, No error/error (no trip)

Bit 04=0: The frequency converter is not in fault mode.
 Bit 04=1: The frequency converter shows an error but does not trip.

Bit 05, Not used

Bit 05 is not used in the status word.

Bit 06, No error/triplock

Bit 06=0: The frequency converter is not in fault mode.
 Bit 06=1: The frequency converter is tripped and locked.

Bit 07, No warning/warning

Bit 07=0: There are no warnings.
 Bit 07=1: A warning has occurred.

Bit 08, Speed reference/speed=reference

Bit 08=0: The motor runs but the present speed is different from the preset speed reference. It might, for example, be the case when the speed ramps up/down during start/stop.
 Bit 08=1: The motor speed matches the preset speed reference.

Bit 09, Local operation/bus control

Bit 09=0: [Off/Reset] is activated on the control unit or [2] Local in parameter 3-13 Reference Site is selected. It is not possible to control the frequency converter via serial communication.
 Bit 09=1: It is possible to control the frequency converter via the fieldbus/serial communication.

Bit 10, Out of frequency limit

Bit 10=0: The output frequency has reached the value in parameter 4-12 Motor Speed Low Limit [Hz] or parameter 4-14 Motor Speed High Limit [Hz].
 Bit 10=1: The output frequency is within the defined limits.

Bit 11, No operation/in operation

Bit 11=0: The motor is not running.
 Bit 11=1: The frequency converter has a start signal without coast.

Bit 12, Drive OK/stopped, autostart

Bit 12=0: There is no temporary overtemperature on the frequency converter.
 Bit 12=1: The frequency converter stops because of overtemperature but the unit does not trip and resumes operation once the overtemperature normalizes.

Bit 13, Voltage OK/limit exceeded

Bit 13=0: There are no voltage warnings.
 Bit 13=1: The DC voltage in the frequency converter's DC link is too low or too high.

Bit 14, Torque OK/limit exceeded

Bit 14=0: The motor current is lower than the current limit selected in parameter 4-18 Current Limit.
 Bit 14=1: The current limit in parameter 4-18 Current Limit is exceeded.

Bit 15, Timer OK/limit exceeded

Bit 15=0: The timers for motor thermal protection and thermal protection are not exceeded 100%.
 Bit 15=1: One of the timers exceeds 100%.

3.11.3 Bus Speed Reference Value

Speed reference value is transmitted to the frequency converter in a relative value in %. The value is transmitted in the form of a 16-bit word; in integers (0–32767) the value 16384 (4000 hex) corresponds to 100%. Negative figures are formatted by 2's complement. The actual output frequency (MAV) is scaled in the same way as the bus reference.

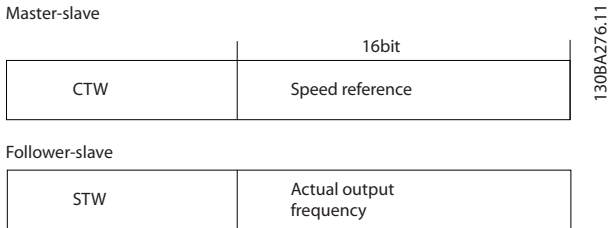

Illustration 3.22 Actual Output Frequency (MAV)

The reference and MAV are scaled as follows:

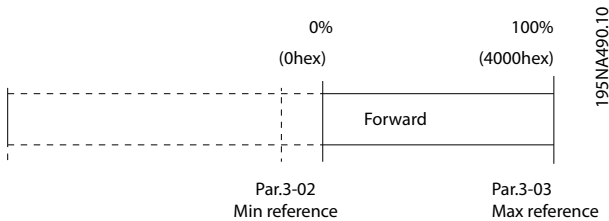

Illustration 3.23 Reference

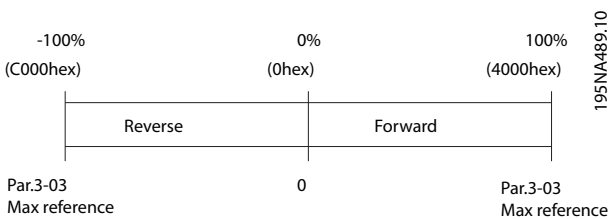

Illustration 3.24 MAV when Parameter 1-00 Configuration Mode is set to [0] Open Loop

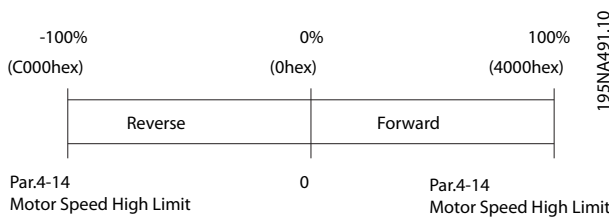

Illustration 3.25 MAV when Parameter 1-00 Configuration Mode is set to [3] Closed Loop

4 Parameters

4.1 Main Menu - Operation and Display - Group 0

Parameters related to the fundamental functions of the frequency converter, function of the LCP keys, and configuration of the LCP display.

4.1.1 0-0* Basic Settings

0-01 Language	
Option:	Function:
	Defines the language to be used in the display.
[0] *	English
[1]	Deutsch
[2]	Francais
[3]	Dansk
[4]	Spanish
[5]	Italiano
[28]	Bras.port
[255]	No Text

0-03 Regional Settings	
Option:	Function:
	<p>NOTICE</p> <p>This parameter cannot be adjusted while the motor runs.</p> <p>To meet the needs for different default settings in different parts of the world, <i>parameter 0-03 Regional Settings</i> is implemented in the frequency converter. The selected setting influences the default setting of the motor nominal frequency.</p>
[0] *	International Sets the default value of <i>parameter 1-23 Motor Frequency</i> to 50 Hz.
[1]	North America Sets the default value of <i>parameter 1-23 Motor Frequency</i> to 60 Hz.

0-04 Operating State at Power-up	
Option:	Function:
	Select the operating mode after reconnection of the frequency converter to mains voltage after power-down when operating in <i>Hand (local) mode</i> .
[0] *	Resume Resumes operation of the frequency converter, maintaining the same local reference and the same start/stop condition (applied by [Hand On]/[Off] on the LCP or local start via a digital input as before the frequency converter was powered down.

0-04 Operating State at Power-up	
Option:	Function:
[1]	<p>Forced stop, ref=old</p> <p>Uses saved reference [1] to stop the frequency converter, but at the same time retains the local speed reference in memory before powering down. After mains voltage is reconnected, and after receiving a start command (pressing [Hand On] key or using the local start command via a digital input), the frequency converter restarts and operates at the retained speed reference.</p>

0-06 GridType	
Option:	Function:
	<p>Select the grid type of the supply voltage/frequency.</p> <p>NOTICE</p> <p>Not all options are supported in all power sizes.</p> <p>IT grid is a supply mains, where there are no connections to ground. Adjust the position of the RFI switch to match the grid type (refer to <i>VLT® DriveMotor FCP 106/FCM 106 Operating Instructions</i>).</p> <p>Delta is a supply mains where the secondary part of the transformer is delta connected, and 1 phase is connected to ground.</p>
[10]	380-440V/ 50Hz/IT-grid
[11]	380-440V/50Hz/ Delta
[12]	380-440V/50Hz
[20]	440-480V/ 50Hz/IT-grid
[21]	440-480V/50Hz/ Delta
[22]	440-480V/50Hz
[110]	380-440V/ 60Hz/IT-grid
[111]	380-440V/60Hz/ Delta
[112]	380-440V/60Hz
[120]	440-480V/ 60Hz/IT-grid
[121]	440-480V/60Hz/ Delta
[122]	440-480V/60Hz

0-07 Auto DC Braking		
Option:	Function:	
		Protective function against overvoltage at coast.
		NOTICE Can cause PWM when coasted.
[0]	Off	This function is not active.
[1] *	On	This function is active.

4.1.2 0-1* Define and Set-up Operations

A complete set of all parameters controlling the frequency converter is called a set-up. The frequency converter contains 2 set-ups: Set-up 1 and set-up 2. Furthermore, a fixed set of factory settings can be copied into 1 or both set-ups.

Some of the advantages of having more than 1 set-up in the frequency converter are:

- Run the motor in 1 set-up (active set-up) while updating parameters in another set-up (edit set-up).
- Connect the 2 motors (1 at a time) to the frequency converter. Motor data for the 2 motors can be placed in the 2 set-ups.
- Rapidly change settings of the frequency converter and/or the motor while the motor runs. For example, ramp time or preset references via bus or digital inputs.

The active set-up can be set as multi set-up, where the active set-up is selected via input on a digital input terminal and/or via the bus control word.

To copy set-up 1 to set-up 2, or copy set-up 2 to set-up 1, use *parameter 0-51 Set-up Copy*. To avoid conflicting settings of the same parameter within 2 different set-ups, link the set-ups using *parameter 0-12 Link Setups*. Stop the frequency converter before switching between set-ups where parameters marked *not changeable during operation* have different values.

Parameters that are *not changeable during operation* are marked *false* in *chapter 6 Parameter Lists*.

0-10 Active Set-up		
Option:	Function:	
		Select the set-up in which the frequency converter operates.
[1] *	Set-up 1	Set-up 1 is active.
[2]	Set-up 2	Set-up 2 is active.
[9]	Multi Set-up	Used for remote set-up selections via digital inputs and the serial communication port. This

0-10 Active Set-up		
Option:	Function:	
		set-up uses the settings from <i>parameter 0-12 Link Setups</i> .

0-11 Programming Set-up		
Option:	Function:	
		The number of the set-up being edited is shown in the LCP, flashing.
[1]	Set-up 1	Edit set-up 1
[2]	Set-up 2	Edit set-up 2
[9] *	Active Set-up	Edit parameters in the set-up selected via digital I/Os.

0-12 Link Setups		
Option:	Function:	
		If the set-ups are not linked, a change between them is not possible while the motor runs.
[0]	Not linked	When selecting a different set-up for operation, the set-up change does not occur until the motor is coasted.
[20] *	Linked	Copies <i>not changeable during operation</i> parameters from 1 set-up to the other. It is possible to switch set-ups while the motor runs.

0-20 Display Line 1.1 Small		
Option:	Function:	
		Select a variable for display in line 1, left position.
[0]		No display value selected.
[37]	Display Text 1	Enables an individual text string to be written, for showing in the LCP or to be read via serial communication.
[38]	Display Text 2	Enables an individual text string to be written, for showing in the LCP or to be read via serial communication.
[39]	Display Text 3	Enables an individual text string to be written, for showing in the LCP or to be read via serial communication.
[953]	Profibus Warning Word	Shows PROFIBUS communication warnings.
[1501]	Running Hours	View the number of running hours of the motor.
[1502]	kWh Counter	View the mains power consumption in kWh.
[1600]	Control Word	View the Control Word sent from the frequency converter via the serial communication port in hex code.

0-20 Display Line 1.1 Small		
Option:	Function:	
[1601]	Reference [Unit]	Total reference (sum of digital/analog/preset/bus/freeze ref./catch up and slow down) in selected unit.
[1602]	Reference [%]	Total reference (sum of digital/analog/preset/bus/freeze ref./catch up and slow down) in percent.
[1603]	Status Word	Present status word.
[1605]	Main Actual Value [%]	View the 2-byte word sent with the status word to the bus master reporting the main actual value.
[1609]	Custom Readout	View the user-defined readouts as defined in <i>parameter 0-30 Custom Readout Unit</i> , <i>parameter 0-31 Custom Readout Min Value</i> , and <i>parameter 0-32 Custom Readout Max Value</i> .
[1610]	Power [kW]	Actual power consumed by the motor in kW.
[1611]	Power [hp]	Actual power consumed by the motor in hp.
[1612]	Motor Voltage	Voltage supplied to the motor.
[1613]	Frequency	Motor frequency, that is, the output frequency from the frequency converter in Hz.
[1614]	Motor current	Phase current of the motor measured as effective value.
[1615]	Frequency [%]	Motor frequency, that is, the output frequency from the frequency converter in percent.
[1616]	Torque [Nm]	Present motor load as a percentage of the rated motor torque.
[1618]	Motor Thermal	Thermal load on the motor, calculated by the ETR function. See also parameter group 1-9* Motor Temperature.
[1622]	Torque [%]	Shows the actual torque produced, in percentage.
[1626]	Power Filtered [kW]	
[1627]	Power Filtered [hp]	
[1630]	DC Link Voltage	DC-link voltage in the frequency converter.
[1634]	Heatsink Temp.	Present heat sink temperature of the frequency converter. The cut-out limit is 95 ± 5 °C; cutting back in occurs at 70 ± 5 °C.
[1635]	Inverter Thermal	Percentage load of the inverters.

0-20 Display Line 1.1 Small		
Option:	Function:	
[1636]	Inv. Nom. Current	Nominal current of the frequency converter.
[1637]	Inv. Max. Current	Maximum current of the frequency converter.
[1638]	SL Controller State	State of the event executed by the control.
[1639]	Control Card Temp.	Temperature of the control card.
[1650]	External Reference	Sum of the external reference as a percentage, that is, the sum of analog/pulse/bus.
[1652]	Feedback[Unit]	Reference value from programmed digital inputs.
[1660]	Digital Input	Shows the status of the digital inputs. Signal low = 0; Signal high = 1. Regarding order, see <i>parameter 16-60 Digital Input</i> . Bit 0 is at the extreme right.
[1661]	Terminal 53 Setting	Setting of input terminal 53. Current = 0; Voltage = 1.
[1662]	Analog Input AI53	Actual value at input 53 either as a reference or protection value.
[1663]	Terminal 54 Setting	Setting of input terminal 54. Current = 0; Voltage = 1.
[1664]	Analog Input AI54	Actual value at input 54 either as reference or protection value.
[1665]	Analog Output AO42 [mA]	Actual value at output 42 in mA. Use <i>parameter 6-50 Terminal 42 Output</i> to select the variable to be represented by output 42.
[1666]	Digital Output	Binary value of all digital outputs.
[1667]	Pulse Input #29 [Hz]	Actual value of the frequency applied at terminal 29 as a pulse input.
[1671]	Relay Output [bin]	View the setting of all relays.
[1672]	Counter A	View the present value of Counter A.
[1673]	Counter B	View the present value of Counter B.
[1679]	Analog Output AO45	
[1680]	Fieldbus CTW 1	Control word (CTW) received from the Bus Master.
[1682]	Fieldbus REF 1	Main reference value sent with control word via the serial communications network for example, from the BMS, PLC, or other master controller.
[1684]	Comm. Option STW	Extended fieldbus communication option status word.

0-20 Display Line 1.1 Small		
Option:	Function:	
[1685]	FC Port CTW 1	Control word (CTW) received from the Bus Master.
[1686]	FC Port REF 1	Status word (STW) sent to the Bus Master.
[1690]	Alarm Word	One or more alarms in a hex code (used for serial communications).
[1691]	Alarm Word 2	One or more alarms in a hex code (used for serial communications).
[1692]	Warning Word	One or more warnings in a hex code (used for serial communications).
[1693]	Warning Word 2	One or more warnings in a hex code (used for serial communications).
[1694]	Ext. Status Word	One or more status conditions in a hex code (used for serial communications).
[1695]	Ext. Status Word 2	One or more status conditions in a hex code (used for serial communications).
[1697]	Alarm Word 3	
[1850]	Sensorless Readout [unit]	

0-21 Display Line 1.2 Small

Select a variable for display in line 1, middle position.

Option:	Function:	
[1614] *	Motor Current	The options are the same as those listed in <i>parameter 0-20 Display Line 1.1 Small</i> .

0-22 Display Line 1.3 Small

Select a variable for display in line 1, right position.

Option:	Function:	
[1610] *	Power [kW]	The options are the same as those listed in <i>parameter 0-20 Display Line 1.1 Small</i> .

0-23 Display Line 2 Large

Select a variable for display in line 2.

Option:	Function:	
[1613] *	Frequency	The options are the same as those listed in <i>parameter 0-20 Display Line 1.1 Small</i> .

0-24 Display Line 3 Large

Select a variable for display in line 3.

4.1.3 0-3* LCP Custom Readout and Display Text

It is possible to customize the display elements for various purposes.

Custom readout

The calculated value to be shown is based on settings in *parameter 0-30 Custom Readout Unit*, *parameter 0-31 Custom Readout Min Value* (linear only), *parameter 0-32 Custom Readout Max Value*, *parameter 4-14 Motor Speed High Limit [Hz]*, and actual speed.

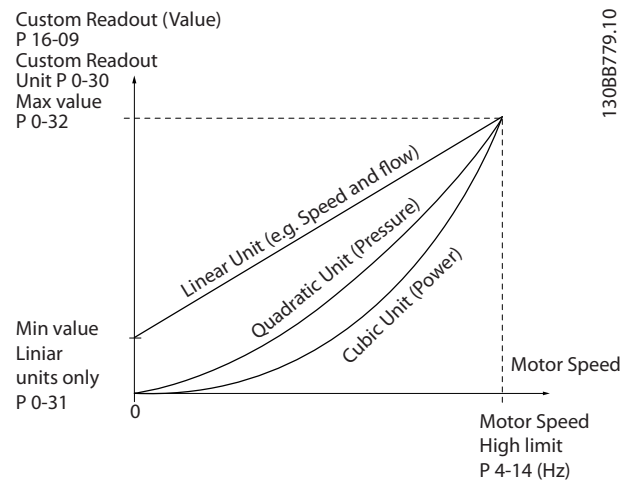

Illustration 4.1 Custom Readout

The relation depends on the type of unit selected in *parameter 0-30 Custom Readout Unit*:

Unit type	Speed relation
Dimensionless	Linear
Speed	
Flow, volume	
Flow, mass	
Velocity	
Length	
Temperature	Quadratic
Pressure	
Power	Cubic

Table 4.1 Speed Relation

0-30 Custom Readout Unit	
Option:	Function:
	Program a value to be shown in the display of the LCP. The value has a linear, squared, or cubed relation to speed. This relation depends on the unit selected (see <i>Table 4.1</i>). The actual calculated value can

0-30 Custom Readout Unit		
Option:	Function:	
		be read in <i>parameter 16-09 Custom Readout</i> .
[0]	None	
[1] *	%	
[5]	PPM	
[10]	l/Min	
[11]	RPM	
[12]	Pulse/s	
[20]	l/s	
[21]	l/min	
[22]	l/h	
[23]	m ³ /s	
[24]	m ³ /min	
[25]	m ³ /h	
[30]	kg/s	
[31]	kg/min	
[32]	kg/h	
[33]	t/min	
[34]	t/h	
[40]	m/s	
[41]	m/min	
[45]	m	
[60]	Degree Celsius	
[70]	mbar	
[71]	bar	
[72]	Pa	
[73]	kPa	
[74]	m Wg	
[80]	kW	
[120]	GPM	
[121]	gal/s	
[122]	gal/min	
[123]	gal/h	
[124]	CFM	
[127]	ft ³ /h	
[140]	ft/s	
[141]	ft/min	
[160]	Degree Fahr	
[170]	psi	
[171]	lb/in ²	
[172]	in WG	
[173]	ft WG	
[180]	hp	

0-31 Custom Readout Min Value		
Range:	Function:	
0 CustomReadoutUnit*	[0 - 999999.99 CustomReadoutUnit]	This parameter sets the minimum value of the custom-defined readout (occurs at 0 speed). It is only possible to select a value different from 0 when selecting a linear unit in

0-31 Custom Readout Min Value		
Range:	Function:	
		<i>parameter 0-30 Custom Readout Unit</i> . For quadratic and cubic units, the minimum value is 0.

0-32 Custom Readout Max Value		
Range:	Function:	
100 CustomReadoutUnit*	[0.0 - 999999.99 CustomReadoutUnit]	This parameter sets the maximum value to be shown when the speed of the motor has reached the set value for <i>parameter 4-14 Motor Speed High Limit [Hz]</i> .

0-37 Display Text 1		
Range:	Function:	
[0 - 0]		Use this parameter to write an individual text string to be read via serial communication. Device ID can be included. Only used when running BACnet.

0-38 Display Text 2		
Range:	Function:	
[0 - 0]		Use this parameter to write an individual text string to be read via serial communication. Only used when running BACnet.

0-39 Display Text 3		
Range:	Function:	
[0 - 0]		Use this parameter to write an individual text string to be read via serial communication. Only used when running BACnet.

4.1.4 0-4* LCP

Enable, disable, and password protect individual keys on the LCP.

0-40 [Hand on] Key on LCP		
Option:	Function:	
[0]	Disabled	To avoid unintended start of the frequency converter in <i>local mode</i> , select [0] <i>Disabled</i> .
[1] *	Enabled	[Hand On] is enabled.

0-42 [Auto on] Key on LCP		
Option:	Function:	
[0]	Disabled	To avoid unintended start of the frequency converter from the LCP, select [0] <i>Disabled</i> .
[1] *	Enabled	[Auto On] is enabled.

0-44 [Off/Reset] Key on LCP		
Option:	Function:	
[0]	Disabled	Disable the off/reset key.
[1] *	Enabled	Enable both off and reset functions.
[7]	Enable Reset Only	Enable the reset function, and disable the off function to avoid unintended stop of the frequency converter.

4.1.5 0-5* Copy/Save

Copy parameter settings between set-ups and to/from the LCP.

0-50 LCP Copy		
Option:	Function:	
[0] *	No copy	
[1]	All to LCP	Copies all parameters in all set-ups from the frequency converter memory to the LCP memory. For service purposes, copy all parameters to the LCP after commissioning.
[2]	All from LCP	Copies all parameters in all set-ups from the LCP memory to the frequency converter memory.
[3]	Size indep. from LCP	Copies only the parameters that are independent of the motor size. The latter selection can be used to program several frequency converters with the same function without disturbing motor data that is already set.
[10]	Delete LCP copy data	

0-51 Set-up Copy		
Option:	Function:	
[0] *	No copy	No function
[1]	Copy from setup 1	Copy from set-up 1 to set-up 2.
[2]	Copy from setup 2	Copy from set-up 2 to set-up 1.
[9]	Copy from Factory setup	Copy factory setting to programming set-up (selected in <i>parameter 0-11 Programming Set-up</i>).

4.1.6 0-6* Password

0-60 Main Menu Password		
Range:	Function:	
0*	[0 - 999]	Define the password for access to the <i>Main Menu</i> via the [Main Menu] key. Setting the value to 0 disables the password function.

4.2 Main Menu - Load and Motor - Group 1

Parameters related to the motor nameplate load compensations and application load type.

4.2.1 1-0* General Settings

1-00 Configuration Mode		
Option:	Function:	
		NOTICE This parameter cannot be adjusted when the motor runs.
[0] *	Open Loop	Motor speed is determined by applying a speed reference or by setting the wanted speed when in local mode. Open loop is also used if the frequency converter is part of a closed-loop control system based on an external PI controller providing a speed reference signal as output.
[3]	Closed Loop	NOTICE When set for <i>Closed Loop</i> , the commands <i>Reversing</i> and <i>Start Reversing</i> do not reverse the direction of the motor. A reference from the built-in PI controller determines the motor speed. The built-in PI controller varies the motor speed as of a closed-loop control process (for example, constant pressure or flow). Configure the PI controller in parameter group 20-** <i>Drive Closed Loop</i> .
1-01 Motor Control Principle		
Option:	Function:	
[0]	U/f	NOTICE When running U/f, control slip and load compensations are not included. Used for parallel-connected motors and/or special motor applications. Set the U/f settings in parameter 1-55 <i>U/f Characteristic - U</i> and parameter 1-56 <i>U/f Characteristic - F</i> .
[1] *	VVC+	NOTICE When parameter 1-10 <i>Motor Construction</i> is set to PM-enabled options, only VVC+ option is available. Normal running mode, including slip and load compensations.

1-03 Torque Characteristics		
Option:	Function:	
[0]	Constant torque	For speed control of PM motors only.
[1] *	Variable Torque	For speed control of centrifugal pumps and fans. Also to be used when controlling more than 1 motor from the same frequency converter (for example, multiple condenser fans or cooling tower fans). Provides a voltage that is optimized for a squared torque load characteristic of the motor.
[3]	Auto Energy Optim.	For optimum energy efficient speed control of centrifugal pumps and fans, it provides a voltage optimized for a squared torque load characteristic of the motor. In addition, the AEO feature adapts the voltage exactly to the current load situation, by that reducing energy consumption and audible noise from the motor.

1-06 Clockwise Direction		
Option:	Function:	
		NOTICE This parameter cannot be adjusted while the motor runs. This parameter defines the term <i>clockwise</i> corresponding to the LCP direction arrow. Used for easy change of direction of shaft rotation without swapping motor wires.
[0] *	Normal	The motor shaft turns in clockwise direction when frequency converter is connected U→U; V→V; and W→W to motor.
[1]	Inverse	The motor shaft turns in counterclockwise direction when frequency converter is connected U→U; V→V; and W→W to motor.

1-08 Motor Control Bandwidth		
Option:	Function:	
[0]	High	High dynamic response.
[1]	Medium	Optimized for smooth steady-state operation.
[2]	Low	Optimized for smooth steady-state operation with lowest dynamic response.
[3]	Adaptive 1	Optimized for smooth steady-state operation, with extra active damping.
[4]	Adaptive 2	Alternative to Adaptive1, with focus on low-inductance PM motors.

4.2.2 1-10 to 1-12 Motor Selection

NOTICE

This parameter group cannot be adjusted while the motor runs.

The following parameters are active (x) depending on the setting of *parameter 1-10 Motor Construction*.

Parameter 1-10 Motor Construction	[0] Asynchron	[1] PM Motor non-salient
Parameter 1-00 Configuration Mode	x	x
Parameter 1-03 Torque Characteristics	x	
Parameter 1-06 Clockwise Direction	x	x
Parameter 1-14 Damping Gain		x
Parameter 1-15 Low Speed Filter Time Const.		x
Parameter 1-16 High Speed Filter Time Const.		x
Parameter 1-17 Voltage filter time const.		x
Parameter 1-20 Motor Power [kW]	x	
Parameter 1-22 Motor Voltage	x	
Parameter 1-23 Motor Frequency	x	x
Parameter 1-24 Motor Current	x	x
Parameter 1-25 Motor Nominal Speed	x	x
Parameter 1-26 Motor Cont. Rated Torque		x
Parameter 1-29 Automatic Motor Adaption (AMA)	x	x
Parameter 1-30 Stator Resistance (Rs)	x	x
Parameter 1-33 Stator Leakage Reactance (X1)	x	
Parameter 1-35 Main Reactance (Xh)	x	
Parameter 1-37 d-axis Inductance (Ld)		x
Parameter 1-39 Motor Poles	x	x
Parameter 1-40 Back EMF at 1000 RPM		x
Parameter 1-52 Min Speed Normal Magnetising [Hz]	x	
Parameter 1-60 Low Speed Load Compensation	x	
Parameter 1-61 High Speed Load Compensation	x	
Parameter 1-62 Slip Compensation	x	
Parameter 1-63 Slip Compensation Time Constant	x	
Parameter 1-64 Resonance Dampening	x	
Parameter 1-65 Resonance Dampening Time Constant	x	
Parameter 1-66 Min. Current at Low Speed		x
Parameter 1-71 Start Delay	x	x
Parameter 1-72 Start Function	x	x
Parameter 1-73 Flying Start	x	x

Parameter 1-80 Function at Stop	x	x
Parameter 1-82 Min Speed for Function at Stop [Hz]	x	x
Parameter 1-90 Motor Thermal Protection	x	x
Parameter 2-00 DC Hold Current	x	
Parameter 2-01 DC Brake Current	x	
Parameter 2-02 DC Braking Time	x	
Parameter 2-04 DC Brake Cut In Speed [Hz]	x	
Parameter 2-06 Parking Current		x
Parameter 2-07 Parking Time		x
Parameter 2-10 Brake Function	x	x
Parameter 2-16 AC brake Max. Current	x	
Parameter 2-17 Over-voltage Control	x	x
Parameter 4-10 Motor Speed Direction	x	x
Parameter 4-12 Motor Speed Low Limit [Hz]	x	x
Parameter 4-14 Motor Speed High Limit [Hz]	x	x
Parameter 4-18 Current Limit	x	x
Parameter 4-19 Max Output Frequency	x	x
Parameter 4-58 Missing Motor Phase Function	x	x
Parameter 14-40 VT Level	x	
Parameter 14-41 AEO Minimum Magnetisation	x	
Parameter 30-22 Locked Rotor Detection		x
Parameter 30-23 Locked Rotor Detection Time [s]		x

Table 4.2 Parameters Activated by Setting of Parameter 1-10 Motor Construction

1-10 Motor Construction		
Option:	Function:	
[0] *	Asynchron	For asynchronous motors.
[1]	PM, non salient SPM, non Sat	For permanent magnet (PM) motors with surface-mounted (non-salient) magnets. Refer to <i>parameter 1-14 Damping Gain</i> to <i>parameter 1-17 Voltage filter time const.</i> for details about optimizing the motor operation.
[2]	PM, salient IPM, non Sat	For permanent magnet (PM) motors with interior (salient) magnets, without inductance saturation control.
[3]	PM, salient IPM, Sat	For permanent magnet (PM) motors with interior (salient) magnets, with inductance saturation control.

1-11 Motor Selection		
Option:	Function:	
[0] *	Default Motor Selection	Automatically sets the manufacturer's settings for the selected motor.

1-11 Motor Selection		
Option:	Function:	
		Setting the parameter value might change these parameters. Other parameters also change, when changing motor type selection.
[1]	Motor Selection 1	
[2]	Motor Selection 2	
[3]	Motor Selection 3	
[4]	Motor Selection 4	
[5]	Motor Selection 5	
[6]	Motor Selection 6	
[7]	Motor Selection 7	
[8]	Motor Selection 8	
[9]	Motor Selection 9	
[10]	Motor Selection 10	
[11]	Motor Selection 11	
[12]	Motor Selection 12	
[13]	Motor Selection 13	
[14]	Motor Selection 14	
[15]	Motor Selection 15	
[16]	Motor Selection 16	
[17]	Motor Selection 17	
[18]	Motor Selection 18	
[19]	Motor Selection 19	
[20]	Motor Selection 20	
[21]	Motor Selection 21	
[22]	Motor Selection 22	
[23]	Motor Selection 23	
[24]	Motor Selection 24	
[25]	Motor Selection 25	
[26]	Motor Selection 26	
[27]	Motor Selection 27	
[28]	Motor Selection 28	
[29]	Motor Selection 29	
[30]	Motor Selection 30	
[31]	Motor Selection 31	
[32]	Motor Selection 32	
[33]	Motor Selection 33	
[34]	Motor Selection 34	
[35]	Motor Selection 35	
[36]	Motor Selection 36	
[37]	Motor Selection 37	
[38]	Motor Selection 38	
[39]	Motor Selection 39	
[40]	Motor Selection 40	
[41]	Motor Selection 41	
[42]	Motor Selection 42	
[43]	Motor Selection 43	
[44]	Motor Selection 44	
[45]	Motor Selection 45	
[46]	Motor Selection 46	
[47]	Motor Selection 47	
[48]	Motor Selection 48	

1-11 Motor Selection		
Option:	Function:	
[49]	Motor Selection 49	
[50]	Motor Selection 50	
[51]	Motor Selection 51	
[52]	Motor Selection 52	
[53]	Motor Selection 53	
[54]	Motor Selection 54	
[55]	Motor Selection 55	
[56]	Motor Selection 56	
[57]	Motor Selection 57	
[58]	Motor Selection 58	
[59]	Motor Selection 59	
[60]	Motor Selection 60	
[61]	Motor Selection 61	
[62]	Motor Selection 62	
[63]	Motor Selection 63	
[64]	Motor Selection 64	

1-12 Motor ID		
Range:	Function:	
Default Motor*	[0 - 0]	Shows motor name according to the selected motor in <i>parameter 1-11 Motor Selection</i> .

4.2.3 1-14 to 1-17 VVC⁺ PM

The default control parameters for VVC⁺ PM motor control core are optimized for HVAC applications and inertia load in the range of $50 > J_l/J_m > 5$. J_l is load inertia from the application and J_m is machine inertia.

For low inertia applications ($J_l/J_m < 5$), it is recommended that *parameter 1-17 Voltage filter time const.* is increased with a factor of 5–10. Sometimes, *parameter 14-08 Damping Gain Factor* should also be reduced to improve performance and stability.

For high inertia applications ($J_l/J_m > 50$), it is recommended that *parameter 1-15 Low Speed Filter Time Const.*, *parameter 1-16 High Speed Filter Time Const.*, and *parameter 14-08 Damping Gain Factor* are increased to improve performance and stability.

For high load at low speed (<30% of rated speed), it is recommended that *parameter 1-17 Voltage filter time const.* is increased due to non-linearity in the inverter at low speed.

1-14 Damping Gain		
Range:	Function:	
120 %*	[0 - 250 %]	The parameter stabilizes the PM motor to ensure smooth and stable operation. The value of damping gain controls the dynamic performance of the PM motor. Low damping gain results in high dynamic performance and a high value results in a low dynamic performance. The dynamic performance is related to the motor data

1-14 Damping Gain		
Range:		Function:
		and load type. If the damping gain is too high or low, the control becomes unstable.

1-15 Low Speed Filter Time Const.		
Range:		Function:
Size related*	[0.01 - 20 s]	High-pass filter damping time constant determines the response time to load steps. Obtain quick control through a short damping time constant. However, if this value is too short, the control becomes unstable. This time constant is used below 10% rated speed.

1-16 High Speed Filter Time Const.		
Range:		Function:
Size related*	[0.01 - 20 s]	High-pass filter damping time constant determines the response time to load steps. Obtain quick control through a short damping time constant. However, if this value is too short, the control becomes unstable. This time constant is used above 10% rated speed.

1-17 Voltage filter time const.		
Range:		Function:
Size related*	[0.001 - 1 s]	Machine supply voltage filter time constant is used for reducing the influence of high frequency ripples and system resonances in the calculation of machine supply voltage. Without this filter, the ripples in the currents can distort the calculated voltage and affects the stability of the system.

4.2.4 1-2* Motor Data

This parameter group comprises input data from the nameplate on the connected motor.

NOTICE

Changing the value of these parameters affects the setting of other parameters.

1-20 Motor Power		
Enter the nominal motor power in kW/hp according to the motor nameplate data. The default value corresponds to the nominal rated output of the unit.		
This parameter cannot be adjusted while the motor runs.		
Option:		Function:
[3]	0.18 kW - 0.25 hp	
[4]	0.25 kW - 0.33 hp	
[5]	0.37 kW - 0.5 hp	

1-20 Motor Power		
Enter the nominal motor power in kW/hp according to the motor nameplate data. The default value corresponds to the nominal rated output of the unit.		
This parameter cannot be adjusted while the motor runs.		
Option:		Function:
[6]	0.55 kW - 0.75 hp	
[7]	0.75 kW - 1 hp	
[8]	1.1 kW - 1 hp	
[9]	1.5 kW - 2 hp	
[10]	2.2 kW - 3 hp	
[11]	3 kW - 4 hp	
[12]	3.7 kW - 5 hp	
[13]	4 kW - 5.4 hp	
[14]	5.5 kW - 7.5 hp	
[15]	7.5 kW - 10 hp	
[16]	11 kW - 15 hp	
[17]	15 kW - 20 hp	
[18]	18.5 kW - 25 hp	
[19]	22 kW - 30 hp	
[20]	30 kW - 40 hp	

1-22 Motor Voltage		
Range:		Function:
Size related*	[50 - 1000 V]	Enter the nominal motor voltage according to the motor nameplate data. The default value corresponds to the nominal rated output of the unit.

1-23 Motor Frequency		
Range:		Function:
Size related*	[20 - 400 Hz]	<p>NOTICE</p> <p>This parameter cannot be adjusted while the motor runs.</p> <p>Select the motor frequency value from the motor nameplate data. For 87 Hz operation with 230/400 V motors, set the nameplate data for 230 V/50 Hz. Adapt <i>parameter 4-14 Motor Speed High Limit [Hz]</i> and <i>parameter 3-03 Maximum Reference</i> to the 87 Hz application.</p>

1-24 Motor Current		
Range:		Function:
Size related*	[0.01 - 10000.00 A]	<p>NOTICE</p> <p>This parameter cannot be adjusted while the motor runs.</p> <p>Enter the nominal motor current value from the motor nameplate data. This data is used for calculating motor torque, motor thermal protection, and so on.</p>

1-25 Motor Nominal Speed		
Range:		Function:
Size related*	[50 - 60000 RPM]	Enter the nominal motor speed value from the motor nameplate data. This data is used for calculating automatic motor compensations.

1-26 Motor Cont. Rated Torque		
Range:		Function:
Size related*	[0.1 - 10000 Nm]	<p>NOTICE Changing this parameter affects settings of other parameters.</p> <p>This parameter is available only when parameter 1-10 Motor Construction is set to options that enable permanent motor mode.</p>

1-29 Automatic Motor Adaption (AMA)		
Option:		Function:
		<p>NOTICE This parameter cannot be adjusted while the motor runs.</p> <p>The AMA function optimizes dynamic motor performance by automatically optimizing the advanced motor parameter 1-30 Stator Resistance (Rs) to parameter 1-35 Main Reactance (Xh) while the motor is stationary.</p>
[0]	Off	No function
[1]	Enable Complete AMA	<p>If parameter 1-10 Motor Construction is set to [0] Asynchron, performs AMA of parameter 1-30 Stator Resistance (Rs), parameter 1-33 Stator Leakage Reactance (X1), and parameter 1-35 Main Reactance (Xh). If parameter 1-10 Motor Construction is set to options that enable PM motor, performs AMA of parameter 1-30 Stator Resistance (Rs), and parameter 1-35 Main Reactance (Xh).</p> <p>NOTICE Terminal 27 Digital Input (parameter 5-12 Terminal 27 Digital Input) has [2] Coast inverse as the default setting. This means that AMA cannot be performed if there is no 24 V to terminal 27.</p>
[2]	Enable Reduced AMA	Performs a reduced AMA of the stator resistance R_s in the system only. Select this option if an LC filter is used between the frequency converter and the motor.

NOTICE

When parameter 1-10 Motor Construction is set to options that enable permanent motor mode, the only option available is [1] Enable Complete AMA.

Activate the AMA function by pressing [Hand On] after selecting [1] Enable Complete AMA or [2] Enable Reduced AMA. After a normal sequence, the display reads: Press [OK] to finish AMA. After pressing [OK], the frequency converter is ready for operation.

NOTICE

- For the best adaptation of the frequency converter, run AMA on a cold motor.
- AMA cannot be performed while the motor runs.
- AMA cannot be performed on a motor with a bigger power rating than the frequency converter, for example when a 5.5 kW (7.5 hp) motor is connected to a 4 kW (5 hp) frequency converter.

NOTICE

Avoid generating external torque during AMA.

NOTICE

If 1 of the settings in parameter group 1-2* Motor Data is changed, the advanced motor parameters, parameter 1-30 Stator Resistance (Rs) to parameter 1-39 Motor Poles return to default setting.

NOTICE

Run full AMA without filter only, but run reduced AMA with a filter.

1-30 Stator Resistance (Rs)		
Range:		Function:
Size related*	[0.0 - 99.99 Ohm]	<p>NOTICE This parameter cannot be adjusted while the motor runs.</p> <p>Set the stator resistance value. Enter the value from a motor datasheet or perform an AMA on a cold motor.</p>

1-33 Stator Leakage Reactance (X1)		
Range:		Function:
Size related*	[0.0 - 999.9 Ohm]	Set stator leakage reactance of motor.

1-35 Main Reactance (Xh)		
Range:		Function:
Size related*	[0.0 - 999.9 Ohm]	Set the main reactance of the motor using 1 of these methods: <ul style="list-style-type: none"> Run an AMA on a cold motor. The frequency converter measures the value from the motor. Enter the X_h value manually. Obtain the value from the motor supplier. Use the X_h default setting. The frequency converter establishes the setting based on the motor nameplate data.

1-37 d-axis Inductance (Ld)		
Range:		Function:
Size related*	[0 - 1000 mH]	<p>NOTICE This parameter is only active when parameter 1-10 Motor Construction is set to [1] PM, non-salient SPM.</p> <p>Enter the value of the d-axis inductance. Obtain the value from the PM motor datasheet.</p>

For asynchronous motor, stator resistance, and d-axis inductance values are normally, described in technical specifications as between line and common (startpoint). For PM motors, they are typically described in technical specifications as between line-line. PM motors are typically built for star connection.

Parameter 1-30 Stator Resistance (Rs) (line to common).	This parameter gives stator winding resistance (R _s) similar to asynchronous motor stator resistance. The stator resistance is defined for line-to-common measurement. For line-line data, where stator resistance is measured between any 2 lines, divide by 2.
Parameter 1-37 d-axis Inductance (Ld) (line to common).	This parameter gives direct axis inductance of the PM motor. The d-axis inductance is defined for phase-to-common measurement. For line-line data, where stator resistance is measured between any 2 lines, divide by 2.
Parameter 1-40 Back EMF at 1000 RPM (line to line value).	This parameter gives back EMF across stator terminal of PM motor at 1000 RPM mechanical speed specifically. It is defined between line-to-line and expressed in RMS value.

Table 4.3 Parameters Related to PM Motors

NOTICE

Motor manufacturers provide values for stator resistance (parameter 1-30 Stator Resistance (Rs)) and d-axis inductance (parameter 1-37 d-axis Inductance (Ld)) in technical specifications as between line and common (startpoint) or line between line. There is no general standard. The different set-ups of stator winding resistance and induction are shown in Illustration 4.2. Danfoss frequency converters always require the line-to-common value. The back EMF of a PM motor is defined as induced EMF developed across any of 2 phases of stator winding of a free-running motor. Danfoss frequency converters always require the line-to-line RMS value measured at 1000 RPM, mechanical speed of rotation. This is shown in Illustration 4.3).

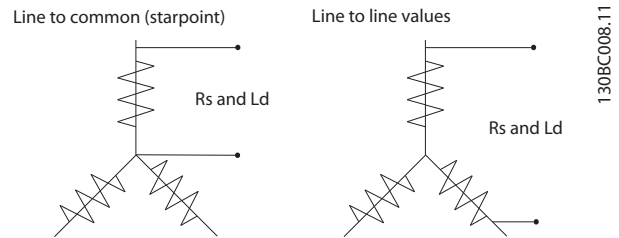

Illustration 4.2 Stator Winding Set-ups

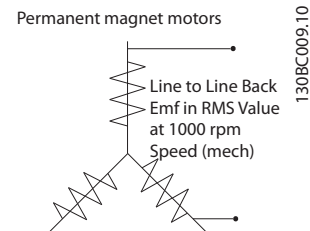

Illustration 4.3 Machine Parameter Definitions of Back EMF of PM Motors

1-38 q-axis Inductance (Lq)		
Range:		Function:
Size related*	[0.000 - 1000 mH]	Set the value of the q-axis inductance. Obtain the value from the permanent magnet motor datasheet. The value cannot be changed when the motor is running.

1-39 Motor Poles		
Range:		Function:
Size related*	[2 - 100]	<p>NOTICE This parameter cannot be adjusted while the motor runs.</p> <p>Enter the number of motor poles.</p>

1-39 Motor Poles		
Range:	Function:	
		The motor pole value is always an even number, because it refers to the total pole numbers, not pairs of poles.

1-40 Back EMF at 1000 RPM		
Range:	Function:	
Size related*	[10 - 9000 V]	Line-line RMS back EMF voltage at 1000 RPM.

1-44 d-axis Inductance Sat. (LdSat)		
Range:	Function:	
Size related*	[0 - 1000 mH]	This parameter corresponds to the inductance saturation of Ld. Ideally, this parameter has the same value as <i>parameter 1-37 d-axis Inductance (Ld)</i> . If the motor supplier provides an induction curve, enter the induction value at 200% of the nominal value.

1-45 q-axis Inductance Sat. (LqSat)		
Range:	Function:	
Size related*	[0 - 1000 mH]	This parameter corresponds to the inductance saturation of Lq. Ideally, this parameter has the same value as <i>parameter 1-38 q-axis Inductance (Lq)</i> . If the motor supplier provides an induction curve, enter the induction value at 200% of the nominal value.

1-46 Position Detection Gain		
Range:	Function:	
100 %*	[20 - 200 %]	Adjusts the amplitude of the test pulse during position detection at start. Adjust this parameter to improve the position measurement.

1-48 Current at Min Inductance for d-axis		
Range:	Function:	
100 %*	[20 - 200 %]	This parameter specifies the saturation curve of the d-inductance values. From 20–100% of this parameter, the inductances are linearly approximated due to <i>parameter 1-37 d-axis Inductance (Ld)</i> , <i>parameter 1-38 q-axis Inductance (Lq)</i> , <i>parameter 1-44 d-axis Inductance Sat. (LdSat)</i> , and <i>parameter 1-45 q-axis Inductance Sat. (LqSat)</i> . Below and above they are specified by the corresponding parameters. Parameters are related to the motor nameplate load compensations, the application load type, and the electronic brake function for quick stop/hold of the motor.

1-49 Current at Min Inductance for q-axis		
Range:	Function:	
100 %*	[20 - 200 %]	This parameter specifies the saturation curve of the q-inductance values. From 20–100% of this parameter, the inductances are linearly approximated due to <i>parameter 1-37 d-axis Inductance (Ld)</i> , <i>parameter 1-38 q-axis Inductance (Lq)</i> , <i>parameter 1-44 d-axis Inductance Sat. (LdSat)</i> , and <i>parameter 1-45 q-axis Inductance Sat. (LqSat)</i> . Below and above they are specified by the corresponding parameters. Parameters are related to the motor nameplate load compensations, the application load type, and the electronic brake function for quick stop/hold of the motor.

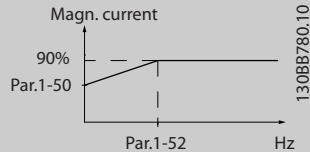
1-50 Motor Magnetisation at Zero Speed		
Range:	Function:	
100 %*	[0 - 300 %]	Use this parameter along with <i>parameter 1-52 Min Speed Normal Magnetising [Hz]</i> to obtain a different thermal load on the motor when running at low speed. Enter a value that is a percentage of the rated magnetizing current. If the setting is too low, the torque on the motor shaft may be reduced.
		
Illustration 4.4 Motor Magnetization		

1-52 Min Speed Normal Magnetising [Hz]		
Range:	Function:	
1 Hz*	[0.1 - 10.0 Hz]	Set the required frequency for normal magnetizing current. Use this parameter along with <i>parameter 1-50 Motor Magnetisation at Zero Speed</i> . See <i>Illustration 4.4</i> .

1-55 U/f Characteristic - U		
Range:	Function:	
Size related*	[0 - 1000 V]	Enter voltage at each frequency point to form a U/f characteristic matching the motor. Frequency points are defined in <i>parameter 1-56 U/f Characteristic - F</i> .

1-56 U/f Characteristic - F		
Range:	Function:	
Size related* [0 - 400.0 Hz]	Enter frequency points to form a U/f characteristic matching the motor. Voltage at each point is defined in <i>parameter 1-55 U/f Characteristic - U</i> .	
	Make a U/f characteristic based on 6 definable voltages and frequencies, see <i>Illustration 4.5</i> . Simplify U/f characteristics by merging 2 or more points (voltages and frequencies). Set the points at equal values.	
	Illustration 4.5 U/f Characteristic	

1-60 Low Speed Load Compensation		
Range:	Function:	
100 %* [0 - 300 %]	Enter the low speed load voltage compensation value in percent. This parameter is used for optimizing the low speed load performance. This parameter is only active if <i>parameter 1-10 Motor Construction = [0] Asynchron</i> .	

1-61 High Speed Load Compensation		
Range:	Function:	
100 %* [0 - 300 %]	Enter the high-speed load voltage compensation value in percent. This parameter is used for optimizing the high-speed load performance. This parameter is only active if <i>parameter 1-10 Motor Construction = [0] Asynchron</i> .	

1-62 Slip Compensation		
Range:	Function:	
Size related* [-400 - 400 %]	Enter the % value for slip compensation to compensate for tolerances in the value of $n_{M,N}$. Slip compensation is calculated automatically, which is based on the nominal motor speed $n_{M,N}$.	

1-63 Slip Compensation Time Constant		
Range:	Function:	
0.1 s* [0.05 - 5 s]	Enter the slip compensation reaction speed. A high value results in slow reaction, and a low value results in quick reaction. If low-	

1-63 Slip Compensation Time Constant		
Range:	Function:	
	frequency resonance problems occur, use a longer time setting.	

1-64 Resonance Dampening		
Range:	Function:	
100 %* [0 - 500 %]	Enter the resonance damping value. Set <i>parameter 1-64 Resonance Dampening</i> and <i>parameter 1-65 Resonance Dampening Time Constant</i> to help eliminate high-frequency resonance problems. To reduce resonance oscillation, increase the value of <i>parameter 1-64 Resonance Dampening</i> .	

1-65 Resonance Dampening Time Constant		
Range:	Function:	
0.005 s* [0.001 - 0.050 s]	Set <i>parameter 1-64 Resonance Dampening</i> and <i>parameter 1-65 Resonance Dampening Time Constant</i> to help eliminate high-frequency resonance problems. Enter the time constant that provides the best dampening.	

1-66 Min. Current at Low Speed		
Range:	Function:	
50 %* [0 - 120 %]	Applies to PM motors only. Increasing the minimum current improves motor torque at low speed, but also reduces efficiency.	

1-70 PM Start Mode		
This parameter is valid for software version 2.80 and later versions. Use this parameter to select the PM motor start mode, which is to initialize the VVC+ control core for previously free-running PM motors. This parameter is active for PM motors in VVC+ mode only if the motor is stopped (or running at low speed).		
Option:	Function:	
[0] *	Rotor Detection	The rotor detection function estimates the electrical angle of the rotor and uses the angle as a starting point. This option is the standard selection for automation frequency converter applications. If the flying start function detects that motor is running at low speed or is stopped, the frequency converter can detect the rotor position (the angle). The frequency converter then starts the motor from that angle.
[1]	Parking	The parking function applies DC current across the stator winding, and rotates the rotor to electrical zero position. This function is typically selected for HVAC applications. If the flying start function

1-70 PM Start Mode		
This parameter is valid for software version 2.80 and later versions. Use this parameter to select the PM motor start mode, which is to initialize the VVC+ control core for previously free-running PM motors. This parameter is active for PM motors in VVC+ mode only if the motor is stopped (or running at low speed).		
Option:	Function:	
	detects that motor is running at low speed or is stopped, the frequency converter sends out a DC current to park the motor at an angle. The frequency converter then starts the motor from that angle.	

1-71 Start Delay		
Range:	Function:	
0 s* [0 - 10 s]	This parameter enables a delay of the starting time. The frequency converter begins with the start function selected in <i>parameter 1-72 Start Function</i> . Set the start delay time until acceleration is to begin.	

1-72 Start Function		
Option:	Function:	
[0] DC Hold/delay time	The motor is energized with <i>parameter 2-00 DC Hold/Motor Preheat Current</i> during start delay time.	
[2] * Coast/delay time	The frequency converter is coasted during start delay time (frequency converter off).	

1-73 Flying Start		
Option:	Function:	
	This function makes it possible to catch a motor which is spinning freely due to a mains drop-out. Flying start searches in clockwise direction only. If not successful, a DC brake is activated. If PM motor is selected, Parking is carried out if the speed is below 2.5–5%, in the time set in <i>parameter 2-07 Parking Time</i> .	
[0] Disabled *	Select [0] Disabled if this function is not required.	
[2] Enabled Always	Select [2] Enabled always to enable the frequency converter to “catch” and control a spinning motor. The parameter is always set to [2] Enabled always when <i>parameter 1-10 Motor Construction</i> = [1] PM non-salient. Important related parameters: <ul style="list-style-type: none"> Parameter 2-01 DC Brake Current Parameter 2-06 Parking Current Parameter 2-07 Parking Time 	

The flying start function used for PM motors is based on an initial speed estimation. The speed is always estimated as the first thing after an active start signal is given.

If the speed estimate comes out below 2.5–5% of nominal speed, the parking function is engaged (see *parameter 2-06 Parking Current* and *parameter 2-07 Parking Time*). Otherwise, the frequency converter catches the motor at that speed and resumes normal operation.

Current limitations of the flying start principle used for PM motors:

- The speed range is up to 100% nominal speed or the field weakening speed (which ever is lowest).
- For high inertia applications (that is, where the load inertia is more than 30 times larger than the motor inertia).

1-80 Function at Stop		
Option:	Function:	
	Select this function after a stop command or after the speed is ramped down to the settings in <i>parameter 1-82 Min Speed for Function at Stop [Hz]</i> .	
[0] * Coast	Leaves the motor in free mode.	
[1] DC hold / Motor Preheat	Energizes the motor with a DC hold current (see <i>parameter 2-00 DC Hold/Motor Preheat Current</i>).	

1-82 Min Speed for Function at Stop [Hz]		
Range:	Function:	
0 Hz* [0 - 20 Hz]	Set the output frequency at which to activate <i>parameter 1-80 Function at Stop</i> .	

1-88 AC Brake Gain		
Range:	Function:	
1.4* [1.0 - 2.0]	Set AC brake power capability (set the ramp-down time when inertia is constant). If the DC-link voltage is not higher than DC-link voltage warning value, the generator torque can be adjusted with this function . The higher the AC-brake gain, the stronger the brake capability. If the brake gain equals to 1.0, there is no AC brake capability.	
NOTICE		
Continuous generator torque can lead to overheating of the motor due to high motor current. Protect the motor against overheating in <i>parameter 2-16 AC Brake, Max current</i> .		

1-90 Motor Thermal Protection		
Option:	Function:	
		Using ETR (electronic thermal relay), the motor temperature is calculated based on frequency, current, and time. If a thermistor is not present, Danfoss recommends using the ETR function. The functionality is the same for asynchronous motors and PM motors. NOTICE ETR calculation is based on motor data from parameter group 1-2* <i>Motor Data</i> .
[0]	No protection	Disables temperature monitoring.
[1]	Thermistor warning	A thermistor issues a warning if the upper limit of motor temperature range is exceeded.
[2]	Thermistor trip	If the upper limit of motor temperature range is exceeded, a thermistor gives an alarm and makes the frequency converter trip.
[3]	ETR warning 1	If the calculated upper limit of the motor temperature range is exceeded, a warning occurs.
[4]	ETR trip 1	If 90% of calculated upper limit of motor temperature range is exceeded, an alarm occurs and frequency converter trips.
[22]	ETR Trip - Extended Detection	Start motor thermal calculation based on the actual load and time as well as the motor frequency when the motor current is above 110% of the nominal motor current. Alternatively, start motor thermal calculation when the motor current is less than 110% of the nominal motor current, and the current limit is triggered.

1-93 Thermistor Source		
Option:	Function:	
		<i>Resource 1 to parameter 3-17 Reference Resource 3, parameter 20-00 Feedback 1 Source, parameter 20-03 Feedback 2 Source, parameter 24-06 Fire Mode Reference Source, and parameter 24-07 Fire Mode Feedback Source.</i>
[0]	None	Do not set thermistor source.
[1]	Analog input AI53	Use analog input 53 as thermistor source.
[6]	Digital input 29	Use digital input 29 as thermistor source.

1-93 Thermistor Source		
Option:	Function:	
		NOTICE This parameter cannot be adjusted while the motor is running. NOTICE Set the digital input to [0] PNP - Active at 24 V in parameter 5-03 Digital Input 29 Mode. Select the input at which the thermistor (PTC sensor) should be connected. When using an analog input, the same analog cannot be used as a reference in parameter 3-15 Reference

4.3 Main Menu - Brakes - Group 2

2-00 DC Hold/Motor Preheat Current		
Range:	Function:	
50 % *	[0 - 160 %]	<p>NOTICE The maximum value depends on the rated motor current. Avoid 100% current for too long. It may damage the motor due to overheating.</p> <p>Set holding current as a percentage of the rated motor current $I_{M,N}$ in <i>parameter 1-24 Motor Current</i>. <i>Parameter 2-00 DC Hold/Motor Preheat Current</i> holds the motor function (holding torque) or pre-heats the motor. This parameter is active if DC hold is selected in <i>parameter 1-72 Start Function</i> [0] or <i>parameter 1-80 Function at Stop</i> [1].</p>

2-01 DC Brake Current		
Range:	Function:	
50 % *	[0 - 150 %]	<p>NOTICE The maximum value depends on the rated motor current. Avoid 100% current for too long. It may damage the motor.</p> <p>Set current as % of rated motor current, <i>parameter 1-24 Motor Current</i>. DC-brake current is applied on stop command, when speed is below the limit set in <i>parameter 2-04 DC Brake Cut In Speed</i>; when the DC-brake inverse function is active (<i>parameters 5-1* Digital Inputs</i> are set to [5] <i>DC-brake inverse</i>; or via the serial port). See <i>parameter 2-02 DC Braking Time</i> for duration.</p>

2-02 DC Braking Time		
Range:	Function:	
10 s*	[0 - 60 s]	Set the duration of the DC-brake current set in <i>parameter 2-01 DC Brake Current</i> , once activated.

2-04 DC Brake Cut In Speed		
Range:	Function:	
0 Hz* [0 - 400 Hz]	This parameter is for setting the DC-brake cut-in speed at which <i>parameter 2-01 DC Brake Current</i> is to be active with a stop command.	

2-06 Parking Current		
Range:	Function:	
100 % *	[0 - 150 %]	Set current as percentage of rated motor current, <i>parameter 1-24 Motor Current</i> . Active with <i>parameter 1-73 Flying Start</i> . The parking current is active during the time period set in <i>parameter 2-07 Parking Time</i> .

2-06 Parking Current		
Range:	Function:	
		<p>NOTICE <i>Parameter 2-06 Parking Current</i> is only active when PM motor construction is selected in <i>parameter 1-10 Motor Construction</i></p>

2-07 Parking Time		
Range:	Function:	
3 s* [0.1 - 60 s]	Set the duration of the parking current time set in <i>parameter 2-06 Parking Current</i> . Active in connection with <i>parameter 1-73 Flying Start</i> .	
		<p>NOTICE <i>Parameter 2-07 Parking Time</i> is only active when [1] PM, non-salient SPM is selected in <i>parameter 1-10 Motor Construction</i>.</p>

4.3.1 2-1* Brake Energy Function

Parameter group for selecting dynamic brake parameters.

2-10 Brake Function		
Option:	Function:	
[0] *	Off	The brake resistor is not active.
[2]	AC brake	AC brake is active.

2-16 AC Brake, Max current		
Range:	Function:	
100 % *	[0 - 160 %]	To avoid overheating of motor windings, enter the maximum permissible current when using AC brake.

2-17 Over-voltage Control		
Option:	Function:	
		Enable OVC during ramp down to reduce the risk of frequency converter trip due to overvoltage on the DC link caused by generative power from load.
[0]	Disabled	No OVC required.
[1]	Enabled (not at stop)	Activates OVC when the frequency converter is not in the stop state.
[2] *	Enabled	Activates OVC.
		<p>NOTICE The ramp time is automatically adjusted to avoid tripping of the frequency converter.</p>

4.3.2 2-2* Mechanical Brake

Parameters for setting the speed and current of the mechanical brake.

2-20 Release Brake Current		
Range:	Function:	
0 A* A]	[0 - 100	Set the motor current for release of the mechanical brake, when a start condition is present. The upper limit is specified in <i>parameter 16-37 Inv. Max. Current.</i>

2-22 Activate Brake Speed [Hz]		
Range:	Function:	
0 Hz*	[0 - 400 Hz]	Set the motor frequency for activation of the mechanical brake, when a stop condition is present.

4.4 Main Menu - Reference/Ramps - Group 3

4.4.1 3-0* Reference Limits

Parameters for setting the reference unit, limits, and ranges.

Also see parameter group 20-0* Feedback for information on settings in closed loop.

3-02 Minimum Reference		
Range:	Function:	
0*	[-4999-4999]	The minimum reference is the lowest value obtainable by summing all references.

3-03 Maximum Reference		
Range:	Function:	
Size related*	[-4999.0 - 4999 ReferenceFeed-backUnit]	The maximum reference is the highest value obtainable by summing all references. The maximum reference unit matches the selection of configuration in parameter 1-00 Configuration Mode.

4.4.2 3-1* References

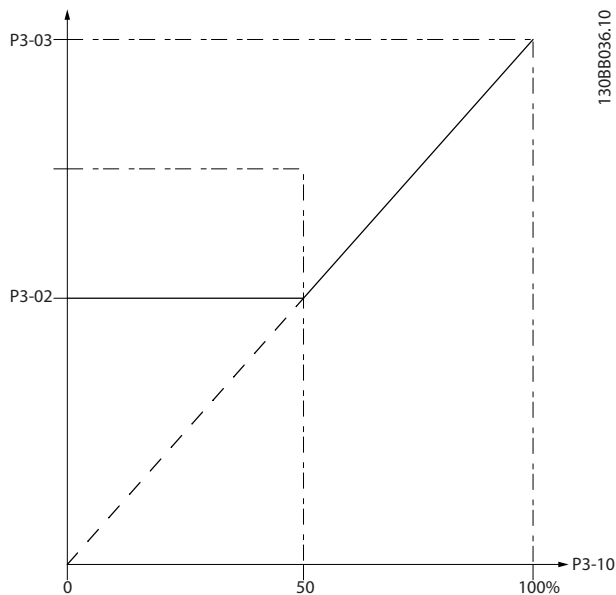

Illustration 4.6 References

3-10 Preset Reference		
Range:	Function:	
0 %*	[-100 - 100 %]	Enter up to 8 different preset references (0-7) in this parameter, using array programming. Select preset reference bit 0/1/2 [16], [17], or [18]

3-10 Preset Reference		
Range:	Function:	
		for the corresponding digital inputs in parameter group 5-1* Digital Inputs, for selecting dedicated references.

3-11 Jog Speed [Hz]		
Range:	Function:	
5 Hz*	[0 - 400.0 Hz]	The jog speed is a fixed output speed at which the frequency converter runs when the jog function is activated. See also parameter 3-80 Jog Ramp Time.

3-12 Catch up/slow Down Value		
Range:	Function:	
0 %*	[0 - 100 %]	Enter a percentage (relative) value to be either added to or deducted from the actual reference for catch up or slow down. If catch up is selected via 1 of the digital inputs (parameter 5-10 Terminal 18 Digital Input to parameter 5-15 Terminal 33 Digital Input), the percentage (relative) value is added to the total reference. If slow down is selected via 1 of the digital inputs (parameter 5-10 Terminal 18 Digital Input to parameter 5-15 Terminal 33 Digital Input), the percentage (relative) value is deducted from the total reference. Obtain extended functionality with the DigiPot function. See parameter group 3-9* Digital Potentiometer.

3-14 Preset Relative Reference		
Range:	Function:	
0 %*	[-100 - 100 %]	Define the fixed value in % to be added to the variable value defined in parameter 3-18 Relative Scaling Reference Resource, Relative Scaling Reference Source. The sum of fixed and variable values (labeled Y in Illustration 4.7) is multiplied by actual reference (labeled X in Illustration 4.7). This product is added to actual reference $X + X \times \frac{Y}{100}$

Illustration 4.7 Preset Relative Reference

3-15 Reference 1 Source		
Option:	Function:	
		Select the input to be used for the 1st reference signal. Parameter 3-15 Reference 1 Source, parameter 3-16 Reference 2 Source, and parameter 3-17 Reference 3 Source define up to 3 different reference signals.

3-15 Reference 1 Source		
Option:	Function:	
		The sum of these reference signals defines the actual reference.
[0]	No function	
[1] *	Analog Input 53	
[2]	Analog Input 54	
[7]	Pulse input 29	
[11]	Local bus reference	

3-16 Reference 2 Source		
Option:	Function:	
		Select the input to be used for the 2nd reference signal. <i>Parameter 3-15 Reference 1 Source, parameter 3-16 Reference 2 Source, and parameter 3-17 Reference 3 Source</i> define up to 3 different reference signals. The sum of these reference signals defines the actual reference. See also <i>parameter 1-93 Thermistor Source</i> .
[0]	No function	
[1]	Analog Input 53	
[2] *	Analog Input 54	
[7]	Pulse input 29	
[11]	Local bus reference	

3-17 Reference 3 Source		
Option:	Function:	
		Select the reference input to be used for the 3rd reference signal. <i>Parameter 3-15 Reference 1 Source, parameter 3-16 Reference 2 Source, and parameter 3-17 Reference 3 Source</i> define up to 3 different reference signals. The sum of these reference signals defines the actual reference.
[0]	No function	
[1]	Analog Input 53	
[2]	Analog Input 54	
[7]	Pulse input 29	
[11] *	Local bus reference	

4.4.3 3-4* Ramp 1

Configure the ramp time parameters, for each of the 2 ramps (parameter group 3-4* *Ramp 1* and parameter group 3-5* *Ramp 2*). The ramp time is preset to the minimum value of 10 ms for all power sizes.

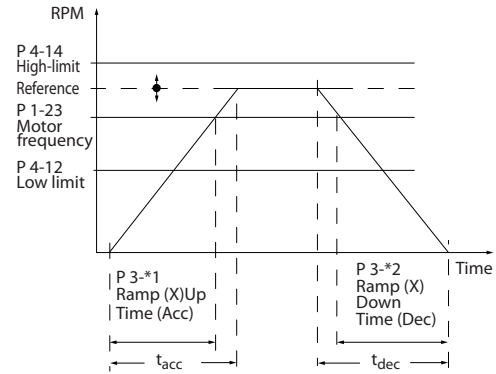

13088801.10

Illustration 4.8 Ramps

3-41 Ramp 1 Ramp Up Time		
Range:	Function:	
Size related*	[0.05 - 3600 s]	Enter acceleration time from 0 Hz to <i>parameter 1-23 Motor Frequency</i> if asynchronous motor is selected. Enter acceleration time from 0 RPM, to <i>parameter 1-25 Motor Nominal Speed</i> if PM motor is selected. Select a ramp-up time such that the output current does not exceed the current limit in <i>parameter 4-18 Current Limit</i> during ramping. See ramp-down time in <i>parameter 3-42 Ramp 1 Ramp Down Time</i> .

3-42 Ramp 1 Ramp Down Time		
Range:	Function:	
Size related*	[0.05 - 3600 s]	If asynchronous motor is selected, enter deceleration time from <i>parameter 1-23 Motor Frequency</i> to 0 Hz. If PM motor is selected, enter deceleration time from <i>parameter 1-25 Motor Nominal Speed</i> to 0 RPM. Select a ramp-down time to avoid tripping on overvoltage in the DC-link.

4.4.4 3-5* Ramp 2

This parameter group configures ramp 2 parameters.

3-51 Ramp 2 Ramp Up Time		
Range:		Function:
Size related*	[0.05 - 3600 s]	If asynchronous motor is selected, enter acceleration time from 0 Hz to <i>parameter 1-23 Motor Frequency</i> . If PM motor is selected, enter acceleration time from 0 RPM to <i>parameter 1-25 Motor Nominal Speed</i> . Select a ramp-up time such that the output current does not exceed the current limit in <i>parameter 4-18 Current Limit</i> during ramping up.

3-52 Ramp 2 Ramp Down Time		
Range:		Function:
Size related*	[0.05 - 3600 s]	Enter deceleration time from <i>parameter 1-25 Motor Nominal Speed</i> to 0 RPM. Select a ramp-down time such that the output current does not exceed the current limit in <i>parameter 4-18 Current Limit</i> during ramping down.

4.4.5 3-8* Other Ramps

3-80 Jog Ramp Time		
Range:		Function:
Size related*	[0.05 - 3600 s]	Enter the jog ramp time, which is the acceleration/deceleration time between 0 Hz to <i>parameter 1-23 Motor Frequency</i> . Ensure that the resulting output current required for the given jog ramp time does not exceed the current limit in <i>parameter 4-18 Current Limit</i> . The jog ramp time starts after activation of a jog signal via the control panel, a selected digital input, or the serial communication port.

3-81 Quick Stop Ramp Time		
Range:		Function:
Size related*	[0.05 - 3600 s]	Enter the quick stop ramp time from the <i>parameter 1-23 Motor Frequency</i> to 0 Hz. During ramping, no overvoltage may occur in the inverter, nor may the generated current exceed the limit in <i>parameter 4-18 Current Limit</i> . Quick stop is activated with a signal on a selected digital input or via the serial communication port.

3-85 Check Valve Ramp Time		
Range:		Function:
0 s*	[0 - 60 s]	To protect ball check valves in a stop situation, the check valve ramp can be utilized as a speed down ramp rate. Set the ramp rate from <i>parameter 4-11 Motor Speed Low Limit [RPM]</i> or <i>parameter 4-12 Motor Speed Low Limit [Hz]</i> to check valve ramp end speed, set in <i>parameter 3-86 Check Valve Ramp End Speed [RPM]</i> or <i>parameter 3-87 Check Valve Ramp End Speed [HZ]</i> . When <i>parameter 3-85 Check Valve Ramp Time</i> is different from 0 s, the check valve ramp time is effectuated and is used to ramp down the speed from motor speed low limit to the check valve end speed in <i>parameter 3-86 Check Valve Ramp End Speed [RPM]</i> or <i>parameter 3-87 Check Valve Ramp End Speed [HZ]</i> . See <i>Illustration 4.9</i> .

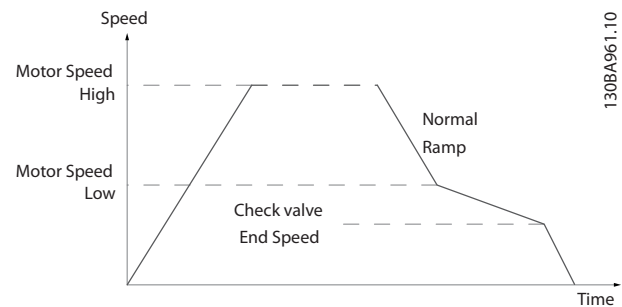

Illustration 4.9 Check Valve Ramp

3-87 Check Valve Ramp End Speed [HZ]		
Range:		Function:
Size related*	[0 - 400 Hz]	Set the speed in [Hz] below motor speed low limit where the check valve ramp is no longer active. See <i>Illustration 4.9</i> .

4.5 Main Menu - Limits/Warnings - Group 4

4.5.1 4-1* Motor Limits

Define current and speed limits for the motor, and the reaction of the frequency converter when the limits are exceeded.

4-10 Motor Speed Direction		
Option:	Function:	
[0]	Clockwise	<p>NOTICE</p> <p>The setting in <i>parameter 4-10 Motor Speed Direction</i> has impact on <i>parameter 1-73 Flying Start</i>.</p> <p>Only operation in clockwise direction is allowed.</p>
[2] *	Both directions	Operation in both clockwise and counter-clockwise directions are allowed.

4-12 Motor Speed Low Limit [Hz]		
Range:	Function:	
0 Hz*	[0 - 400.0 Hz]	Enter the minimum limit for motor speed. The motor speed low limit can be set to correspond to the minimum output frequency of the motor shaft. The speed low limit must not exceed the setting in <i>parameter 4-14 Motor Speed High Limit [Hz]</i> .

4-14 Motor Speed High Limit [Hz]		
Range:	Function:	
Size related*	[0.1 - 400.0 Hz]	Enter the maximum limit for motor speed. It can be set to match the recommended maximum motor speed. The motor speed high limit must exceed the value in <i>parameter 4-12 Motor Speed Low Limit [Hz]</i> .
		Motor speed high limit cannot be set higher than <i>parameter 4-19 Max Output Frequency</i> .

4-18 Current Limit		
Range:	Function:	
Size related*	[0 - 300 %]	Enter the current limit for motor and generator operation (in % of rated motor current). If the value is higher than maximum rated output from frequency converter, current is still limited to the maximum output current of the frequency converter. If a setting in <i>parameter 1-00 Configuration Mode</i> to <i>parameter 1-25 Motor Nominal Speed</i> is changed, <i>parameter 4-18 Current Limit</i> is not automatically reset to the default setting.

4-19 Max Output Frequency		
Range:	Function:	
Size related*	[0 - 400 Hz]	Enter the maximum output frequency, which defines the absolute limit on the frequency converter output frequency for improved safety in applications where unintended overspeeding must be avoided. This absolute limit applies to all configurations and is independent of the setting in <i>parameter 1-00 Configuration Mode</i> .

4

4.5.2 4-4* Adjustable Warnings 2

4-40 Warning Freq. Low		
Range:	Function:	
Size related*	[0 - 400 Hz]	Use this parameter to set a lower limit for the frequency range. When the motor speed drops below this limit, the display reads <i>SPEED LOW</i> . Warning bit 10 is set in <i>parameter 16-94 Ext. Status Word</i> . The output relay or the digital output can be configured to indicate this warning. The LCP warning indicator light is not turned on when this parameter set limit is reached.

4-41 Warning Freq. High		
Range:	Function:	
Size related*	[0 - 400 Hz]	Use this parameter to set a higher limit for the frequency range. When the motor speed exceeds this limit, the display reads <i>SPEED HIGH</i> . Warning bit 9 is set in <i>parameter 16-94 Ext. Status Word</i> . The output relay or the digital output can be configured to indicate this warning. The LCP warning indicator light is not turned on when this parameter set limit is reached.

4.5.3 4-5* Adj. Warnings

Define adjustable warning limits for current. Warnings are shown on the display, programmed output, or fieldbus.

4-50 Warning Current Low		
Range:	Function:	
0 A*	[0 - 194.0 A]	Enter the I_{LOW} value. When the motor current drops below this limit, a bit in the status word is set. This value can also be programmed to produce a signal on the digital output or the relay output.

4-51 Warning Current High		
Range:		Function:
Size related*	[0.0 - 194.0 A]	Enter the I _{HIGH} value. When the motor current exceeds this limit, a bit in the status word is set. This value can also be programmed to produce a signal on the digital output or the relay output.

4-54 Warning Reference Low		
Range:		Function:
-4999*	[-4999 - 4999]	Enter the lower reference limit. When the actual reference drops below this limit, the display reads <i>Ref_{LOW}</i> . The signal outputs can be programmed to produce a status signal on terminal 27 or 29 and on relay output 01 or 02.

4-55 Warning Reference High		
Range:		Function:
4999*	[-4999 - 4999]	Use this parameter to set a higher limit for the reference range. When the actual reference exceeds this limit, the display reads <i>Reference High</i> . Warning bit 19 is set in <i>parameter 16-94 Ext. Status Word</i> . The output relay or the digital output can be configured to indicate this warning. The LCP warning indicator light is not turned on when this parameter set limit is reached.

4-56 Warning Feedback Low		
Range:		Function:
-4999 ProcessCtrlUnit*	[-4999 - 4999 ProcessCtrlUnit]	Use this parameter to set a lower limit for the feedback range. When the feedback drops below this limit, the display reads <i>Feedback Low</i> . Warning bit 6 is set in <i>parameter 16-94 Ext. Status Word</i> . The output relay or digital output can be configured to indicate this warning. The LCP warning indicator light does not light up when this parameter set limit is reached.

4-57 Warning Feedback High		
Range:		Function:
4999 ProcessCtrlUnit*	[-4999 - 4999 ProcessCtrlUnit]	Use this parameter to set a higher limit for the feedback range. When the feedback exceeds this limit, the display reads <i>Feedback High</i> . Warning bit 5

4-57 Warning Feedback High		
Range:		Function:
		is set in <i>parameter 16-94 Ext. Status Word</i> . The output relay or digital output can be configured to indicate this warning. The LCP warning indicator light does not light up when this parameter set limit is reached.

4-58 Missing Motor Phase Function		
Option:		Function:
[0]	Off	No alarm is shown if a missing motor phase occurs.
[1] *	On	An alarm is shown if a missing motor phase occurs.

4.5.4 4-6* Speed Bypass

Define the speed bypass areas for the ramps. 3 frequency ranges can be avoided.

4-61 Bypass Speed From [Hz]		
Range:		Function:
0 Hz*	[0 - 500 Hz]	Some systems call for avoiding certain output speeds due to resonance problems in the system. Enter the lower limits of the speeds to be avoided.

4-63 Bypass Speed To [Hz]		
Range:		Function:
0 Hz*	[0 - 500 Hz]	Some systems call for avoiding certain output speeds due to resonance problems in the system. Enter the upper limits of the speeds to be avoided.

4.5.5 Semi-Automatic Bypass Speed Set-up

Use the semi-automatic bypass speed set-up to facilitate the programming of the frequencies to be skipped due to resonances in the system.

Procedure:

1. Stop the motor.

NOTICE

Adjust the ramp times in *parameter 3-41 Ramp 1 Ramp Up Time* and *parameter 3-42 Ramp 1 Ramp Down Time*.

2. Select [1] Enabled in *parameter 4-64 Semi-Auto Bypass Set-up*.
3. Press [Hand On] to start the search for frequency bands causing resonances. The motor ramps up according to the ramp set.

NOTICE

Terminal 27 digital input parameter 5-12 Terminal 27 Digital Input has [2] Coast inverse as default setting. If there is no 24 V to terminal 27, [Hand On] does not start the motor. If so, connect terminal 12 to terminal 27.

4. When sweeping through a resonance band, press [OK] on the LCP when leaving the band. The actual frequency is stored as the first element in *parameter 4-63 Bypass Speed To [Hz]* (array). Repeat this procedure for each resonance band identified at the ramp-up (maximum of 3 can be adjusted).
5. When maximum speed has been reached, the motor automatically begins to ramp down. Repeat this procedure when speed is leaving the resonance bands during the deceleration. The actual frequencies registered when pressing [OK] are stored in *parameter 4-61 Bypass Speed From [Hz]*.
6. When the motor has ramped down to stop, press [OK]. The *parameter 4-64 Semi-Auto Bypass Set-up* automatically resets to *off*. The frequency converter stays in hand on mode until [Off] or [Auto On] is pressed.

If the frequencies for a certain resonance band are not registered in the right order (frequency values stored in *parameter 4-63 Bypass Speed To [Hz]* are \geq the values in *parameter 4-61 Bypass Speed From [Hz]*), or if they do not have the same numbers of registrations for the *parameter 4-61 Bypass Speed From [Hz]* and *parameter 4-63 Bypass Speed To [Hz]*, all registrations are canceled and the following message is shown: *Collected speed areas overlapping or not determined. Press [Cancel] to abort.*

4-64 Semi-Auto Bypass Set-up	
Option:	Function:
[0] * Off	
[1]	Enable If this option is selected, speed ranges are automatically swept to identify bands of resonances.

4.6 Main Menu - Digital In/Out - Group 5

4.6.1 5-0* Digital I/O Mode

Parameters for configuring the input and output using NPN and PNP.

NOTICE

These parameters cannot be adjusted while the motor runs.

5-00 Digital Input Mode		
Option:	Function:	
		Set NPN or PNP mode for digital inputs 18, 19, and 27. Digital input mode.
[0] *	PNP	Action on positive directional pulses (0). PNP systems are pulled down to ground (GND).
[1]	NPN	Action on negative directional pulses (1). NPN systems are pulled up to +24 V, internally in the frequency converter.

5-01 Terminal 27 Mode		
Option:	Function:	
		NOTICE This parameter cannot be adjusted while the motor runs.
[0] *	Input	Defines terminal 27 as a digital input.
[1]	Output	Defines terminal 27 as a digital output.

5-02 Terminal 29 Mode		
Option:	Function:	
		NOTICE This parameter cannot be adjusted while the motor runs.
[0] *	Input	Defines terminal 29 as a digital input.
[1]	Output	Defines terminal 29 as a digital output.

4.6.2 5-1* Digital Inputs

Parameters for configuring the input functions for the input terminals.

The digital inputs are used for selecting various functions in the frequency converter. All digital inputs can be set to the following functions:

Digital input function	Description
[0] No operation	No reaction to signals transmitted to the terminal.
[1] Reset	Resets the frequency converter after a trip/alarm. Trip lock alarms can be reset.
[2] Coast inverse	Leaves the motor in free mode. Logic 0⇒coast stop.
[3] Coast and reset inverse	Reset and coast stop inverted input (NC). Leaves the motor in free mode and resets the frequency converter. Logic 0⇒coast stop and reset.
[4] Quick stop inverse	Inverted input (NC). Generates a stop in accordance with the quick-stop ramp time set in <i>parameter 3-81 Quick Stop Ramp Time</i> . After ramping down, the shaft is in free mode.
[5] DC brake inverse	Inverted input for DC braking (NC). Stops the motor by energizing it with DC current for a certain time period, see <i>parameter 2-01 DC Brake Current</i> . The function is only active when the value in <i>parameter 2-02 DC Braking Time</i> is different from 0. This selection is not possible when <i>parameter 1-10 Motor Construction</i> is set to [1] <i>PM non-salient SPM</i> .
[6] Stop inverse	The stop inverse function generates the stop function when the selected terminal goes from logical level 1 to 0 (not latched). Stop is performed according to selected ramp time.
[7] External Interlock	Same function as coast stop, inverse, but external interlock generates the alarm message <i>external fault</i> on the display when the terminal programmed for coast inverse is logic 0. If programmed for external interlock, the alarm message is also active via digital outputs and relay outputs. If the cause for the external interlock is removed, the alarm can be reset using a digital input, fieldbus, or the [Reset] key.
[8] Start	Select start for a start/stop command. Logic 1=start, logic 0=stop. (Default digital input 18).
[9] Latched start	If a pulse is applied for a minimum of 2 ms, the motor starts. The motor stops when stop inverse is activated.
[10] Reversing	Change direction of motor shaft rotation. The reversing signal only changes the direction of rotation, it does not activate the start function. Select [2] <i>Both directions</i> in <i>parameter 4-10 Motor Speed Direction</i> . 0=normal, 1=reversing.

Digital input function	Description
[11] Start reversing	Use for start/stop and for reversing at the same time. Signals on [8] start are not allowed at the same time. 0=stop, 1=start reversing.
[14] Jog	Used for activating jog speed. See <i>parameter 3-11 Jog Speed [Hz]</i> . (Default digital input 29).
[16] Preset ref bit 0	Enables a selection of 1 of the 8 preset references according to <i>Table 4.5</i> .
[17] Preset ref bit 1	Enables a selection of 1 of the 8 preset references according to <i>Table 4.5</i> .
[18] Preset ref bit 2	Enables a selection of 1 of the 8 preset references according to <i>Table 4.5</i> .
[19] Freeze reference	Freeze actual reference. The frozen reference is now the point of enable/condition for speed up and speed down to be used. If speed up/speed down is used, a speed change always follows ramp 2 (<i>parameter 3-51 Ramp 2 Ramp Up Time</i> and <i>parameter 3-52 Ramp 2 Ramp Down Time</i>) in the range <i>parameter 3-02 Minimum Reference - parameter 3-03 Maximum Reference</i> .
[20] Freeze output	Freezes actual reference. The frozen reference is now the point of enable/condition for speed up and speed down to be used. If speed up/speed down is used, the speed change always follows ramp 2.
[21] Speed up	For digital control of the up/down speed (motor potentiometer). Activate this function by selecting either freeze reference or freeze output. When speed up is activated for less than 400 ms, the resulting reference is increased by 0.1%. If speed up is activated for more than 400 ms, the resulting reference ramps according to ramp 1 in <i>parameter 3-41 Ramp 1 Ramp Up Time</i> .
[22] Speed down	Same as [21] <i>Speed up</i> , but reference decreases.
[23] Set-up select bit 0	Selects 1 of the 2 set-ups. Set <i>parameter 0-10 Active Set-up</i> to multi set-up.
[32] Pulse Input	Select pulse input when using a pulse sequence as either reference or feedback. Scaling is done in parameter group 5-5* <i>Pulse Input</i> . Available only for terminal 29.
[34] Ramp bit 0	Select which ramp to use. Logic 0 selects ramp 1, while logic 1 selects ramp 2.
[37] Fire mode	A signal applied puts the frequency converter into fire mode and disregards all other commands. See 24-0* <i>Fire Mode</i> .

Digital input function	Description
[52] Run permissive	The input terminal, for which the run permissive is programmed, must be logic 1 before a start command can be accepted. Run permissive has a logic AND function related to the terminal, which is programmed for [8] Start, [14] Jog, or [20] Freeze Output. To start running the motor, both conditions must be fulfilled. If run permissive is programmed on multiple terminals, run permissive only has to be logic 1 on 1 of the terminals for the function to be carried out. Run permissive does not affect the digital output signal for run request ([8] Start, [14] Jog, or [20] Freeze Output) programmed in parameter group 5-3* <i>Digital Outputs</i> , or parameter group 5-4* <i>Relays</i> . NOTICE If no run permissive signal is applied but either run, jog, or freeze commands is activated, the status line in the display shows either Run Requested, Jog Requested, or Freeze Requested.
[53] Hand Start	A signal applied puts the frequency converter into hand on mode as if [Hand On] is pressed and a normal stop command is overridden. If the signal is disconnected, the motor stops. To make any other start commands valid, assign another digital input to Auto Start and apply a signal. The [Hand On] and [Auto On] keys have no impact. The [Off] key overrides Hand Start and Auto Start. Press either [Hand On] or [Auto On] to reactivate Hand Start and Auto Start. If there is no signal on Hand Start or Auto Start, the motor stops regardless of any normal start command applied. If a signal is applied to both Hand Start and Auto Start, the function is Auto Start.
[54] Auto start	A signal applied puts the frequency converter into Auto mode as if [Auto On] is pressed. See also [53] Hand Start.
[60] Counter A (up)	Input for increment counting in the SLC counter.
[61] Counter A (down)	Input for decrement counting in the SLC counter.
[62] Reset Counter A	Input for reset of counter A.
[63] Counter B (up)	Input for increment counting in the SLC counter.

Digital input function	Description
[64] Counter B (down)	Input for decrement counting in the SLC counter.
[65] Reset Counter B	Input for reset of counter B

Table 4.4 Digital Input Functions

Selected preset reference:	Preset reference bit 2	Preset reference bit 1	Preset reference bit 0
Preset reference 0	0	0	0
Preset reference 1	0	0	1
Preset reference 2	0	1	0
Preset reference 3	0	1	1
Preset reference 4	1	0	0
Preset reference 5	1	0	1
Preset reference 6	1	1	0
Preset reference 7	1	1	1

Table 4.5 Selected Preset Reference

5-10 Terminal 18 Digital Input		
Parameter for configuring the input function on input terminal 18. Refer to Table 4.4 for setting options.		
Option:	Function:	
[0]	No operation	
[1]	Reset	
[2]	Coast inverse	
[3]	Coast and reset inverse	
[4]	Quick stop inverse	
[5]	DC-brake inverse	
[6]	Stop inverse	
[7]	External Interlock	
[8] *	Start	
[9]	Latched start	
[10]	Reversing	
[11]	Start reversing	
[14]	Jog	
[16]	Preset ref bit 0	
[17]	Preset ref bit 1	
[18]	Preset ref bit 2	
[19]	Freeze reference	
[20]	Freeze output	
[21]	Speed up	
[22]	Speed down	

5-10 Terminal 18 Digital Input		
Parameter for configuring the input function on input terminal 18. Refer to Table 4.4 for setting options.		
Option:	Function:	
[23]	Set-up select bit 0	
[34]	Ramp bit 0	
[37]	Fire Mode	
[52]	Run permissive	
[53]	Hand start	
[54]	Auto start	
[60]	Counter A (up)	
[61]	Counter A (down)	
[62]	Reset Counter A	
[63]	Counter B (up)	
[64]	Counter B (down)	
[65]	Reset Counter B	
[101]	Sleep	

5-11 Terminal 19 Digital Input		
Parameter for configuring the input function on input terminal 19.		
Option:	Function:	
[0] *	No operation	
[1]	Reset	
[2]	Coast inverse	
[3]	Coast and reset inverse	
[4]	Quick stop inverse	
[5]	DC-brake inverse	
[6]	Stop inverse	
[7]	External Interlock	
[8]	Start	
[9]	Latched start	
[10]	Reversing	
[11]	Start reversing	
[14]	Jog	
[16]	Preset ref bit 0	
[17]	Preset ref bit 1	
[18]	Preset ref bit 2	
[19]	Freeze reference	
[20]	Freeze output	
[21]	Speed up	
[22]	Speed down	
[23]	Set-up select bit 0	
[34]	Ramp bit 0	
[37]	Fire Mode	
[52]	Run permissive	
[53]	Hand start	
[54]	Auto start	
[60]	Counter A (up)	
[61]	Counter A (down)	
[62]	Reset Counter A	
[63]	Counter B (up)	
[64]	Counter B (down)	
[65]	Reset Counter B	

5-11 Terminal 19 Digital Input		
Parameter for configuring the input function on input terminal 19.		
Option:	Function:	
[101]	Sleep	

5-12 Terminal 27 Digital Input		
Parameter for configuring the input function on input terminal 27. When <i>parameter 0-03 Regional Settings</i> is set to [0] <i>International</i> , the default value is [2] <i>Coast inverse</i> . When <i>parameter 0-03 Regional Settings</i> is set to [1] <i>North America</i> , the default value is [7] <i>External Interlock</i> .		
Option:	Function:	
[0]	No operation	
[1]	Reset	
[2]	Coast inverse	
[3]	Coast and reset inverse	
[4]	Quick stop inverse	
[5]	DC-brake inverse	
[6]	Stop inverse	
[7]	External Interlock	
[8]	Start	
[9]	Latched start	
[10]	Reversing	
[11]	Start reversing	
[14]	Jog	
[16]	Preset ref bit 0	
[17]	Preset ref bit 1	
[18]	Preset ref bit 2	
[19]	Freeze reference	
[20]	Freeze output	
[21]	Speed up	
[22]	Speed down	
[23]	Set-up select bit 0	
[34]	Ramp bit 0	
[37]	Fire Mode	
[52]	Run permissive	
[53]	Hand start	
[54]	Auto start	
[60]	Counter A (up)	
[61]	Counter A (down)	
[62]	Reset Counter A	
[63]	Counter B (up)	
[64]	Counter B (down)	
[65]	Reset Counter B	
[101]	Sleep	

5-13 Terminal 29 Digital Input		
Parameter for configuring the input function on input terminal 29.		
Option:	Function:	
[0]	No operation	
[1]	Reset	
[2]	Coast inverse	
[3]	Coast and reset inverse	

5-13 Terminal 29 Digital Input		
Parameter for configuring the input function on input terminal 29.		
Option:	Function:	
[4]	Quick stop inverse	
[5]	DC-brake inverse	
[6]	Stop inverse	
[7]	External Interlock	
[8]	Start	
[9]	Latched start	
[10]	Reversing	
[11]	Start reversing	
[14] *	Jog	
[16]	Preset ref bit 0	
[17]	Preset ref bit 1	
[18]	Preset ref bit 2	
[19]	Freeze reference	
[20]	Freeze output	
[21]	Speed up	
[22]	Speed down	
[23]	Set-up select bit 0	
[32]	Pulse input	
[34]	Ramp bit 0	
[37]	Fire Mode	
[52]	Run permissive	
[53]	Hand start	
[54]	Auto start	
[60]	Counter A (up)	
[61]	Counter A (down)	
[62]	Reset Counter A	
[63]	Counter B (up)	
[64]	Counter B (down)	
[65]	Reset Counter B	
[101]	Sleep	

4.6.3 5-3* Digital Outputs

Parameters for configuring the output functions for the output terminals.

5-30 Terminal 27 Digital Output		
This parameter has the options described in <i>chapter 4.6.3 5-3* Digital Outputs</i> .		
Option:	Function:	
[0] *	No operation	

5-31 Terminal 29 Digital Output		
This parameter has the options described in <i>chapter 4.6.3 5-3* Digital Outputs</i> .		
Option:	Function:	
[0] *	No operation	

5-34 On Delay, Digital Output		
Range:	Function:	
0.01 s* [0 - 600 s]	Enter the delay time before the digital output is switched on. The digital output (terminal 42/45) condition must not be interrupted during the delay time.	

5-35 Off Delay, Digital Output		
Range:	Function:	
0.01 s* [0 - 600 s]	Enter the delay time before the digital output is switched off. The digital output (terminal 42/45) condition must not be interrupted during the delay time.	

4.6.4 5-4* Relays

Parameters for configuring the timing and the output functions for the relays.

5-40 Function Relay		
Array (Relay 1 [0], Relay 2 [1])		
Select options to define the function of the relays. The selection of each mechanical relay is realized in an array parameter.		
Default values for <i>parameter 5-40 Function Relay</i> : When <i>parameter 0-03 Regional Settings</i> is set to [0] <i>International</i> , the default value of Relay1 is Alarm, and default value of Relay2 is Drive Running. When <i>parameter 0-03 Regional Settings</i> is set to [1] <i>North America</i> , the default value of Relay1 is No Alarm, and default value of Relay2 is Drive Running.		
Option:	Function:	
[0]	No operation	Default for both relays.
[1]	Control Ready	The control board receives supply voltage.
[2]	Drive ready	The frequency converter is ready for operation and applies supply signal on control board.
[3]	Drive ready/ remote control	The frequency converter is ready for operation in Auto On mode.
[4]	Standby / no warning	The frequency converter is ready for operation. No start or stop command is given. No warnings are present.
[5]	Drive running	The motor runs.
[6]	Running / no warning	The motor runs, and no warnings are present.
[7]	Run in range/no warning	The motor runs within programmed current ranges, see <i>parameter 4-50 Warning Current Low</i> and <i>parameter 4-51 Warning Current High</i> . No warnings are present.
[8]	Run on ref/no warning	The motor runs at reference speed and with no warnings.

5-40 Function Relay		
Array (Relay 1 [0], Relay 2 [1])		
Select options to define the function of the relays. The selection of each mechanical relay is realized in an array parameter.		
Default values for <i>parameter 5-40 Function Relay</i> : When <i>parameter 0-03 Regional Settings</i> is set to [0] <i>International</i> , the default value of Relay1 is Alarm, and default value of Relay2 is Drive Running. When <i>parameter 0-03 Regional Settings</i> is set to [1] <i>North America</i> , the default value of Relay1 is No Alarm, and default value of Relay2 is Drive Running.		
Option:	Function:	
[9]	Alarm	An alarm activates output.
[10]	Alarm or warning	An alarm or warning activates output.
[12]	Out of current range	The motor current is outside the range set in <i>parameter 4-50 Warning Current Low</i> and <i>parameter 4-51 Warning Current High</i> .
[13]	Below current, low	The motor current is lower than set in <i>parameter 4-50 Warning Current Low</i> .
[14]	Above current, high	The motor current is higher than set in <i>parameter 4-51 Warning Current High</i> .
[16]	Below speed, low	
[17]	Above speed, high	
[19]	Below feedback, low	
[20]	Above feedback, high	
[21]	Thermal warning	The thermal warning turns on when the temperature exceeds the limit in motor, frequency converter, or thermistor.
[22]	Ready, no thermal warning	The frequency converter is ready for operation and no overtemperature warning is present.
[23]	Remote, ready, no thermal warning	The frequency converter is ready for operation in Auto mode, and no overtemperature warning is present.
[24]	Ready, Voltage OK	The frequency converter is ready for operation, and mains voltage is within specified voltage range.
[25]	Reverse	The motor runs/is ready to run clockwise when logic = 0 and counterclockwise when logic = 1. Output changes when reversing signal is applied.
[26]	Bus OK	Active communication (no timeout) via serial communication port.
[32]	Mech brake ctrl	
[35]	External Interlock	See digital input.

5-40 Function Relay		
Array (Relay 1 [0], Relay 2 [1])		
Select options to define the function of the relays.		
The selection of each mechanical relay is realized in an array parameter.		
Default values for <i>parameter 5-40 Function Relay</i> :		
When <i>parameter 0-03 Regional Settings</i> is set to [0] <i>International</i> , the default value of Relay1 is Alarm, and default value of Relay2 is Drive Running.		
When <i>parameter 0-03 Regional Settings</i> is set to [1] <i>North America</i> , the default value of Relay1 is No Alarm, and default value of Relay2 is Drive Running.		
Option:	Function:	
[36]	Control word bit 11	Bit 11 in control word controls relay.
[37]	Control word bit 12	Bit 12 in control word controls relay.
[41]	Below reference, low	
[42]	Above ref, high	
[45]	Bus Control	
[60]	Comparator 0	See parameter group 13-1* <i>Comparators</i> . If comparator 0 is evaluated as TRUE, the output goes high. Otherwise, it is low.
[61]	Comparator 1	See parameter group 13-1* <i>Comparators</i> . If comparator 1 is evaluated as TRUE, the output goes high. Otherwise, it is low.
[62]	Comparator 2	See parameter group 13-1* <i>Comparators</i> . If comparator 2 is evaluated as TRUE, the output goes high. Otherwise, it is low.
[63]	Comparator 3	See parameter group 13-1* <i>Comparators</i> . If comparator 3 is evaluated as TRUE, the output goes high. Otherwise, it is low.
[64]	Comparator 4	See parameter group 13-1* <i>Comparators</i> . If comparator 4 is evaluated as TRUE, the output goes high. Otherwise, it is low.
[65]	Comparator 5	See parameter group 13-1* <i>Comparators</i> . If comparator 5 is evaluated as TRUE, the output goes high. Otherwise, it is low.
[70]	Logic rule 0	See parameter group 13-4* <i>Logic Rules</i> . If logic rule 0 is evaluated as TRUE, the output goes high. Otherwise, it is low.
[71]	Logic rule 1	See parameter group 13-4* <i>Logic Rules</i> . If logic rule 1 is evaluated as TRUE, the output goes high. Otherwise, it is low.
[72]	Logic rule 2	See parameter group 13-4* <i>Logic Rules</i> . If logic rule 2 is evaluated as TRUE, the output goes high. Otherwise, it is low.
[73]	Logic rule 3	See parameter group 13-4* <i>Logic Rules</i> . If logic rule 3 is evaluated as TRUE, the output goes high. Otherwise, it is low.

5-40 Function Relay		
Array (Relay 1 [0], Relay 2 [1])		
Select options to define the function of the relays.		
The selection of each mechanical relay is realized in an array parameter.		
Default values for <i>parameter 5-40 Function Relay</i> :		
When <i>parameter 0-03 Regional Settings</i> is set to [0] <i>International</i> , the default value of Relay1 is Alarm, and default value of Relay2 is Drive Running.		
When <i>parameter 0-03 Regional Settings</i> is set to [1] <i>North America</i> , the default value of Relay1 is No Alarm, and default value of Relay2 is Drive Running.		
Option:	Function:	
[74]	Logic rule 4	See parameter group 13-4* <i>Logic Rules</i> . If logic rule 4 is evaluated as TRUE, the output goes high. Otherwise, it is low.
[75]	Logic rule 5	See parameter group 13-4* <i>Logic Rules</i> . If logic rule 5 is evaluated as TRUE, the output goes high. Otherwise, it is low.
[80]	SL digital output A	See <i>parameter 13-52 SL Controller Action</i> . The input goes high whenever the smart logic action [38] <i>Set dig. out. A high</i> is executed. The input goes low whenever the smart logic [32] <i>Action Set dig. out. A low</i> is executed.
[81]	SL digital output B	See <i>parameter 13-52 SL Controller Action</i> . The input goes high whenever the smart logic action [39] <i>Set dig. out. B high</i> is executed. The input goes low whenever the smart logic [33] <i>Action Set dig. out. B low</i> is executed.
[82]	SL digital output C	See <i>parameter 13-52 SL Controller Action</i> . The input goes high whenever the smart logic action [40] <i>Set dig. out. C high</i> is executed. The input goes low whenever the smart logic [34] <i>Action Set dig. out. C low</i> is executed.
[83]	SL digital output D	See <i>parameter 13-52 SL Controller Action</i> . The input goes high whenever the smart logic [41] <i>Action Set dig. out. D high</i> is executed. The input goes low whenever the smart logic [35] <i>Action Set dig. out. D low</i> is executed.
[160]	No alarm	The output is high when no alarm is present.
[161]	Running reverse	The output is high when the frequency converter runs counterclockwise (the logical product of the status bits running AND reverse).
[165]	Local ref. active	The output is high when <i>parameter 3-13 Reference Site</i> = [2] <i>Local</i> or when <i>parameter 3-13 Reference Site</i> =

5-40 Function Relay		
Array (Relay 1 [0], Relay 2 [1])		
Select options to define the function of the relays.		
The selection of each mechanical relay is realized in an array parameter.		
Default values for <i>parameter 5-40 Function Relay</i> :		
When <i>parameter 0-03 Regional Settings</i> is set to [0] <i>International</i> , the default value of Relay1 is Alarm, and default value of Relay2 is Drive Running.		
When <i>parameter 0-03 Regional Settings</i> is set to [1] <i>North America</i> , the default value of Relay1 is No Alarm, and default value of Relay2 is Drive Running.		
Option:	Function:	
	[0] <i>Linked to hand auto</i> at the same time as the LCP is in [Hand on] mode.	
[166] Remote ref. active	The output is high when <i>parameter 3-13 Reference Site [1]</i> or <i>Linked to hand/auto [0]</i> while the LCP is in [Auto on] mode.	
[167] Start command activ	The output is high when there is an active start command (that is via digital input bus connection or [Hand on] or [Auto on]), and no stop command is active.	
[168] Drive in hand mode	The output is high when the frequency converter is in hand on mode (as indicated by the LED light above [Hand on]).	
[169] Drive in auto mode	The output is high when the frequency converter is in auto on mode (as indicated by the LED light above [Auto on]).	
[191] Dry Pump		
[192] End Of Curve		
[193] Sleep Mode	The frequency converter/system is in sleep mode. See parameter group 22-4* - <i>Sleep Mode</i> .	
[194] Broken Belt Function	A broken-belt condition is detected. Enable this function in <i>parameter 22-60 Broken Belt Function</i> .	
[196] Fire Mode	The frequency converter is operating in fire mode. See parameter group 24-0* <i>Fire mode</i> .	
[198] Drive Bypass	To be used as signal for activating an external electromechanical bypass, switching the motor direct on line. See 24-1* <i>Drive Bypass</i> .	
[235] Check Valve Ramping		

5-41 On Delay, Relay		
Array [9] (Relay 1 [0], Relay 2 [1], Relay 3 [2], Relay 4 [3], Relay 5 [4], Relay 6 [5], Relay 7 [6], Relay 8 [7], Relay 9 [8])		
Range:	Function:	
0.01 s* s]	[0.01 - 600	Enter the delay of the relay cut-in time. The relay only cuts in if the condition in <i>parameter 5-40 Function Relay</i> is uninterrupted during the specified time. Select 1 of the available mechanical relays in an array function. See <i>parameter 5-40 Function Relay</i> .

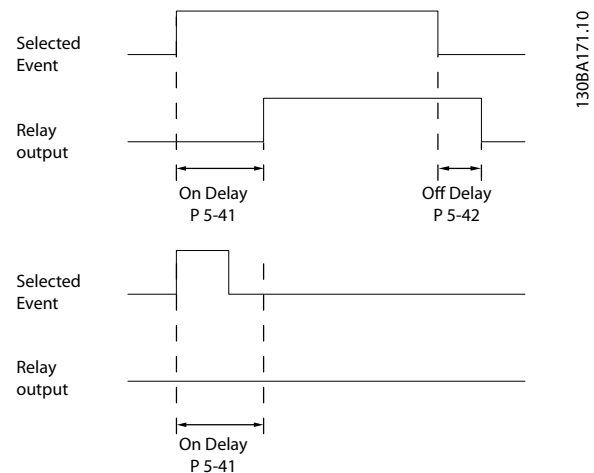

Illustration 4.10 On Delay, Relay

5-42 Off Delay, Relay		
Array[2]: Relay1[0], Relay2[1]		
Range:	Function:	
0.01 s* s]	[0.01 - 600	Enter the delay of the relay cut-out time. Select 1 of the available mechanical relays in an array function. See <i>parameter 5-40 Function Relay</i> .

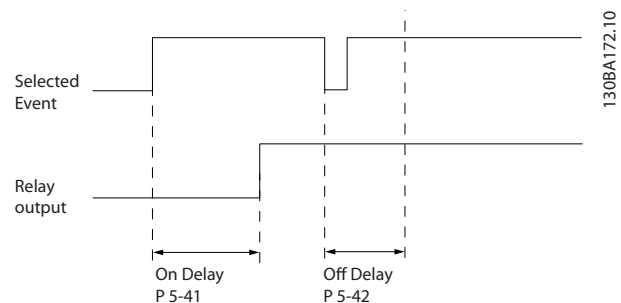

Illustration 4.11 Off Delay, Relay

If the selected event condition changes before the on- or off delay timer expires, the relay output is unaffected.

4.6.5 5-5* Pulse Input

The pulse input parameters are used to define an appropriate window for the impulse reference area by configuring the scaling and filter settings for the pulse inputs. Input terminal 29 acts as frequency reference inputs. Set terminal 29 (*parameter 5-13 Terminal 29 Digital Input* to [32] *Pulse input*).

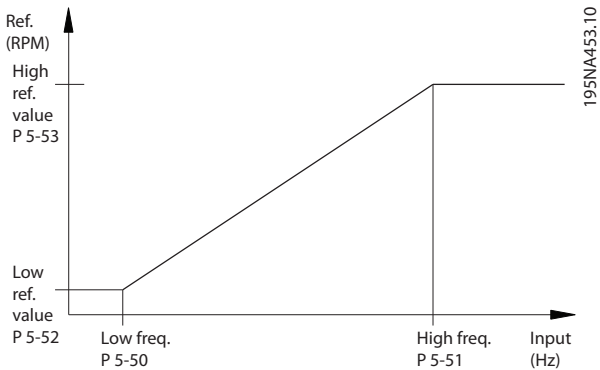

Illustration 4.12 Pulse Input

5-50 Term. 29 Low Frequency		
Range:	Function:	
20 Hz* [20 - 31999 Hz]	Enter the low frequency limit corresponding to the low motor shaft speed (that is low reference value) in <i>parameter 5-52 Term. 29 Low Ref./Feedb. Value</i> . Refer to <i>Illustration 4.12</i> .	

5-51 Term. 29 High Frequency		
Range:	Function:	
32000 Hz* [21 - 32000 Hz]	Enter the high frequency limit corresponding to the high motor shaft speed (that is high reference value) in <i>parameter 5-53 Term. 29 High Ref./Feedb. Value</i> .	

5-52 Term. 29 Low Ref./Feedb. Value		
Range:	Function:	
0* [-4999 - 4999]	Enter the low reference value limit for the motor shaft speed [RPM]. This value is also the lowest feedback value, see also <i>parameter 5-13 Terminal 29 Digital Input = [32] Pulse Input</i> .	

5-53 Term. 29 High Ref./Feedb. Value		
Range:	Function:	
Size related* [-4999 - 4999]	Enter the high reference value [RPM] for the motor shaft speed and the high feedback value, see also <i>parameter 5-13 Terminal 29 Digital Input = [32] Pulse Input</i> .	

4.6.6 5-9* Bus Controlled

This parameter group selects digital and relay outputs via a fieldbus setting.

5-90 Digital & Relay Bus Control		
Range:	Function:	
0* [0 - 0xFFFFFFFF]	This parameter holds the state of the digital outputs and relays controlled by bus. A logical 1 indicates that the output is high or active. A logical 0 indicates that the output is low or inactive.	

Bit 0-3	Reserved
Bit 4	Relay 1 output terminal
Bit 5	Relay 2 output terminal
Bit 6-23	Reserved
Bit 24	Terminal 42 digital output
Bit 25	Terminal 45 digital output
Bit 26-31	Reserved

Table 4.6 Bit Functions

4.7 Main Menu - Analog In/Out - Group 6

Parameter group for setting up the analog I/O configuration and the digital output. The frequency converter provides 2 analog inputs:

- Terminal 53.
- Terminal 54.

The analog inputs can be freely allocated to either voltage (0–10 V) or current input (0/4–20 mA)

4.7.1 6-0* Analog I/O Mode

6-00 Live Zero Timeout Time		
Range:	Function:	
10 s*	[1 - 99 s]	Enter the timeout time.

6-01 Live Zero Timeout Function		
Option:	Function:	
	Select the timeout function. The function set in <i>parameter 6-01 Live Zero Timeout Function</i> is activated, if the input signal on terminal 53 or 54 is below 50% of the value in <i>parameter 6-10 Terminal 53 Low Voltage</i> , <i>parameter 6-12 Terminal 53 Low Current</i> , <i>parameter 6-20 Terminal 54 Low Voltage</i> , or <i>parameter 6-22 Terminal 54 Low Current</i> for a time period defined in <i>parameter 6-00 Live Zero Timeout Time</i> .	
[0] *	Off	
[1]	Freeze output	
[2]	Stop	
[3]	Jogging	
[4]	Max. speed	
[5]	Stop and trip	

4.7.2 6-1* Analog Input 53

Parameters for configuring the scaling and limits for analog input 53 (terminal 53).

6-10 Terminal 53 Low Voltage		
Range:	Function:	
0.07 V*	[0 - 10 V]	Enter the voltage (V) that corresponds to <i>parameter 6-14 Terminal 53 Low Ref./Feedb. Value</i> . To activate <i>parameter 6-01 Live Zero Timeout Function</i> , set the value at >1 V.

6-11 Terminal 53 High Voltage		
Range:	Function:	
10 V*	[0 - 10 V]	Enter the voltage (V) that corresponds to the high reference value (set in <i>parameter 6-15 Terminal 53 High Ref./Feedb. Value</i>).

6-12 Terminal 53 Low Current		
Range:	Function:	
4 mA*	[0 - 20 mA]	Enter the low current value. This reference signal corresponds to the low reference/feedback value that is set in <i>parameter 6-14 Terminal 53 Low Ref./Feedb. Value</i> . To activate <i>parameter 6-01 Live Zero Timeout Function</i> , set the value to >2 mA.

6-13 Terminal 53 High Current		
Range:	Function:	
20 mA*	[0 - 20 mA]	Enter the high current value corresponding to the high reference/feedback set in <i>parameter 6-15 Terminal 53 High Ref./Feedb. Value</i> .

6-14 Terminal 53 Low Ref./Feedb. Value		
Range:	Function:	
0*	[-4999 - 4999]	Enter the reference or feedback value that corresponds to the voltage or current set in <i>parameter 6-10 Terminal 53 Low Voltage</i> to <i>parameter 6-12 Terminal 53 Low Current</i> .

6-15 Terminal 53 High Ref./Feedb. Value		
Range:	Function:	
Size related*	[-4999 - 4999]	Enter the reference or feedback value that corresponds to the voltage or current set in <i>parameter 6-11 Terminal 53 High Voltage</i> to <i>parameter 6-13 Terminal 53 High Current</i> .

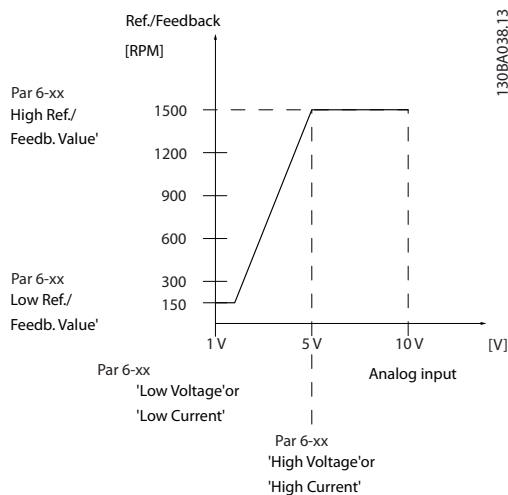

Illustration 4.13 Live Zero Timeout Function

6-16 Terminal 53 Filter Time Constant		
Range:		Function:
0.01 s* [0.01 - 10 s]		Enter the time constant. This constant is a first-order digital low-pass filter time constant for suppressing electrical noise in terminal 53. A high time constant value improves dampening, but also increases the time delay through the filter.

6-19 Terminal 53 mode		
Option:		Function:
		Select whether terminal 53 is used for current or voltage input.
[0]	Current mode	
[1] *	Voltage mode	

4.7.3 6-2* Analog Input 54

Parameters for configuring the scaling and limits for analog input 54 (terminal 54).

6-20 Terminal 54 Low Voltage		
Range:		Function:
0.07 V* [0 - 10 V]		Enter the voltage (V) that corresponds to the low reference value (set in <i>parameter 6-24 Terminal 54 Low Ref./Feedb. Value</i>). To activate <i>parameter 6-01 Live Zero Timeout Function</i> , set the value at >1 V.

6-21 Terminal 54 High Voltage		
Range:		Function:
10 V* [0 - 10 V]		Enter the voltage (V) that corresponds to the high reference value (set in <i>parameter 6-25 Terminal 54 High Ref./Feedb. Value</i>).

6-22 Terminal 54 Low Current		
Range:		Function:
4 mA* [0 - 20 mA]		Enter the low current value. This reference signal corresponds to the low reference/feedback value, set in <i>parameter 6-24 Terminal 54 Low Ref./Feedb. Value</i> . To activate the live zero timeout function in <i>parameter 6-01 Live Zero Timeout Function</i> , set the value to >2 mA.

6-23 Terminal 54 High Current		
Range:		Function:
20 mA* [0 - 20 mA]		Enter the high current value corresponding to the high reference/feedback value set in <i>parameter 6-25 Terminal 54 High Ref./Feedb. Value</i> .

6-24 Terminal 54 Low Ref./Feedb. Value		
Range:		Function:
0* [-4999 - 4999]		Enter the reference or feedback value that corresponds to the voltage or current set in <i>parameter 6-21 Terminal 54 High Voltage/parameter 6-22 Terminal 54 Low Current</i> .

6-25 Terminal 54 High Ref./Feedb. Value		
Range:		Function:
Size related* [-4999 - 4999]		Enter the reference or feedback value that corresponds to the voltage or current set in <i>parameter 6-21 Terminal 54 High Voltage/parameter 6-23 Terminal 54 High Current</i> .

6-26 Terminal 54 Filter Time Constant		
Range:		Function:
0.01 s* [0.01 - 10 s]		Enter the time constant, which is a first-order digital low-pass filter time constant for suppressing electrical noise in terminal 54. A high time constant value improves dampening, but also increases the time delay through the filter.

6-29 Terminal 54 mode		
Option:		Function:
		Select if terminal 54 is used for current input or voltage input.
[0]	Current mode	
[1] *	Voltage mode	

4.7.4 6-7* Analog/Digital Output 45

Parameters for configuring the scaling and limits for analog/digital output terminal 45. Analog outputs are current outputs: 0/4–20 mA. Resolution on analog output is 12 bit. Analog output terminals can also be set up as digital output.

6-70 Terminal 45 Mode		
Option:		Function:
		Set terminal 45 to act as analog output or as digital output.
[0] *	0-20 mA	
[1]	4-20 mA	
[2]	Digital Output	

6-71 Terminal 45 Analog Output		
Option:		Function:
		Select the function of terminal 45 as an analog current output. See also <i>parameter 6-70 Terminal 45 Mode</i> .
[0] *	No operation	

6-71 Terminal 45 Analog Output		
Option:	Function:	
[100]	Output frequency	0–100 Hz
[101]	Reference	Min _{Ref.} –Max _{Ref.}
[102]	Feedback	Min _{FB} –Max _{FB}
[103]	Motor Current	0–I _{max}
[106]	Power	0–P _{nom}
[139]	Bus Control	0–100%

6-72 Terminal 45 Digital Output		
Option:	Function:	
		Select the function of terminal 45 as a digital current output. See also <i>parameter 6-70 Terminal 45 Mode</i> . See <i>parameter 5-40 Function Relay</i> for description of the options.
[0] *	No operation	
[1]	Control Ready	
[2]	Drive ready	
[3]	Drive ready/remote control	
[4]	Standby / no warning	
[5]	Drive running	
[6]	Running / no warning	
[7]	Run in range/no warning	
[8]	Run on ref/no warning	
[9]	Alarm	
[10]	Alarm or warning	
[12]	Out of current range	
[13]	Below current, low	
[14]	Above current, high	
[16]	Below speed, low	
[17]	Above speed, high	
[19]	Below feedback, low	
[20]	Above feedback, high	
[21]	Thermal warning	
[22]	Ready, no thermal warning	
[23]	Remote, ready, no thermal warning	
[24]	Ready, Voltage OK	
[25]	Reverse	
[26]	Bus OK	
[32]	Mech brake ctrl	
[35]	External Interlock	
[36]	Control word bit 11	
[37]	Control word bit 12	
[41]	Below reference, low	
[42]	Above ref, high	
[45]	Bus Control	
[60]	Comparator 0	

6-72 Terminal 45 Digital Output		
Option:	Function:	
[61]	Comparator 1	
[62]	Comparator 2	
[63]	Comparator 3	
[64]	Comparator 4	
[65]	Comparator 5	
[70]	Logic rule 0	
[71]	Logic rule 1	
[72]	Logic rule 2	
[73]	Logic rule 3	
[74]	Logic rule 4	
[75]	Logic rule 5	
[80]	SL digital output A	
[81]	SL digital output B	
[82]	SL digital output C	
[83]	SL digital output D	
[160]	No alarm	
[161]	Running reverse	
[165]	Local ref. active	
[166]	Remote ref. active	
[167]	Start command activ	
[168]	Drive in hand mode	
[169]	Drive in auto mode	
[191]	Dry Pump	
[192]	End Of Curve	
[193]	Sleep Mode	
[194]	Broken Belt Function	
[196]	Fire Mode	
[198]	Drive Bypass	

6-73 Terminal 45 Output Min Scale		
Range:	Function:	
0 %* [0 - 200 %]	Scale for the minimum output (0 mA or 4 mA) of the analog signal at terminal 45. Set the value to be the percentage of the full range of the variable selected in <i>parameter 6-71 Terminal 45 Analog Output</i> .	

6-74 Terminal 45 Output Max Scale		
Range:	Function:	
100 %* [0 - 200 %]	Scale for the maximum output (20 mA) of the analog signal at terminal 45. Set the value to be the percentage of the full range of the variable selected in <i>parameter 6-71 Terminal 45 Analog Output</i> .	

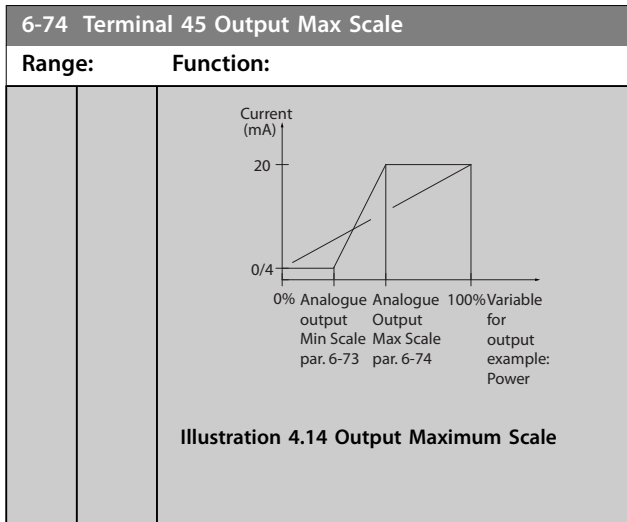

6-76 Terminal 45 Output Bus Control

Range: **Function:**

0*	[0 - 16384]	Holds the level of analog output if controlled by bus.
----	--------------	--

4.7.5 6-9* Analog/Digital Output 42

Parameters for configuring the limits for analog/digital output terminal 42. Analog outputs are current outputs: 0/4–20 mA. Resolution on analog outputs is 12 bit. Analog output terminals can also be set up as digital output.

6-90 Terminal 42 Mode

Option: **Function:**

		Set terminal 42 to act as analog output or as digital output.
[0] *	0-20 mA	
[1]	4-20 mA	
[2]	Digital Output	

6-91 Terminal 42 Analog Output

Option: **Function:**

		Select the function of terminal 42 as an analog current output. See also <i>parameter 6–90 Terminal 42 Mode</i> .
[0] *	No operation	
[100]	Output frequency	0–100 Hz
[101]	Reference	Min _{Ref.} - Max _{Ref.}
[102]	Feedback	Min _{FB} - Max _{FB}
[103]	Motor Current	0–I _{max}
[106]	Power	0–P _{nom}
[139]	Bus Control	0–100%

6-92 Terminal 42 Digital Output

Option: **Function:**

		Select the function of terminal 42 as an analog current output. See also <i>parameter 6–90 Terminal 42 Mode</i> . See <i>parameter 5-40 Function Relay</i> for description of the options.
[0] *	No operation	
[1]	Control Ready	
[2]	Drive ready	
[3]	Drive ready/remote control	
[4]	Standby / no warning	
[5]	Drive running	
[6]	Running / no warning	
[7]	Run in range/no warning	
[8]	Run on ref/no warning	
[9]	Alarm	
[10]	Alarm or warning	
[12]	Out of current range	
[13]	Below current, low	
[14]	Above current, high	
[16]	Below speed, low	
[17]	Above speed, high	
[19]	Below feedback, low	
[20]	Above feedback, high	
[21]	Thermal warning	
[22]	Ready, no thermal warning	
[23]	Remote, ready, no thermal warning	
[24]	Ready, Voltage OK	
[25]	Reverse	
[26]	Bus OK	
[32]	Mech brake ctrl	
[35]	External Interlock	
[36]	Control word bit 11	
[37]	Control word bit 12	
[41]	Below reference, low	
[42]	Above ref, high	
[45]	Bus Control	
[60]	Comparator 0	
[61]	Comparator 1	
[62]	Comparator 2	
[63]	Comparator 3	
[64]	Comparator 4	
[65]	Comparator 5	
[70]	Logic rule 0	
[71]	Logic rule 1	
[72]	Logic rule 2	
[73]	Logic rule 3	
[74]	Logic rule 4	
[75]	Logic rule 5	

6-92 Terminal 42 Digital Output	
Option:	Function:
[80]	SL digital output A
[81]	SL digital output B
[82]	SL digital output C
[83]	SL digital output D
[160]	No alarm
[161]	Running reverse
[165]	Local ref. active
[166]	Remote ref. active
[167]	Start command activ
[168]	Drive in hand mode
[169]	Drive in auto mode
[191]	Dry Pump
[192]	End Of Curve
[193]	Sleep Mode
[194]	Broken Belt Function
[196]	Fire Mode
[198]	Drive Bypass

6-93 Terminal 42 Output Min Scale	
Range:	Function:
0 %* [0 - 200 %]	Scale for the minimum output (0 mA or 4 mA) of the analog signal at terminal 42. Set the value to be the percentage of the full range of the variable selected in <i>parameter 6-91 Terminal 42 Analog Output</i> .

6-94 Terminal 42 Output Max Scale	
Range:	Function:
100 %* [0 - 200 %]	<p>Scale for the maximum output (20 mA) of the scaling at terminal 42. Set the value to be the percentage of the full range of the variable selected in <i>parameter 6-91 Terminal 42 Analog Output</i>.</p> <p>Illustration 4.15 Output Maximum Scale</p>

6-96 Terminal 42 Output Bus Control	
Range:	Function:
0* [0 - 16384]	Holds the analog output at terminal 42 if controlled by bus.

4.8 Main Menu - Communications and Options - Group 8

4.8.1 8-0* General Settings

8-01 Control Site		
Option:	Function:	
		This parameter overrules settings in <i>parameter 8-50 Coasting Select</i> to <i>parameter 8-56 Preset Reference Select</i> .
[0] *	Digital and ctrl.word	Control by using both digital input and control word.
[1]	Digital only	Control by using digital inputs only.
[2]	Controlword only	Control by using control word only.

8-02 Control Source		
Option:	Function:	
		NOTICE This parameter cannot be adjusted while the motor is running. Select the source of the control word.
[0]	None	
[1]	FC Port	
[3]	Option A	PROFIBUS and PROFINET.

8-03 Control Timeout Time		
Range:	Function:	
1 s*	[0.1 - 6000 s]	Enter the maximum time expected to pass between the reception of 2 consecutive telegrams. If this time is exceeded, it indicates that the serial communication has stopped. The function selected in <i>parameter 8-04 Control Timeout Function</i> <i>Control Timeout Function</i> is carried out.

8-04 Control Timeout Function		
Option:	Function:	
		Select the timeout function. The timeout function is activated when the control word fails to be updated within the time period specified in <i>parameter 8-03 Control Timeout Time</i> . Option [20] <i>N2 Override Release</i> only appears after setting the Metasys N2 protocol.
[0] *	Off	
[1]	Freeze output	
[2]	Stop	
[3]	Jogging	
[4]	Max. speed	
[5]	Stop and trip	

8-04 Control Timeout Function		
Option:	Function:	
[20]	N2 Override Release	

8-07 Diagnosis Trigger		
Option:	Function:	
		Select [0] <i>Disable</i> to send no extended diagnosis data (EDD). Select [1] <i>Trigger on alarms</i> to send EDD upon alarms or [2] <i>Trigger alarm/warn.</i> to send EDD upon alarms or warnings. Not all fieldbuses support the diagnosis functions.
[0] *	Disable	
[1]	Trigger on alarms	
[2]	Trigger alarm/warn.	

4.8.2 8-1* Ctrl. Word Settings

8-10 Control Word Profile		
Option:	Function:	
		Select the interpretation of the control and status words corresponding to the installed fieldbus. Only the selections valid for the fieldbus installed in slot A are visible in the LPC display.
[0] *	FC profile	
[1]	PROFdrive profile	

8-14 Configurable Control Word CTW		
Option:	Function:	
[0]	None	The frequency converter ignores the information in this bit.
[1] *	Profile default	The functionality of the bit is depending on the selection <i>parameter 8-10 Control Word Profile</i> .
[2]	CTW Valid, active low	If set to 1, the frequency converter ignores the remaining bits of the control word.

8-19 Product Code		
Range:	Function:	
Size related*	[0 - 2147483647]	Select 0 to readout the actual fieldbus product code according to the mounted fieldbus option. Select 1 to readout the actual vendor ID.

4.8.3 8-3* FC Port Settings

8-30 Protocol		
Option:	Function:	
		Select the protocol for the integrated RS485 port. Change of settings in <i>parameter 8-30 Protocol</i> may change the baud rate.
[0] *	FC	Communication according to the FC Protocol.
[2]	Modbus RTU	Communication according to the Modbus RTU protocol.
[4]	FLN	
[5]	BACNet	

8-31 Address		
Range:	Function:	
1*	[0.0 - 247]	Enter the address for the RS485 port. Valid range: 1–126 for FC-bus, or 1–247 for Modbus.

8-32 Baud Rate		
Option:	Function:	
		Select the baud rate for the RS485 port Default refers to the FC protocol. Changing the protocol in <i>parameter 8-30 Protocol</i> may change the baud rate. Changing protocol in <i>parameter 8-30 Protocol</i> may change the baud rate.
[0]	2400 Baud	
[1]	4800 Baud	Default setting for FLN.
[2]	9600 Baud	Default setting for BACnet.
[3]	19200 Baud	Default setting for Modbus RTU.
[4]	38400 Baud	
[5]	57600 Baud	
[6]	76800 Baud	
[7]	115200 Baud	

8-33 Parity / Stop Bits		
Option:	Function:	
		Parity and stop bits for the protocol using the FC port. For some of the protocols, not all options are available. Default refers to the FC protocol. Changing protocol in <i>parameter 8-30 Protocol</i> may change the baud rate.
[0]	Even Parity, 1 Stop Bit	
[1]	Odd Parity, 1 Stop Bit	
[2]	No Parity, 1 Stop Bit	
[3]	No Parity, 2 Stop Bits	

8-35 Minimum Response Delay		
Range:	Function:	
0.01 s*	[0.0010 - 0.5 s]	Specify the minimum delay time between receiving a request and transmitting a response. This minimum delay time is used for overcoming modem turnaround delays.

8-36 Maximum Response Delay		
Range:	Function:	
Size related*	[0.1 - 10.0 s]	Specify the maximum permissible delay time between receiving a request and transmitting the response. If this time is exceeded, no response is returned.

8-37 Maximum Inter-char delay		
Range:	Function:	
0.025 s*	[0.025 - 0.025 s]	Specify the maximum permissible time interval between receipt of 2 bytes. This parameter activates timeout if transmission is interrupted.

4.8.4 8-4* MC Protocol Set

8-40 Telegram Selection		
Option:	Function:	
		Enables use of freely configurable telegrams or standard telegrams for the FC Port.
[1] *	Standard telegram 1	
[300]	Standard telegram FCM300	

8-42 PCD Write Configuration		
Different parameters can be assigned to PCD 3–10 of the PPOs. The number of PCDs depends on the PPO type. The values in PCD 3–10 are written to the selected parameters as data values.		
Option:	Function:	
[0]	None	
[1]	[302] Minimum Reference	
[2]	[303] Maximum Reference	
[3]	[341] Ramp 1 Ramp up time	
[4]	[342] Ramp 1 Ramp down time	
[5]	[351] Ramp 2 Ramp up time	
[6]	[352] Ramp 2 Ramp down time	
[7]	[380] Jog Ramp Time	
[8]	[381] Quick Stop Time	
[9]	[412] Motor Speed Low Limit [Hz]	
[10]	[414] Motor Speed High Limit [Hz]	

8-42 PCD Write Configuration		
Different parameters can be assigned to PCD 3–10 of the PPOs. The number of PCDs depends on the PPO type. The values in PCD 3–10 are written to the selected parameters as data values.		
Option:	Function:	
[11]	[590] Digital & Relay Bus Control	
[12]	[676] Terminal45 Output Bus Control	
[13]	[696] Terminal 42 Output Bus Control	
[14]	[894] Bus Feedback 1	
[15]	FC Port CTW	
[16]	FC Port REF	

8-43 PCD Read Configuration		
Different parameters can be assigned to PCD 3–10 of the PPOs. The number of PCDs depends on the PPO type. PCD 3–10 hold the real-time data value of the selected parameters.		
Option:	Function:	
[0]	None	
[1]	[1500] Operation Hours	
[2]	[1501] Running Hours	
[3]	[1502] kWh Counter	
[4]	[1600] Control Word	
[5]	[1601] Reference [Unit]	
[6]	[1602] Reference %	
[7]	[1603] Status Word	
[8]	[1605] Main Actual Value [%]	
[9]	[1609] Custom Readout	
[10]	[1610] Power [kW]	
[11]	[1611] Power [hp]	
[12]	[1612] Motor Voltage	
[13]	[1613] Frequency	
[14]	[1614] Motor Current	
[15]	[1615] Frequency [%]	
[16]	[1616] Torque [Nm]	
[17]	[1618] Motor Thermal	
[18]	[1630] DC Link Voltage	
[19]	[1634] Heatsink Temp.	
[20]	[1635] Inverter Thermal	
[21]	[1638] SL Controller State	
[22]	[1650] External Reference	
[23]	[1652] Feedback [Unit]	
[24]	[1660] Digital Input 18,19,27,33	
[25]	[1661] Terminal 53 Switch Setting	
[26]	[1662] Analog Input 53(V)	
[27]	[1663] Terminal 54 Switch Setting	
[28]	[1664] Analog Input 54	
[29]	[1665] Analog Output 42 [mA]	
[30]	[1671] Relay Output [bin]	
[31]	[1672] Counter A	
[32]	[1673] Counter B	

8-43 PCD Read Configuration		
Different parameters can be assigned to PCD 3–10 of the PPOs. The number of PCDs depends on the PPO type. PCD 3–10 hold the real-time data value of the selected parameters.		
Option:	Function:	
[33]	[1690] Alarm Word	
[34]	[1692] Warning Word	
[35]	[1694] Ext. Status Word	
[36]	[1850] Sensorless Readout [Unit]	

4.8.5 8-5* Digital/Bus

Parameters for configuring the control word digital/bus merging.

8-50 Coasting Select		
Option:	Function:	
		NOTICE This parameter is active only when <i>parameter 8-01 Control Site</i> is set to [0] <i>Digital and control word</i> . Select control of the coasting function via the terminals (digital input) and/or via the bus.
[0]	Digital input	Activates coast via a digital input.
[1]	Bus	Activates coast via the serial communication port.
[2]	Logic AND	Activates coast via the fieldbus/serial communication port, and via 1 of the digital inputs.
[3] *	Logic OR	Activates coast via the serial communication port or via 1 of the digital inputs.

8-51 Quick Stop Select		
Option:	Function:	
		NOTICE This parameter is active only when <i>parameter 8-01 Control Site</i> is set to [0] <i>Digital and control word</i> . Select control of the <i>Quick Stop</i> function via the terminals (digital input) and/or via the bus.
[0]	Digital input	Activates quick stop via a digital input.
[1]	Bus	Activates quick stop via the serial communication port.
[2]	Logic AND	Activates quick stop via the serial communication port, and via 1 of the digital inputs.
[3] *	Logic OR	Activates quick stop via the serial communication port or via 1 of the digital inputs.

8-52 DC Brake Select		
Option:	Function:	
		<p>NOTICE This parameter is active only when <i>parameter 8-01 Control Site</i> is set to [0] <i>Digital and control word</i>.</p> <p>Select control of the DC brake via the terminals (digital input).</p>
[0]	Digital input	Activates DC brake via a digital input.
[1]	Bus	Activates DC brake via the serial communication port.
[2]	Logic AND	Activates DC brake via the serial communication port, and via 1 of the digital inputs.
[3]	Logic OR	Activates DC brake via the serial communication port or via 1 of the digital inputs.

8-53 Start Select		
Option:	Function:	
		<p>NOTICE This parameter is active only when <i>parameter 8-01 Control Site</i> is set to [0] <i>Digital and control word</i>.</p> <p>Select control of the frequency converter start function via the terminals (digital input).</p>
[0]	Digital input	Activates a start command via a digital input.
[1]	Bus	Activates a start command via the serial communication port or fieldbus options.
[2]	Logic AND	Activates a start command via the serial communication port, and via 1 of the digital inputs.
[3] *	Logic OR	Activates a start command via the serial communication port or via 1 of the digital inputs.

8-54 Reversing Select		
Option:	Function:	
		<p>NOTICE This parameter is active only when <i>parameter 8-01 Control Site</i> is set to [0] <i>Digital and control word</i>.</p> <p>Select control of the frequency converter <i>Reverse</i> function via the terminals (digital input) and/or via the serial communication port.</p>
[0] *	Digital input	Activates a reverse command via a digital input.
[1]	Bus	Activates a reverse command via the serial communication port.

8-54 Reversing Select		
Option:	Function:	
[2]	Logic AND	Activates a reverse command via the serial communication port, and via 1 of the digital inputs.
[3]	Logic OR	Activates a reverse command via the serial communication port or via 1 of the digital inputs.

8-55 Set-up Select		
Option:	Function:	
		<p>NOTICE This parameter is active only when <i>parameter 8-01 Control Site</i> is set to [0] <i>Digital and control word</i>.</p> <p>Select control of the frequency converter set-up selection via the terminals (digital input) and/or via the serial communication port.</p>
[0]	Digital input	Activates the set-up selection via a digital input.
[1]	Bus	Activates the set-up selection via the serial communication port.
[2]	Logic AND	Activates the set-up selection via the serial communication port, and via 1 of the digital inputs.
[3] *	Logic OR	Activate the set-up selection via the serial communication port or via 1 of the digital inputs.

8-56 Preset Reference Select		
Option:	Function:	
		Select control of the frequency converter preset reference selection via the terminals (digital input) and/or via the serial communication port.
[0]	Digital input	Activates the preset reference selection via a digital input.
[1]	Bus	Activates the preset reference selection via the serial communication port.
[2]	Logic AND	Activates the preset reference selection via the serial communication port, and via 1 of the digital inputs.
[3] *	Logic OR	Activates the preset reference selection via the serial communication port or via 1 of the digital inputs.

8-57 Profidrive OFF2 Select		
Option:	Function:	
[0]	Digital input	

Select control of the frequency converter OFF2 selection via the terminals (digital input) and/or via the fieldbus. This parameter is active only when *parameter 8-01 Control Site* is set to [0] *Digital and ctrl. word*, and *parameter 8-10 Control Word Profile* is set to [1] *Profidrive profile*.

8-57 Profdrive OFF2 Select		
Select control of the frequency converter OFF2 selection via the terminals (digital input) and/or via the fieldbus. This parameter is active only when <i>parameter 8-01 Control Site</i> is set to [0] <i>Digital and ctrl. word</i> , and <i>parameter 8-10 Control Word Profile</i> is set to [1] <i>Profdrive profile</i> .		
Option:	Function:	
[1]	Bus	
[2]	Logic AND	
[3] *	Logic OR	

8-58 Profdrive OFF3 Select		
Select control of the frequency converter OFF3 selection via the terminals (digital input) and/or via the fieldbus. This parameter is active only when <i>parameter 8-01 Control Site</i> is set to [0] <i>Digital and ctrl. word</i> , and <i>parameter 8-10 Control Word Profile</i> is set to [1] <i>Profdrive profile</i> .		
Option:	Function:	
[0]	Digital input	
[1]	Bus	
[2]	Logic AND	
[3] *	Logic OR	

4.8.6 8-7* BACnet

8-70 BACnet Device Instance		
Range:	Function:	
1*	[0 - 4194303]	Enter a unique ID number for the BACnet device.

8-72 MS/TP Max Masters		
Range:	Function:	
127*	[0 - 127]	Define the address of the master, which holds the highest address in this network. Decreasing this value optimizes polling for the token.

8-73 MS/TP Max Info Frames		
Range:	Function:	
1*	[1 - 65534]	Define how many info/data frames the device is allowed to send while holding the token.

8-74 "I am" Service		
Option:	Function:	
[0] *	Send at power-up	Select when the device should send the I-Am service message only at power-up.
[1]	Continuously	Select when the device should send the I-Am service message continuously with an interval of approximately 1 minute.

8-75 Intialisation Password		
Range:	Function:	
admin*	[1 - 1]	Enter the password needed for execution of Drive Re-initialization from BACnet.

8-79 Protocol Firmware version		
Range:	Function:	
Size related*	[0 - 65535]	Read the supported protocol version. Index 5 is for BACnet.

4.8.7 8-8* FC Port Diagnostics

These parameters are used for monitoring the bus communication via the FC port.

8-80 Bus Message Count		
Range:	Function:	
0*	[0 - 4294967295]	This parameter shows the number of valid telegrams detected on the bus.

8-81 Bus Error Count		
Range:	Function:	
0*	[0 - 4294967295]	This parameter shows the number of telegrams with faults (for example, CRC fault), detected on the bus.

8-82 Slave Messages Rcvd		
Range:	Function:	
0*	[0 - 4294967295]	This parameter shows the number of valid telegrams addressed to the slave, sent by the frequency converter.

8-83 Slave Error Count		
Range:	Function:	
0*	[0 - 4294967295]	This parameter shows the number of error telegrams, which the frequency converter could not execute.

8-84 Slave Messages Sent		
Range:	Function:	
0*	[0 - 4294967295]	This parameter shows the number of messages sent from the slave.

8-85 Slave Timeout Errors		
Range:	Function:	
0*	[0 - 4294967295]	This parameter shows the number of slave timeout errors.

8-88 Reset FC port Diagnostics		
Option:	Function:	
[0] *	Do not reset	
[1]	Reset counter	

4.8.8 8-9* Bus Feedback

4

8-90 Bus Jog 1 Speed		
Range:		Function:
100 RPM*	[0 - 1500 RPM]	Enter the jog speed. Activate this fixed jog speed via the serial port or fieldbus option.

8-91 Bus Jog 2 Speed		
Range:		Function:
200 RPM*	[0 - 1500 RPM]	Enter the jog speed. Activate this fixed jog speed via the serial port or fieldbus option.

8-94 Bus Feedback 1		
Range:		Function:
0*	[-32768 - 32767]	Write feedback to this parameter via the serial communication port. Select this parameter in <i>parameter 20-00 Feedback 1 Source</i> or <i>parameter 20-03 Feedback 2 Source</i> as a feedback source. Hex-value 4000 h corresponds to 100% feedback/range is $\pm 200\%$.

4.9 Main Menu - PROFIdrive - Group 9

9-00 Setpoint		
Range:	Function:	
0* [0 - 65535]	This parameter receives cyclic reference from a master class 2. If the control priority is set to master class 2, the reference for the frequency converter is taken from this parameter, whereas the cyclic reference is ignored.	

9-07 Actual Value		
Range:	Function:	
0* [0 - 65535]	This parameter delivers the MAV for a master class 2. The parameter is valid if the control priority is set to master class 2.	

9-15 PCD Write Configuration		
Select the parameters to be assigned to PCD 3–10 of the telegrams. The number of available PCDs depends on the telegram type. Values in PCD 3–10 are written to the selected parameters as data. For standard PROFIBUS telegrams, see <i>parameter 9-22 Telegram Selection</i> .		
Option:	Function:	
[0]		
[302]	Minimum Reference	
[303]	Maximum Reference	
[312]	Catch up/slow Down Value	
[341]	Ramp 1 Ramp Up Time	
[342]	Ramp 1 Ramp Down Time	
[351]	Ramp 2 Ramp Up Time	
[352]	Ramp 2 Ramp Down Time	
[380]	Jog Ramp Time	
[381]	Quick Stop Ramp Time	
[412]	Motor Speed Low Limit [Hz]	
[414]	Motor Speed High Limit [Hz]	
[553]	Term. 29 High Ref./Feedb. Value	
[590]	Digital & Relay Bus Control	
[615]	Terminal 53 High Ref./Feedb. Value	
[625]	Terminal 54 High Ref./Feedb. Value	
[696]	Terminal 42 Output Bus Control	
[890]	Bus Jog 1 Speed	
[891]	Bus Jog 2 Speed	
[894]	Bus Feedback 1	
[1680]	Fieldbus CTW 1	
[1682]	Fieldbus REF 1	
[2021]	Setpoint 1	

9-16 PCD Read Configuration		
Select the parameters to be assigned to PCD 3–10 of the telegrams. The number of available PCDs depends on the telegram type. Values in PCD 3–10 contain the actual data values of the selected parameters.		
Option:	Function:	
[0]		
[894]	Bus Feedback 1	
[1500]	Operating hours	
[1501]	Running Hours	
[1502]	kWh Counter	
[1600]	Control Word	
[1601]	Reference [Unit]	
[1602]	Reference [%]	
[1603]	Status Word	
[1605]	Main Actual Value [%]	
[1609]	Custom Readout	
[1610]	Power [kW]	
[1611]	Power [hp]	
[1612]	Motor Voltage	
[1613]	Frequency	
[1614]	Motor current	
[1615]	Frequency [%]	
[1616]	Torque [Nm]	
[1618]	Motor Thermal	
[1622]	Torque [%]	
[1626]	Power Filtered [kW]	
[1627]	Power Filtered [hp]	
[1630]	DC Link Voltage	
[1634]	Heatsink Temp.	
[1635]	Inverter Thermal	
[1638]	SL Controller State	
[1639]	Control Card Temp.	
[1650]	External Reference	
[1652]	Feedback[Unit]	
[1660]	Digital Input	
[1661]	Terminal 53 Setting	
[1662]	Analog Input AI53	
[1663]	Terminal 54 Setting	
[1664]	Analog Input AI54	
[1665]	Analog Output AO42 [mA]	
[1666]	Digital Output	
[1667]	Pulse Input #29 [Hz]	
[1671]	Relay Output [bin]	
[1672]	Counter A	
[1673]	Counter B	
[1679]	Analog Output AO45	
[1684]	Comm. Option STW	
[1685]	FC Port CTW 1	
[1690]	Alarm Word	
[1691]	Alarm Word 2	
[1692]	Warning Word	
[1693]	Warning Word 2	
[1694]	Ext. Status Word	

9-16 PCD Read Configuration		
Select the parameters to be assigned to PCD 3–10 of the telegrams. The number of available PCDs depends on the telegram type. Values in PCD 3–10 contain the actual data values of the selected parameters.		
Option:		Function:
[1695]	Ext. Status Word 2	
[1697]	Alarm Word 3	
[1850]	Sensorless Readout [unit]	

9-18 Node Address		
Range:		Function:
126*	[0 - 126]	Enter the station address in this parameter or, alternatively, in the hardware switch. To adjust the station address in <i>parameter 9-18 Node Address</i> , set the hardware switch to 126 or 127 (that is all switches set to <i>on</i>). Otherwise, this parameter shows the actual setting of the switch.

9-19 Drive Unit System Number		
Range:		Function:
1038*	[0 - 65535]	Manufacturer-specific system ID.

9-22 Telegram Selection		
Option:		Function:
[1]	Standard telegram 1	Select a standard PROFIBUS telegram configuration for the frequency converter as an alternative to the freely configurable telegrams in <i>parameter 9-15 PCD Write Configuration</i> and <i>parameter 9-16 PCD Read Configuration</i> .
[100] *	None	
[101]	PPO 1	
[102]	PPO 2	
[103]	PPO 3	
[104]	PPO 4	
[105]	PPO 5	
[106]	PPO 6	
[107]	PPO 7	
[108]	PPO 8	
[200]	Custom telegram 1	

9-23 Parameters for Signals		
Option:		Function:
[0] *		
[302]	Minimum Reference	
[303]	Maximum Reference	
[312]	Catch up/slow Down Value	
[341]	Ramp 1 Ramp Up Time	
[342]	Ramp 1 Ramp Down Time	
[351]	Ramp 2 Ramp Up Time	
[352]	Ramp 2 Ramp Down Time	

9-23 Parameters for Signals		
Option:		Function:
[380]	Jog Ramp Time	
[381]	Quick Stop Ramp Time	
[412]	Motor Speed Low Limit [Hz]	
[414]	Motor Speed High Limit [Hz]	
[553]	Term. 29 High Ref./Feedb. Value	
[590]	Digital & Relay Bus Control	
[615]	Terminal 53 High Ref./Feedb. Value	
[625]	Terminal 54 High Ref./Feedb. Value	
[696]	Terminal 42 Output Bus Control	
[890]	Bus Jog 1 Speed	
[891]	Bus Jog 2 Speed	
[894]	Bus Feedback 1	
[1500]	Operating hours	
[1501]	Running Hours	
[1502]	kWh Counter	
[1600]	Control Word	
[1601]	Reference [Unit]	
[1602]	Reference [%]	
[1603]	Status Word	
[1605]	Main Actual Value [%]	
[1609]	Custom Readout	
[1610]	Power [kW]	
[1611]	Power [hp]	
[1612]	Motor Voltage	
[1613]	Frequency	
[1614]	Motor current	
[1615]	Frequency [%]	
[1616]	Torque [Nm]	
[1618]	Motor Thermal	
[1622]	Torque [%]	
[1626]	Power Filtered [kW]	
[1627]	Power Filtered [hp]	
[1630]	DC Link Voltage	
[1634]	Heatsink Temp.	
[1635]	Inverter Thermal	
[1638]	SL Controller State	
[1639]	Control Card Temp.	
[1650]	External Reference	
[1652]	Feedback[Unit]	
[1660]	Digital Input	
[1661]	Terminal 53 Setting	
[1662]	Analog Input AI53	
[1663]	Terminal 54 Setting	
[1664]	Analog Input AI54	
[1665]	Analog Output AO42 [mA]	
[1666]	Digital Output	
[1667]	Pulse Input #29 [Hz]	
[1671]	Relay Output [bin]	
[1672]	Counter A	
[1673]	Counter B	
[1679]	Analog Output AO45	
[1680]	Fieldbus CTW 1	

9-23 Parameters for Signals		
Option:	Function:	
[1682]	Fieldbus REF 1	
[1684]	Comm. Option STW	
[1685]	FC Port CTW 1	
[1690]	Alarm Word	
[1691]	Alarm Word 2	
[1692]	Warning Word	
[1693]	Warning Word 2	
[1694]	Ext. Status Word	
[1695]	Ext. Status Word 2	
[1697]	Alarm Word 3	
[1850]	Sensorless Readout [unit]	
[2021]	Setpoint 1	

9-27 Parameter Edit		
Option:	Function:	
		Parameters can be edited via PROFIBUS, the standard RS485 interface, or the LCP.
[0]	Disabled	Disables editing via PROFIBUS.
[1] *	Enabled	Enables editing via PROFIBUS.

9-28 Process Control		
Option:	Function:	
		Process control (setting of control word, speed reference, and process data) is possible via either PROFIBUS or standard fieldbus, but not both simultaneously. Local control is always possible via the LCP. Control via process control is possible via either terminals or fieldbus depending on the settings in <i>parameter 8-50 Coasting Select</i> to <i>parameter 8-56 Preset Reference Select</i> .
[0]	Disable	Disables process control via PROFIBUS master class 1, and enables process control via standard fieldbus or PROFIBUS master class 2.
[1] *	Enable cyclic master	Enables process control via PROFIBUS master class 1, and disables process control via standard fieldbus or PROFIBUS master class 2.

9-44 Fault Message Counter		
Range:	Function:	
0* [0 - 65535]		Indicates the number of fault events presently stored in <i>parameter 9-45 Fault Code</i> . The buffer capacity is maximum 8 error events. The buffer and counter are set to 0 by reset or power-up.

9-45 Fault Code		
Range:	Function:	
0* [0 - 0]		This buffer contains the alarm word for all alarms and warnings that have occurred since last reset or power-up. The buffer capacity is maximum 8 error events.

9-47 Fault Number		
Range:	Function:	
0* [0 - 0]		This buffer contains the alarm word for all alarms and warnings that have occurred since last reset or power-up. The buffer capacity is maximum 8 error events.

9-52 Fault Situation Counter		
Range:	Function:	
0* [0 - 1000]		Indicates the number of fault events that have occurred since last reset or power-up.

9-53 Profibus Warning Word																																				
Range:	Function:																																			
0* [0 - 65535]		This parameter shows PROFIBUS communication warnings.																																		
	<table border="1"> <thead> <tr> <th>Bit</th> <th>Description</th> </tr> </thead> <tbody> <tr><td>0</td><td>Connection with DP master is lost.</td></tr> <tr><td>1</td><td>Not used.</td></tr> <tr><td>2</td><td>FDL (fieldbus data link layer) is not OK.</td></tr> <tr><td>3</td><td>Clear data command received.</td></tr> <tr><td>4</td><td>Actual value is not updated.</td></tr> <tr><td>5</td><td>Baud rate search.</td></tr> <tr><td>6</td><td>PROFIBUS ASIC is not transmitting.</td></tr> <tr><td>7</td><td>Initializing of PROFIBUS is not OK.</td></tr> <tr><td>8</td><td>Frequency converter is tripped.</td></tr> <tr><td>9</td><td>Internal CAN error.</td></tr> <tr><td>10</td><td>Wrong configuration data from PLC.</td></tr> <tr><td>11</td><td>Wrong ID sent by PLC.</td></tr> <tr><td>12</td><td>Internal fault occurred.</td></tr> <tr><td>13</td><td>Not configured.</td></tr> <tr><td>14</td><td>Timeout active.</td></tr> <tr><td>15</td><td>Warning 34 active.</td></tr> </tbody> </table>	Bit	Description	0	Connection with DP master is lost.	1	Not used.	2	FDL (fieldbus data link layer) is not OK.	3	Clear data command received.	4	Actual value is not updated.	5	Baud rate search.	6	PROFIBUS ASIC is not transmitting.	7	Initializing of PROFIBUS is not OK.	8	Frequency converter is tripped.	9	Internal CAN error.	10	Wrong configuration data from PLC.	11	Wrong ID sent by PLC.	12	Internal fault occurred.	13	Not configured.	14	Timeout active.	15	Warning 34 active.	
Bit	Description																																			
0	Connection with DP master is lost.																																			
1	Not used.																																			
2	FDL (fieldbus data link layer) is not OK.																																			
3	Clear data command received.																																			
4	Actual value is not updated.																																			
5	Baud rate search.																																			
6	PROFIBUS ASIC is not transmitting.																																			
7	Initializing of PROFIBUS is not OK.																																			
8	Frequency converter is tripped.																																			
9	Internal CAN error.																																			
10	Wrong configuration data from PLC.																																			
11	Wrong ID sent by PLC.																																			
12	Internal fault occurred.																																			
13	Not configured.																																			
14	Timeout active.																																			
15	Warning 34 active.																																			
Table 4.7 Bit Definition																																				

9-63 Actual Baud Rate		
Option:	Function:	
		This parameter shows the actual PROFIBUS baud rate. The PROFIBUS master automatically sets the baud rate.
[0]	9,6 kbit/s	
[1]	19,2 kbit/s	
[2]	93,75 kbit/s	
[3]	187,5 kbit/s	
[4]	500 kbit/s	
[6]	1500 kbit/s	
[7]	3000 kbit/s	
[8]	6000 kbit/s	
[9]	12000 kbit/s	
[10]	31,25 kbit/s	

9-63 Actual Baud Rate		
Option:	Function:	
[11]	45,45 kbit/s	
[255] *	No baudrate found	

9-64 Device Identification																																			
Range:	Function:																																		
0*	[0 - 0]	<p>NOTICE This parameter is not visible via LCP.</p> <p>The device identification parameter. The data type is array[n] of unsigned16. The assignment of the first subindexes is defined and shown in <i>Table 4.8</i>.</p> <table border="1"> <thead> <tr> <th>Index</th> <th>Content</th> <th>Value</th> </tr> </thead> <tbody> <tr> <td>0</td> <td>Manufacturer</td> <td>128</td> </tr> <tr> <td>1</td> <td>Device type</td> <td>1</td> </tr> <tr> <td>2</td> <td>Version</td> <td>xxyy</td> </tr> <tr> <td>3</td> <td>Firmware date year</td> <td>yyyy</td> </tr> <tr> <td>4</td> <td>Firmware date month</td> <td>ddmm</td> </tr> <tr> <td>5</td> <td>No. of axes</td> <td>Variable</td> </tr> <tr> <td>6</td> <td>Vendor specific: PB Version</td> <td>xxyy</td> </tr> <tr> <td>7</td> <td>Vendor specific: Database Version</td> <td>xxyy</td> </tr> <tr> <td>8</td> <td>Vendor specific: AOC Version</td> <td>xxyy</td> </tr> <tr> <td>9</td> <td>Vendor specific: MOC Version</td> <td>xxyy</td> </tr> </tbody> </table>	Index	Content	Value	0	Manufacturer	128	1	Device type	1	2	Version	xxyy	3	Firmware date year	yyyy	4	Firmware date month	ddmm	5	No. of axes	Variable	6	Vendor specific: PB Version	xxyy	7	Vendor specific: Database Version	xxyy	8	Vendor specific: AOC Version	xxyy	9	Vendor specific: MOC Version	xxyy
Index	Content	Value																																	
0	Manufacturer	128																																	
1	Device type	1																																	
2	Version	xxyy																																	
3	Firmware date year	yyyy																																	
4	Firmware date month	ddmm																																	
5	No. of axes	Variable																																	
6	Vendor specific: PB Version	xxyy																																	
7	Vendor specific: Database Version	xxyy																																	
8	Vendor specific: AOC Version	xxyy																																	
9	Vendor specific: MOC Version	xxyy																																	

9-65 Profile Number		
Range:	Function:	
0*	[0 - 0]	<p>NOTICE This parameter is not visible via LCP.</p> <p>This parameter contains the profile identification. Byte 1 contains the profile number and byte 2 the version number of the profile.</p>

9-67 Control Word 1		
Range:	Function:	
0*	[0 - 65535]	This parameter accepts the control word from a master class 2 in the same format as PCD 1.

9-68 Status Word 1		
Range:	Function:	
0*	[0 - 65535]	This parameter delivers the status word for a master class 2 in the same format as PCD 2.

9-70 Edit Set-up		
Option:	Function:	
		Select the set-up in which programming (change of data) is performed during operation. It is possible to program the 4 set-ups independently of the set-up selected as active set-up. Parameter access from each master is directed to the set-up selected by the individual master (cyclic, acyclic MCL1, 1st acyclic MCL2, 2nd acyclic MCL2, 3rd acyclic MCL2).
[1]	Set-up 1	
[2]	Set-up 2	
[9] *	Active Set-up	

9-71 Profibus Save Data Values		
Option:	Function:	
		Parameter values changed via RS485 are not automatically stored in a non-volatile memory. Use this parameter to activate a function that stores parameter values in the EEPROM non-volatile memory, so changed parameter values are retained at power-down.
[0] *	Off	Deactivates the non-volatile storage function.
[1]	Store all setups	Stores all parameter values in the set-up selected in <i>parameter 9-70 Edit Set-up</i> in the non-volatile memory. The selection returns to [0] Off when all values are stored.
[2]	Store all setups	Stores all parameter values for all set-ups in the non-volatile memory. The selection returns to [0] Off when all parameter values are stored.

9-72 ProfibusDriveReset		
Option:	Function:	
		<p>NOTICE Resets the VLT® PROFIBUS DP MCA 101 option only.</p>
[0] *	No action	
[1]	Power-on reset	Resets frequency converter after power-up, as for power cycle.
[2]	Power-on reset prep	
[3]	Comm option reset	When reset, the frequency converter disappears from the fieldbus, which may cause a communication error from the master.

9-75 DO Identification		
Range:	Function:	
0*	[0 - 65535]	Provides information about the DO (drive object).

9-80 Defined Parameters (1)		
Range:	Function:	
0* [0 - 9999]	This parameter shows a list of all the defined frequency converter parameters available for PROFIBUS.	

9-81 Defined Parameters (2)		
Range:	Function:	
0* [0 - 9999]	This parameter shows a list of all the defined frequency converter parameters available for PROFIBUS.	

9-82 Defined Parameters (3)		
Range:	Function:	
0* [0 - 9999]	This parameter shows a list of all the defined frequency converter parameters available for PROFIBUS.	

9-83 Defined Parameters (4)		
Range:	Function:	
0* [0 - 9999]	This parameter shows a list of all the defined frequency converter parameters available for PROFIBUS.	

9-84 Defined Parameters (5)		
Range:	Function:	
0* [0 - 9999]	This parameter shows a list of all the defined frequency converter parameters available for PROFIBUS.	

9-85 Defined Parameters (6)		
Range:	Function:	
0* [0 - 9999]	This parameter shows a list of all the defined frequency converter parameters available for PROFIBUS.	

9-90 Changed Parameters (1)		
Range:	Function:	
0* [0 - 9999]	This parameter shows a list of all the frequency converter parameters deviating from default setting.	

9-91 Changed Parameters (2)		
Range:	Function:	
0* [0 - 9999]	This parameter shows a list of all the frequency converter parameters deviating from default setting.	

9-92 Changed Parameters (3)		
Range:	Function:	
0* [0 - 9999]	This parameter shows a list of all the frequency converter parameters deviating from default setting.	

9-93 Changed Parameters (4)		
Range:	Function:	
0* [0 - 9999]	This parameter shows a list of all the frequency converter parameters deviating from default setting.	

9-94 Changed Parameters (5)		
Range:	Function:	
0* [0 - 9999]	This parameter shows a list of all the frequency converter parameters deviating from default setting.	

9-99 Profibus Revision Counter		
Range:	Function:	
0* [0 - 65535]	Readout of revision count.	

4.10 Main Menu - Smart Logic - Group 13

4.10.1 13-** Prog. Features

Smart logic control (SLC) is a sequence of user-defined actions (see *parameter 13-52 SL Controller Action [x]*) executed by the SLC when the SLC evaluates the associated user-defined event (see *parameter 13-51 SL Controller Event [x]*) as true. Events and actions are each numbered and linked in pairs. This means that when [0] event is fulfilled (attains the value true), [0] action is executed. After executing this action, the conditions of [1] event is evaluated and if evaluated true, [1] action is executed, and so on. Only 1 event is evaluated at any time. If an event is evaluated as FALSE, nothing happens (in the SLC) during the current scan interval and no other events are evaluated. This means that when the SLC starts, it evaluates [0] event (and only [0] event) each scan interval. Only when [0] event is evaluated true, the SLC executes [0] action and start evaluating [1] event. It is possible to program from 1–20 events and actions. When the last event/action has been executed, the sequence starts over again from [0] event/[0] action.

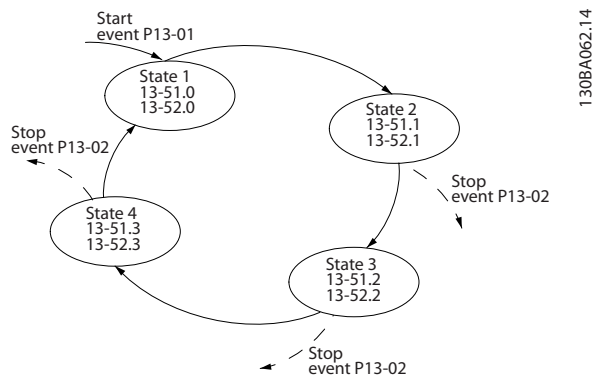

Illustration 4.16 Example with 3 Event/Actions

Starting and stopping the SLC

To start or stop the SLC, select [1] On or [2] Off in *parameter 13-00 SL Controller Mode*. The SLC always starts in state 0 (where it evaluates [0] event). The SLC starts when the start event (defined in *parameter 13-01 Start Event*) is evaluated as true (if [1] On is selected in *parameter 13-00 SL Controller Mode*). The SLC stops when the stop event (*parameter 13-02 Stop Event*) is true. *Parameter 13-03 Reset SLC* resets all SLC parameters and starts programming from the beginning.

4.10.2 13-0* SLC Settings

Use the SLC settings to activate, deactivate, and reset the smart logic control sequence. The logic functions and comparators are always running in the background, which opens for separate control of digital inputs and outputs.

13-00 SL Controller Mode		
Option:	Function:	
		Select [1] On to enable the smart logic control to start when a start command is present, for example, via a digital input. To disable the smart logic control, select [0] Off.
[0] *	Off	Disables the smart logic controller.
[1]	On	Enables the smart logic controller.

13-01 Start Event		
Option:	Function:	
		To activate smart logic control, select the boolean (true or false) input.
[0]	False	Enters the fixed value of false in the logic rule.
[1]	True	Enters the fixed value true in the logic rule.
[2]	Running	The motor runs.
[3]	In range	The motor runs within programmed current ranges (<i>parameter 4-50 Warning Current Low</i> and <i>parameter 4-51 Warning Current High</i>)
[4]	On reference	The motor runs at reference speed.
[7]	Out of current range	The motor current is outside the range set in <i>parameter 4-18 Current Limit</i> .
[8]	Below I low	The motor current is lower than set in <i>parameter 4-50 Warning Current Low</i> .
[9]	Above I high	The motor current is higher than set in <i>parameter 4-51 Warning Current High</i> .
[16]	Thermal warning	The thermal warning turns on when the temperature exceeds the limit in the motor, the frequency converter, or the thermistor.
[17]	Mains out of range	Mains phase loss warning or alarm, if <i>parameter 14-12 Function at Mains Imbalance</i> is not set at [2] Disabled.
[18]	Reversing	The frequency converter reverses.
[19]	Warning	A warning is present.
[20]	Alarm (trip)	An alarm is present.
[21]	Alarm (trip lock)	A trip lock alarm is present.
[22]	Comparator 0	Use the result of comparator 0 in the logic rule.
[23]	Comparator 1	Use the result of comparator 1 in the logic rule.
[24]	Comparator 2	Use the result of comparator 2 in the logic rule.
[25]	Comparator 3	Use the result of comparator 3 in the logic rule.

13-01 Start Event		
Option:	Function:	
[26]	Logic rule 0	Use the result of logic rule 0 in the logic rule.
[27]	Logic rule 1	Use the result of logic rule 1 in the logic rule.
[28]	Logic rule 2	Use the result of logic rule 2 in the logic rule.
[29]	Logic rule 3	Use the result of logic rule 3 in the logic rule.
[33]	Digital input DI18	Use the value of DI18 in the logic rule (High=true).
[34]	Digital input DI19	Use the value of DI19 in the logic rule (High=true).
[35]	Digital input DI27	Use the value of DI27 in the logic rule (High=true).
[36]	Digital input DI29	Use the value of DI29 in the logic rule (High=true).
[39]	Start command *	This event is true if the frequency converter is started (either via digital input, fieldbus or other).
[40]	Drive stopped	This event is true if the frequency converter is stopped or coasted (either via digital input, fieldbus, or other).
[42]	Auto Reset Trip	This event is true if the frequency converter is tripped (but not trip-locked) and an automatic reset is issued.
[50]	Comparator 4	Use the result of comparator 4 in the logic rule.
[51]	Comparator 5	Use the result of comparator 5 in the logic rule.
[60]	Logic rule 4	Use the result of logic rule 4 in the logic rule.
[61]	Logic rule 5	Use the result of logic rule 5 in the logic rule.
[83]	Broken Belt	A broken-belt condition is detected. Enable this function in <i>parameter 22-60 Broken Belt Function</i> .

13-02 Stop Event		
Option:	Function:	
		Select the condition (true or false) which deactivates the smart logic controller.
[0]	False	
[1]	True	
[2]	Running	
[3]	In range	
[4]	On reference	
[7]	Out of current range	

13-02 Stop Event		
Option:	Function:	
[8]	Below I low	
[9]	Above I high	
[16]	Thermal warning	
[17]	Mains out of range	
[18]	Reversing	
[19]	Warning	
[20]	Alarm (trip)	
[21]	Alarm (trip lock)	
[22]	Comparator 0	
[23]	Comparator 1	
[24]	Comparator 2	
[25]	Comparator 3	
[26]	Logic rule 0	
[27]	Logic rule 1	
[28]	Logic rule 2	
[29]	Logic rule 3	
[30]	SL Time-out 0	
[31]	SL Time-out 1	
[32]	SL Time-out 2	
[33]	Digital input DI18	
[34]	Digital input DI19	
[35]	Digital input DI27	
[36]	Digital input DI29	
[39]	Start command	
[40]	Drive stopped *	
[42]	Auto Reset Trip	
[50]	Comparator 4	
[51]	Comparator 5	
[60]	Logic rule 4	
[61]	Logic rule 5	
[70]	SL Time-out 3	
[71]	SL Time-out 4	
[72]	SL Time-out 5	
[73]	SL Time-out 6	
[74]	SL Time-out 7	
[81]	Dry Pump	
[82]	End of Curve	
[83]	Broken Belt	

13-03 Reset SLC		
Option:	Function:	
[0]	Do not reset SLC *	Retains programmed settings in all group 13 parameters (13-** <i>Smart Logic</i>).
[1]	Reset SLC	Resets all group 13 parameters (13-** <i>Smart Logic</i>) to default settings.

4.10.3 13-1* Comparators

Comparators are used for comparing continuous variables (such as output frequency, output current, and analog input) to fixed preset values.

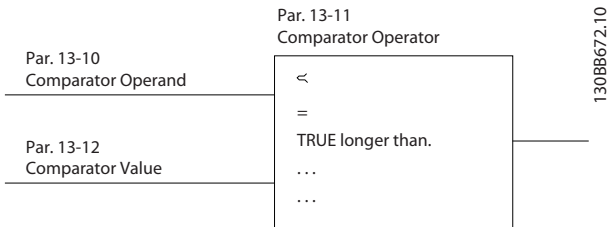

Illustration 4.17 Comparators

In addition, there are digital values that are compared to fixed time values. See the explanation in *parameter 13-10 Comparator Operand*. Comparators are evaluated once in each scan interval. Use the result (true or false) directly. All parameters in this parameter group are array parameters with index 0–5. Select index 0 to program comparator 0, select index 1 to program comparator 1, and so on.

13-10 Comparator Operand		
Array [6]		
Option:	Function:	
		Select the variable to be monitored by the comparator.
[0] *	Disabled	
[1]	Reference %	
[2]	Feedback %	
[3]	Motor speed	
[4]	Motor Current	
[6]	Motor power	
[7]	Motor voltage	
[12]	Analog input AI53	
[13]	Analog input AI54	
[18]	Pulse input FI29	
[20]	Alarm number	
[30]	Counter A	
[31]	Counter B	

13-11 Comparator Operator		
Array [6]		
Option:	Function:	
[0]	Less Than (<)	Select [0] < for the result of the evaluation to be true, when the variable selected in <i>parameter 13-10 Comparator Operand</i> is smaller than the fixed value in <i>parameter 13-12 Comparator Value</i> . The result is false, if the variable selected in <i>parameter 13-10 Comparator Operand</i> is

13-11 Comparator Operator		
Array [6]		
Option:	Function:	
		greater than the fixed value in <i>parameter 13-12 Comparator Value</i> .
[1] *	Approx.Equal (~)	Select [1] ≈ for the result of the evaluation to be true, when the variable selected in <i>parameter 13-10 Comparator Operand</i> is approximately equal to the fixed value in <i>parameter 13-12 Comparator Value</i> .
[2]	Greater Than (>)	Select [2] > for the inverse logic of option [0] <.

13-12 Comparator Value		
Array [6]		
Range:	Function:	
0*	[-9999 - 9999]	Enter the trigger level for the variable that is monitored by this comparator. This parameter is an array parameter containing comparator values 0–5.

4.10.4 13-2* Timers

Use the result (true or false) from timers directly to define an event (see *parameter 13-51 SL Controller Event*), or as boolean input in a logic rule (see *parameter 13-40 Logic Rule Boolean 1*, *parameter 13-42 Logic Rule Boolean 2*, or *parameter 13-44 Logic Rule Boolean 3*). A timer is only false when started by an action (for example [29] *Start timer 1*) until the timer value entered in this parameter is elapsed. Then it becomes true again.

All parameters in this parameter group are array parameters with index 0–2. Select index 0 to program timer 0, select index 1 to program timer 1, and so on.

13-20 SL Controller Timer		
Array [8]		
Range:	Function:	
0 s*	[0 - 3600 s]	Enter the value to define the duration of the false output from the programmed timer. A timer is only false if it is started by an action (see <i>parameter 13-52 SL Controller Action [29–31]</i> and <i>parameter 13-52 SL Controller Action [70–74]</i> Start timer X) and until the timer value has elapsed. Array parameters contain timers 0–7.

4.10.5 13-4* Logic Rules

Combine up to 3 boolean inputs (true/false inputs) from timers, comparators, digital inputs, status bits, and events using the logical operators AND, OR, and NOT. Select boolean inputs for the calculation in *parameter 13-40 Logic Rule Boolean 1*, *parameter 13-42 Logic Rule Boolean 2*, and

parameter 13-44 Logic Rule Boolean 3. Define the operators used to combine the selected inputs logically in parameter 13-41 Logic Rule Operator 1, and parameter 13-43 Logic Rule Operator 2.

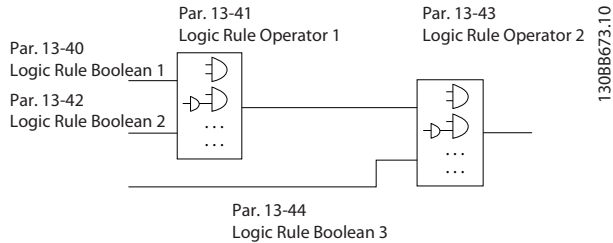

Illustration 4.18 Logic Rules

Priority of calculation

The results of parameter 13-40 Logic Rule Boolean 1, parameter 13-41 Logic Rule Operator 1, and parameter 13-42 Logic Rule Boolean 2 are calculated first. The outcome (true/false) of this calculation is combined with the settings of parameter 13-43 Logic Rule Operator 2 and parameter 13-44 Logic Rule Boolean 3, yielding the final result (true/false) of the logic rule.

13-40 Logic Rule Boolean 1		
Array [6]		
Option:	Function:	
[0] *	False	
[1]	True	
[2]	Running	
[3]	In range	
[4]	On reference	
[7]	Out of current range	
[8]	Below I low	
[9]	Above I high	
[16]	Thermal warning	
[17]	Mains out of range	
[18]	Reversing	
[19]	Warning	
[20]	Alarm (trip)	
[21]	Alarm (trip lock)	
[22]	Comparator 0	
[23]	Comparator 1	
[24]	Comparator 2	
[25]	Comparator 3	
[26]	Logic rule 0	
[27]	Logic rule 1	
[28]	Logic rule 2	
[29]	Logic rule 3	
[30]	SL Time-out 0	
[31]	SL Time-out 1	
[32]	SL Time-out 2	
[33]	Digital input DI18	
[34]	Digital input DI19	
[35]	Digital input DI27	

13-40 Logic Rule Boolean 1		
Array [6]		
Option:	Function:	
[36]	Digital input DI29	
[39]	Start command	
[40]	Drive stopped	
[42]	Auto Reset Trip	
[50]	Comparator 4	
[51]	Comparator 5	
[60]	Logic rule 4	
[61]	Logic rule 5	
[70]	SL Time-out 3	
[71]	SL Time-out 4	
[72]	SL Time-out 5	
[73]	SL Time-out 6	
[74]	SL Time-out 7	
[81]	Dry Pump	
[82]	End of Curve	
[83]	Broken Belt	

13-41 Logic Rule Operator 1		
Option:	Function:	
[0] *	Disabled	
[1]	AND	
[2]	OR	
[3]	AND NOT	
[4]	OR NOT	
[5]	NOT AND	
[6]	NOT OR	
[7]	NOT AND NOT	
[8]	NOT OR NOT	

13-42 Logic Rule Boolean 2		
Array [6]		
Option:	Function:	
		Select the 2nd boolean (true or false) input for the selected logic rule. See parameter 13-40 Logic Rule Boolean 1 for further descriptions of options and their functions.
[0] *	False	
[1]	True	
[2]	Running	
[3]	In range	
[4]	On reference	
[7]	Out of current range	
[8]	Below I low	
[9]	Above I high	
[16]	Thermal warning	
[17]	Mains out of range	
[18]	Reversing	
[19]	Warning	
[20]	Alarm (trip)	
[21]	Alarm (trip lock)	

13-42 Logic Rule Boolean 2		
Array [6]		
Option:	Function:	
[22]	Comparator 0	
[23]	Comparator 1	
[24]	Comparator 2	
[25]	Comparator 3	
[26]	Logic rule 0	
[27]	Logic rule 1	
[28]	Logic rule 2	
[29]	Logic rule 3	
[30]	SL Time-out 0	
[31]	SL Time-out 1	
[32]	SL Time-out 2	
[33]	Digital input DI18	
[34]	Digital input DI19	
[35]	Digital input DI27	
[36]	Digital input DI29	
[39]	Start command	
[40]	Drive stopped	
[42]	Auto Reset Trip	
[50]	Comparator 4	
[51]	Comparator 5	
[60]	Logic rule 4	
[61]	Logic rule 5	
[70]	SL Time-out 3	
[71]	SL Time-out 4	
[72]	SL Time-out 5	
[73]	SL Time-out 6	
[74]	SL Time-out 7	
[81]	Dry Pump	
[82]	End of Curve	
[83]	Broken Belt	

13-43 Logic Rule Operator 2		
Array [6]		
Option:	Function:	
[0] *	Disabled	Select the 2nd logical operator to be used on the boolean input calculated in <i>parameter 13-40 Logic Rule Boolean 1</i> , <i>parameter 13-41 Logic Rule Operator 1</i> , and <i>parameter 13-42 Logic Rule Boolean 2</i> , and the boolean input coming from <i>parameter 13-42 Logic Rule Boolean 2</i> . [13-44] signifies the boolean input of <i>parameter 13-44 Logic Rule Boolean 3</i> . [13-40/13-42] signifies the boolean input calculated in <i>parameter 13-40 Logic Rule Boolean 1</i> , <i>parameter 13-41 Logic Rule Operator 1</i> , and <i>parameter 13-42 Logic Rule Boolean 2</i> . [0] Disabled (factory setting): Select this option to ignore <i>parameter 13-44 Logic Rule Boolean 3</i> .

13-43 Logic Rule Operator 2		
Array [6]		
Option:	Function:	
[1]	AND	
[2]	OR	
[3]	AND NOT	
[4]	OR NOT	
[5]	NOT AND	
[6]	NOT OR	
[7]	NOT AND NOT	
[8]	NOT OR NOT	

13-44 Logic Rule Boolean 3		
Array [6]		
Option:	Function:	
		Select the 3rd boolean (true or false) input for the selected logic rule. See <i>parameter 13-40 Logic Rule Boolean 1</i> for further descriptions of options and their functions.
[0] *	False	
[1]	True	
[2]	Running	
[3]	In range	
[4]	On reference	
[7]	Out of current range	
[8]	Below I low	
[9]	Above I high	
[16]	Thermal warning	
[17]	Mains out of range	
[18]	Reversing	
[19]	Warning	
[20]	Alarm (trip)	
[21]	Alarm (trip lock)	
[22]	Comparator 0	
[23]	Comparator 1	
[24]	Comparator 2	
[25]	Comparator 3	
[26]	Logic rule 0	
[27]	Logic rule 1	
[28]	Logic rule 2	
[29]	Logic rule 3	
[30]	SL Time-out 0	
[31]	SL Time-out 1	
[32]	SL Time-out 2	
[33]	Digital input DI18	
[34]	Digital input DI19	
[35]	Digital input DI27	
[36]	Digital input DI29	
[39]	Start command	
[40]	Drive stopped	
[42]	Auto Reset Trip	
[50]	Comparator 4	

13-44 Logic Rule Boolean 3		
Array [6]		
Option:	Function:	
[51]	Comparator 5	
[60]	Logic rule 4	
[61]	Logic rule 5	
[70]	SL Time-out 3	
[71]	SL Time-out 4	
[72]	SL Time-out 5	
[73]	SL Time-out 6	
[74]	SL Time-out 7	
[81]	Dry Pump	
[82]	End of Curve	
[83]	Broken Belt	

4.10.6 13-5* States

13-51 SL Controller Event		
Array [20]		
Option:	Function:	
		Select the boolean input (true or false) to define the smart logic controller event. See <i>parameter 13-02 Stop Event</i> for further descriptions of options and their functions.
[0] *	False	
[1]	True	
[2]	Running	
[3]	In range	
[4]	On reference	
[7]	Out of current range	
[8]	Below I low	
[9]	Above I high	
[16]	Thermal warning	
[17]	Mains out of range	
[18]	Reversing	
[19]	Warning	
[20]	Alarm (trip)	
[21]	Alarm (trip lock)	
[22]	Comparator 0	
[23]	Comparator 1	
[24]	Comparator 2	
[25]	Comparator 3	
[26]	Logic rule 0	
[27]	Logic rule 1	
[28]	Logic rule 2	
[29]	Logic rule 3	
[30]	SL Time-out 0	
[31]	SL Time-out 1	
[32]	SL Time-out 2	
[33]	Digital input DI18	
[34]	Digital input DI19	

13-51 SL Controller Event		
Array [20]		
Option:	Function:	
[35]	Digital input DI27	
[36]	Digital input DI29	
[39]	Start command	
[40]	Drive stopped	
[42]	Auto Reset Trip	
[50]	Comparator 4	
[51]	Comparator 5	
[60]	Logic rule 4	
[61]	Logic rule 5	
[70]	SL Time-out 3	
[71]	SL Time-out 4	
[72]	SL Time-out 5	
[73]	SL Time-out 6	
[74]	SL Time-out 7	
[81]	Dry Pump	
[82]	End of Curve	
[83]	Broken Belt	

13-52 SL Controller Action		
Array [20]		
Option:	Function:	
		Select the action corresponding to the SLC event. Actions are executed when the corresponding event (defined in <i>parameter 13-51 SL Controller Event</i>) is evaluated as true. The following actions are available for selection:
[0] *	Disabled	
[1]	No action	
[2]	Select set-up 1	Changes the active set-up (<i>parameter 0-10 Active Set-up</i>) to set-up 1.
[3]	Select set-up 2	Changes the active set-up (<i>parameter 0-10 Active Set-up</i>) to set-up 2.
[10]	Select preset ref 0	Selects preset reference 0.
[11]	Select preset ref 1	Selects preset reference 1.
[12]	Select preset ref 2	Selects preset reference 2.
[13]	Select preset ref 3	Selects preset reference 3.
[14]	Select preset ref 4	Selects preset reference 4.
[15]	Select preset ref 5	Selects preset reference 5.
[16]	Select preset ref 6	Selects preset reference 6.
[17]	Select preset ref 7	Selects preset reference 7. If the active preset reference is changed, it merges with other preset reference commands

13-52 SL Controller Action		
Array [20]		
Option:	Function:	
		coming from either the digital inputs or via a fieldbus.
[18]	Select ramp 1	Selects ramp 1.
[19]	Select ramp 2	Selects ramp 2.
[22]	Run	Issues a start command to the frequency converter.
[23]	Run reverse	Issues a start reverse command to the frequency converter.
[24]	Stop	Issues a stop command to the frequency converter.
[25]	Qstop	Issues a quick stop command to the frequency converter.
[26]	DC Brake	Issues a DC stop command to the frequency converter.
[27]	Coast	The frequency converter coasts immediately. All stop commands including the coast command stop the SLC.
[28]	Freeze output	Freezes the output frequency of the frequency converter.
[29]	Start timer 0	Starts timer 0, see <i>parameter 13-20 SL Controller Timer</i> for further description.
[30]	Start timer 1	Starts timer 1, see <i>parameter 13-20 SL Controller Timer</i> for further description.
[31]	Start timer 2	Starts timer 2, see <i>parameter 13-20 SL Controller Timer</i> for further description.
[32]	Set digital out A low	Any output with <i>digital output 1</i> selected is low (off).
[33]	Set digital out B low	Any output with <i>digital output 2</i> selected is low (off).
[34]	Set digital out C low	Any output with <i>digital output 3</i> selected is low (off).
[35]	Set digital out D low	Any output with <i>digital output 4</i> selected is low (off).
[38]	Set digital out A high	Any output with <i>digital output 1</i> selected is high (closed).
[39]	Set digital out B high	Any output with <i>digital output 2</i> selected is high (closed).
[40]	Set digital out C high	Any output with <i>digital output 3</i> selected is high (closed).
[41]	Set digital out D high	Any output with <i>digital output 4</i> selected is high (closed).
[60]	Reset Counter A	Resets counter A to 0.
[61]	Reset Counter B	Resets counter B to 0.

13-52 SL Controller Action		
Array [20]		
Option:	Function:	
[70]	Start Timer 3	Starts timer 3, see <i>parameter 13-20 SL Controller Timer</i> for further description.
[71]	Start Timer 4	Starts timer 4, see <i>parameter 13-20 SL Controller Timer</i> for further description.
[72]	Start Timer 5	Starts timer 5, see <i>parameter 13-20 SL Controller Timer</i> for further description.
[73]	Start Timer 6	Starts timer 6, see <i>parameter 13-20 SL Controller Timer</i> for further description.
[74]	Start Timer 7	Starts timer 7, see <i>parameter 13-20 SL Controller Timer</i> for further description.

4.11 Main Menu - Special Functions - Group 14

4.11.1 14-0* Inverter Switching

14-01 Switching Frequency		
Option:	Function:	
		<p>Select the inverter switching frequency. Changing the switching frequency can help to reduce acoustic noise from the motor.</p> <p>NOTICE The output frequency value of the frequency converter must never exceed 1/10 of the switching frequency. When the motor runs, adjust the switching frequency in <i>parameter 14-01 Switching Frequency</i> until the motor is as quiet as possible.</p> <p>NOTICE High switching frequencies increase heat generation in the frequency converter and may reduce its lifetime.</p> <p>NOTICE Not all options are available in all power sizes.</p>
[0]	Ran3	3 kHz true random PWM (White noise modulation).
[1]	Ran5	5 kHz true random PWM (white noise modulation).
[2]	2.0 kHz	
[3]	3.0 kHz	
[4]	4.0 kHz	
[5]	5.0 kHz	
[6]	6.0 kHz	
[7]	8.0 kHz	
[8]	10.0 kHz	
[9]	12.0 kHz	
[10]	16.0 kHz	

14-03 Overmodulation		
Option:	Function:	
[0] *	Off	Selects no overmodulation of the output voltage to avoid torque ripple on the motor shaft.
[1]	On	The overmodulation function generates an extra voltage of up to 8% of U_{max} output voltage without overmodulation. This extra voltage results in an extra torque of 10–12% in the middle of the oversynchronous range (from 0% at nominal speed, rising to approximately 12% at double nominal speed).

14-07 Dead Time Compensation Level		
Range:	Function:	
Size related*	[0 - 100]	Level of applied deadtime compensation in percentage. A high level (>90%) optimizes the dynamic motor response, a level of 50–90% is good for both motor-torque-ripple minimization and the motor dynamics, a 0 level turns off the deadtime compensation.

14-08 Damping Gain Factor		
Range:	Function:	
Size related*	[0 - 100 %]	Damping factor for DC-link voltage compensation.

14-09 Dead Time Bias Current Level		
Range:	Function:	
Size related*	[0 - 100 %]	To add to the current-sense signal for dead time compensation for some motors, set a bias signal (in percentage).

4.11.2 14-1* Mains On/Off

Parameters for configuring mains failure monitoring and handling.

14-10 Function at Mains Imbalance		
Option:	Function:	
		This parameter tells the frequency converter what to do if mains voltage drops below the limit set in <i>parameter 14-11 Mains Voltage at Mains Fault</i> .
[0] *	No function	
[3]	Coasting	

14-11 Mains Voltage at Mains Fault		
Range:	Function:	
Size related*	[100 - 800 V]	This parameter defines at which AC voltage the selected function in <i>parameter 14-10 Mains Failure</i> must be activated.

14-12 Function at Mains Imbalance		
Option:	Function:	
		<p>NOTICE</p> <p>Selecting this option may reduce the life time of the frequency converter.</p> <p>Operation under severe mains imbalance conditions reduces the lifetime of the motor. If the motor is operated continuously near nominal load, conditions are considered severe. When a severe mains imbalance is detected, select 1 of the available functions.</p>
[0] *	Trip	Trips the frequency converter.
[1]	Warning	Issues a warning.
[2]	Disabled	No action.

4.11.3 14-2* Trip Reset

14-20 Reset Mode		
Option:	Function:	
		<p>NOTICE</p> <p>Automatic reset is also active for resetting the Safe Torque Off function.</p> <p>Select the reset function after tripping. Once reset, the frequency converter can be restarted.</p>
[0] *	Manual reset	Select [0] <i>Manual reset</i> , to perform a reset via [Reset] or via the digital inputs.
[1]	Automatic reset x 1	Select [1]-[12] <i>Automatic reset x 1...x20</i> to perform between 1 and 20 automatic resets after tripping.
[2]	Automatic reset x 2	
[3]	Automatic reset x 3	
[4]	Automatic reset x 4	
[5]	Automatic reset x 5	
[6]	Automatic reset x 6	
[7]	Automatic reset x 7	
[8]	Automatic reset x 8	
[9]	Automatic reset x 9	
[10]	Automatic reset x 10	
[11]	Automatic reset x 15	
[12]	Automatic reset x 20	
[13]	Infinite auto reset	Select [13] <i>Infinite Automatic Reset</i> for continuous resetting after tripping.

14-21 Automatic Restart Time		
Range:	Function:	
10 s* [0 - 600 s]	To start of the automatic reset function, enter the time interval from trip. This parameter is active when <i>parameter 14-20 Reset Mode</i> is set to [1] - [13] <i>Automatic reset</i> .	

14-22 Operation Mode		
Option:	Function:	
		To reset all parameter values to default, select [2] <i>initialization</i> .
[0] *	Normal operation	Select [0] <i>Normal operation</i> for normal operation of the frequency converter with the motor in the selected application.
[2]	Initialisation	Select [2] <i>initialization</i> to reset all parameter values to default settings, excluding bus communication parameters, parameter groups 15-0* <i>Operating Data</i> and 15-3* <i>Alarm Log</i> . The frequency converter is reset during the next power-up. <i>Parameter 14-22 Operation Mode</i> also reverts to the default setting [0] <i>Normal operation</i> .

14-27 Action At Inverter Fault		
Option:	Function:	
Select how the frequency converter acts in the case of overvoltage, overcurrent, short circuit, or grounding errors.		
[0]	Trip	
[1] *	Warning	

14-28 Production Settings		
Option:	Function:	
[0] *	No action	
[1]	Service reset	
[3]	Software Reset	

14-29 Service Code		
Range:	Function:	
0*	[0 - 0x7FFFFFFF]	Service use only.

4.11.4 14-3* Current Limit Control

The frequency converter features an integral current limit controller which is activated when the motor current, and thus the torque, is higher than the torque limits set in *parameter 4-16 Torque Limit Motor Mode* and *parameter 4-17 Torque Limit Generator Mode*.

When the current limit is reached during motor operation or regenerative operation, the frequency converter tries to reduce torque below the preset torque limits as quickly as possible without losing control of the motor.

While the current control is active, the frequency converter can only be stopped by setting a digital input to [2] *Coast inverse* or [3] *Coast and reset inv*. Any signal on terminals 18

to 33 are not active until the frequency converter is no longer near the current limit.

By using a digital input set to [2] *Coast inverse* or [3] *Coast and reset inv.*, the motor does not use the ramp down time, since the frequency converter is coasted.

14-30 Current Lim Ctrl, Proportional Gain		
Range:		Function:
100 %*	[0 - 500 %]	Enter the proportional gain value for the current limit controller. Selection of a high value makes the controller react faster. Too high a setting leads to controller instability.

14-31 Current Lim Ctrl, Integration Time		
Range:		Function:
Size related*	[0.002 - 2 s]	Controls the current limit control integration time. Setting it to a lower value makes it react faster. A setting too low leads to control instability.

14-32 Current Lim Ctrl, Filter Time		
Range:		Function:
Size related*	[1 - 100 ms]	Sets a time constant for the current limit controller low-pass filter.

4.11.5 14-4* Energy Optimization

Parameters for adjusting the energy optimization level in both variable torque (VT) and automatic energy optimization (AEO) mode.

Automatic energy optimization is only active if *parameter 1-03 Torque Characteristics*, is set for [3] *Auto Energy Optim.*

14-40 VT Level		
Range:		Function:
90 %*	[40 - 90 %]	NOTICE This parameter cannot be adjusted while the motor runs. Enter the level of motor magnetization at low speed. Selection of a low value reduces energy loss in the motor, but also reduces load capability.

14-41 AEO Minimum Magnetisation		
Range:		Function:
66 %*	[40 - 75 %]	Enter the minimum allowable magnetization for AEO. Selection of a low value reduces energy loss in the motor, but can also reduce resistance to sudden load changes.

14-44 d-axis current optimization for IPM		
Range:		Function:
100 %*	[0 - 200 %]	This parameter is available only when <i>parameter 1-10 Motor Construction</i> is set to [2] <i>PM, salient IPM, non-Sat.</i> Normally VVC+ PM control automatically optimizes d-axis demagnetizing current based on d-axis and q-axis settings. When <i>parameter 1-10 Motor Construction</i> is set to [2] <i>PM, salient IPM, non-Sat</i> , use this parameter to compensate the saturation effect at high load. Usually, decreasing this value improves the efficiency. However, 0% means no optimization and the d-axis current is zero (not recommended).

4.11.6 14-5* Environment

These parameters help the frequency converter to operate under special environmental conditions.

14-51 DC-Link Voltage Compensation		
Option:	Function:	
[0]	Off	The overmodulation for output voltage is off to avoid torque ripple on the motor shaft.
[1] *	On	Enables the overmodulation for output voltage to obtain an output voltage up to 15% greater than the mains voltage.

14-55 Output Filter		
Select whether an output filter is present.		
Option:	Function:	
[0] *	No Filter	
[1]	Sine-Wave Filter	
[3]	Sine-Wave Filter with Feedback	

4.11.7 14-6* Auto Derate

This group contains parameters for automatic derating of the output current of the frequency converter.

14-61 Function at Inverter Overload		
Is used if there is steady overload beyond the thermal limits (110% for 60 s).		
Option:	Function:	
[0] *	Trip	The frequency converter trips and issues an alarm.
[1]	Derate	Reduces pump speed to decrease the load on the power section, allowing this to cool down.

14-63 Min Switch Frequency

Set the minimum switching frequency allowed by the output filter.

Option:	Function:	
[2] *	2.0 kHz	
[3]	3.0 kHz	
[4]	4.0 kHz	
[5]	5.0 kHz	
[6]	6.0 kHz	
[7]	8.0 kHz	
[8]	10.0 kHz	
[9]	12.0 kHz	
[10]	16.0 kHz	

14-64 Dead Time Compensation Zero Current Level

For a long motor cable, set this parameter to [0] Disabled to minimize the motor-torque ripple.

Option:	Function:	
[0] *	Disabled	
[1]	Enabled	

14-65 Speed Derate Dead Time Compensation

Range:	Function:	
Size related* [20 - 1000 Hz]	Deadtime compensation level is reduced linearly in relation to output frequency. <i>Parameter 14-07 Dead Time Compensation Level</i> sets the maximum level. The minimum output frequency level is defined in <i>parameter 14-65 Speed Derate Dead Time Compensation</i> .	

4.11.8 14-8* Options
14-89 Option Detection

Selects the behavior when an option change is detected. This parameter returns to [0] Protect Option Config. after an option change.

Option:	Function:	
[0] *	Protect Option Config.	Freezes the current settings and prevents unwanted changes when missing or defective options are detected.
[1]	Enable Option Change	Settings can be changed when the system configuration is being modified.

4.11.9 14-9* Fault Settings

Fault customization settings

14-90 Fault Level

Use this parameter to customize fault levels. Setting the parameter value may change *parameter 1-73 Flying Start*.

Option:	Function:	
[3] *	Trip lock	
[4]	Trip with delayed reset	
[5]	Flystart	

4.12 Main Menu - Drive Information - Group 15

Parameter group containing frequency converter information such as operating data, hardware configuration, and software versions.

4.12.1 15-0* Operating Data

15-00 Operating hours		
Range:	Function:	
0 h* [0 - 0x7ffffff. h]	View how many hours the frequency converter has run. The value is saved when the frequency converter is turned off.	

15-01 Running Hours		
Range:	Function:	
0 h* [0 - 0x7ffffff. h]	View how many hours the motor has run. Reset the counter in <i>parameter 15-07 Reset Running Hours Counter</i> . The value is saved when the frequency converter is turned off.	

15-02 kWh Counter		
Range:	Function:	
0 kWh* [0 - 2147483647 kWh]	View the output power of the frequency converter in kWh as an average value over 1 hour. Reset the counter in <i>parameter 15-06 Reset kWh Counter</i> .	

15-03 Power Up's		
Range:	Function:	
0* [0 - 2147483647]	View the number of times the frequency converter has been powered up.	

15-04 Over Temp's		
Range:	Function:	
0* [0 - 65535]	View the number of frequency converter temperature faults that have occurred.	

15-05 Over Volt's		
Range:	Function:	
0* [0 - 65535]	View the number of frequency converter overvoltages that have occurred.	

15-06 Reset kWh Counter		
Option:	Function:	
	NOTICE To reset, press [OK] .	
[0] *	Do not reset	

15-06 Reset kWh Counter		
Option:	Function:	
[1]	Reset counter	To reset the kWh counter to 0, select [1] <i>Reset</i> and press [OK] (see <i>parameter 15-02 kWh Counter</i>).

15-07 Reset Running Hours Counter		
Option:	Function:	
[0] *	Do not reset	
[1]	Reset counter	To reset the running hours counter to 0, select [1] <i>Reset</i> and press [OK] (see <i>parameter 15-01 Running Hours</i>). This parameter cannot be selected via the serial port, RS485. Select [0] <i>Do not reset</i> if no reset of the running-hours counter is required.

4.12.2 15-3* Alarm Log

Parameters in this group are array parameters, where up to 10 fault logs can be viewed. [0] is the most recent logged data, and [9] the oldest. Fault codes, values, and time stamp can be viewed for all logged data.

15-30 Alarm Log: Error Code		
Range:	Function:	
0* [0 - 255]	View the fault code and look up its meaning in <i>chapter 5 Diagnostics and Troubleshooting</i> .	

15-31 InternalFaultReason		
Range:	Function:	
0* [-32767 - 32767]	View a description of the error. This parameter is used with <i>alarm 38, Internal fault</i> .	

4.12.3 15-4* Drive Identification

Parameters containing read-only information about the hardware and software configuration of the frequency converter.

15-40 FC Type		
Range:	Function:	
0* [0 - 6]	View the FC type code. The readout is identical to the frequency converter series power field of the type code definition, characters 1-6.	

15-41 Power Section		
Range:	Function:	
0* [0 - 20]	View the FC type code. The readout is identical to the frequency converter series power field of the type code definition, characters 7-10.	

15-42 Voltage		
Range:	Function:	
0*	[0 - 20]	View the FC type code.The readout is identical to the frequency converter series power field of the type code definition, characters 11–12.

15-43 Software Version		
Range:	Function:	
0*	[0 - 0]	View the software version of the frequency converter.

15-44 Ordered TypeCode		
Range:	Function:	
0*	[0 - 40]	View the type code string used for reordering the frequency converter in its original configuration.

15-45 Actual Typecode String		
Range:	Function:	
0*	[0 - 40]	View the actual type code string.

15-46 Drive Ordering No		
Range:	Function:	
0*	[0 - 8]	View the 8-digit ordering number used for reordering the frequency converter in its original configuration.

15-48 LCP Id No		
Range:	Function:	
0*	[0 - 0]	View the LCP ID number.

15-49 SW ID Control Card		
Range:	Function:	
0*	[0 - 0]	View the control card software version number.

15-50 SW ID Power Card		
Range:	Function:	
0*	[0 - 0]	View the power card software version number.

15-51 Drive Serial Number		
Range:	Function:	
0*	[0 - 10]	View the frequency converter serial number.

15-52 OEM Information		
Range:	Function:	
0*	[0 - 0]	View the OEM Information. The information is set in set-up software MCT 21. [0] OEM Name [1] OEM Type Code [2] OEM Identification number [3] OEM Serial Number

15-53 Power Card Serial Number		
Range:	Function:	
0*	[0 - 0]	View the power card serial number.

15-57 File Version		
Range:	Function:	
0*	[0 - 255]	View file version. The file version is set in set-up software MCT21. [0] OEM-SIVP File Version [1] Motor Database File Version [2] Pump Table File Version

15-59 Filename		
Range:	Function:	
0*	[0 - 16]	CSIV Filename readout.

4.12.4 15-6* Option Ident.

This read-only parameter group contains information about the hardware and software configuration of the options installed in slots A, B, C0, and C1.

15-60 Option Mounted		
Array [8]		
Range:	Function:	
Size related*	[0 - 30]	View the installed option type.

15-61 Option SW Version		
Array [8]		
Range:	Function:	
Size related*	[0 - 20]	View the installed option software version.

15-62 Option Ordering No		
Range:	Function:	
Size related*	[0 - 8]	Shows the ordering number for the installed options.

15-63 Option Serial No		
Range:	Function:	
Size related*	[0 - 18]	View the installed option serial number.

15-70 Option in Slot A		
Range:	Function:	
0*	[0 - 30]	View the type code string for the option installed in slot A, and a translation of the type code string. For example, for type code string AX, the translation is No option.

15-71 Slot A Option SW Version		
Range:	Function:	
0*	[0 - 20]	View the software version for the option installed in slot A.

15-92 Defined Parameters

Range:		Function:
0*	[0 - 2000]	View a list of all defined parameters in the frequency converter. The list ends with 0.

15-97 Application Type

Range:		Function:
0*	[0 - 0xFFFFFFFF]	This parameter contains data used for the MCT 10 Set-up Software.

15-98 Drive Identification

Range:		Function:
0*	[0 - 56]	This parameter contains data used for the MCT 10 Set-up Software.

4.13 Main Menu - Data Readouts - Group 16

4.13.1 16-0* General Status

4

16-00 Control Word		
Range:	Function:	
0*	[0 - 65535]	View the control word sent from the frequency converter via the serial communication port in hex code.

Bit	Bit=0	Bit=1
00	Preset reference option lsb	–
01	Preset reference option 2 nd bit of preset references	–
02	DC brake	Ramp
03	Coasting	Enable
04	Quick stop	Ramp
05	Freeze output	Ramp
06	Ramp stop	Start
07	No function	Reset
08	No function	Jog
09	Ramp 1	Ramp 2
10	Data not valid	Valid
11	Relay_A not active	Relay_A activated
12	Relay_B not active	Relay_B activated
13	Choice of set-up lsb	–
14	No function	No function
15	No function	Reversing

Table 4.8 Control Word

16-01 Reference [Unit]		
Range:	Function:	
0 ReferenceFeed-backUnit*	[-4999 - 4999 ReferenceFeed-backUnit]	View the present reference value applied on impulse or analog basis in the unit resulting from the configuration selected in <i>parameter 1-00 Configuration Mode (Hz)</i> .

16-02 Reference [%]		
Range:	Function:	
0 %*	[-200 - 200 %]	View the total reference. The total reference is the sum of digital, analog, preset, bus, and freeze references.

16-03 Status Word		
Range:	Function:	
0*	[0 - 65535]	View the status word sent from the frequency converter via the serial communication port in hex code.

Bit	Bit=0	Bit=1
00	Control not ready	Ready
01	VLT not ready	Ready
02	Coasting	Enable
03	No fault	Trip
04	No warning	Warning
05	Reserved	–
06	No trip lock	Trip lock
07	No warning	Warning
08	Speed≠ref.	Speed=ref.
09	Local control	Bus control
10	Out of range	Frequency OK
11	Not running	Running
12	No function	No function
13	Voltage OK	Above limit
14	Current OK	Above limit
15	Temperature OK	Above limit

Table 4.9 Status Word

16-05 Main Actual Value [%]		
Range:	Function:	
0 %*	[-200 - 200 %]	View the 2-byte word sent with the status word to the bus master reporting the main actual value.

16-09 Custom Readout		
Range:	Function:	
0 CustomReadoutUnit*	[0 - 9999 CustomReadoutUnit]	View the user-defined readouts as defined in <i>parameter 0-30 Custom Readout Unit, parameter 0-31 Custom Readout Min Value, and parameter 0-32 Custom Readout Max Value</i> .

4.13.2 16-1* Motor Status

16-10 Power [kW]		
Range:	Function:	
0 kW*	[0 - 1000 kW]	Shows DC link power in kW. The value shown is calculated based on the actual motor voltage and motor current.

16-11 Power [hp]		
Range:	Function:	
0 hp*	[0 - 1000 hp]	View the the actual motor power in hp. The value shown is calculated on the basis of the actual motor voltage and motor current.

16-12 Motor Voltage		
Range:	Function:	
0 V*	[0 - 65535 V]	View the motor voltage, a calculated value used for controlling the motor.

16-13 Frequency		
Range:	Function:	
0 Hz*	[0 - 6553.5 Hz]	View the motor frequency, without resonance damping.

16-14 Motor current		
Range:	Function:	
0 A*	[0 - 655.35 A]	View the motor current measured as an average value, I _{RMS} .

16-15 Frequency [%]		
Range:	Function:	
0 %*	[0 - 6553.5 %]	View a 2-byte word reporting the actual motor frequency (without resonance damping) as a percentage (scale 0000–4000 hex) of <i>parameter 4-19 Max Output Frequency</i> .

16-16 Torque [Nm]		
Range:	Function:	
0 Nm*	[-3000 - 3000 Nm]	View the torque value with sign, applied to the motor shaft. Linearity is not exact between 160% motor current and torque in relation to the rated torque. Some motors supply more than 160% torque. Therefore, the minimum value and the maximum value depend on the maximum motor current and the motor used. The value is filtered, and thus approximately 30 ms may pass from when an input changes value to when the data readout values change. In flux control principle, this readout is compensated for in <i>parameter 1-68 Motor Inertia</i> for improved accuracy.

16-18 Motor Thermal		
Range:	Function:	
0 %*	[0 - 100 %]	View the calculated motor temperature in percentage of allowed maximum. At 100%, a trip occurs, if selected in <i>parameter 1-90 Motor Thermal Protection</i> . The basis for the calculation is the ETR function selected in <i>parameter 1-90 Motor Thermal Protection</i> .

4.13.3 16-2*

16-22 Torque [%]		
Range:	Function:	
0 %*	[-200 - 200 %]	View the torque in percent of nominal torque, with sign, applied to the motor shaft.

16-26 Power Filtered [kW]		
Range:	Function:	
0 kW*	[0 - 1000 kW]	Motor power consumption. The value shown is calculated on basis of the real-time motor voltage and motor current. The value is filtered, and a few seconds may pass between the input value change and the data readout value change.

16-27 Power Filtered [hp]		
Range:	Function:	
0 hp*	[0 - 1000 hp]	Motor power in hp. The value shown is calculated based on real-time motor voltage and motor current. The value is filtered, and a few seconds may pass between the input value change and the data readout value change.

4.13.4 16-3* Drive Status

16-30 DC Link Voltage		
Range:	Function:	
0 V*	[0 - 65535 V]	Shows the actual DC-link voltage.

16-34 Heatsink Temp.		
Range:	Function:	
0 °C*	[-128 - 127 °C]	View the heat sink temperature of the frequency converter.

16-35 Inverter Thermal		
Range:	Function:	
0 %*	[0 - 255 %]	View the percentage of thermal load on the frequency converter. At 100%, a trip occurs.

16-36 Inv. Nom. Current		
Range:	Function:	
0 A*	[0 - 655.35 A]	View the inverter nominal current. The data is used for motor overload protection, and so on.

16-37 Inv. Max. Current		
Range:	Function:	
0 A*	[0 - 655.35 A]	View the inverter maximum current. The data is used for calculation of frequency converter protection, and so on.

16-38 SL Controller State		
Range:	Function:	
0*	[0 - 20]	View the actual state of the smart logic controller (SLC).

16-39 Control Card Temp.		
Range:	Function:	
0 °C*	[0 - 65535 °C]	View the temperature on the control card, stated in °C.

4.13.5 16-5* Ref. & Feedb.

16-50 External Reference		
Range:	Function:	
0 %*	[-200 - 200 %]	View the total reference, the sum of digital, analog, preset, bus, and freeze references.

16-52 Feedback[Unit]		
Range:	Function:	
0 ProcessCtrlUnit*	[-4999 - 4999 ProcessCtrlUnit]	View the feedback resulting from the selection of scaling in <i>parameter 3-02 Minimum Reference</i> and <i>parameter 3-03 Maximum Reference</i> .

4.13.6 16-6* Inputs and Outputs

16-60 Digital Input		
Range:	Function:	
0*	[0 - 65535]	View actual state of the digital inputs 18, 19, 27 and 29.
	Bit 0	Unused
	Bit 1	Unused
	Bit 2	Digital input terminal 29
	Bit 3	Digital input terminal 27
	Bit 4	Digital input terminal 19
	Bit 5	Digital input terminal 18
	Bit 6-15	Unused
Table 4.10 Bits Definition		

16-61 Terminal 53 Setting		
Option:	Function:	
		View the setting of input terminal 53. <ul style="list-style-type: none"> Current=0 Voltage=1
[0] *	Current mode	
[1]	Voltage mode	

16-62 Analog Input AI53		
Range:	Function:	
1*	[0 - 20]	View the actual value at input 53.

16-63 Terminal 54 Setting		
View the setting of input terminal 54.		
<ul style="list-style-type: none"> Current=0 Voltage=1 		
Option:	Function:	
[0] *	Current mode	
[1]	Voltage mode	

16-64 Analog Input AI54		
Range:	Function:	
1*	[0 - 20]	View the actual value at input 54.

16-65 Analog Output AO42 [mA]		
Range:	Function:	
0 mA*	[0 - 20 mA]	View the actual value at output 42 in mA. The value shown reflects the selection in <i>parameter 6-90 Terminal 42 Mode</i> and <i>parameter 6-91 Terminal 42 Analog Output</i> .

16-66 Digital Output		
Range:	Function:	
0*	[0 - 15]	View the binary value of all digital outputs.
Definition: X: Not used 0: Low 1: High		
	XX	None used
	X0	Terminal 42 not used, terminal 45 low.
	X1	Terminal 42 not used, terminal 45 high.
	0X	Terminal 42 low, terminal 45 not used.
	0	Terminal 42 low, terminal 45 low.
	1	Terminal 42 low, terminal 45 high.
	1X	Terminal 42 high, terminal 45 not used.
	10	Terminal 42 high, terminal 45 low.
	11	Terminal 42 high, terminal 45 high.
Table 4.11 Binary Value of Digital Outputs		

16-67 Pulse Input #29 [Hz]		
Range:	Function:	
0*	[0 - 130000]	View the actual frequency rate on terminal 29.

16-71 Relay Output [bin]		
Range:	Function:	
0* [0 - 65535]	View the setting of the relay. Bits definition:	
	Bit 0~2	Unused
	Bit 3	Relay 02
	Bit 4	Relay 01
	Bit 5~15	Unused
Table 4.12 Relay Setting		

16-72 Counter A		
Range:	Function:	
0* [-32768 - 32767]	View the present value of counter A. Counters are useful as comparator operands, see <i>parameter 13-10 Comparator Operand</i> . The value can be reset or changed either via digital inputs (parameter group 5-1* <i>Digital Inputs</i>) or by using an SLC action (<i>parameter 13-52 SL Controller Action</i>).	

16-73 Counter B		
Range:	Function:	
0* [-32768 - 32767]	View the present value of counter B. Counters are useful as comparator operands (<i>parameter 13-10 Comparator Operand</i>). The value can be reset or changed either via digital inputs (parameter group 5-1* <i>Digital Inputs</i>) or by using an SLC action (<i>parameter 13-52 SL Controller Action</i>).	

16-79 Analog Output AO45		
Range:	Function:	
0 mA* [0 - 20 mA]	View the actual value at output 45 in mA. The value shown reflects the selection in <i>parameter 6-70 Terminal 45 Mode</i> and <i>parameter 6-71 Terminal 45 Analog Output</i> .	

4.13.7 16-8* Fieldbus & FC Port

Parameters for reporting the bus references and control words.

16-80 Fieldbus CTW 1		
Range:	Function:	
0* [0 - 65535]	View the 2-byte control word (CTW) received from the bus master. Interpretation of the CTW depends on the fieldbus option installed and the CTW profile selected in <i>parameter 8-10 Control Word Profile</i> . For more information, see relevant fieldbus manuals.	

16-82 Fieldbus REF 1		
Range:	Function:	
0* [-32768 - 32767]	To set the reference value, view the 2-byte word sent with the control word from the bus master. For more information, refer to the relevant fieldbus manual.	

16-84 Comm. Option STW		
Range:	Function:	
0* [0 - 65535]	View the extended fieldbus communication option status word. For more information, refer to the relevant fieldbus manual.	

16-85 FC Port CTW 1		
Range:	Function:	
1084* [0 - 65535]	View the 2-byte control word (CTW) received from the bus master. Interpretation of the control word depends on the fieldbus option installed and the control word profile selected in <i>parameter 8-10 Control Word Profile</i> .	

16-86 FC Port REF 1		
Range:	Function:	
0* [-32768 - 32767]	View the last received reference from the FC port.	

4.13.8 16-9* Diagnosis Read-Outs

16-90 Alarm Word		
Range:	Function:	
0* [0 - 0xFFFFFFFFFUL]	View the alarm word sent via the serial communication port in hex code.	

16-91 Alarm Word 2		
Range:	Function:	
0* [0 - 0xFFFFFFFFFUL]	View the alarm word 2 sent via the serial communication port in hex code.	

16-92 Warning Word		
Range:	Function:	
0* [0 - 0xFFFFFFFFFUL]	View the warning word sent via the serial communication port in hex code.	

16-93 Warning Word 2		
Range:	Function:	
0* [0 - 0xFFFFFFFFFUL]	View the warning word 2 sent via the serial communication port in hex code.	

16-94 Ext. Status Word		
Range:	Function:	
0*	[0 - 0xFFFFFFFFUL]	Shows the extended status word sent via the serial communication port in hex code.

16-95 Ext. Status Word 2		
Range:	Function:	
0*	[0 - 0xFFFFFFFFUL]	Shows the extended status word 2 sent via the serial communication port in hex code.

16-97 Alarm Word 3		
Range:	Function:	
0*	[0 - 0xFFFFFFFFUL]	View the alarm word 3 sent via the serial communication port in hex code.

4.14 Main Menu - Data Readouts 2 - Group 18

Parameters in this group are array parameters, where up to 10 fault logs can be viewed. [0] is the most recent logged data, and [9] is the oldest. Fault codes, values, and time stamp can be viewed for all logged data.

4.14.1 18-1* Fire Mode Log

18-10 FireMode Log:Event		
Range:		Function:
0*	[0 - 255]	View fire mode event.

4.14.2 18-5* Ref. & Feedb.

18-50 Sensorless Readout [unit]		
Range:		Function:
0 SensorlessUnit*	[-999999.999 - 999999.999 SensorlessUnit]	View the pressure or flow resulting from the sensorless calculations. This value is not the value used for control. The value is only updated if sensorless data supports both flow and pressure.

18-51 Memory Module Warning Reason		
Range:		Function:
0*	[0 - 0xFFFFFFFFUL]	View the reason for the memory module warning.

18-52 Memory Module ID		
Range:		Function:
0*	[0 - 0]	View the ID number of the memory module.

18-53 Memory Module Function		
Option:		Function:
		Disable or enable the memory module function.
[0]	Disabled	No data transferring between the memory module and frequency converter. The frequency converter cannot use the dongle file in the memory module.
[1] *	Enabled	The memory module function is enabled.

4.15 Main Menu - FC Closed Loop - Group 20

This parameter group is used for configuring the closed-loop PI controller, that controls the output frequency of the frequency converter.

4.15.1 20-0* Feedback

This parameter group is used to configure the feedback signal for the closed-loop PI control of the frequency converter.

20-00 Feedback 1 Source		
Option:	Function:	
		This parameter defines the inputs used as the source of the feedback signal.
[0] *	No function	
[1]	Analog Input 53	
[2]	Analog Input 54	
[3]	Pulse input 29	
[100]	Bus Feedback 1	
[104]	Sensorless Flow	
[105]	Sensorless Pressure	

20-01 Feedback 1 Conversion		
Option:	Function:	
		This parameter allows a conversion function to be applied to feedback 1.
[0] *	Linear	[0] <i>Linear</i> has no effect on the feedback.
[1]	Square root	[1] <i>Square root</i> is commonly used when a pressure sensor is used to provide flow feedback $((flow \propto \sqrt{pressure}))$.

20-12 Reference/Feedback Unit		
Option:	Function:	
[0]	None	See parameter 20-02 Feedback 1 Source Unit for details.

4.15.2 20-2* Feedback/Setpoint

This parameter group is used to determine how the PID controller uses the 3 possible feedback signals to control the output frequency of the frequency converter. This group is also used to store the 3 internal setpoint references.

20-21 Setpoint 1		
Range:	Function:	
0 ProcessCtrlUnit*	[-999999.999 - 999999.999 ProcessCtrlUnit]	Setpoint 1 is used in closed-loop mode to enter a setpoint reference that is used by the frequency converter's PID controller. See the description

20-21 Setpoint 1		
Range:	Function:	
		of parameter 20-20 Feedback Function. NOTICE The setpoint reference entered here is added to any other references that are enabled (see parameter group 3-1* References).

4.15.3 20-6* Sensorless

20-60 Sensorless Unit		
Option:	Function:	
		Select the unit to be used with parameter 18-50 Sensorless Readout [unit].
[0]	None	
[20]	l/s	

20-69 Sensorless Information		
Range:	Function:	
0*	[0 - 25]	View information about the sensorless data.

4.15.4 20-8* PI Basic Settings

Parameters for configuring the process PI control.

20-81 PI Normal/ Inverse Control		
Option:	Function:	
[0] *	Normal	Causes the frequency converter output frequency to decrease when the feedback is greater than the setpoint reference. This behavior is common for pressure-controlled supply fan and pump applications.
[1]	Inverse	Causes the frequency converter output frequency to increase when the feedback is greater than the setpoint reference. This behavior is common for temperature-controlled cooling applications, such as cooling towers.

20-83 PI Start Speed [Hz]		
Range:	Function:	
0 Hz*	[0 - 200.0 Hz]	Enter the motor speed to be attained as a start signal for commencement of PI control. After power-up, the frequency converter operates using speed open-loop control. When the process PI start speed is reached, the frequency converter changes to PI control.

20-84 On Reference Bandwidth		
Range:		Function:
5 %*	[0 - 200 %]	When the difference between the feedback and the setpoint reference is less than the value of this parameter, the frequency converter's display shows <i>Run on Reference</i> . This status can be communicated externally by programming the function of a digital output for [8] <i>Run on Reference/No Warning</i> . In addition, for serial communications, the <i>On Reference</i> status bit of the frequency converter status word is high (value=1). The <i>On Reference Bandwidth</i> is calculated as a percentage of the setpoint reference.

4.15.5 20-9* PI Controller

20-91 PI Anti Windup		
Option:		Function:
[0]	Off	Continue regulation of an error even when the output frequency cannot be increased or decreased.
[1] *	On	Cease regulation of an error when the output frequency can no longer be adjusted.

20-93 PI Proportional Gain		
Range:		Function:
0.50*	[0 - 10]	Enter the process controller proportional gain. Quick control is obtained at high amplification. However if amplification is too great, the process may become unstable.

20-94 PI Integral Time		
Range:		Function:
20 s*	[0.10 - 9999 s]	Enter the process controller integral time. Obtain quick control through a short integral time, though if the integral time is too short, the process becomes unstable. An excessively long integral time disables the integral action.

20-97 PI Feed Forward Factor		
Range:		Function:
0 %*	[0 - 400 %]	Enter the PI feed forward factor. The FF factor sends a constant fraction of the reference signal to bypass PI control. Therefore, the PI can affect only the remaining fraction of the control signal. The FF factor can increase dynamic performance.

4.16 Main Menu - Application Functions - Group 22

22-01 Power Filter Time		
Range:		Function:
0.50 s*	[0.02 - 10 s]	Set the time constant for the filtered power readout. A higher value gives a more steady readout, but a slower system response to changes.

22-02 Sleepmode CL Control Mode		
Option:	Function:	
[0] *	Normal	The feedback is detected. Some parameters are checked.
[1]	Simplified	The feedback is not detected. Only sleep speed and time are checked.

This parameter is for sleep mode running in process close loop mode. Use this parameter to configure whether to detect the feedback for sleep mode.

4

4.16.1 22-2* No-Flow Detection

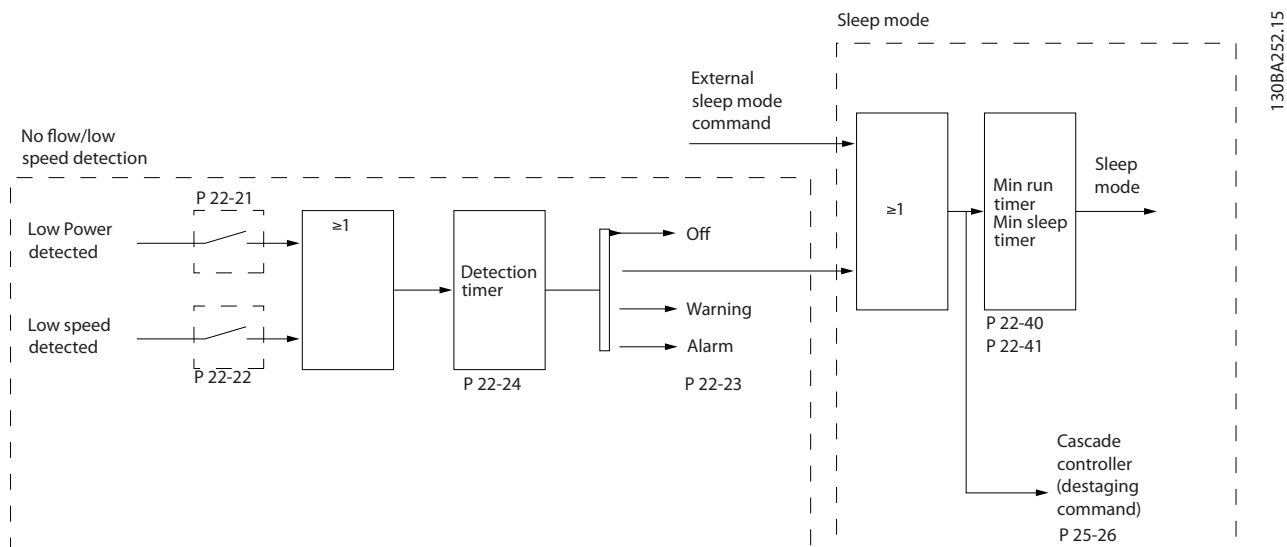

Illustration 4.19 No-flow Detection

The frequency converter includes functions for detecting if the load conditions in the system allow the motor to be stopped:

- Low power detection.
- Low speed detection.

One of these 2 signals must be active for a set time (*parameter 22-24 No-Flow Delay*) before selected action takes place. Possible actions to select (*parameter 22-23 No-Flow Function*):

- No action
- Warning
- Alarm
- Sleep mode

No-flow detection

This function is used for detecting a no-flow situation in pump systems where all valves can be closed. Can be used both when controlled by the integrated PI controller in the frequency converter or an external PI controller. Program the actual configuration in *parameter 1-00 Configuration Mode*.

Configuration mode for

- Integrated PI controller: Closed loop.
- External PI controller: Open loop.

NOTICE

Carry out no-flow tuning before setting the PI controller parameters.

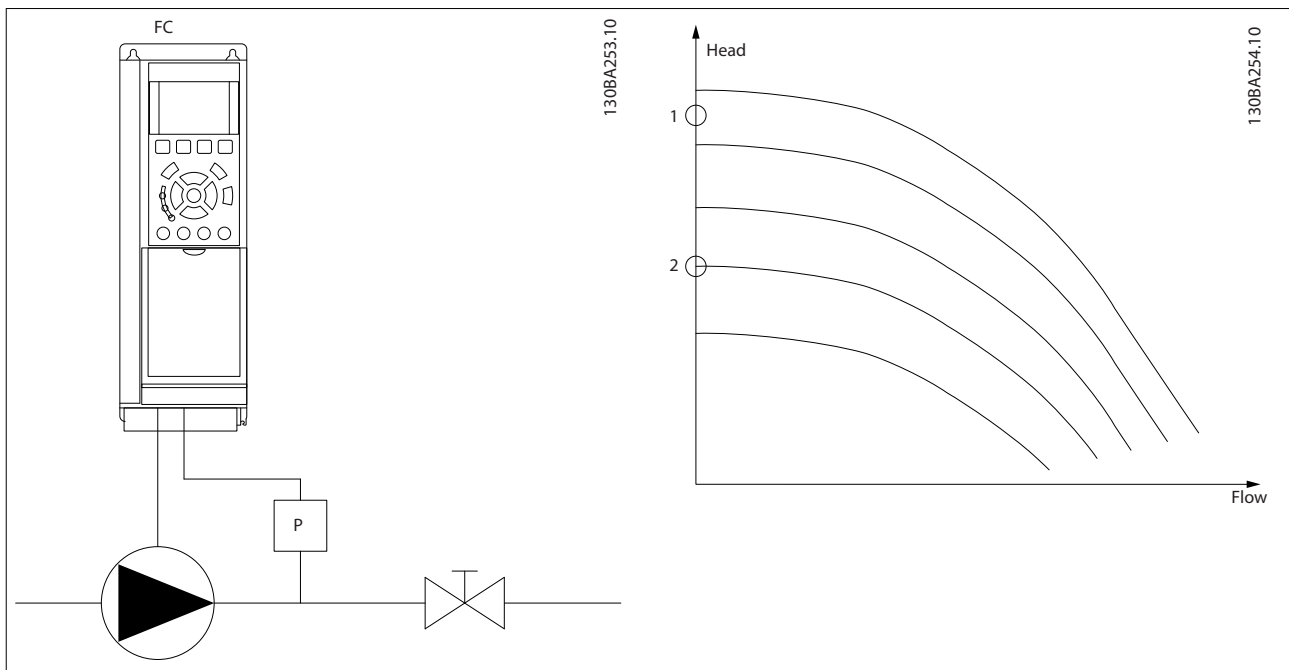

Table 4.13 No-flow Detection

No-flow detection is based on the measurement of speed and power. For a certain speed, the frequency converter calculates the power at no-flow.

This coherence is based on the adjustment of 2 sets of speed and associated power at no-flow. Monitoring power enables detection of no-flow conditions in systems with fluctuating suction pressure, or of the pump having a flat characteristic towards low speed.

The 2 sets of data must be based on measurement of power at approximately 50% and 85% of maximum speed with the valves closed. The data is programmed in parameter group 22-3* No-Flow Power Tuning. It is also possible to run a [0] Low Power Auto Set Up (*parameter 22-20 Low Power Auto Set-up*) automatically stepping through the commissioning process and storing the data measured. Set the frequency converter for [0] Open Loop in *parameter 1-00 Configuration Mode*, when carrying out the auto set-up, see *parameter group 22-3* No-Flow Power Tuning No-flow Power Tuning*.

NOTICE

If to use the integrated PI controller, carry out no-flow tuning before setting the PI controller parameters.

Low-speed detection

Low-speed detection gives a signal if the motor operates with minimum speed as set in *parameter 4-11 Motor Speed Low Limit [RPM]* or *parameter 4-12 Motor Speed Low Limit [Hz]*. Actions are common with no-flow detection (individual selection not possible).

The use of low-speed detection is not limited to systems with a no-flow situation. Low-speed detection can be used in any system where operation at minimum speed allows a stop of the motor until the load calls for a speed higher than minimum speed. This could, for example, be in systems with fans and compressors.

NOTICE

In pump systems, ensure that the minimum speed in *parameter 4-11 Motor Speed Low Limit [RPM]* or *parameter 4-12 Motor Speed Low Limit [Hz]* is set high enough for detection as the pump can run with a rather high speed even with valves closed.

Dry-pump detection

If the pump has run dry (low power consumption-high speed), no-flow detection can also be used for detecting. Can be used with both the integrated PI controller and an external PI controller.

The condition for dry-pump signal:

- Power consumption below no-flow level.

and

- Pump running at maximum speed or maximum reference open loop, whichever is lowest.

The signal must be active for a set time (*parameter 22-27 Dry Pump Delay*) before the selected action takes place.

Possible actions to select (*parameter 22-26 Dry Pump Function*):

- Warning
- Alarm

Enable and commission no-flow detection in *parameter 22-23 No-Flow Function* and parameter group 22-3* *No-Flow Power Tuning*.

4

22-26 Dry Pump Function		
Select the action for dry-pump operation.		
Option:	Function:	
[0]	Off	<p>NOTICE</p> <p>To use dry-pump detection:</p> <ol style="list-style-type: none"> 1. Enable low-power detection in <i>parameter 22-21 Low Power Detection</i>. 2. Commission low-power detection using parameter group 22-3* <i>No-flow Power Tuning No-flow Power Tuning</i>. <p>NOTICE</p> <p>Do not set <i>parameter 14-20 Reset Mode</i> to [13] <i>Infinite auto reset</i>, when <i>parameter 22-26 Dry Pump Function</i> is set to [2] <i>Alarm</i>. Doing so causes the frequency converter to continuously cycle between running and stopping when a dry-pump condition is detected.</p>

22-26 Dry Pump Function		
Select the action for dry-pump operation.		
Option:	Function:	
		<p>NOTICE</p> <p>For frequency converters with constant-speed bypass. If an automatic bypass function starts the bypass at persistent alarm conditions, disable the automatic bypass function, if [2] <i>Alarm</i> or [3] <i>Man. Reset Alarm</i> is selected as the dry-pump function.</p> <p>The frequency converter continues to run, but activates a dry-pump warning (<i>Warning 93, Dry pump</i>). A frequency converter digital output or a serial communication bus can communicate a warning to other equipment.</p>
[1]	Warning	
[2]	Alarm	The frequency converter stops running and activates a dry-pump alarm (<i>Alarm 93, Dry pump</i>). A frequency converter digital output or a serial communication bus can communicate an alarm to other equipment.
[3]	Man. Reset Alarm	The frequency converter stops running and activates a dry-pump alarm (<i>Alarm 93, Dry pump</i>). A frequency converter digital output or a serial communication bus can communicate an alarm to other equipment.

22-27 Dry Pump Delay		
Range:	Function:	
10 s* [0 - 600 s]	Defines for how long the dry-pump condition must be active before activating a warning or an alarm. The frequency converter waits for the no-flow delay time (<i>parameter 22-24 No-Flow Delay</i>) to expire before the timer for the dry-pump delay starts.	

4.16.2 22-3* No-flow Power Tuning

If auto set-up is disabled in *parameter 22-20 Low Power Auto Set-up*, the tuning sequence is:

1. Close the main valve to stop flow.
2. Run with motor until the system has reached normal operating temperature.
3. Press [Hand On] and adjust speed for approximately 85% of rated speed. Note the exact speed.
4. Read power consumption either by looking for actual power in the data line in the LCP or by viewing 1 of the following parameters:
 - 4a *Parameter 16-10 Power [kW]*.
or
 - 4b *Parameter 16-11 Power [hp]* in the Main Menu.

Note the power readout.

5. Change speed to approximately 50% of rated speed. Note the exact speed.
6. Read power consumption either by looking for actual power in the data line in the LCP or by viewing 1 of the following parameters:
 - 6a *Parameter 16-10 Power [kW]*.
or
 - 6b *Parameter 16-11 Power [hp]* in the Main Menu.

Note the power readout.

7. Program the speeds used in:
 - 7a *Parameter 22-32 Low Speed [RPM]*.
 - 7b *Parameter 22-33 Low Speed [Hz]*.
 - 7c *Parameter 22-36 High Speed [RPM]*.
 - 7d *Parameter 22-37 High Speed [Hz]*.
8. Program the associated power values in:
 - 8a *Parameter 22-34 Low Speed Power [kW]*.
 - 8b *Parameter 22-35 Low Speed Power [HP]*.
 - 8c *Parameter 22-38 High Speed Power [kW]*.

8d *Parameter 22-39 High Speed Power [HP]*.

9. Switch back with [Auto On] or [Off].

NOTICE

Set *parameter 1-03 Torque Characteristics* before tuning takes place.

22-38 High Speed Power [kW]		
Range:	Function:	
Size related* [0 - 5.50 kW]	To be used, if <i>parameter 0-03 Regional Settings</i> is set for [0] <i>International</i> (parameter not visible if [1] <i>North America</i> is selected). Set power consumption at 85% speed level. This function is used for storing values necessary to tune no-flow detection.	

4.16.3 22-4* Sleep Mode

The purpose of sleep mode is to allow the frequency converter to stop itself in situations where the system is in balance. This function saves energy, and keeps the system from being over-satisfied (excessive pressure, water excessively cooled in cooling towers, building pressurization problems). This is also important as some applications prevent the frequency converter from adjusting motor down to low speed. This might damage pumps, cause insufficient lubrication in gearboxes, and make fans unstable.

The sleep controller has 2 important functions: The ability to go to sleep at right time; and the ability to come out of a sleep mode at right time. The goal is to keep the frequency converter in sleep mode as long as possible to avoid cycling the motor on and off frequently, and, at the same, time keep the controlled system variable within the acceptable range.

The sequence when running sleep mode in open loop:

1. The motor speed is less than the speed set in *parameter 22-47 Sleep Speed [Hz]*. The motor runs longer than the time duration set in *parameter 22-40 Minimum Run Time*. The sleep condition lasts longer than the time set in *parameter 22-48 Sleep Delay Time*.
2. The frequency converter ramps the motor speed down to *parameter 1-82 Min Speed for Function at Stop [Hz]*.
3. The frequency converter activates *parameter 1-80 Function at Stop*. The frequency converter is now in sleep mode.
4. The frequency converter compares the speed setpoint with *parameter 22-43 Wake-Up Speed [Hz]* to detect a wake-up situation.

5. The speed setpoint is greater than *parameter 22-43 Wake-Up Speed [Hz]*. The sleep condition has lasted longer than the time set in *parameter 22-41 Minimum Sleep Time*. The wake-up condition lasts longer than the time set in *parameter 22-49 Wake-Up Delay Time*. The frequency converter is now out of sleep mode.
6. Go back to speed open-loop control (ramp motor speed up to the speed setpoint).

The sequence when running sleep mode in closed loop:

1. The frequency converter goes into boost status if the following conditions are met.
 - If *parameter 22-02 Sleepmode CL Control Mode* is set to [0] *Normal*:
 - The motor speed is less than the value in *parameter 22-47 Sleep Speed [Hz]*.
 - The feedback is above the reference.
 - The motor runs longer than the time in *parameter 22-40 Minimum Run Time*.
 - The sleep condition lasts longer than the time in *parameter 22-48 Sleep Delay Time*.
 - If *parameter 22-02 Sleepmode CL Control Mode* is set to [1] *Simplified*:
 - The motor speed is less than the value in *parameter 22-47 Sleep Speed [Hz]*.
 - The motor runs longer than the time in *parameter 22-40 Minimum Run Time*.
 - The sleep condition lasts longer than the time in *parameter 22-48 Sleep Delay Time*.

If *parameter 22-45 Setpoint Boost* is not set, the frequency converter goes into sleep mode.
2. After the time in *parameter 22-46 Maximum Boost Time* has passed, the frequency converter ramps down the motor speed to the speed in *parameter 1-82 Min Speed for Function at Stop [Hz]*.
3. The frequency converter activates *parameter 1-80 Function at Stop*. The frequency converter is now in sleep mode.

4. The frequency converter is out of sleep mode:
 - 4a When the error between the reference and the feedback is greater than *parameter 22-44 Wake-Up Ref./FB Diff*, and
 - 4b the sleep time is longer than the time in *parameter 22-41 Minimum Sleep Time*, and
 - 4c the wake-up condition lasts longer than the time set in *parameter 22-48 Sleep Delay Time*.
5. The frequency converter goes back to closed-loop control.

NOTICE

Sleep mode is not active when local reference is active (set speed manually using the navigation keys on the LCP).

Sleep mode does not work in local mode. Perform an auto set-up in open loop before setting input/output in closed loop.

22-40 Minimum Run Time		
Range:	Function:	
10 s*	[0 - 600 s]	Set the wanted minimum running time for the motor after a start command (digital input or bus) before entering sleep mode.

22-41 Minimum Sleep Time		
Range:	Function:	
10 s*	[0 - 600 s]	Set the minimum time for staying in sleep mode. This time overrides any wake-up conditions.

22-43 Wake-Up Speed [Hz]		
Range:	Function:	
10*	[0 - 400.0]	Only to be used if <i>parameter 1-00 Configuration Mode</i> , is set for open loop and an external controller applies speed reference. Set the reference speed at which the sleep mode should be deactivated.

22-44 Wake-Up Ref./FB Diff		
Range:	Function:	
10 %*	[0 - 100 %]	Only to be used if <i>parameter 1-00 Configuration Mode</i> is set for closed loop and the integrated PI controller is used for controlling the pressure. Set the pressure drop allowed in percentage of setpoint for the pressure (P _{set}) before canceling the sleep mode.

22-45 Setpoint Boost		
Range:		Function:
0 % *	[-100 - 100 %]	Only to be used if <i>parameter 1-00 Configuration Mode</i> is set for closed loop and the integrated PI controller is used. In systems with for example constant pressure control, it is advantageous to increase the system pressure before the motor is stopped. This increase extends the time the motor is stopped and helps to avoid frequent start/stop. Set the required overpressure/overtemperature in percentage of setpoint for the pressure (P_{set})/ temperature before entering the sleep mode. If setting for 5%, the boost pressure is $P_{set} \times 1.05$. The negative values can be used for cooling tower control where a negative change is needed.

22-46 Maximum Boost Time		
Range:		Function:
60 s*	[0 - 600 s]	Only to be used if <i>parameter 1-00 Configuration Mode</i> is set for [3] <i>Closed loop</i> and the integrated PI controller is used for controlling the pressure. Set the maximum time for which boost mode is allowed. If the set time is exceeded, the frequency converter enters the sleep mode without waiting for the set boost pressure to be reached.

22-47 Sleep Speed [Hz]		
Range:		Function:
0*	[0 - 400.0]	Set the speed below which the frequency converter goes into sleep mode.

22-48 Sleep Delay Time		
Range:		Function:
0 s	[0 - 3600 s]	Set the delay time that the motor waits before entering sleep mode when the condition to entering sleep mode is met.

22-49 Wake-Up Delay Time		
Range:		Function:
0 s	[0 - 3600 s]	Set the delay time that the motor waits before waking up from sleep mode when the condition for wake-up is met.

4.16.4 22-5* End of Curve

The end-of-curve conditions occur when a pump is yielding a too large volume to ensure the set pressure. This situation can occur if there is a leakage in the distribution pipe system after the pump causing the pump to operate at the end of the pump characteristic, valid for the maximum speed set in *parameter 4-13 Motor Speed High Limit [RPM]* or *parameter 4-14 Motor Speed High Limit [Hz]*. If the feedback is 2.5% of the programmed value in *parameter 20-14 Maximum Reference/Feedb.* (or numerical value of *parameter 20-13 Minimum Reference/Feedb.*

whichever is highest) below the setpoint for the required pressure for a set time (*parameter 22-51 End of Curve Delay*), and the pump runs with maximum speed set in *parameter 4-13 Motor Speed High Limit [RPM]* or *parameter 4-14 Motor Speed High Limit [Hz]*, the function selected in *parameter 22-50 End of Curve Function* takes place.

It is possible to get a signal on 1 of the digital outputs by selecting [192] *End of Curve* in parameter group 5-3* *Digital Outputs* and/or parameter group 5-4* *Relays*. The signal is present, when an end-of-curve condition occurs and the selection in *parameter 22-50 End of Curve Function* is different from [0] *Off*. The end-of-curve function can only be used when operating with the built-in PID controller ([3] *Closed loop* in *parameter 1-00 Configuration Mode*).

22-50 End of Curve Function		
Option:	Function:	
		<p>NOTICE</p> <p>Automatic restart resets the alarm and restarts the system.</p> <p>NOTICE</p> <p>Do not set <i>parameter 14-20 Reset Mode</i>, to [13] <i>Infinite auto reset</i>, when <i>parameter 22-50 End of Curve Function</i> is set to [2] <i>Alarm</i>. Doing so causes the frequency converter to continuously cycle between running and stopping when an end-of-curve condition is detected.</p> <p>NOTICE</p> <p>If the frequency converter is equipped with a constant speed bypass with an automatic bypass function that starts the bypass if the frequency converter experiences a persistent alarm condition, disable the automatic bypass function if [2] <i>Alarm</i> or [3] <i>Man. Reset Alarm</i> is selected as the end-of-curve function.</p>
[0] *	Off	End-of-curve monitoring is not active.
[1]	Warning	The frequency converter continues to run, but activates an end-of-curve warning (<i>Warning 94, End of curve</i>). A frequency converter digital output or a serial communication bus can communicate a warning to other equipment.
[2]	Alarm	The frequency converter stops running and activates an end-of-curve alarm (<i>Alarm 94, End of curve</i>). A frequency converter digital output or a serial communication bus can communicate an alarm to other equipment.

22-50 End of Curve Function		
Option:	Function:	
[3] Man. Reset Alarm	The frequency converter stops running and activates an end-of-curve alarm (<i>Alarm 94, End of curve</i>). A frequency converter digital output or a fieldbus can communicate an alarm to other equipment.	

22-51 End of Curve Delay		
Range:	Function:	
10 s* [0 - 600 s]	When an end-of-curve condition is detected, a timer is activated. When the time set in this parameter expires, and the end-of-curve condition is steady during the entire period, the function set in <i>parameter 22-50 End of Curve Function</i> is activated. If the condition disappears before the timer expires, the timer is reset.	

4.16.5 22-6* Broken Belt Detection

Use broken-belt detection in both closed-loop and open-loop systems for pumps and fans. If the estimated motor torque (current) is below the broken-belt torque (current) value (*parameter 22-61 Broken Belt Torque*), and the frequency converter output frequency is above or equal to 15 Hz, *parameter 22-60 Broken Belt Function* is performed.

22-60 Broken Belt Function		
Selects the action to be performed if the broken-belt condition is detected.		
Option:	Function:	
[0] * Off		
[1] Warning	The frequency converter continues to run, but activates a broken-belt warning <i>Warning 95, Broken Belt</i> . A frequency converter digital output or a serial communication bus can communicate a warning to other equipment.	
[2] Trip	The frequency converter stops running and activates a broken-belt alarm <i>Alarm 95, Broken Belt</i> . A frequency converter digital output or a serial communication bus can communicate an alarm to other equipment.	

⚠ WARNING

Do not set *parameter 14-20 Reset Mode*, to [13] *Infinite auto reset*, when *parameter 22-60 Broken Belt Function* is set to [2] *Trip*. Doing so causes the frequency converter to continuously cycle between running and stopping when a broken-belt condition is detected.

NOTICE

If the automatic bypass function is enabled, the bypass starts when the frequency converter experiences a persistent alarm condition. In this case, disable the automatic bypass function if [2] *Trip* is selected as the broken-belt function.

22-61 Broken Belt Torque		
Range:	Function:	
10 %* [5 - 100 %]	Sets the broken-belt torque as a percentage of the rated motor torque.	

22-62 Broken Belt Delay		
Range:	Function:	
10 s* [0 - 600 s]	Sets the time for which the broken-belt conditions must be active before carrying out the action selected in <i>parameter 22-60 Broken Belt Function</i> .	

4.16.6 22-8* Flow Compensation

In certain applications, it is not possible for a pressure transducer to be placed at a remote point in the system, and it can only be located close to the fan/pump outlet. Flow compensation operates by adjusting the setpoint according to the output frequency, which is almost proportional to flow. Thus, it compensates for higher losses at higher flow rates.

H_{DESIGN} (required pressure) is the setpoint for closed-loop (PI) operation of the frequency converter and is set as for closed-loop operation without flow compensation.

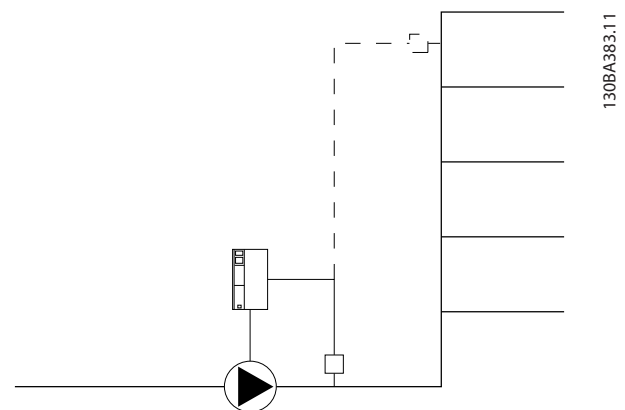

Illustration 4.20 Flow Compensation Set-up

There are 2 methods which can be employed, depending on whether the speed at system design working point is known.

Parameter used	Speed at design point KNOWN	Speed at design point UNKNOWN
Parameter 22-80 Flow Compensation	+	+
Parameter 22-81 Square-linear Curve Approximation	+	+
Parameter 22-82 Work Point Calculation	+	+
Parameter 22-83 Speed at No-Flow [RPM]/parameter 22-84 Speed at No-Flow [Hz]	+	+
Parameter 22-85 Speed at Design Point [RPM]/parameter 22-86 Speed at Design Point [Hz]	+	-
Parameter 22-87 Pressure at No-Flow Speed	+	+
Parameter 22-88 Pressure at Rated Speed	-	+
Parameter 22-89 Flow at Design Point	-	+
Parameter 22-90 Flow at Rated Speed	-	+

Table 4.14 Speed at Design Point Known/Unknown

22-80 Flow Compensation		
Option:	Function:	
[0] *	Disabled	Setpoint compensation not active.
[1]	Enabled	Setpoint compensation is active. Enabling this parameter allows the flow-compensated setpoint operation.

22-81 Square-linear Curve Approximation		
Range:	Function:	
100 %*	[0 - 100 %]	NOTICE Not visible when running in cascade.
		Example 1 Adjustment of this parameter allows the shape of the control curve to be adjusted. 0=Linear 100%=Ideal shape (theoretical).

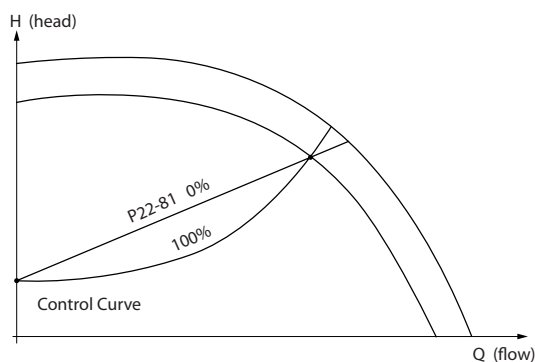

Illustration 4.21 Square-Linear Curve Approximation

22-82 Work Point Calculation	
Option:	Function:

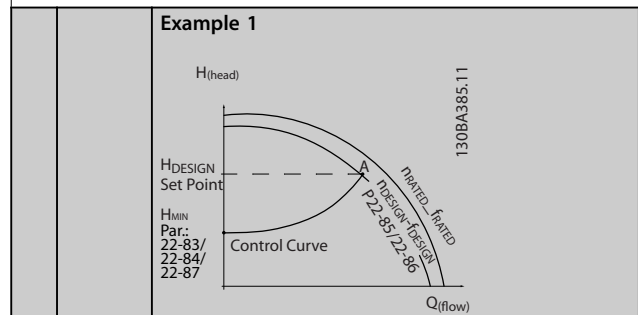

Illustration 4.22 Speed at System Design Working Point is Known

From the datasheet showing characteristics for the specific equipment at different speeds, simply reading across from the H_{DESIGN} point and the Q_{DESIGN} point allows finding point A, which is the system design working point. The pump characteristics at this point should be identified and the associated speed programmed. Closing the valves and adjusting the speed until H_{MIN} has been achieved allows the speed at the no-flow point to be identified.

Adjustment of *parameter 22-81 Square-linear Curve Approximation* then allows the shape of the control curve to be adjusted infinitely.

Example 2

Speed at system design working point is not known: Where the speed at system design working point is unknown, another reference point on the control curve needs to be determined based on the datasheet. By looking at the curve for the rated speed and plotting the design pressure (H_{DESIGN} , Point C), the flow at that pressure, Q_{RATED} , can be determined. Similarly, by plotting the design flow (Q_{DESIGN} , Point D), the

22-82 Work Point Calculation		
Option:	Function:	
		<p>pressure H_{DESIGN} at that flow can be determined. Knowing these 2 points on the pump curve, along with H_{MIN} as described above, allows the frequency converter to calculate the reference point B and thus to plot the control curve, which also includes the system design working point A.</p> <p>Illustration 4.23 Speed at System Design Working Point is not Known</p>
[0]	Disabled	Work point calculation not active. To be used if speed at design point is known.
[1]	Enabled	<p>Work point calculation is active. Enabling this parameter allows the calculation of the unknown system design working point at 50/60 Hz speed, from the input data set in:</p> <ul style="list-style-type: none"> Parameter 22-83 Speed at No-Flow [RPM]. Parameter 22-84 Speed at No-Flow [Hz]. Parameter 22-87 Pressure at No-Flow Speed. Parameter 22-88 Pressure at Rated Speed. Parameter 22-89 Flow at Design Point. Parameter 22-90 Flow at Rated Speed.

22-84 Speed at No-Flow [Hz]		
Range:	Function:	
0 Hz*	[0 - 400.0 Hz]	<p>Resolution 0.033 Hz.</p> <p>Enter the motor speed in Hz at which flow has effectively stopped and minimum pressure H_{MIN} is achieved. Alternatively, enter the speed in RPM in parameter 22-83 Speed at No-Flow [RPM]. If it has been decided to use Hz in parameter 0-02 Motor Speed Unit, parameter 22-86 Speed at Design Point [Hz] should also be used. Closing the valves and reducing the speed until minimum pressure H_{MIN} is achieved determines this value.</p>

22-86 Speed at Design Point [Hz]		
Range:	Function:	
Size related*	[0.0 - 400.0 Hz]	<p>Resolution 0.033 Hz.</p> <p>Only visible when parameter 22-82 Work Point Calculation is set to [0] Disabled. Enter the motor speed in Hz at which the system design working point is achieved. Alternatively, enter the speed in RPM in parameter 22-85 Speed at Design Point [RPM]. If it has been decided to use Hz in parameter 0-02 Motor Speed Unit, parameter 22-83 Speed at No-Flow [RPM] should also be used.</p>

22-87 Pressure at No-Flow Speed		
Range:	Function:	
0*	[0 - 999999.999]	Enter the pressure H_{MIN} corresponding to speed at no-flow in reference/feedback units.

22-88 Pressure at Rated Speed		
Range:	Function:	
999999.999*	[0 - 999999.999]	Enter the value corresponding to the pressure at rated speed, in reference/feedback units. This value can be defined using the pump datasheet.

See parameter 22-88 Pressure at Rated Speed point A.

22-89 Flow at Design Point		
Range:	Function:	
0*	[0 - 999999.999]	Flow at design point (no units).

22-90 Flow at Rated Speed		
Also see parameter 22-82 Work Point Calculation.		
Range:	Function:	
0*	[0 - 999999.999]	Enter the value corresponding to flow at rated speed. This value can be defined using the pump datasheet.

4.17 Main Menu - Application Functions 2 - Group 24

4.17.1 24-0* Fire Mode

⚠ WARNING

EQUIPMENT DAMAGE AND PERSONAL INJURY

Non-interruption of the frequency converter due to fire mode operation could cause overpressure and damage the system and its components, hereunder dampers, and air ducts. The frequency converter itself could be damaged and it may cause damage or fire.

- Ensure that the system is properly designed and components used are carefully selected.
- Ensure that the ventilation systems working in life safety applications are approved by the local fire authorities.

Background

Fire mode is for use in critical situations, where it is imperative for the motor to keep running, regardless of the frequency converter's normal protective functions. These could be ventilation fans in tunnels or stairwells for instance, where continued operation of the fan facilitates safe evacuation of personnel if there is a fire. Some selections of fire mode function cause alarms and trip conditions to be ignored, enabling the motor to run without interruption.

Activation

Fire mode is activated only via digital input terminals. See parameter group 5-1* *Digital Inputs*.

Messages in display

When fire mode is activated, the display shows the status message *Fire Mode*.

Once the fire mode is deactivated, the status message disappears.

If an alarm with warranty implications (see parameter 24-09 *FM Alarm Handling*) occurs while the frequency converter is active in fire mode, the display shows the status message *Fire Mode Limits Exceeded*. Once this status message appears, it remains permanently and cannot be removed.

Digital and relay outputs can be configured for the status messages *Fire Mode Active*. See parameter group 5-3* *Digital Outputs* and parameter group 5-4* *Relays*.

Access the status messages *Fire Mode* and *Fire Mode Limits Exceeded* via the extended status word.

Message	Type	LCP	Message	Warning Word 2	Extended status Word 2
Fire Mode	Status	+	+		+ (bit 25)
Fire Mode Limits Exceeded	Status	+	+		+ (bit 27)

Table 4.15 Fire Mode Display Messages

Log

The fire mode log shows an overview of events related to fire mode in the fire mode log, see also parameter group 18-1* *Fire Mode Log*.

The log includes up to 10 of the latest events. *Fire Mode Limits Exceeded* has a higher priority than *Fire Mode Active*. The log cannot be reset.

The following events are logged:

- Fire mode activated.
- Fire mode limits exceeded (warranty affecting alarms).

All other alarms occurring while fire mode is active are logged as usual.

NOTICE

During fire mode operation, all stop commands to the frequency converter are ignored, including coast, coast inverse, and external interlock.

NOTICE

If setting the command [11] *Start Reversing* on a digital input terminal in parameter 5-10 *Terminal 18 Digital Input*, the frequency converter understands this command as a reversing command.

24-00 FM Function		
Option:	Function:	
		NOTICE In fire mode, alarms are produced or ignored in accordance with the selection in parameter 24-09 <i>FM Alarm Handling</i> .
[0] *	Disabled	Fire mode function is not active.
[1]	Enabled-Run Forward	In this mode, the motor continues to operate in a clockwise direction.
[2]	Enabled-Run Reverse	In this mode, the motor continues to operate in a counterclockwise direction.
[3]	Enabled-Coast	While this mode is selected, the output is disabled, and the motor is allowed to coast to stop. When parameter 24-01 <i>Fire Mode Configuration</i> is set to [3] <i>Closed Loop</i> , this mode cannot be selected.

24-00 FM Function		
Option:	Function:	
[4] Enabled-Run Fwd/Rev	In this mode, the motor operates in a clockwise direction. When receiving a reversing signal, the motor operates in counterclockwise direction. If <i>parameter 24-01 Fire Mode Configuration</i> is set to [3] <i>Closed Loop</i> , the motor cannot operate in counterclockwise direction.	

24-05 FM Preset Reference		
Range:	Function:	
0 %* [-100 - 100 %]	Enter the required preset reference/set point as a percentage of the fire mode maximum reference set in Hz.	

24-09 FM Alarm Handling		
Option:	Function:	
	<p>NOTICE Warranty-affecting alarms. Certain alarms can affect the lifetime of the frequency converter. If 1 of these ignored alarms occurs while in fire mode, a log of the event is stored in the fire mode log. The fire mode log stores the 10 latest events of warranty-affecting alarms, fire mode activation, and fire mode deactivation.</p> <p>NOTICE The setting in <i>parameter 14-20 Reset Mode</i> is disregarded when fire mode is active (see <i>parameter group 24-0*</i>, <i>Fire Mode</i>).</p>	
[0] Trip+Reset, Critical Alarms	If this mode is selected, the frequency converter continues to run, ignoring most alarms, even if doing so may result in damage to the frequency converter. Critical alarms are alarms, which cannot be suppressed but a restart attempt is possible (Infinity Automatic Reset).	
[1] Trip, * Crit.Alarms	If there is a critical alarm, the frequency converter trips and does not autorestart (manual reset).	
[2] Trip, All Alarms/Test	It is possible to test the operation of fire mode, but all alarm states are activated normally (manual reset).	

Num-ber	Description	Critical alarms	Warranty affecting alarms
4	Mains ph. loss		x
7	DC over volt	x	x
9	Inverter overloaded		x
13	Over current	x	x
14	Earth fault	x	x
16	Short circuit	x	x
38	Internal fault	x	
69	Power card temp		x

Table 4.16 Fire Mode Alarms

4.17.2 24-1* Drive Bypass

If a fire mode coast occurs (see *parameter 24-00 FM Function*), the frequency converter includes a feature that can automatically activate an external electro-mechanical bypass.

The bypass switches the motor to operation directly on line. One of the digital outputs or relays in the frequency converter activates the external bypass, when programmed in *parameter group 5-3* Digital Outputs* or *parameter group 5-4* Relays*.

NOTICE

The drive bypass cannot be deactivated if in fire mode. It is deactivated only by either removing the fire mode command signal or the supply to the frequency converter.

When the drive bypass function is activated, the display on the LCP shows the status message *Drive Bypass*. This message has a higher priority than the fire mode status messages. When the automatic drive bypass function is enabled, it cuts in the external bypass according to *Illustration 4.24*.

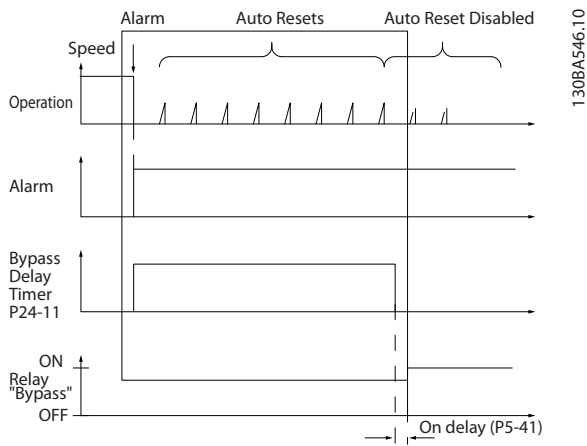

Illustration 4.24 Drive Bypass Function

Read the status in the extended status word 2, bit number 24.

24-10 Drive Bypass Function		
Option:	Function:	
		This parameter determines which circumstances activate the bypass function:
[0] *	Disabled	
[2]	Enabled (Fire Mode only)	If the timer expires before reset attempts have completed, the bypass function operates at trip at critical alarms, coast, or bypass delay timer.

24-11 Drive Bypass Delay Time		
Range:	Function:	
0 s* [0 - 600 s]	<p>Programmable in 1 s increments. Once the bypass function is activated in accordance with the setting in <i>parameter 24-10 Drive Bypass Function</i>, the bypass delay timer begins to operate. If the frequency converter has been set for several restart attempts, the timer continues to run while the frequency converter tries to restart. If the motor has restarted within the time period of the bypass delay timer, the timer is reset.</p> <p>If the motor fails to restart at the end of the bypass delay time, the frequency converter bypass relay, which has been programmed for bypass in <i>parameter 5-40 Function Relay</i>, is activated.</p> <p>Where no restart attempts are programmed, the timer runs for the delay period set in this parameter and then activates the frequency converter bypass relay, which has been programmed for bypass in <i>parameter 5-40 Function Relay</i>.</p>	

4.18 Main Menu - Special Features - Group

30

4.18.1 30-2* Adv. Start Adjust

30-20 High Starting Torque Time [s]		
Range:		Function:
Size related*	[0 - 60 s]	High starting torque time for PM motors in VVC ⁺ mode without feedback.

30-21 High Starting Torque Current [%]		
Range:		Function:
Size related*	[0 - 200.0 %]	High starting torque current for PM motor in VVC ⁺ mode without feedback.

30-22 Locked Rotor Detection		
Locked Rotor Detection for PM motor.		
Option:		Function:
[0]	Off	
[1] *	On	

30-23 Locked Rotor Detection Time [s]		
Range:		Function:
1 s*	[0.05 - 1 s]	Locked Rotor Detection Time for PM motor.

5 Diagnostics and Troubleshooting

5.1 Alarms and Warnings Overview

The LEDs on the front of the frequency converter signal a warning or an alarm, which is then indicated by a code on the display.

Event type	LED signal
Warning	Yellow
Alarm	Flashing red

Table 5.1 Event Type LED Signals

A warning remains active until its cause is no longer present. Under certain circumstances, motor operation can continue. Warning messages can be critical, but are not necessarily so.

If an alarm occurs, the frequency converter trips. Reset of alarms is required to restart operation, once the cause is rectified.

To reset an alarm:

- Press [Reset].
- Use the reset function via a digital input.
- Reset via serial communication.
- Use the auto reset function, which is a default setting. See *parameter 14-20 Reset Mode*. This form of reset cannot be used for a trip lock alarm.

NOTICE

To restart the motor after reset pressing [Reset], press [Auto On] or [Hand On].

When an alarm fails to reset, check:

- That the cause is rectified.
- For trip lock, refer to *Table 5.2*.

Trip

A trip is the action occurring when an alarm has appeared. The event that caused an alarm cannot damage the frequency converter or cause dangerous conditions. The trip coasts the motor and can be reset by pressing [Reset] or via a digital input (parameter group 5-1* *Digital Inputs [1] Reset*). For alarms with trip, but no trip lock, reset using the automatic reset function in *parameter 14-20 Reset Mode*.

Trip lock

A trip lock alarm occurs in situations, which can result in equipment damage. A trip lock alarm offers more protection, because the mains supply must be switched off before the alarm can be reset. After rectification of the cause and after power cycling, the frequency converter is no longer blocked. Reset as described in the previous.

CAUTION

UNINTENDED START

Automatic wake-up can occur when using reset via *parameter 14-20 Reset Mode*. Failure to be prepared for start can result in personal injury.

- Be prepared for unexpected start.

Warning and alarm

For events marked with warning and alarm in *Table 5.2*:

- A warning occurs before an alarm.
- The event can be set to signal either warning or alarm.

Example: *Parameter 1-90 Motor Thermal Protection*.

If this parameter is set to warning options after an alarm, the motor coasts, and both the alarm and warning LEDs flash. Once the cause is rectified, only the alarm LED continues flashing. If this parameter is set to trip options after an alarm or trip, the motor coasts and the warning LED stops flashing when the alarm LED starts flashing.

Alarm/warning number	Fault text	Warning	Alarm	Trip lock	Cause of problem
2	Live zero error	X	X	-	Signal on terminal 53 or 54 is less than 50% of value set in: <ul style="list-style-type: none"> • <i>Parameter 6-10 Terminal 53 Low Voltage</i>. • <i>Parameter 6-12 Terminal 53 Low Current</i>. • <i>Parameter 6-20 Terminal 54 Low Voltage</i>. • <i>Parameter 6-22 Terminal 54 Low Current</i>. See also parameter group 6-0* <i>Analog In/Out</i> .
3	No motor	X	-	-	A motor has not been connected to the frequency converter.
4	Mains ph. loss	X	X	X	Missing phase on supply side or excess voltage imbalance. Check supply voltage. See <i>parameter 14-12 Function at Mains Imbalance</i> .

Alarm/ warning number	Fault text	Warning	Alarm	Trip lock	Cause of problem
7	DC over volt	X	X	–	DC-link voltage exceeds limit.
8	DC under volt	X	X	–	DC-link voltage is lower than voltage warning low-limit.
9	Inverter overload	X	X	–	More than 100% load for too long.
10	Motor ETR over	X	X	–	Motor is overheated due to more than 100% load for too long. See <i>parameter 1-90 Motor Thermal Protection</i> .
11	Motor th over	X	X	–	Thermistor or thermistor connection is disconnected. See <i>parameter 1-90 Motor Thermal Protection</i> .
13	Over Current	X	X	X	Inverter peak current limit is exceeded.
14	Earth Fault	X	X	X	Discharge from output phases to ground.
16	Short Circuit	–	X	X	Short circuit in motor or on motor terminals.
17	Control word timeout	X	X	–	No communication to frequency converter. See parameter group 8-0* <i>Comm. and Options</i> .
24	Fan fault	–	–	–	External fans have failed either due to defect hardware, or due to missing fans.
30	U phase loss	–	X	X	Motor phase U is missing. Check the phase. See <i>parameter 4-58 Missing Motor Phase Function</i> .
31	V phase loss	–	X	X	Motor phase V is missing. Check the phase. See <i>parameter 4-58 Missing Motor Phase Function</i> .
32	W phase loss	–	X	X	Motor phase W is missing. Check the phase. See <i>parameter 4-58 Missing Motor Phase Function</i> .
34	Fieldbus fault	X	–	–	–
35	Option fault	–	X	–	–
36	Mains failure	X	–	–	–
38	Internal fault	–	X	X	Contact the local Danfoss supplier.
40	Overload T27	X	–	–	–
41	Overload T29	X	–	–	–
46	Gate drive voltage fault	–	X	X	–
47	Control voltage fault	X	X	X	24 V DC is possibly overloaded.
51	AMA U _{nom} , I _{nom}	–	X	–	The setting of motor voltage, motor current, and motor power is presumably wrong. Check the settings.
52	AMA low I _{nom}	–	X	–	The motor current is too low. Check the settings.
53	AMA motor too big	–	X	–	The motor is too large to perform AMA.
54	AMA motor too small	–	X	–	The motor is too small to perform AMA.
55	AMA parameter out of range	–	X	–	The parameter values found from the motor are outside acceptable range.
56	AMA interrupted by user	–	X	–	The user has interrupted the AMA.
57	AMA time-out	–	X	–	Restart the AMA some times, until the AMA is complete. NOTICE Repeated runs can heat the motor to a level where the resistance R _s and R _r are increased. Usually, however, this increased resistance is not critical.
58	AMA internal	–	X	–	Contact the local Danfoss supplier.
59	Current limit	X	–	–	The current is higher than the value in <i>parameter 4-18 Current Limit</i> .

Alarm/ warning number	Fault text	Warning	Alarm	Trip lock	Cause of problem
60	External Interlock	–	X	–	External interlock is activated. To resume normal operation, apply 24 V DC to the terminal programmed for external interlock and reset the frequency converter. Reset via serial communication, digital I/O, or [Reset] on the LCP).
63	Mech. brake low	–	X	–	The minimum required current for opening the mechanical brake has not been reached.
65	Ctr. card temp	X	X	X	–
66	Heat sink temperature low	X	–	–	The heat sink temperature is measured as 0 °C. This result could indicate that the temperature sensor is defect. The defect causes the fan speed to increase to its maximum to cool down the power part or control card.
67	Option change	–	X	–	–
69	Pwr. Card Temp	X	X	X	The temperature sensor on the power card is either too hot or too cold.
70	Illegal FC config	–	X	X	Power size configuration fault on the power card.
80	Drive initialised	–	X	–	All parameter settings are initialized to default settings.
87	Auto DC Braking	X	–	–	The frequency converter is auto DC braking.
88	Option detection	–	X	X	–
93	Dry pump	X	X	–	–
94	End of curve	X	X	–	–
95	Broken belt	X	X	–	Torque is below the torque level set for no load, indicating a broken belt. See parameter group 22-6* <i>Broken Belt Detection</i> .
99	Locked rotor	–	X	–	The frequency converter detected a locked rotor situation. See <i>parameter 30–22 Locked Rotor Protection</i> and <i>parameter 30–23 Locked Rotor Detection Time [s]</i> .
101	Flow/pressure info missing	–	X	–	Flow/pressure information is missing.
126	Motor Rotating	–	X	–	High back EMF voltage. Stop the rotor of the PM motor.
127	Back EMF too high	X	–	–	–
200	Fire Mode	X	–	–	Fire mode is activated.
202	Fire Mode Limits Exceeded	X	–	–	Fire mode has suppressed 1 or more warranty voiding alarms.
206	Memory module	X	–	–	–
207	Memory module alarm	–	X	X	–

Table 5.2 Warnings and Alarms

5.2 Alarm Words

The alarm words, warning words, and extended status words can be readout via serial bus or optional fieldbus for diagnosis. See also *parameter 16-90 Alarm Word*, *parameter 16-92 Warning Word*, and *parameter 16-94 Ext. Status Word*.

5

Bit	Hex	Dec	Parameter 16-90 Alarm Word	Parameter 16-91 Alarm Word 2	Parameter 16-97 Alarm Word 3
0	1	1	1)	1)	1)
1	2	2	Pwr.Card Temp	Gate drive voltage fault	Memory module alarm.
2	4	4	Earth Fault	1)	1)
3	8	8	1)	1)	Synchronization fault.
4	10	16	Ctrl. Word TO	Illegal FC config.	1)
5	20	32	Over Current	1)	1)
6	40	64	1)	1)	1)
7	80	128	Motor Th. Over	1)	1)
8	100	256	Motor ETR Over	Broken Belt	1)
9	200	512	Inverter Overld.	1)	1)
10	400	1024	DC under Volt	1)	1)
11	800	2048	DC over Volt.	1)	1)
12	1000	4096	Short Circuit	External Interlock	1)
13	2000	8192	1)	1)	1)
14	4000	16384	Mains ph. loss	1)	1)
15	8000	32768	AMA Not OK	Flow/Pressure info Missing	1)
16	10000	65536	Live Zero Error	1)	1)
17	20000	131072	Internal Fault	1)	1)
18	40000	262144	1)	Fans error	1)
19	80000	524288	U phase Loss	1)	1)
20	100000	1048576	V phase Loss	1)	1)
21	200000	2097152	W phase Loss	1)	1)
22	400000	4194304	1)	Locked Rotor	1)
23	800000	8388608	24 V Supply Low	1)	1)
24	1000000	16777216	1)	1)	1)
25	2000000	33554432	1)	Current limit	1)
26	4000000	67108864	1)	1)	1)
27	8000000	134217728	1)	1)	1)
28	10000000	268435456	1)	1)	1)
29	20000000	536870912	Drive Initialized	1)	1)
30	40000000	1073741824	1)	1)	1)
31	80000000	2147483648	Mechanical brake low	1)	1)

Table 5.3 Alarm Words

1) This alarm is not used in FCP 106.

5.3 Warning Words

Bit	Hex	Dec	Parameter 16-92 Warning Word	Parameter 16-93 Warning Word 2
0	1	1	1)	1)
1	2	2	Pwr.Card Temp	1)
2	4	4	Earth Fault	1)
3	8	8	1)	1)
4	10	16	Ctrl. Word TO	1)
5	20	32	Over Current	1)
6	40	64	1)	1)
7	80	128	Motor Th. Over	1)
8	100	256	Motor ETR Over	Broken Belt
9	200	512	Inverter Overld.	1)
10	400	1024	DC under Volt	1)
11	800	2048	DC over Volt.	1)
12	1000	4096	1)	1)
13	2000	8192	1)	1)
14	4000	16384	Mains ph. loss	1)
15	8000	32768	No motor	Auto DC Braking
16	10000	65536	Live Zero Error	1)
17	20000	131072	1)	1)
18	40000	262144	1)	Fans warning
19	80000	524288	1)	1)
20	100000	1048576	1)	1)
21	200000	2097152	1)	1)
22	400000	4194304	1)	1)
23	800000	8388608	24 V Supply Low	1)
24	1000000	16777216	1)	1)
25	2000000	33554432	Current Limit	1)
26	4000000	67108864	Low temp.	1)
27	8000000	134217728	1)	1)
28	10000000	268435456	1)	1)
29	20000000	536870912	1)	1)
30	40000000	1073741824	1)	1)
31	80000000	2147483648	1)	1)

Table 5.4 Warning Words

1) This alarm is not used in FCP 106.

5.4 Extended Status Words

Bit	Hex	Dec	Parameter 16-94 Ext. Status Word	Parameter 16-95 Ext. Status Word 2
0	1	1	Ramping	Off
1	2	2	AMA running	Hand/Auto
2	4	4	Start CW/CCW	1)
3	8	8	1)	1)
4	10	16	1)	1)
5	20	32	Feedback high	1)
6	40	64	Feedback low	1)
7	80	128	Output current high	Control Ready
8	100	256	Output current low	Drive Ready
9	200	512	Output frequency high	Quick Stop
10	400	1024	Output frequency low	DC Brake
11	800	2048	1)	Stop
12	1000	4096	1)	1)
13	2000	8192	Braking	Freeze Output Request
14	4000	16384	1)	Freeze Output
15	8000	32768	OVC active	Jog Request
16	10000	65536	AC brake	Jog
17	20000	131072	1)	Start request
18	40000	262144	1)	Start
19	80000	524288	Reference high	1)
20	100000	1048576	Reference low	Start Delay
21	200000	2097152	Local Ref./Remote Ref.	Sleep
22	400000	4194304	1)	Sleep boost
23	800000	8388608	1)	Running
24	1000000	16777216	1)	Bypass
25	2000000	33554432	1)	Fire Mode
26	4000000	67108864	1)	External Interlock
27	8000000	134217728	1)	Firemodelimitexceed
28	10000000	268435456	1)	FlyStart Active
29	20000000	536870912	1)	1)
30	40000000	1073741824	1)	1)
31	80000000	2147483648	Database busy	1)

Table 5.5 Extended Status Words

1) This alarm is not used in FCP 106.

5.5 Troubleshooting

WARNING/ALARM 2, Live zero error

This warning or alarm only appears if programmed in *parameter 6-01 Live Zero Timeout Function*. The signal on 1 of the analog inputs is less than 50% of the minimum value programmed for that input. Broken wiring or a faulty device sending the signal can cause this condition.

Troubleshooting

- Check connections on all analog mains terminals.
 - Control card terminals 53 and 54 for signals, terminal 55 common.
- Check that the frequency converter programming and switch settings match the analog signal type.
- Perform an input terminal signal test.

WARNING/ALARM 3, No motor

No motor is connected to the output of the frequency converter.

WARNING/ALARM 4, Mains phase loss

A phase is missing on the supply side, or the mains voltage imbalance is too high. This message also appears for a fault in the input rectifier. Options are programmed in *parameter 14-12 Function at Mains Imbalance*.

Troubleshooting

- Check the supply voltage and supply currents to the frequency converter.

WARNING/ALARM 7, DC overvoltage

If the DC-link voltage exceeds the limit, the frequency converter trips after a certain time.

Troubleshooting

- Connect a brake resistor.
- Extend the ramp time.
- Change the ramp type.
- Activate the functions in *parameter 2-10 Brake Function*.
- Increase *parameter 14-26 Trip Delay at Inverter Fault*.
- If the alarm/warning occurs during a power sag, use kinetic back-up (*parameter 14-10 Mains Failure*).

WARNING/ALARM 8, DC under voltage

If the DC-link voltage drops below the undervoltage limit, the frequency converter trips after a fixed time delay. The time delay varies with unit size.

Troubleshooting

- Check that the supply voltage matches the frequency converter voltage.
- Perform an input voltage test.
- Perform a soft charge circuit test.

WARNING/ALARM 9, Inverter overload

The frequency converter has run with more than 100% overload for too long and is about to cut out. The counter for electronic thermal inverter protection issues a warning at 90% and trips at 100% with an alarm. The frequency converter can be reset only when the counter is 0.

Troubleshooting

- Compare the output current shown on the LCP with the frequency converter rated current.
- Compare the output current shown on the LCP with the measured motor current.
- Show the thermal frequency converter load on the LCP and monitor the value. When running above the frequency converter continuous current rating, the counter increases. When running below the frequency converter continuous current rating, the counter decreases.

WARNING/ALARM 10, Motor overload temperature

According to the electronic thermal protection (ETR), the motor is too hot. Select whether the frequency converter issues a warning or an alarm when the counter is >90% if *parameter 1-90 Motor Thermal Protection* is set to warning options, or whether the frequency converter trips when the counter reaches 100% if *parameter 1-90 Motor Thermal Protection* is set to trip options. The fault occurs when the motor runs with more than 100% overload for too long.

Troubleshooting

- Check for motor overheating.
- Check if the motor is mechanically overloaded.
- Check that the motor current set in *parameter 1-24 Motor Current* is correct.
- Ensure that the motor data in *parameters 1-20 to 1-25* are set correctly.
- If an external fan is in use, check that it is selected in *parameter 1-91 Motor External Fan*.
- Running AMA in *parameter 1-29 Automatic Motor Adaptation (AMA)* tunes the frequency converter to the motor more accurately and reduces thermal loading.

WARNING/ALARM 11, Motor thermistor over temp

Check whether the thermistor is disconnected. Select whether the frequency converter issues a warning or an alarm in *parameter 1-90 Motor Thermal Protection*.

Troubleshooting

- Check for motor overheating.
- Check if the motor is mechanically overloaded.
- When using terminal 53 or 54, check that the thermistor is connected correctly between either terminal 53 or 54 (analog voltage input) and terminal 50 (+10 V supply). Also check that the terminal switch for 53 or 54 is set for voltage.

Check that *parameter 1-93 Thermistor Source* selects terminal 53 or 54.

- When using terminal 18, 19, 31, 32, or 33 (digital inputs), check that the thermistor is connected correctly between the digital input terminal used (digital input PNP only) and terminal 50. Select the terminal to use in *parameter 1-93 Thermistor Source*.

WARNING/ALARM 13, Over current

The peak current limit of the frequency converter (approximately 145–177% of the frequency converter rated current) is exceeded. The warning lasts approximately 1.5 s, then the frequency converter trips and issues an alarm. Shock loading or quick acceleration with high-inertia loads can cause this fault. If the acceleration during ramp-up is quick, the fault can also appear after kinetic back-up. If extended mechanical brake control is selected, a trip can be reset externally.

Troubleshooting

- Remove the power and check if the motor shaft can be turned.
- Check that the motor size matches the frequency converter.
- Check that the motor data is correct in *parameters 1-20 to 1-25*.

ALARM 14, Earth fault

There is current from the output phases to ground, either in the cable between the frequency converter and the motor or in the motor itself.

Troubleshooting

- Remove power to the frequency converter and repair the ground fault.
- Check for ground faults in the motor by measuring the resistance to ground of the motor cables and the motor with a megohmmeter.

ALARM 16, Short circuit

There is short-circuiting in the motor or motor wiring.

Troubleshooting

- Remove the power to the frequency converter and repair the short circuit.

WARNING/ALARM 17, Control word timeout

There is no communication to the frequency converter. The warning is only active when *parameter 8-04 Control Word Timeout Function* is NOT set to [0] Off. If *parameter 8-04 Control Word Timeout Function* is set to [5] Stop and Trip, a warning appears, and the frequency converter ramps down to a stop and shows an alarm.

Troubleshooting

- Check the connections on the serial communication cable.
- Increase *parameter 8-03 Control Word Timeout Time*.

- Check the operation of the communication equipment.
- Verify that proper EMC installation was performed.

ALARM 30, Motor phase U missing

Motor phase U between the frequency converter and the motor is missing.

Troubleshooting

- Remove the power from the frequency converter and check motor phase U.

ALARM 31, Motor phase V missing

Motor phase V between the frequency converter and the motor is missing.

Troubleshooting

- Remove the power from the frequency converter and check motor phase V.

ALARM 32, Motor phase W missing

Motor phase W between the frequency converter and the motor is missing.

Troubleshooting

- Remove the power from the frequency converter and check motor phase W.

ALARM 38, Internal fault

When an internal fault occurs, a code number defined in *Table 5.6* is shown.

Troubleshooting

- Cycle power.
- Check that the option is properly installed.
- Check for loose or missing wiring.

Note the code number before contacting the supplier or Danfoss Service Department.

Code number	Text	Troubleshooting
0	Serial port cannot be initialized.	Contact the supplier or Danfoss Service Department.
256–258	Power EEPROM data is defective or too old.	Replace power card.
512–519	Internal fault.	Contact the supplier or Danfoss Service Department.
783	Parameter value outside of min/max limits	–
1024–1284	Internal fault.	Contact the supplier or Danfoss Service Department.
1379–2819	Internal fault.	Contact the supplier or Danfoss Service Department.
2561	Replace control card	–

Code number	Text	Troubleshooting
2820	LCP stack overflow	–
2821	Serial port overflow	–
2822	USB port overflow	–
3072–5122	Parameter value is outside its limits	–
5376–6231	Internal fault.	Contact the supplier or Danfoss Service Department.

Table 5.6 Internal Fault Codes

WARNING 40, Overload of digital output terminal 27

Check the load connected to terminal 27 or remove the short-circuit connection. Check *parameter 5-00 Digital I/O Mode* and *parameter 5-01 Terminal 27 Mode*.

WARNING 41, Overload of digital output terminal 29

Check the load connected to terminal 29 or remove the short-circuit connection. Also check *parameter 5-00 Digital I/O Mode* and *parameter 5-02 Terminal 29 Mode*.

ALARM 46, Gate drive voltage fault

The supply on the power card is out of range.

There are 3 supplies generated by the switch mode power supply (SMPS) on the power card:

- 24 V.
- 5 V.
- ± 18 V.

Troubleshooting

- Check for a defective power card.

WARNING 47, 24 V supply low

The supply on the power card is out of range.

Troubleshooting

- Check for a defective power card.

ALARM 51, AMA check U_{nom} and I_{nom}

The settings for motor voltage, motor current, and motor power are wrong.

Troubleshooting

- Check the settings in *parameters 1–20 to 1–25*.

ALARM 52, AMA low I_{nom}

The motor current is too low.

Troubleshooting

- Check the settings in *parameter 1-24 Motor Current*.

ALARM 53, AMA motor too big

The motor is too large for the AMA to operate.

ALARM 54, AMA motor too small

The motor is too small for the AMA to operate.

ALARM 55, AMA parameter out of range

AMA cannot run because the parameter values of the motor are outside of the acceptable range.

ALARM 56, AMA interrupted by user

The AMA is manually interrupted.

WARNING/ALARM 57, AMA internal fault

Try to restart AMA. Repeated restarts can overheat the motor.

ALARM 58, AMA Internal fault

Contact the Danfoss supplier.

WARNING 59, Current limit

The current is higher than the value in *parameter 4-18 Current Limit*. Ensure that motor data in *parameters 1–20 to 1–25* is set correctly. Increase the current limit if necessary. Ensure that the system can operate safely at a higher limit.

WARNING 60, External interlock

A digital input signal indicates a fault condition external to the frequency converter. An external interlock has commanded the frequency converter to trip. Clear the external fault condition. To resume normal operation, apply 24 V DC to the terminal programmed for external interlock, and reset the frequency converter.

ALARM 63, Mechanical brake low

The actual motor current has not exceeded the release brake current within the start delay time window.

ALARM 69, Power card temperature

The temperature sensor on the power card is either too hot or too cold.

Troubleshooting

- Check that the ambient operating temperature is within limits.
- Check for clogged filters.
- Check fan operation.
- Check the power card.

ALARM 80, Drive initialised to default value

Parameter settings are initialized to default settings after a manual reset. To clear the alarm, reset the unit.

ALARM 87, Auto DC braking

Auto DC braking is a protective function against overvoltage at coast.

Troubleshooting

- Check that AC line input voltage does not exceed maximum limit.

ALARM 95, Broken belt

Torque is below the torque level set for no load, indicating a broken belt. *Parameter 22-60 Broken Belt Function* is set for alarm.

Troubleshooting

- Troubleshoot the system and reset the frequency converter after clearing the fault.

ALARM 99, Blocked rotor

The rotor is blocked.

ALARM 101, Flow/pressure info missing

Sensorless-pump table is missing or wrong.

Troubleshooting

- Download sensorless-pump table again.

ALARM 126, Motor rotating

High back EMF voltage. This alarm occurs only when running AMA on a PM motor.

Troubleshooting

- Stop the rotor of the PM motor.

WARNING 127, Back EMF too high

This warning applies to PM motors only. When the back EMF exceeds $90\% \times U_{in\max}$ (overvoltage threshold), and does not drop to normal level within 5 s, this warning is reported. The warning remains until the back EMF returns to a normal level.

WARNING 200, Fire mode

The frequency converter is operating in fire mode. The warning clears when fire mode is removed. Refer to the fire mode data in the alarm log.

WARNING 202, Fire mode limits exceeded

While operating in fire mode, 1 or more alarm conditions that would normally trip the unit have been ignored. Operating in this condition voids unit warranty. Cycle power to the unit to remove the warning. Refer to the fire mode data in the alarm log.

6 Parameter Lists

6.1 Parameter Options

6.1.1 Default Settings

Changes during operation

True: The parameter can be changed while the frequency converter is in operation.

False: The parameter can only be changed when the frequency converter stops.

2-Set-up

All set-up: The parameter can be set individually in each of the 2 set-ups. 1 single parameter can have 2 different data values.

1 set-up: Data value is the same in all set-ups.

ExpressionLimit

Size-related

N/A

No default value available.

Conversion index

This number refers to a conversion figure used when writing or reading via a frequency converter.

Conv. index	100	75	74	70	67	6	5	4	3	2	1	0	-1	-2	-3	-4	-5	-6
Conv. factor	1	3600000	3600	60	1/60	1000000	100000	10000	1000	100	10	1	0.1	0.01	0.001	0.0001	0.00001	0.000001

Data type	Description	Type
2	Integer 8	Int8
3	Integer 16	Int16
4	Integer 32	Int32
5	Unsigned 8	UInt8
6	Unsigned 16	UInt16
7	Unsigned 32	UInt32
9	Visible string	VisStr
33	Normalized value 2 bytes	N2
35	Bit sequence of 16 boolean variables	V2

Table 6.1 Data Type

6.1.2 0-** Operation/Display

Par. No. #	Parameter description	Default value	4-set-up	Change during operation	Conversion index	Type
0-0* Basic Settings						
0-01	Language	[0] English	1 set-up	TRUE	-	UInt8
0-03	Regional Settings	[0] International	1 set-up	FALSE	-	UInt8
0-04	Operating State at Power-up	[0] Resume	All set-ups	TRUE	-	UInt8
0-06	GridType	ExpressionLimit	1 set-up	FALSE	-	UInt8
0-07	Auto DC Braking	[1] On	1 set-up	FALSE	-	UInt8
0-1* Set-up Operations						
0-10	Active Set-up	[1] Set-up 1	1 set-up	TRUE	-	UInt8
0-11	Programming Set-up	[9] Active Set-up	1 set-up	TRUE	-	UInt8
0-12	Link Setups	[20] Linked	All set-ups	FALSE	-	UInt8
0-2* LCP Display						
0-20	Display Line 1.1 Small	1602	All set-ups	TRUE	-	UInt16
0-21	Display Line 1.2 Small	1614	All set-ups	TRUE	-	UInt16
0-22	Display Line 1.3 Small	1610	All set-ups	TRUE	-	UInt16
0-23	Display Line 2 Large	1613	All set-ups	TRUE	-	UInt16
0-24	Display Line 3 Large	1502	All set-ups	TRUE	-	UInt16
0-3* LCP Custom Readout						
0-30	Custom Readout Unit	[1] %	1 set-up	TRUE	-	UInt8
0-31	Custom Readout Min Value	0 CustomReadoutUnit	1 set-up	TRUE	-2	Int32
0-32	Custom Readout Max Value	100 CustomReadoutUnit	1 set-up	TRUE	-2	Int32
0-37	Display Text 1	0 N/A	1 set-up	TRUE	0	VisStr[20]
0-38	Display Text 2	0 N/A	1 set-up	TRUE	0	VisStr[25]
0-39	Display Text 3	0 N/A	1 set-up	TRUE	0	VisStr[25]
0-4* LCP Keypad						
0-40	[Hand on] Key on LCP	[1] Enabled	All set-ups	TRUE	-	UInt8
0-42	[Auto on] Key on LCP	[1] Enabled	All set-ups	TRUE	-	UInt8
0-44	[Off/Reset] Key on LCP	[1] Enabled	All set-ups	TRUE	-	UInt8
0-5* Copy/Save						
0-50	LCP Copy	[0] No copy	1 set-up	FALSE	-	UInt8
0-51	Set-up Copy	[0] No copy	1 set-up	FALSE	-	UInt8
0-6* Password						
0-60	Main Menu Password	0 N/A	1 set-up	TRUE	0	UInt16

6.1.3 1-** Load and Motor

Par. No. #	Parameter description	Default value	4-set-up	Change during operation	Conversion index	Type
1-0* General Settings						
1-00	Configuration Mode	[0] Open Loop	All set-ups	TRUE	-	UInt8
1-01	Motor Control Principle	[1] VVC+	All set-ups	FALSE	-	UInt8
1-03	Torque Characteristics	[1] Variable Torque	All set-ups	FALSE	-	UInt8
1-06	Clockwise Direction	[0] Normal	1 set-up	FALSE	-	UInt8
1-08	Motor Control Bandwidth	ExpressionLimit	All set-ups	FALSE	-	UInt8
1-1* Motor Selection						
1-10	Motor Construction	[0] Asynchron	All set-ups	FALSE	-	UInt8
1-11	Motor Selection	[0] Default Motor Selection	All set-ups	FALSE	-	uint8
1-12	Motor ID	[Default Motor]	All set-ups	FALSE	0	VisStr[16]
1-14	Damping Gain	120%	All set-ups	TRUE	0	Int16
1-15	Low Speed Filter Time Const.	ExpressionLimit	All set-ups	TRUE	-2	UInt16
1-16	High Speed Filter Time Const.	ExpressionLimit	All set-ups	TRUE	-2	UInt16

Par. No. #	Parameter description	Default value	4-set-up	Change during operation	Conversion index	Type
1-17	Voltage filter time const.	ExpressionLimit	All set-ups	TRUE	-3	Uint16
1-2* Motor Data						
1-20	Motor Power	ExpressionLimit	All set-ups	FALSE	-	Uint8
1-22	Motor Voltage	ExpressionLimit	All set-ups	FALSE	0	Uint16
1-23	Motor Frequency	ExpressionLimit	All set-ups	FALSE	0	Uint16
1-24	Motor Current	ExpressionLimit	All set-ups	FALSE	-2	Uint32
1-25	Motor Nominal Speed	ExpressionLimit	All set-ups	FALSE	67	Uint16
1-26	Motor Cont. Rated Torque	ExpressionLimit	All set-ups	FALSE	-1	Uint32
1-29	Automatic Motor Adaption (AMA)	[0] Off	All set-ups	FALSE	-	Uint8
1-3* Adv. Motor Data						
1-30	Stator Resistance (Rs)	ExpressionLimit	All set-ups	FALSE	-3	Uint32
1-33	Stator Leakage Reactance (X1)	ExpressionLimit	All set-ups	FALSE	-3	Uint32
1-35	Main Reactance (Xh)	ExpressionLimit	All set-ups	FALSE	-2	Uint32
1-37	d-axis Inductance (Ld)	ExpressionLimit	All set-ups	FALSE	-6	Int32
1-38	q-axis Inductance (Lq)	ExpressionLimit	All set-ups	FALSE	-6	Int32
1-39	Motor Poles	ExpressionLimit	All set-ups	FALSE	0	Uint8
1-4* Adv. Motor Data II						
1-40	Back EMF at 1000 RPM	ExpressionLimit	All set-ups	FALSE	0	Uint16
1-44	d-axis Inductance Sat. (LdSat)	ExpressionLimit	All set-ups	FALSE	-6	Int32
1-45	q-axis Inductance Sat. (LqSat)	ExpressionLimit	All set-ups	FALSE	-6	Int32
1-46	Position Detection Gain	100%	All set-ups	TRUE	0	Uint16
1-48	Current at Min Inductance for d-axis	100%	All set-ups	FALSE	0	Int16
1-49	Current at Min Inductance for q-axis	100%	All set-ups	FALSE	0	Uint16
1-5* Load Indep. Setting						
1-50	Motor Magnetisation at Zero Speed	100%	All set-ups	TRUE	0	Uint16
1-52	Min Speed Normal Magnetising [Hz]	1 Hz	All set-ups	TRUE	-1	Uint16
1-55	U/f Characteristic - U	ExpressionLimit	All set-ups	FALSE	-1	Uint16
1-56	U/f Characteristic - F	ExpressionLimit	All set-ups	FALSE	-1	Uint16
1-6* Load Depen. Setting						
1-60	Low Speed Load Compensation	100%	All set-ups	TRUE	0	Int16
1-61	High Speed Load Compensation	100%	All set-ups	TRUE	0	Int16
1-62	Slip Compensation	ExpressionLimit	All set-ups	TRUE	0	Int16
1-63	Slip Compensation Time Constant	0.1 s	All set-ups	TRUE	-2	Uint16
1-64	Resonance Dampening	100%	All set-ups	TRUE	0	Uint16
1-65	Resonance Dampening Time Constant	0.005 s	All set-ups	TRUE	-3	Uint16
1-66	Min. Current at Low Speed	50%	All set-ups	TRUE	0	Uint32
1-7* Start Adjustments						
1-70	PM Start Mode	[0] Rotor Detection	All set-ups	TRUE	-	Uint8
1-71	Start Delay	0 s	All set-ups	TRUE	-1	Uint8
1-72	Start Function	[2] Coast/delay time	All set-ups	TRUE	-	Uint8
1-73	Flying Start	[0] Disabled	All set-ups	TRUE	-	Uint8
1-8* Stop Adjustments						
1-80	Function at Stop	[0] Coast	All set-ups	TRUE	-	Uint8
1-82	Min Speed for Function at Stop [Hz]	0 Hz	All set-ups	TRUE	-1	Uint16
1-88	AC Brake Gain	1.4 N/A	All set-ups	TRUE	-1	Uint16
1-9* Motor Temperature						
1-90	Motor Thermal Protection	ExpressionLimit	All set-ups	TRUE	-	Uint8

6.1.4 2-** Brakes

Par. No. #	Parameter description	Default value	4-set-up	Change during operation	Conversion index	Type
2-0* DC-Brake						
2-00	DC Hold/Motor Preheat Current	50%	All set-ups	TRUE	0	Uint16
2-01	DC Brake Current	50%	All set-ups	TRUE	0	Uint16
2-02	DC Braking Time	10 s	All set-ups	TRUE	-1	Uint16
2-04	DC Brake Cut In Speed	0 Hz	All set-ups	TRUE	-1	Uint16
2-06	Parking Current	100%	All set-ups	TRUE	0	Uint16
2-07	Parking Time	3 s	All set-ups	TRUE	-1	Uint16
2-1* Brake Energy Funct.						
2-10	Brake Function	[0] Off	All set-ups	TRUE	-	Uint8
2-16	AC Brake, Max current	100%	All set-ups	TRUE	-1	Uint16
2-17	Over-voltage Control	[2] Enabled	All set-ups	TRUE	-	Uint8
2-2* Mechanical Brake						
2-20	Release Brake Current	0 A	All set-ups	TRUE	-2	Uint32
2-22	Activate Brake Speed [Hz]	0 Hz	All set-ups	TRUE	-1	Uint16

6.1.5 3-** Reference/Ramps

Par. No. #	Parameter description	Default value	4-set-up	Change during operation	Conversion index	Type
3-0* Reference Limits						
3-02	Minimum Reference	0 ReferenceFeedbackUnit	All set-ups	TRUE	-3	Int32
3-03	Maximum Reference	ExpressionLimit	All set-ups	TRUE	-3	Int32
3-1* References						
3-10	Preset Reference	0%	All set-ups	TRUE	-2	Int16
3-11	Jog Speed [Hz]	5 Hz	All set-ups	TRUE	-1	Uint16
3-12	Catch up/slow Down Value	0%	All set-ups	TRUE	-2	Int16
3-14	Preset Relative Reference	0%	All set-ups	TRUE	-2	Int16
3-15	Reference 1 Source	[1] Analog Input 53	All set-ups	TRUE	-	Uint8
3-16	Reference 2 Source	[2] Analog Input 54	All set-ups	TRUE	-	Uint8
3-17	Reference 3 Source	[11] Local bus reference	All set-ups	TRUE	-	Uint8
3-4* Ramp 1						
3-41	Ramp 1 Ramp Up Time	ExpressionLimit	All set-ups	TRUE	-2	Uint32
3-42	Ramp 1 Ramp Down Time	ExpressionLimit	All set-ups	TRUE	-2	Uint32
3-5* Ramp 2						
3-51	Ramp 2 Ramp Up Time	ExpressionLimit	All set-ups	TRUE	-2	Uint32
3-52	Ramp 2 Ramp Down Time	ExpressionLimit	All set-ups	TRUE	-2	Uint32
3-8* Other Ramps						
3-80	Jog Ramp Time	ExpressionLimit	All set-ups	TRUE	-2	Uint32
3-81	Quick Stop Ramp Time	ExpressionLimit	1 set-up	TRUE	-2	Uint32
3-85	Check Valve Ramp Time	0 s	All set-ups	TRUE	-2	Uint16
3-87	Check Valve Ramp End Speed [HZ]	ExpressionLimit	All set-ups	TRUE	-1	Uint16

6.1.6 4-** Limits/Warnings

Par. No. #	Parameter description	Default value	4-set-up	Change during operation	Conversion index	Type
4-1* Motor Limits						
4-10	Motor Speed Direction	[2] Both directions	All set-ups	FALSE	-	Uint8
4-12	Motor Speed Low Limit [Hz]	0 Hz	All set-ups	FALSE	-1	Uint16
4-14	Motor Speed High Limit [Hz]	ExpressionLimit	All set-ups	FALSE	-1	Uint16
4-18	Current Limit	ExpressionLimit	All set-ups	TRUE	0	Uint16
4-19	Max Output Frequency	ExpressionLimit	All set-ups	FALSE	-1	Uint16
4-4* Adj. Warnings 2						
4-40	Warning Freq. Low	ExpressionLimit	All set-ups	TRUE	-1	uint16
4-41	Warning Freq. High	ExpressionLimit	All set-ups	TRUE	-1	uint16
4-5* Adj. Warnings						
4-50	Warning Current Low	0 A	All set-ups	TRUE	-2	Uint32
4-51	Warning Current High	ExpressionLimit	All set-ups	TRUE	-2	Uint32
4-54	Warning Reference Low	-4999 N/A	All set-ups	TRUE	-3	Int32
4-55	Warning Reference High	4999 N/A	All set-ups	TRUE	-3	Int32
4-56	Warning Feedback Low	-4999 ProcessCtrlUnit	All set-ups	TRUE	-3	Int32
4-57	Warning Feedback High	4999 ProcessCtrlUnit	All set-ups	TRUE	-3	Int32
4-58	Missing Motor Phase Function	[1] On	All set-ups	FALSE	-	Uint8
4-6* Speed Bypass						
4-61	Bypass Speed From [Hz]	0 Hz	All set-ups	TRUE	-1	Uint16
4-63	Bypass Speed To [Hz]	0 Hz	All set-ups	TRUE	-1	Uint16
4-64	Semi-Auto Bypass Set-up	[0] Off	All set-ups	TRUE	-	Uint8

6.1.7 5-** Digital In/Out

Par. No. #	Parameter description	Default value	4-set-up	Change during operation	Conversion index	Type
5-0* Digital I/O mode						
5-00	Digital Input Mode	[0] PNP	1 set-up	FALSE	-	Uint8
5-01	Terminal 27 Mode	[0] Input	All set-ups	TRUE	-	Uint8
5-02	Terminal 29 Mode	[0] Input	All set-ups	TRUE	-	Uint8
5-1* Digital Inputs						
5-10	Terminal 18 Digital Input	[8] Start	All set-ups	TRUE	-	Uint8
5-11	Terminal 19 Digital Input	[0] No operation	All set-ups	TRUE	-	Uint8
5-12	Terminal 27 Digital Input	ExpressionLimit	All set-ups	TRUE	-	Uint8
5-13	Terminal 29 Digital Input	[14] Jog	All set-ups	TRUE	-	Uint8
5-3* Digital Outputs						
5-30	Terminal 27 Digital Output	[0] No operation	All set-ups	TRUE	-	Uint8
5-31	Terminal 29 Digital Output	[0] No operation	All set-ups	TRUE	-	Uint8
5-34	On Delay, Digital Output	0.01 s	All set-ups	TRUE	-2	uint16
5-35	Off Delay, Digital Output	0.01 s	All set-ups	TRUE	-2	uint16
5-4* Relays						
5-40	Function Relay	ExpressionLimit	All set-ups	TRUE	-	Uint8
5-41	On Delay, Relay	0.01 s	All set-ups	TRUE	-2	Uint16
5-42	Off Delay, Relay	0.01 s	All set-ups	TRUE	-2	Uint16
5-5* Pulse Input						
5-50	Term. 29 Low Frequency	20 Hz	All set-ups	TRUE	0	Uint32
5-51	Term. 29 High Frequency	32000 Hz	All set-ups	TRUE	0	Uint32
5-52	Term. 29 Low Ref./Feedb. Value	0 N/A	All set-ups	TRUE	-3	Int32

Par. No. #	Parameter description	Default value	4-set-up	Change during operation	Conversion index	Type
5-53	Term. 29 High Ref./Feedb. Value	ExpressionLimit	All set-ups	TRUE	-3	Int32
5-9* Bus Controlled						
5-90	Digital & Relay Bus Control	0 N/A	All set-ups	TRUE	0	UInt32

6.1.8 6-** Analog In/Out

Par. No. #	Parameter description	Default value	4-set-up	Change during operation	Conversion index	Type
6-0* Analog I/O Mode						
6-00	Live Zero Timeout Time	10 s	All set-ups	TRUE	0	UInt8
6-01	Live Zero Timeout Function	[0] Off	All set-ups	TRUE	-	UInt8
6-1* Analog Input 53						
6-10	Terminal 53 Low Voltage	0.07 V	All set-ups	TRUE	-2	UInt16
6-11	Terminal 53 High Voltage	10 V	All set-ups	TRUE	-2	UInt16
6-12	Terminal 53 Low Current	4 mA	All set-ups	TRUE	-5	UInt16
6-13	Terminal 53 High Current	20 mA	All set-ups	TRUE	-5	UInt16
6-14	Terminal 53 Low Ref./Feedb. Value	0 N/A	All set-ups	TRUE	-3	Int32
6-15	Terminal 53 High Ref./Feedb. Value	ExpressionLimit	All set-ups	TRUE	-3	Int32
6-16	Terminal 53 Filter Time Constant	0.01 s	All set-ups	TRUE	-2	UInt16
6-19	Terminal 53 mode	[1] Voltage mode	1 set-up	TRUE	-	UInt8
6-2* Analog Input 54						
6-20	Terminal 54 Low Voltage	0.07 V	All set-ups	TRUE	-2	UInt16
6-21	Terminal 54 High Voltage	10 V	All set-ups	TRUE	-2	UInt16
6-22	Terminal 54 Low Current	4 mA	All set-ups	TRUE	-5	UInt16
6-23	Terminal 54 High Current	20 mA	All set-ups	TRUE	-5	UInt16
6-24	Terminal 54 Low Ref./Feedb. Value	0 N/A	All set-ups	TRUE	-3	Int32
6-25	Terminal 54 High Ref./Feedb. Value	ExpressionLimit	All set-ups	TRUE	-3	Int32
6-26	Terminal 54 Filter Time Constant	0.01 s	All set-ups	TRUE	-2	UInt16
6-29	Terminal 54 mode	[1] Voltage mode	1 set-up	TRUE	-	UInt8
6-7* Analog/Digital Output 45						
6-70	Terminal 45 Mode	[0] 0-20 mA	All set-ups	TRUE	-	UInt8
6-71	Terminal 45 Analog Output	[0] No operation	All set-ups	TRUE	-	UInt8
6-72	Terminal 45 Digital Output	[0] No operation	All set-ups	TRUE	-	UInt8
6-73	Terminal 45 Output Min Scale	0%	All set-ups	TRUE	-2	UInt16
6-74	Terminal 45 Output Max Scale	100%	All set-ups	TRUE	-2	UInt16
6-76	Terminal 45 Output Bus Control	0 N/A	All set-ups	TRUE	0	UInt16
6-9* Analog/Digital Output 42						
6-90	Terminal 42 Mode	[0] 0-20 mA	All set-ups	TRUE	-	UInt8
6-91	Terminal 42 Analog Output	[0] No operation	All set-ups	TRUE	-	UInt8
6-92	Terminal 42 Digital Output	[0] No operation	All set-ups	TRUE	-	UInt8
6-93	Terminal 42 Output Min Scale	0%	All set-ups	TRUE	-2	UInt16
6-94	Terminal 42 Output Max Scale	100%	All set-ups	TRUE	-2	UInt16
6-96	Terminal 42 Output Bus Control	0 N/A	All set-ups	TRUE	0	UInt16

6.1.9 8-** Comm. and Options

Par. No. #	Parameter description	Default value	4-set-up	Change during operation	Conversion index	Type
8-0* General Settings						
8-01	Control Site	[0] Digital and ctrl.word	All set-ups	TRUE	-	Uint8
8-02	Control Source	ExpressionLimit	All set-ups	TRUE	-	Uint8
8-03	Control Timeout Time	1 s	1 set-up	TRUE	-1	Uint16
8-04	Control Timeout Function	[0] Off	1 set-up	TRUE	-	Uint8
8-07	Diagnosis Trigger	[0] Disable	1 set-up	TRUE	-	Uint8
8-1* Ctrl. Word Settings						
8-10	Control Word Profile	[0] FC profile	All set-ups	TRUE	-	Uint8
8-14	Configurable Control Word CTW	[1] Profile default	All set-ups	TRUE	-	Uint8
8-19	Product Code	ExpressionLimit	1 set-up	TRUE	0	Uint32
8-3* FC Port Settings						
8-30	Protocol	[0] FC	1 set-up	TRUE	-	Uint8
8-31	Address	1 N/A	1 set-up	TRUE	0	Uint8
8-32	Baud Rate	ExpressionLimit	1 set-up	TRUE	-	Uint8
8-33	Parity / Stop Bits	ExpressionLimit	1 set-up	TRUE	-	Uint8
8-35	Minimum Response Delay	0.01 s	1 set-up	TRUE	-3	Uint16
8-36	Maximum Response Delay	ExpressionLimit	1 set-up	TRUE	-3	Uint16
8-37	Maximum Inter-char delay	0.025 s	1 set-up	TRUE	-3	Uint16
8-4* FC MC protocol set						
8-40	Telegram Selection	[1] Standard telegram 1	2 set-ups	TRUE	-	Uint8
8-42	PCD Write Configuration	ExpressionLimit	2 set-ups	TRUE	-	Uint8
8-43	PCD Read Configuration	ExpressionLimit	1 set-up	TRUE	-	uint8
8-5* Digital/Bus						
8-50	Coasting Select	[3] Logic OR	All set-ups	TRUE	-	Uint8
8-51	Quick Stop Select	[3] Logic OR	All set-ups	TRUE	-	Uint8
8-52	DC Brake Select	[3] Logic OR	All set-ups	TRUE	-	Uint8
8-53	Start Select	[3] Logic OR	All set-ups	TRUE	-	Uint8
8-54	Reversing Select	[0] Digital input	All set-ups	TRUE	-	Uint8
8-55	Set-up Select	[3] Logic OR	All set-ups	TRUE	-	Uint8
8-56	Preset Reference Select	[3] Logic OR	All set-ups	TRUE	-	Uint8
8-57	Profidrive OFF2 Select	[3] Logic OR	All set-ups	TRUE	-	Uint8
8-58	Profidrive OFF3 Select	[3] Logic OR	All set-ups	TRUE	-	Uint8
8-7* BACnet						
8-70	BACnet Device Instance	1 N/A	1 set-up	TRUE	0	Uint32
8-72	MS/TP Max Masters	127 N/A	1 set-up	TRUE	0	Uint8
8-73	MS/TP Max Info Frames	1 N/A	1 set-up	TRUE	0	Uint16
8-74	"I am" Service	[0] Send at power-up	1 set-up	TRUE	-	Uint8
8-75	Initialisation Password	[admin]	1 set-up	TRUE	0	VisStr[20]
8-79	Protocol Firmware version	ExpressionLimit	1 set-up	FALSE	-2	Uint16
8-8* FC Port Diagnostics						
8-80	Bus Message Count	0 N/A	1 set-up	TRUE	0	Uint32
8-81	Bus Error Count	0 N/A	1 set-up	TRUE	0	Uint32
8-82	Slave Messages Rcvd	0 N/A	1 set-up	TRUE	0	Uint32
8-83	Slave Error Count	0 N/A	1 set-up	TRUE	0	Uint32
8-84	Slave Messages Sent	0 N/A	1 set-up	TRUE	0	Uint32
8-85	Slave Timeout Errors	0 N/A	1 set-up	TRUE	0	Uint32
8-88	Reset FC port Diagnostics	[0] Do not reset	1 set-up	TRUE	-	Uint8
8-9* Bus Jog / Feedback						
8-90	Bus Jog 1 Speed	100 RPM	All set-ups	TRUE	67	Uint16
8-91	Bus Jog 2 Speed	200 RPM	All set-ups	TRUE	67	Uint16

Par. No. #	Parameter description	Default value	4-set-up	Change during operation	Conversion index	Type
8-94	Bus Feedback 1	0 N/A	All set-ups	TRUE	0	Int16

6.1.10 9-** PROFIdrive

Par. No. #	Parameter description	Default value	4-set-up	Change during operation	Conversion index	Type
9-00	Setpoint	0 N/A	All set-ups	TRUE	0	Uint16
9-07	Actual Value	0 N/A	All set-ups	FALSE	0	Uint16
9-15	PCD Write Configuration	ExpressionLimit	1 set-up	TRUE	-	Uint16
9-16	PCD Read Configuration	ExpressionLimit	1 set-up	TRUE	-	Uint16
9-18	Node Address	126 N/A	1 set-up	TRUE	0	Uint8
9-19	Drive Unit System Number	1038 N/A	All set-ups	TRUE	0	Uint16
9-22	Telegram Selection	[100] None	1 set-up	TRUE	-	Uint8
9-23	Parameters for Signals	0	All set-ups	TRUE	-	Uint16
9-27	Parameter Edit	[1] Enabled	1 set-up	FALSE	-	Uint16
9-28	Process Control	[1] Enable cyclic master	1 set-up	FALSE	-	Uint8
9-44	Fault Message Counter	0 N/A	All set-ups	TRUE	0	Uint16
9-45	Fault Code	0 N/A	All set-ups	TRUE	0	Uint16
9-47	Fault Number	0 N/A	All set-ups	TRUE	0	Uint16
9-52	Fault Situation Counter	0 N/A	All set-ups	TRUE	0	Uint16
9-53	Profibus Warning Word	0 N/A	All set-ups	TRUE	0	V2
9-63	Actual Baud Rate	[255] No baud rate found	All set-ups	TRUE	-	Uint8
9-64	Device Identification	0 N/A	All set-ups	TRUE	0	Uint16
9-65	Profile Number	0 N/A	All set-ups	TRUE	0	OctStr[2]
9-67	Control Word 1	0 N/A	All set-ups	TRUE	0	V2
9-68	Status Word 1	0 N/A	All set-ups	TRUE	0	V2
9-70	Edit Set-up	[9] Active Set-up	1 set-up	TRUE	-	Uint8
9-71	Profibus Save Data Values	[0] Off	All set-ups	TRUE	-	Uint8
9-72	ProfibusDriveReset	[0] No action	1 set-up	FALSE	-	Uint8
9-75	DO Identification	0 N/A	All set-ups	TRUE	0	Uint16
9-80	Defined Parameters (1)	0 N/A	All set-ups	FALSE	0	Uint16
9-81	Defined Parameters (2)	0 N/A	All set-ups	FALSE	0	Uint16
9-82	Defined Parameters (3)	0 N/A	All set-ups	FALSE	0	Uint16
9-83	Defined Parameters (4)	0 N/A	All set-ups	FALSE	0	Uint16
9-84	Defined Parameters (5)	0 N/A	All set-ups	FALSE	0	Uint16
9-85	Defined Parameters (6)	0 N/A	All set-ups	FALSE	0	Uint16
9-90	Changed Parameters (1)	0 N/A	All set-ups	FALSE	0	Uint16
9-91	Changed Parameters (2)	0 N/A	All set-ups	FALSE	0	Uint16
9-92	Changed Parameters (3)	0 N/A	All set-ups	FALSE	0	Uint16
9-93	Changed Parameters (4)	0 N/A	All set-ups	FALSE	0	Uint16
9-94	Changed Parameters (5)	0 N/A	All set-ups	FALSE	0	Uint16
9-99	Profibus Revision Counter	0 N/A	All set-ups	TRUE	0	Uint16

6.1.11 13-** Smart Logic

Par. No. #	Parameter description	Default value	4-set-up	Change during operation	Conversion index	Type
13-0* SLC Settings						
13-00	SL Controller Mode	[0] Off	1 set-up	TRUE	-	Uint8
13-01	Start Event	[39] Start command	1 set-up	TRUE	-	Uint8
13-02	Stop Event	[40] Drive stopped	1 set-up	TRUE	-	Uint8
13-03	Reset SLC	[0] Do not reset SLC	1 set-up	TRUE	-	Uint8
13-1* Comparators						
13-10	Comparator Operand	[0] Disabled	1 set-up	TRUE	-	Uint8
13-11	Comparator Operator	[1] Approx.Equal (~)	1 set-up	TRUE	-	Uint8
13-12	Comparator Value	0 N/A	1 set-up	TRUE	-3	Int32
13-2* Timers						
13-20	SL Controller Timer	0 s	1 set-up	TRUE	-2	Uint32
13-4* Logic Rules						
13-40	Logic Rule Boolean 1	[0] False	1 set-up	TRUE	-	Uint8
13-41	Logic Rule Operator 1	[0] Disabled	1 set-up	TRUE	-	Uint8
13-42	Logic Rule Boolean 2	[0] False	1 set-up	TRUE	-	Uint8
13-43	Logic Rule Operator 2	[0] Disabled	1 set-up	TRUE	-	Uint8
13-44	Logic Rule Boolean 3	[0] False	1 set-up	TRUE	-	Uint8
13-5* States						
13-51	SL Controller Event	[0] False	1 set-up	TRUE	-	Uint8
13-52	SL Controller Action	[0] Disabled	1 set-up	TRUE	-	Uint8

6.1.12 14-** Special Functions

Par. No. #	Parameter description	Default value	4-set-up	Change during operation	Conversion index	Type
14-0* Inverter Switching						
14-01	Switching Frequency	ExpressionLimit	All set-ups	TRUE	-	Uint8
14-03	Overmodulation	[0] Off	All set-ups	FALSE	-	Uint8
14-07	Dead Time Compensation Level	ExpressionLimit	All set-ups	FALSE	0	Uint8
14-08	Damping Gain Factor	ExpressionLimit	All set-ups	TRUE	0	Uint8
14-09	Dead Time Bias Current Level	ExpressionLimit	All set-ups	FALSE	0	Uint8
14-1* Mains On/Off						
14-10	Mains Failure	[0] No function	All set-ups	FALSE	-	Uint8
14-11	Mains Voltage at Mains Fault	ExpressionLimit	All set-ups	TRUE	0	Uint16
14-12	Function at Mains Imbalance	[0] Trip	1 set-up	TRUE	-	Uint8
14-2* Reset Functions						
14-20	Reset Mode	[0] Manual reset	All set-ups	TRUE	-	Uint8
14-21	Automatic Restart Time	10 s	All set-ups	TRUE	0	Uint16
14-22	Operation Mode	[0] Normal operation	1 set-up	TRUE	-	Uint8
14-27	Action At Inverter Fault	[1] Warning	All set-ups	TRUE	-	Uint8
14-28	Production Settings	[0] No action	1 set-up	FALSE	-	Uint8
14-29	Service Code	0 N/A	1 set-up	TRUE	0	Uint32
14-3* Current Limit Ctrl.						
14-30	Current Lim Ctrl, Proportional Gain	100%	All set-ups	TRUE	0	Uint16
14-31	Current Lim Ctrl, Integration Time	ExpressionLimit	All set-ups	TRUE	-3	Uint16
14-32	Current Lim Ctrl, Filter Time	ExpressionLimit	All set-ups	TRUE	-4	Uint16
14-4* Energy Optimising						
14-40	VT Level	90%	All set-ups	FALSE	0	Uint8

Par. No. #	Parameter description	Default value	4-set-up	Change during operation	Conversion index	Type
14-41	AEO Minimum Magnetisation	66%	All set-ups	FALSE	0	UInt8
14-44	d-axis current optimization for IPM	100%	All set-ups	TRUE	0	UInt8
14-5* Environment						
14-51	DC-Link Voltage Compensation	[1] On	All set-ups	FALSE	-	UInt8
14-55	Output Filter	[0] No Filter	1 set-up	FALSE	-	UInt8
14-6* Auto Derate						
14-61	Function at Inverter Overload	[0] Trip	All set-ups	TRUE	-	UInt8
14-63	Min Switch Frequency	[2] 2.0 kHz	1 set-up	FALSE	-	UInt8
14-64	Dead Time Compensation Zero Current Level	[0] Disabled	All set-ups	FALSE	-	UInt8
14-65	Speed Derate Dead Time Compensation	ExpressionLimit	All set-ups	FALSE	0	UInt16
14-8* Options						
14-89	Option Detection	[0] Protect Option Config.	1 set-up	TRUE	-	UInt8
14-9* Fault Settings						
14-90	Fault Level	[3] Trip lock	All set-ups	FALSE	-	UInt8

6

6.1.13 15-** Drive Information

Par. No. #	Parameter description	Default value	4-set-up	Change during operation	Conversion index	Type
15-0* Operating Data						
15-00	Operating hours	0 h	1 set-up	TRUE	74	UInt32
15-01	Running Hours	0 h	1 set-up	TRUE	74	UInt32
15-02	kWh Counter	0 kWh	1 set-up	TRUE	75	UInt32
15-03	Power Up's	0 N/A	1 set-up	TRUE	0	UInt32
15-04	Over Temp's	0 N/A	1 set-up	TRUE	0	UInt16
15-05	Over Volt's	0 N/A	1 set-up	TRUE	0	UInt16
15-06	Reset kWh Counter	[0] Do not reset	1 set-up	TRUE	-	UInt8
15-07	Reset Running Hours Counter	[0] Do not reset	1 set-up	TRUE	-	UInt8
15-3* Alarm Log						
15-30	Alarm Log: Error Code	0 N/A	1 set-up	TRUE	0	UInt8
15-31	InternalFaultReason	0 N/A	1 set-up	TRUE	0	Int16
15-4* Drive Identification						
15-40	FC Type	0 N/A	1 set-up	FALSE	0	VisStr[6]
15-41	Power Section	0 N/A	1 set-up	FALSE	0	VisStr[20]
15-42	Voltage	0 N/A	1 set-up	FALSE	0	VisStr[20]
15-43	Software Version	0 N/A	1 set-up	FALSE	0	VisStr[20]
15-44	Ordered TypeCode	0 N/A	1 set-up	FALSE	0	VisStr[40]
15-45	Actual Typecode String	0 N/A	All set-ups	FALSE	0	VisStr[40]
15-46	Drive Ordering No	0 N/A	1 set-up	FALSE	0	VisStr[8]
15-48	LCP Id No	0 N/A	1 set-up	FALSE	0	VisStr[21]
15-49	SW ID Control Card	0 N/A	1 set-up	FALSE	0	VisStr[21]
15-50	SW ID Power Card	0 N/A	1 set-up	FALSE	0	VisStr[21]
15-51	Drive Serial Number	0 N/A	1 set-up	FALSE	0	VisStr[10]
15-52	OEM Information	0 N/A	1 set-up	FALSE	0	VisStr[40]
15-53	Power Card Serial Number	0 N/A	1 set-up	FALSE	0	VisStr[20]
15-57	File version	0 N/A	1 set-up	FALSE	0	UInt8
15-59	File name	0 N/A	1 set-up	FALSE	0	VisStr[16]
15-6* Option Ident						
15-60	Option Mounted	ExpressionLimit	All set-ups	FALSE	0	VisStr[30]
15-61	Option SW Version	ExpressionLimit	All set-ups	FALSE	0	VisStr[20]

Par. No. #	Parameter description	Default value	4-set-up	Change during operation	Conversion index	Type
15-62	Option Ordering No	ExpressionLimit	All set-ups	FALSE	0	VisStr[8]
15-63	Option Serial No	ExpressionLimit	All set-ups	FALSE	0	VisStr[18]
15-70	Option in Slot A	0 N/A	All set-ups	FALSE	0	VisStr[30]
15-71	Slot A Option SW Version	0 N/A	All set-ups	FALSE	0	VisStr[20]
15-9* Parameter Info						
15-92	Defined Parameters	0 N/A	1 set-up	TRUE	0	Uint16
15-97	Application Type	0 N/A	1 set-up	TRUE	0	Uint32
15-98	Drive Identification	0 N/A	1 set-up	FALSE	0	VisStr[56]

6.1.14 16-** Data Readouts

Par. No. #	Parameter description	Default value	4-set-up	Change during operation	Conversion index	Type
16-0* General Status						
16-00	Control Word	0 N/A	1 set-up	TRUE	0	Uint16
16-01	Reference [Unit]	0 ReferenceFeedbackUnit	1 set-up	TRUE	-3	Int32
16-02	Reference [%]	0%	1 set-up	TRUE	-1	Int16
16-03	Status Word	0 N/A	1 set-up	TRUE	0	Uint16
16-05	Main Actual Value [%]	0%	1 set-up	TRUE	-2	Int16
16-09	Custom Readout	0 CustomReadoutUnit	1 set-up	TRUE	-2	Int32
16-1* Motor Status						
16-10	Power [kW]	0 kW	1 set-up	TRUE	-3	Uint32
16-11	Power [hp]	0 hp	1 set-up	TRUE	-3	Uint32
16-12	Motor Voltage	0 V	1 set-up	TRUE	-1	Uint32
16-13	Frequency	0 Hz	1 set-up	TRUE	-1	Uint32
16-14	Motor current	0 A	1 set-up	TRUE	-2	Uint16
16-15	Frequency [%]	0%	1 set-up	TRUE	-1	Uint16
16-16	Torque [Nm]	0 Nm	All set-ups	FALSE	-1	Int32
16-18	Motor Thermal	0%	1 set-up	TRUE	0	Uint8
16-22	Torque [%]	0%	All set-ups	FALSE	0	Int16
16-26	Power Filtered [kW]	0 kW	1 set-up	FALSE	0	Int32
16-27	Power Filtered [hp]	0 hp	1 set-up	FALSE	-3	Int32
16-3* Drive Status						
16-30	DC Link Voltage	0 V	1 set-up	TRUE	0	Uint32
16-34	Heatsink Temp.	0 °C	1 set-up	TRUE	100	Int8
16-35	Inverter Thermal	0%	1 set-up	TRUE	0	Uint8
16-36	Inv. Nom. Current	0 A	1 set-up	TRUE	-2	Uint16
16-37	Inv. Max. Current	0 A	1 set-up	TRUE	-2	Uint16
16-38	SL Controller State	0 N/A	1 set-up	TRUE	0	Uint8
16-39	Control Card Temp.	0 °C	All set-ups	FALSE	100	Uint16
16-5* Ref. & Feedb.						
16-50	External Reference	0%	1 set-up	TRUE	-1	Int16
16-52	Feedback[Unit]	0 ProcessCtrlUnit	1 set-up	TRUE	-3	Int32
16-6* Inputs & Outputs						
16-60	Digital Input	0 N/A	1 set-up	TRUE	0	Uint16
16-61	Terminal 53 Setting	[0] Current mode	1 set-up	TRUE	-	Uint8
16-62	Analog Input AI53	1 N/A	1 set-up	TRUE	-2	Uint16
16-63	Terminal 54 Setting	[0] Current mode	1 set-up	TRUE	-	Uint8
16-64	Analog Input AI54	1 N/A	1 set-up	TRUE	-2	Uint16
16-65	Analog Output AO42 [mA]	0 mA	1 set-up	TRUE	-2	Uint16

Par. No. #	Parameter description	Default value	4-set-up	Change during operation	Conversion index	Type
16-66	Digital Output	0 N/A	1 set-up	TRUE	0	VisStr[4]
16-67	Pulse Input #29 [Hz]	0 N/A	All set-ups	FALSE	0	Int32
16-71	Relay Output [bin]	0 N/A	1 set-up	TRUE	0	UInt16
16-72	Counter A	0 N/A	1 set-up	TRUE	0	Int16
16-73	Counter B	0 N/A	1 set-up	TRUE	0	Int16
16-79	Analog Output AO45	0 mA	1 set-up	TRUE	-2	UInt16
16-8* Fieldbus & FC Port						
16-80	Fieldbus CTW 1	0 N/A	1 set-up	TRUE	0	UInt16
16-82	Fieldbus REF 1	0 N/A	1 set-up	TRUE	0	Int16
16-84	Comm. Option STW	0 N/A	1 set-up	TRUE	0	UInt16
16-85	FC Port CTW 1	1084 N/A	1 set-up	FALSE	0	uint16
16-86	FC Port REF 1	0 N/A	1 set-up	TRUE	0	Int16
16-9* Diagnosis Readouts						
16-90	Alarm Word	0 N/A	1 set-up	TRUE	0	UInt32
16-91	Alarm Word 2	0 N/A	1 set-up	TRUE	0	UInt32
16-92	Warning Word	0 N/A	1 set-up	TRUE	0	UInt32
16-93	Warning Word 2	0 N/A	1 set-up	TRUE	0	UInt32
16-94	Ext. Status Word	0 N/A	1 set-up	TRUE	0	UInt32
16-95	Ext. Status Word 2	0 N/A	1 set-up	TRUE	0	UInt32
16-97	Alarm Word 3	0 N/A	1 set-up	TRUE	0	UInt32

6.1.15 18-** Info & Readouts

Par. No. #	Parameter description	Default value	4-set-up	Change during operation	Conversion index	Type
18-1* Fire Mode Log						
18-10	FireMode Log:Event	0 N/A	1 set-up	TRUE	0	UInt8
18-5* Ref. & Feedb.						
18-50	Sensorless Readout [unit]	0 SensorlessUnit	1 set-up	FALSE	-3	Int32
18-51	Memory Module Warning Reason	0 N/A	1 set-up	TRUE	0	uint32
18-52	Memory Module ID	0 N/A	All set-ups	FALSE	0	VisStr[18]
18-53	Memory Module Function	[1] Enabled	1 set-up	TRUE	-	UInt8

6.1.16 20-** Drive Closed Loop

Par. No. #	Parameter description	Default value	4-set-up	Change during operation	Conversion index	Type
20-0* Feedback						
20-00	Feedback 1 Source	[0] No function	All set-ups	TRUE	-	UInt8
20-01	Feedback 1 Conversion	[0] Linear	All set-ups	TRUE	-	UInt8
20-12	Reference/Feedback Unit	ExpressionLimit	All set-ups	TRUE	-	UInt8
20-2* Feedback/Setpoint						
20-21	Setpoint 1	0 ProcessCtrlUnit	All set-ups	TRUE	-3	Int32
20-6* Sensorless						
20-60	Sensorless Unit	ExpressionLimit	All set-ups	TRUE	-	UInt8
20-69	Sensorless Information	0 N/A	1 set-up	TRUE	0	VisStr[25]
20-8* PI Basic Settings						
20-81	PI Normal/ Inverse Control	[0] Normal	All set-ups	TRUE	-	UInt8
20-83	PI Start Speed [Hz]	0 Hz	All set-ups	TRUE	-1	UInt16

Par. No. #	Parameter description	Default value	4-set-up	Change during operation	Conversion index	Type
20-84	On Reference Bandwidth	5%	All set-ups	TRUE	0	Uint8
20-9* PI Controller						
20-91	PI Anti Windup	[1] On	All set-ups	TRUE	-	Uint8
20-93	PI Proportional Gain	0.50 N/A	All set-ups	TRUE	-2	Uint16
20-94	PI Integral Time	20 s	All set-ups	TRUE	-2	Uint32
20-97	PI Feed Forward Factor	0%	All set-ups	TRUE	0	Uint16

6.1.17 22-** Appl. Functions

Par. No. #	Parameter description	Default value	4-set-up	Change during operation	Conversion index	Type
22-0* Miscellaneous						
22-01	Power Filter Time	0.50 s	2 set-ups	TRUE	-2	Uint16
22-02	Sleepmode CL Control Mode	[0] Normal	All set-ups	TRUE	-	Uint8
22-2* No-Flow Detection						
22-26	Dry Pump Function	[0] Off	All set-ups	TRUE	-	Uint8
22-27	Dry Pump Delay	10 s	All set-ups	TRUE	0	Uint16
22-3* No-Flow Power Tuning						
22-38	High Speed Power [kW]	ExpressionLimit	All set-ups	TRUE	1	Uint32
22-4* Sleep Mode						
22-40	Minimum Run Time	10 s	All set-ups	TRUE	0	Uint16
22-41	Minimum Sleep Time	10 s	All set-ups	TRUE	0	Uint16
22-43	Wake-Up Speed [Hz]	10 N/A	All set-ups	TRUE	-1	Uint16
22-44	Wake-Up Ref./FB Diff	10%	All set-ups	TRUE	0	Uint8
22-45	Setpoint Boost	0%	All set-ups	TRUE	0	Int8
22-46	Maximum Boost Time	60 s	All set-ups	TRUE	0	Uint16
22-47	Sleep Speed [Hz]	0 N/A	All set-ups	TRUE	-1	Uint16
22-48	Sleep Delay Time	0 s	All set-ups	TRUE	0	Uint16
22-49	Wake-Up Delay Time	0 s	All set-ups	TRUE	0	Uint16
22-5* End of Curve						
22-50	End of Curve Function	[0] Off	All set-ups	TRUE	-	Uint8
22-51	End of Curve Delay	10 s	All set-ups	TRUE	0	Uint16
22-6* Broken Belt Detection						
22-60	Broken Belt Function	[0] Off	All set-ups	TRUE	-	Uint8
22-61	Broken Belt Torque	10%	All set-ups	TRUE	0	Uint8
22-62	Broken Belt Delay	10 s	All set-ups	TRUE	0	Uint16
22-8* Flow Compensation						
22-80	Flow Compensation	[0] Disabled	All set-ups	TRUE	-	Uint8
22-81	Square-linear Curve Approximation	100%	All set-ups	TRUE	0	Uint8
22-82	Work Point Calculation	[0] Disabled	All set-ups	TRUE	-	Uint8
22-84	Speed at No-Flow [Hz]	0 Hz	All set-ups	TRUE	-1	Uint16
22-86	Speed at Design Point [Hz]	ExpressionLimit	All set-ups	TRUE	-1	Uint16
22-87	Pressure at No-Flow Speed	0 N/A	All set-ups	TRUE	-3	Uint32
22-88	Pressure at Rated Speed	999999.999 N/A	All set-ups	TRUE	-3	Uint32
22-89	Flow at Design Point	0 N/A	All set-ups	TRUE	-3	Int32
22-90	Flow at Rated Speed	0 N/A	All set-ups	TRUE	-3	Int32

6.1.18 24-** Appl. Functions 2

Par. No. #	Parameter description	Default value	4-set-up	Change during operation	Conversion index	Type
24-0* Fire Mode						
24-00	FM Function	[0] Disabled	1 set-up	TRUE	-	UInt8
24-05	FM Preset Reference	0%	All set-ups	TRUE	0	Int16
24-09	FM Alarm Handling	[1] Trip, Crit.Alarms	1 set-up	FALSE	-	UInt8
24-1* Drive Bypass						
24-10	Drive Bypass Function	[0] Disabled	1 set-up	TRUE	-	UInt8
24-11	Drive Bypass Delay Time	0 s	1 set-up	TRUE	0	UInt16

6.1.19 30-** Special Features

Par. No. #	Parameter description	Default value	4-set-up	Change during operation	Conversion index	Type
30-2* Adv. Start Adjust						
30-20	High Starting Torque Time [s]	ExpressionLimit	All set-ups	TRUE	-2	UInt16
30-21	High Starting Torque Current [%]	ExpressionLimit	All set-ups	TRUE	-1	UInt32
30-22	Locked Rotor Detection	[1] On	All set-ups	TRUE	-	UInt8
30-23	Locked Rotor Detection Time [s]	1 s	All set-ups	TRUE	-2	UInt8

Index

A

Abbreviations..... 5

Action at inverter fault..... 90

Active set-up..... 35

AEO..... 5, 91
 see also *Automatic energy optimization*

Alarm..... 117

Alarm log..... 93

Alarm log: error code..... 93

Alarm word..... 99

Alarm word 2..... 99

Alarm/warning code list..... 117

AMA..... 5, 118, 123, 125
 see also *Automatic motor adaptation*

Analog input AI53..... 98

Analog input AI54..... 98

Analog output AO42 [mA]..... 98

Analog output AO45..... 99

Analog signal..... 123

Auto DC braking IT..... 35

Auto derate..... 91

Automatic energy optimization..... 5
 see also *AEO*

Automatic motor adaptation..... 5, 44, 118
 see also *AMA*

Automatic restart time..... 90

B

BACnet..... 75

BACnet device instance..... 75

Baud rate..... 72

Brake
 control..... 124
 resistor..... 6, 123

Broken belt..... 119

Broken-belt delay..... 110

Broken-belt detection..... 110

Broken-belt function..... 110

Broken-belt torque..... 110

Bus feedback..... 76

C

Changes made..... 9

Closed loop..... 40

Closed-loop set-up wizard..... 9, 11

Coast inverse..... 58

Coasting..... 31, 32

Coasting select..... 73

Comparator
 Comparator..... 84
 operand..... 84
 operator..... 84
 value..... 84

Control
 card..... 123
 site..... 71
 timeout time..... 71
 word..... 30, 96
 word timeout..... 124

Conventions..... 6

Copy parameter setting..... 13

Counter A..... 99

Counter B..... 99

Current
 limit..... 6, 55
 rating..... 123
 Output current..... 123
 Rated output current..... 6

Current limit control..... 90

Custom readout..... 96

Custom readout unit..... 38

D

Data readouts..... 96

Data transfer..... 13

Data type, supported..... 22

DC brake..... 31

DC braking time..... 50

DC hold/motor preheat current..... 50

DC overvolt..... 118

DC undervolt..... 118

DC-brake current..... 50

DC-brake cut-in speed..... 50

DC-link compensation..... 91

Default setting..... 127

DeviceNet..... 5

Diagnostics and troubleshooting..... 117

Digital input function..... 58

Digital input mode..... 58

Digital output..... 98

Display
 Display..... 8

Document version..... 5

Drive bypass..... 114

Dry pump function..... 106

E		H	
Efficiency.....	6	Hand start.....	58
End of curve.....	109	Heat sink temperature.....	97
Energy optimizing.....	91	Hold output frequency.....	31
Environment.....	91		
ETR.....	6, 118	I	
<i>see also Electronic thermal relay</i>		IND.....	21
Extended status word.....	100, 122	Index (IND).....	21
Extended status word 2.....	100	Indicator light.....	8
External interlock.....	58, 119	Initialization.....	90
External reference.....	98	Initialize frequency converter.....	13
		Inputs	
F		Analog input.....	123
Fault		Digital input.....	58, 98, 124
Earth fault.....	118	Digital input function.....	58
Gate drive voltage.....	125	Digital input mode.....	58
Ground fault.....	118, 124	Introduction.....	5
Fault settings.....	92	Inverter maximum current.....	97
FC closed-loop.....	102	Inverter nominal current.....	97
FC port diagnostic.....	75	Inverter overload.....	118
FC port setting.....	72	Inverter switching.....	89
FC profile		Inverter thermal.....	97
FC profile.....	30		
Protocol overview.....	17	J	
FC with Modbus RTU.....	17	Jog.....	31, 58
Feedback.....	102	Jog ramp time.....	54
Feedback 1 conversion.....	102	Jog speed [Hz].....	52
Feedback 1 source.....	102		
Fieldbus & drive port.....	99	K	
Fieldbus & FC port.....	99	KWh counter.....	93
Fire mode.....	58, 119, 126		
Fire mode log.....	101	L	
Flow compensation.....	110	Language.....	34
FM function.....	113	Latched start.....	58
Freeze output.....	58	LCP.....	6, 8
Frequency.....	97	<i>see also Local control panel</i>	
Frequency [%].....	97	LCP copy.....	13, 39
Frequency converter identification.....	93	LCP custom readout.....	37
Function at mains imbalance.....	90	Link set-up.....	35
Function at stop.....	48	Literature.....	5
Function codes.....	27	Live zero.....	66
Function relay.....	62	Load compensation.....	40
		Local control panel.....	6, 8
G		<i>see also LCP</i>	
GLCP.....	8	Local reference.....	34
Grid type.....	34	Logic rule.....	85
		Logic rule boolean 2.....	85

Logic rule boolean 3.....	86
Logic rule operator 1.....	85
Logic rule operator 2.....	86

M

Main actual value.....	96
Main menu.....	9
Main reactance.....	44, 45
Mains	
failure.....	89
imbalance.....	117
on/off.....	89
phase loss.....	117
voltage at mains fault.....	89
Maximum boost time.....	109
Maximum output frequency.....	55
Maximum reference.....	52
Maximum response delay.....	72
MC protocol set.....	72
Menu key.....	8
Minimum reference.....	52
Minimum response delay.....	72
Minimum sleep time.....	108
Modbus.....	5
Modbus communication.....	17
Modbus exception code.....	27
Modbus RTU.....	24
Modbus RTU overview.....	23
Modulation.....	5, 6

Motor

High back EMF.....	126
control principle.....	40
current.....	43, 97, 125
data.....	123, 125
frequency.....	43
magnetisation at 0 speed.....	46
overload protection.....	12
power.....	125
set-up.....	9, 12
speed direction.....	55
speed high limit.....	55
speed low limit.....	55
status.....	96
thermal.....	97
thermal protection.....	32, 49
voltage.....	43, 97
Rotating.....	126
Motor pole.....	45
Motor thermal protection.....	12

N

Navigation key.....	8
---------------------	---

Network configuration.....	24
Network connection.....	16
No-flow detection.....	104
Nominal motor speed.....	44
NPN.....	58

O

Open loop.....	40
Open-loop application.....	9
Open-loop configuration.....	9
Operating data.....	93
Operating hour counter.....	93
Operating mode.....	34
Operating state at power-up.....	34
Operation key.....	9
Operation mode.....	90
Output filter.....	91
Overcurrent.....	118
Overheating.....	123
Overtemperature.....	123
Overtemperature fault counter.....	93
Overview, Modbus RTU.....	23
Overvoltage.....	93
Overvoltage control.....	50

P

Parameter lists.....	127
Parameter number (PNU).....	21
Parity/stop bit.....	72
Password.....	39
PELV.....	6
Phase loss.....	123
PI anti-windup.....	103
PI basic setting.....	102
PI controller.....	103
PI feed forward factor.....	103
PI integral time.....	103
PI normal/inverse control.....	102
PI proportional gain.....	103
PNP.....	58
PNU.....	21
Power card temperature.....	119
Power in hp.....	96
Power in kW.....	96
Power up counter.....	93
Preset ref bit 0.....	58

Preset ref bit 1.....	58	Set-up copy.....	39
Preset ref bit 2.....	58	Short circuit.....	118, 124
Preset reference.....	52	SL controller action.....	87
Preset relative reference.....	52	SL controller mode.....	82
PROFIBUS.....	5	SL controller timer.....	84
Programming		SLC setting.....	82
Indexed parameter.....	13	Sleep mode.....	107
Programming.....	8	Sleep speed [Hz].....	109
set-up.....	35	Slip compensation.....	47
with MCT 10 Set-up Software.....	8	Smart logic.....	82
Protocol.....	72	Smart logic controller event.....	87
Pulse input, 5-5*.....	65	Software version.....	5, 94
Q		Special functions.....	89
Quick menu.....	9, 12	Speed bypass.....	56
Quick stop ramp time.....	54	Speed down.....	58
R		Speed up.....	58
Ramp 1 ramp-up time.....	53	Square root.....	102
Ramp 2 ramp-down time.....	54	Start.....	58
Ramp 2 ramp-up time.....	54	Start delay.....	48
RCD.....	6	Start event.....	82
Read holding registers (03 hex).....	28	Start function.....	48
Recommended initialization.....	13	Start reversing.....	58
Ref. & Feedb.....	101	Stator leakage reactance.....	44
Reference 1 source.....	53	Stator resistance.....	44
Reference 2 source.....	53	Status menu.....	9
Reference 3 source.....	53	Status word.....	32, 96
Regional setting.....	34	Stop event.....	83
Relay.....	62	Switching frequency.....	89
Relay output [bin].....	99	Symbols.....	5
Reset.....	123, 124	T	
Reset kWh counter.....	93	Telegram length (LGE).....	19
Reset mode.....	90	Terminal 18 digital input.....	60
Reset SLC.....	83	Terminal 19 digital input.....	60
Restoring default setting.....	13	Terminal 27 digital input.....	61
Reversing.....	58	Terminal 29 digital input.....	61
RS485		Terminal 42	
RS485.....	15, 17	Terminal 42 analog output.....	69
installation and set-up.....	15	Terminal 42 digital output.....	69
Run permissive.....	58	Terminal 42 mode.....	69
Running hour counter.....	93	Terminal 42 output maximum scale.....	70
S		Terminal 42 output minimum scale.....	70
Semi-auto bypass set-up.....	57	Terminal 45	
Sensorless.....	102	Terminal 45 analog output.....	67
Serial communication.....	62	Terminal 45 digital output.....	68
Setpoint boost.....	109	Terminal 45 mode.....	67
		Terminal 45 output bus control.....	69
		Terminal 45 output max scale.....	68
		Terminal 45 output min scale.....	68

Terminal 53	
Terminal 53 filter time constant.....	67
Terminal 53 high current.....	66
Terminal 53 high voltage.....	66
Terminal 53 low current.....	66
Terminal 53 low voltage.....	66
Terminal 53 mode.....	67
Terminal 53 setting.....	98
Terminal 54	
Terminal 54 filter time constant.....	67
Terminal 54 high current.....	67
Terminal 54 high voltage.....	67
Terminal 54 low current.....	67
Terminal 54 low voltage.....	67
Terminal 54 mode.....	67
Terminal 54 setting.....	98
Terminals	
Input.....	123
Thermal load.....	46
Thermal overload.....	118
Thermistor.....	118
Thermistor source.....	49
Timer.....	84
Torque	
Constant torque.....	5
[%].....	97
limit.....	6
Variable torque.....	6
Trip.....	117
Trip lock.....	117
Trip reset.....	90
Troubleshooting.....	117, 123
U	
U/f characteristic.....	46
V	
Voltage imbalance.....	123
VVC+.....	6
W	
Warning.....	117
Warning current high.....	56
Warning current low.....	55
Warning word.....	99
Warning word 2.....	99
Wizard, closed-loop set-up.....	9
Wizard, open-loop application.....	9

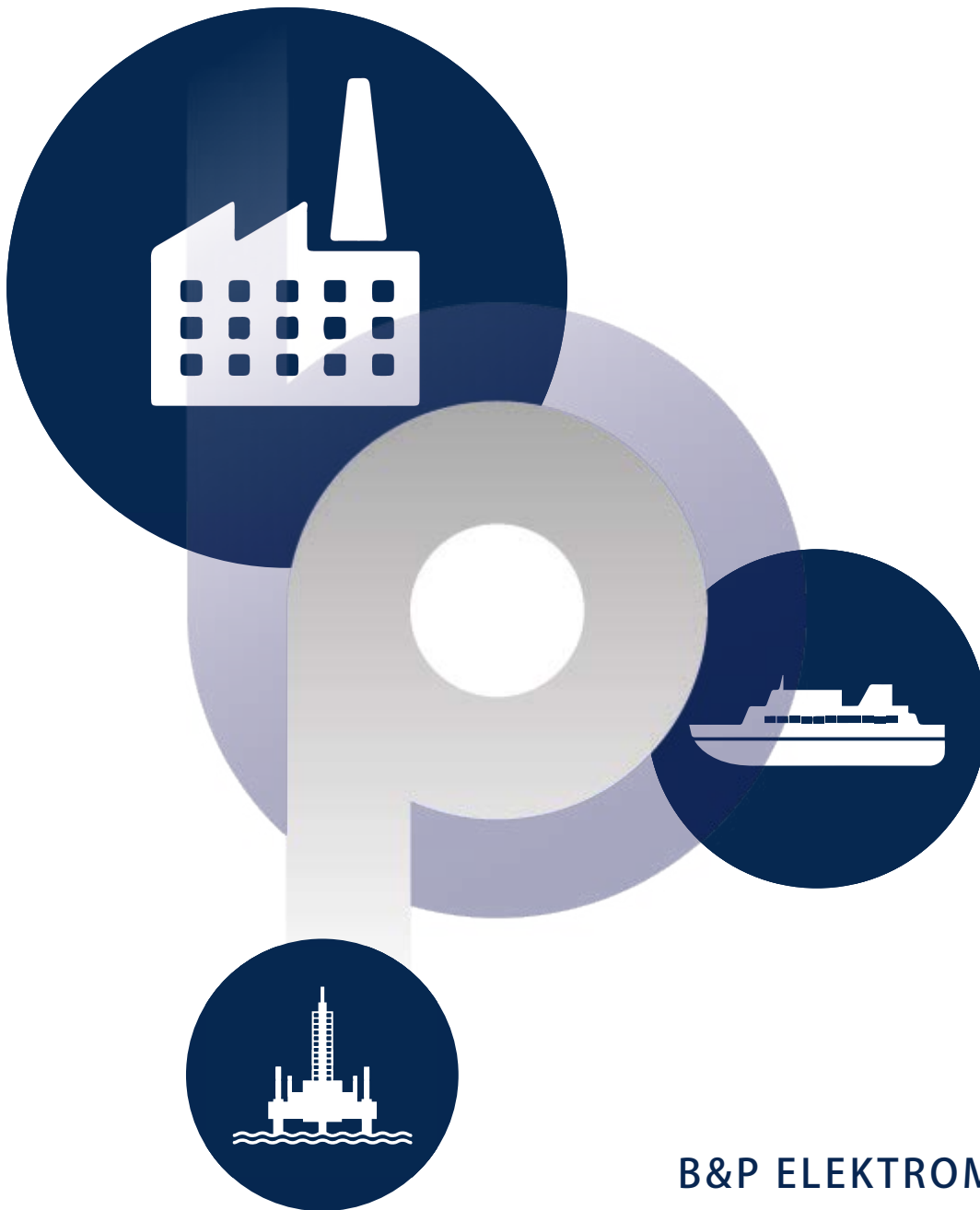

B&P ELEKTROMOTOREN BV

Ampèrestraat 8F
4004 KB Tiel

info@bnpelektromotoren.nl

+31 (0)344 616 267

BTW nr. NL819113918B01

KvK nr. 30237800

ING Bank NL60 INGB 0675 304 792



www.bnpelektromotoren.nl