

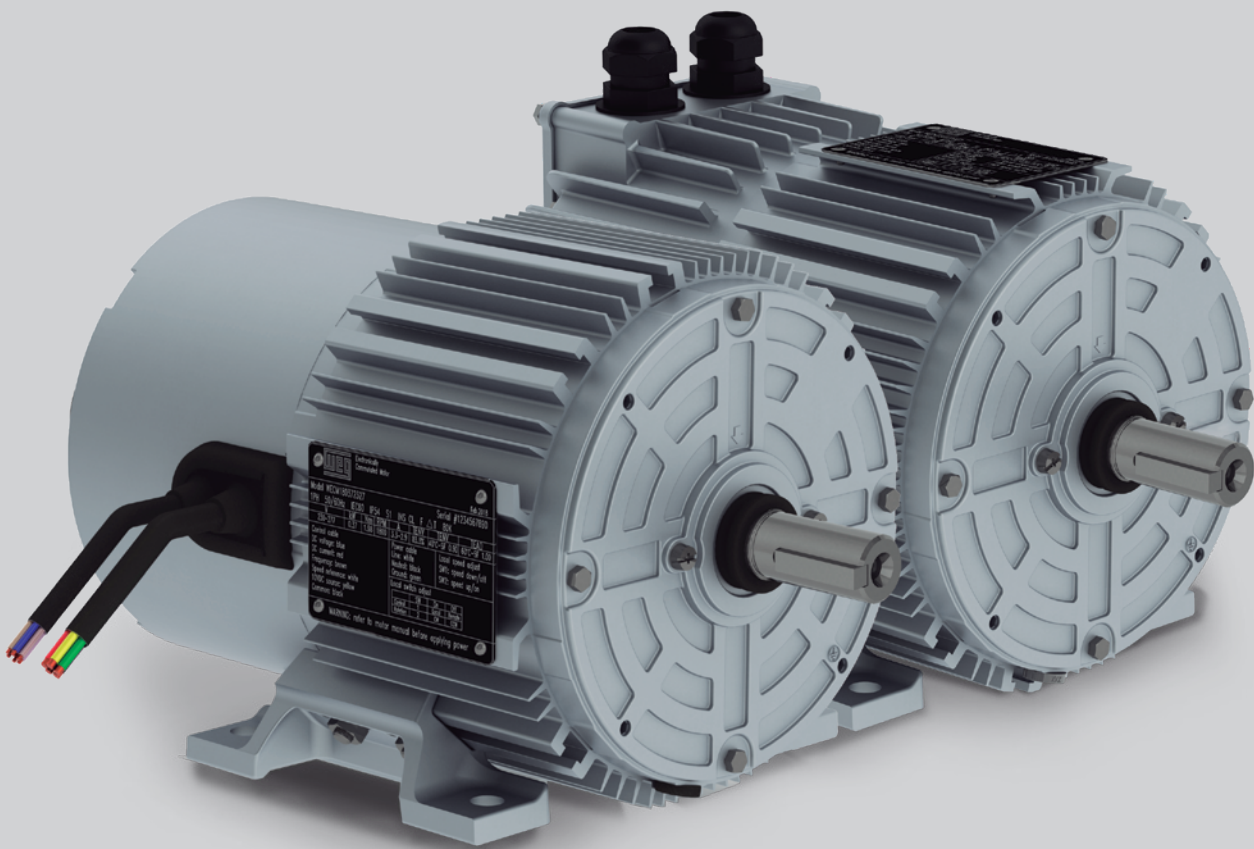

# B&P Elektromotoren

## WECM

Electronically Commutated Motor  
European Market



Motors | Automation | Energy | Transmission & Distribution | Coatings

# WECM

MOVING AIR WITH  
**EFFICIENCY**



## Electronically Commutated Motor with permanent magnets and built-in drive.

A comprehensive and versatile EC solution for a variety of air movement applications.

- Accurate speed control to guarantee fan performance and energy saving
- IEC footprint offering interchangeability with induction motors
- Market leading IE6 efficiency levels

Follow this movement towards higher efficiencies too.



Transforming energy into solutions.

## Standards

WECM motors comply with the latest versions of the following standards and regulations:

- EN 60034-1: Rotating electrical machines - Part 1: Rating and performance
- EN 60034-2-1: Rotating electrical machines - Part 2-1: Standard methods for determining losses and efficiency from tests (excluding machines for traction vehicles)
- EN 60034-5: Rotating electrical machines - Part 5: Degrees of protection provided by the integral design of rotating electrical machines (IP code) – Classification
- EN 60034-6: Rotating electrical machines - Part 6: Methods of cooling (IC code)
- EN 60034-7: Rotating electrical machines - Part 7: Classification of types of constructions, mounting arrangements and terminal box position (IM code)
- EN 60034-8: Rotating electrical machines - Part 8: Terminal markings and direction of rotation
- EN 60034-9: Rotating electrical machines - Part 9: Noise limits
- EN 60034-14: Rotating electrical machines - Part 14: Mechanical vibration of certain machines with shaft heights 56 mm and higher - measurement, evaluation and limits of vibration
- IEC TS 60034-2-3: Rotating electrical machines - Part 2-3: Specific test methods for determining losses and efficiency of converter-fed AC induction motors
- IEC TS 60034-30-2: Rotating electrical machines - Part 30-2: Efficiency classes of variable speed AC motors (IE-code)
- IEC 60072-1: Dimensions and Output Series for Rotating Electrical Machines Part 1: Frame Numbers 56 to 400 and Flange Numbers 55 to 1080
- EN 60204-1: Safety of machinery - electrical equipment of machines - Part 1: General requirements
- IEC 61800-3: Adjustable speed electrical power drive systems - Part 3: EMC requirements and specific test methods
- IEC 61000-3-2: Electromagnetic compatibility (EMC) - Part 3-2: Limits - Limits for harmonic current emissions
- IEC 61000-3-3: Electromagnetic compatibility (EMC) - Part 3-3: Limits - Limitation of voltage changes, voltage fluctuations and flicker in public low-voltage supply systems, for equipment with rated current  $\leq 16A$  per phase and not subject to conditional connection
- IEC 61800-5-1:2007: Adjustable speed electrical power drive systems - Part 5-1: Safety requirements - Electrical, thermal and energy (single-phase products)
- IEC 60335-1:2010 Household and similar electrical appliances - Safety - Part 1: General requirements (three-phase products)
- 2017/2102 (amending 2011/65/EU) - RoHS
- 2014/35/EU - The Low Voltage Directive (LVD)
- 2014/30/EU - Electromagnetic Compatibility (EMC) Directive

## Applications

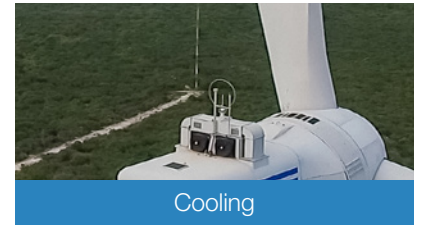

## Efficiency Comparison

WECM motors efficiency meet IE6 Efficiency Levels, as are shown in the graphs below:

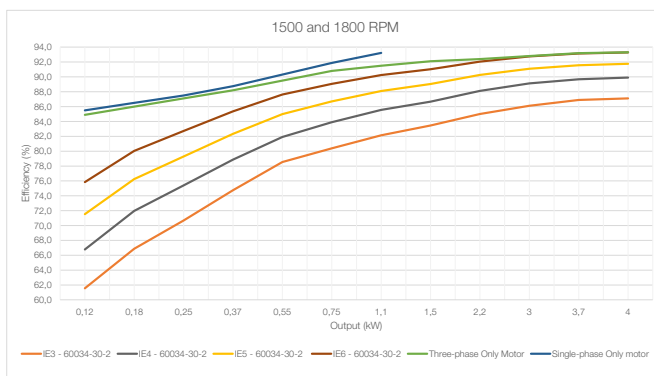

Figure 8. Efficiency comparison for 1500 and 1800 RPM electric motors

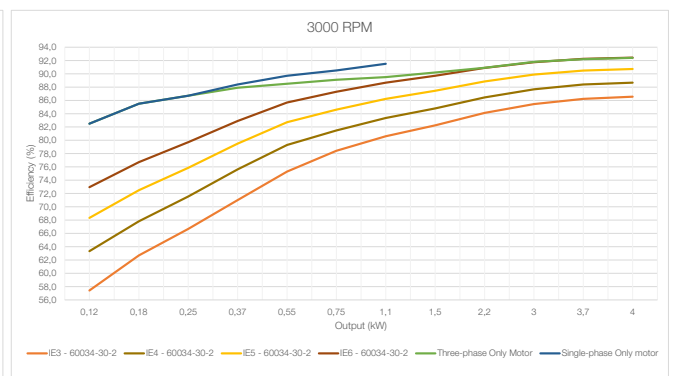

Figure 9. Efficiency comparison for 3000 RPM electric motors



# WECM

## WEG Electronically Commutated Motor

### Single-phase Motors

- Permanent Magnet, Electronically Commutated Motor
- Voltage: 220 to 277 VAC
- Frequency: 50/60 Hz input
- Output power: 0,12 to 1,1 kW at 1500, 1800 or 3000 rpm
- Aluminium frame / drive housing
- Degree of protection IP55
- Mounting: IEC80 B3L
- Ambient temperature  
-20 to 40 °C (TENV)<sup>1</sup>  
-20 to 60 °C (TEAO)<sup>2</sup>
- Motor efficiency – IE6<sup>3</sup>
- Vibration Grade A
- Direction of rotation CW/CCW (selectable)
- Continuous speed adjustment (200 to 1500/1800 rpm and 500 to 3000 rpm) by:
  - Tact buttons (local)
  - DC voltage (remote): 2 to 10 VDC
  - DC current (remote): 4 to 20 mA DC
  - PWM (remote): 10 to 95%
- Local controls optically isolated
- With drain plug and 'V' ring sealing
- Sealed for life bearings
- Drive-end bearing cap
- Power and control cables 500 mm long
- Electronic protection: overload, over temperature and locked-rotor.
- Fire mode (Override & Maximum speed mode)

### Three-phase Motors

- Permanent Magnet, Electronically Commutated Motor
- Voltage: 380-480 VAC
- Frequency: 50/60 Hz input
- Output power: 0,12 to 4 kW at 1500, 1800 or 3000 rpm
- Aluminium frame / drive housing
- Degree of protection IP55
- Mounting: IEC80 and IEC100, B3T
- Ambient temperature:  
-20 to 40 °C (TEAO)<sup>2</sup>  
-20 to 40 °C (TENV)<sup>1</sup> with de-rating  
-20 to 60 °C (TEAO) with de-rating
- Motor efficiency – IE6<sup>3</sup>
- Vibration Grade A
- Direction of rotation CW/CCW (selectable)
- Continuous speed adjustment (200 to 1500/1800 rpm and 500 to 3000 rpm) by:
  - Tact buttons (local)
  - DC voltage (remote): 2 to 10 VDC
  - DC current (remote): 4 to 20 mA DC
  - PWM (remote): 10 to 95%
  - Modbus Communication
- Alarm relay (NO & NC)
- Local controls optically isolated
- With drain plug and 'V' ring sealing
- Sealed for life bearings
- Drive-end bearing cap
- Connection box with push-in terminals
- Electronic protection: overload, over temperature and locked-rotor.
- Fire mode (Override & Maximum speed mode)

#### Notes:

1. Totally Enclosed, Non-ventilated. Refer to WEG for electrical data.

2. Totally Enclosed, Air Over rated. Minimum airflow over motor frame and drive cover 5m/s.

3. Efficiency code according IEC 60034-30-2 (testing according to IEC TS 60034-2-3 method 2-3-A).



## Optional & Special Features

### Single-phase Motors

- Passive PFC (Power Factor Correction)<sup>4</sup>
- IEC80: Pad mounting (4 x 90° or 3 x 120°), T-slot (4 x 90° or 3 x 120°), FF-165 and FC-120 flanges
- Slinger seal for vertical shaft-up mounting
- 115V input power supply (up to 0,55kW)
- Decentralised mounting (drive and motor separate)
- Customized cable lengths
- Customized shaft ends
- Double shaft ends (only with decentralised drive version)
- External controller with display to adjust maximum and instantaneous speed values
- TEBC blower cooling
- Modbus Communication

### Three-phase Motors

- IEC80: Pad mounting (4 x 90° or 3 x 120°), T-slot (4 x 90° or 3 x 120°), FF-165 and FC-120 flanges
- IEC100: Pad mounting (4 x 90°), T-slot (4 x 90°), FF-215 and FC-160 flanges
- Slinger seal for vertical shaft-up mounting
- Decentralised mounting (drive and motor separate)
- Power supply cable and control cable installation
- Customized shaft ends
- Double shaft ends (only with decentralised drive version)
- External controller with display to adjust maximum and instantaneous speed values

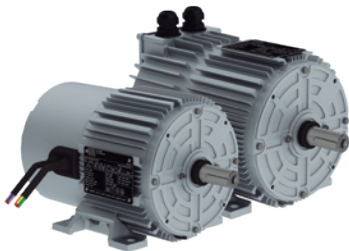

Figure 1. Foot mounting

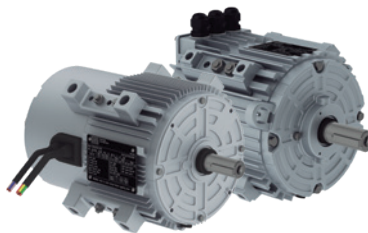

Figure 2. Pad mounting

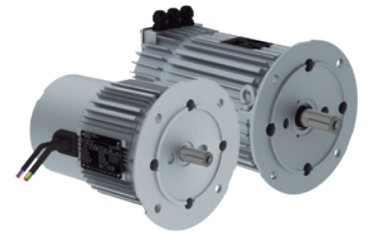

Figure 3. FF flange mounting

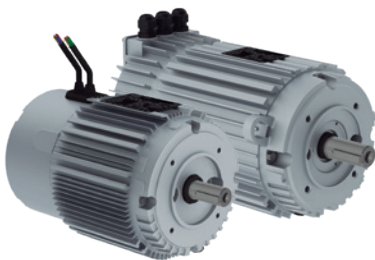

Figure 4. FC flange mounting



Figure 5. T-Slot



Figure 6. TEBC Motor

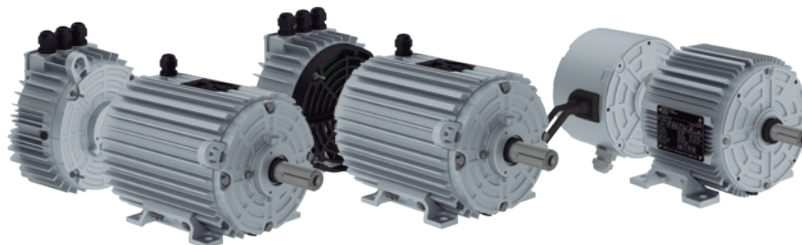

Figure 7. Decentralised

#### Notes:

4 - WECM single-phase motors may require the use of an external filter to comply with the harmonic current emissions requirements of EN 61000-3-2. Refer to WEG for further details.

## Electrical Data

### Single-phase WEG Electronically Commutated Motors

Cooling	220V / 1500 rpm					220V / 1800 rpm					220V / 3000 rpm				
	Model	kW	FLC In (A)	Torque (Nm)	Eff [%] <sup>1</sup>	Model	kW	FLC In (A)	Torque (Nm)	Eff [%] <sup>1</sup>	Model	kW	FLC In (A)	Torque (Nm)	Eff [%] <sup>1</sup>
TENV or TEAO	A2	0,12	1,4	0,76	83,0	A1	0,12	1,4	0,64	83,1	A1	0,12	1,4	0,38	77,5
	A3	0,18	1,8	1,15	83,4	A2	0,18	1,9	0,95	83,5		0,18	1,9	0,57	81,4
	A4	0,25	2,3	1,59	84,0	A3	0,25	2,3	1,33	84,1		0,25	2,4	0,80	82,3
	B	0,37	3,4	2,36	85,2	A4	0,37	3,5	1,96	85,3	A4	0,37	3,3	1,18	83,3
TEAO <sup>2</sup>	D	0,55	4,8	3,50	86,7	B	0,55	4,7	2,92	86,8	B	0,55	4,8	1,75	84,6
	E	0,75	5,8	4,77	88,2	D	0,75	5,7	3,98	88,2	C	0,75	5,9	2,39	86,3
		1,1	8,9	7,00	89,5	E	1,1	8,9	5,84	89,7		1,1	8,7	3,50	87,8

Note: 1) All data of the electrical table refers to the complete solution (Drive input current, Global Efficiency). Global solution efficiency:  $Eff = \eta_{MOTOR} \times \eta_{DRIVE}$   
 2) 0.55kW solution is limited to 0.50kW TENV; 0.75kW solution is limited to 0.65kW TENV.

### Three-phase WEG Electronically Commutated Motors

Cooling	380V / 1500 rpm					380V / 1800 rpm					380V / 3000 rpm				
	Model	kW	FLC In (A)	Torque (Nm)	Eff [%] <sup>1</sup>	Model	kW	FLC In (A)	Torque (Nm)	Eff [%] <sup>1</sup>	Model	kW	FLC In (A)	Torque (Nm)	Eff [%] <sup>1</sup>
TEAO	IEC80-A	0,12	0,35	0,76	83,0	IEC80-A	0,12	0,35	0,64	83,0	IEC80-A	0,12	0,37	0,38	77,5
		0,18	0,52	1,15	83,1		0,18	0,52	0,95	83,1		0,18	0,55	0,57	77,9
	IEC80-B	0,25	0,72	1,59	83,3	0,25	0,72	1,33	83,3	0,25		0,76	0,80	78,3	
	IEC80-C	0,37	1,06	2,36	83,6	IEC80-B	0,37	1,06	1,96	83,6	0,37	1,12	1,18	79,2	
	IEC80-D	0,55	1,56	3,50	84,1	IEC80-C	0,55	1,56	2,92	84,1	IEC80-B	0,55	1,64	1,75	80,3
		0,75	2,12	4,77	84,6	IEC80-D	0,75	2,12	3,98	84,6		0,75	2,20	2,39	81,5
	IEC80-E	1,1	3,07	7,00	85,6		1,1	3,07	5,84	85,6	IEC80-C	1,1	3,15	3,50	83,3
	IEC80-F	1,5	4,13	9,55	86,7	IEC80-E	1,5	4,13	7,96	86,7		1,5	4,22	4,77	84,8
	IEC100-C	2,2	5,96	14,01	88,1	IEC100-B	2,2	5,96	11,67	88,1	IEC100-A	2,2	6,08	7,00	86,4
	IEC100-D	3	8,04	19,10	89,1	IEC100-C	3	8,04	15,92	89,1		3	8,17	9,55	87,7
	IEC100-E	3,7	9,85	23,55	89,7	IEC100-D	3,7	9,85	19,63	89,7	IEC100-B	3,7	9,99	11,78	88,4
		4	10,62	25,46	89,9		4	10,62	21,22	89,9		4	10,77	12,73	88,7

Note: 1) All data of the electrical table refers to the complete solution (Drive input current, Global Efficiency). Global solution efficiency:  $Eff = \eta_{MOTOR} \times \eta_{DRIVE}$

# Mechanical Data

## Single-phase Motors External dimensions (in mm)

Model	Net Weight (kg) <sup>7</sup>	LC	LD <sup>6</sup>	L <sup>1,2,3</sup>	L <sup>4</sup>	Package dimensions ( L x W x H in mm)	
						1,2,3	4
A1	5,2	90	75	245	258	370 x 225 x 220 (40 motors / pallet <sup>5</sup> )	365 x 260 x 270 (36 motors / pallet <sup>5</sup> )
A2	5,8						
A3	6,4						
A4	7,7						
B	9,2	110	95	265	278		
C	9,6			285	298		
D	9,9	115	95	290	303		
E	11,7	135		310	323		

- 1) Foot mounting;
- 2) Pad mounting (4x90°);
- 3) Pad mounting (3x120°);
- 4) FF-165 flange mounting;
- 5) Pallet dimensions (LxWxH): 1200x800x1120 mm;
- 6) LD is the dimension of the drive in decentralised solution;
- 7) Approximate weight subject to change without notice.
- 8) Dimensions for TEBC and decentralised solutions can be provided upon request to WEG.

### B3L mounting

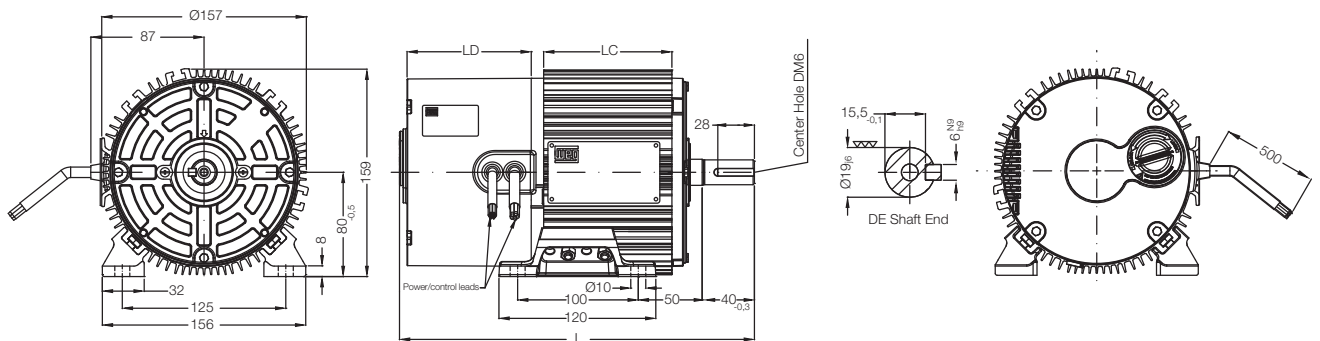

### B14L mounting (FC-120)

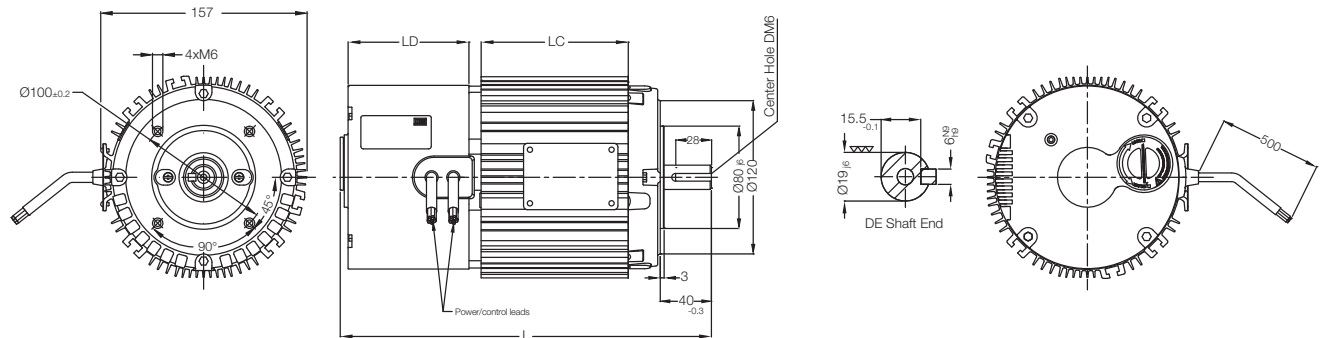



### B30L mounting (4 x 90°)

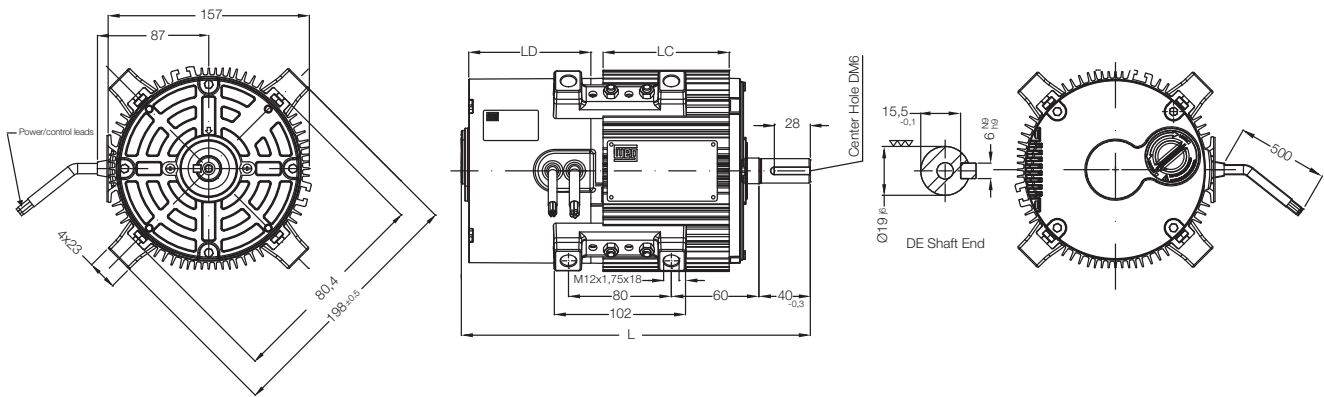

### B30L mounting (3 x 120°)

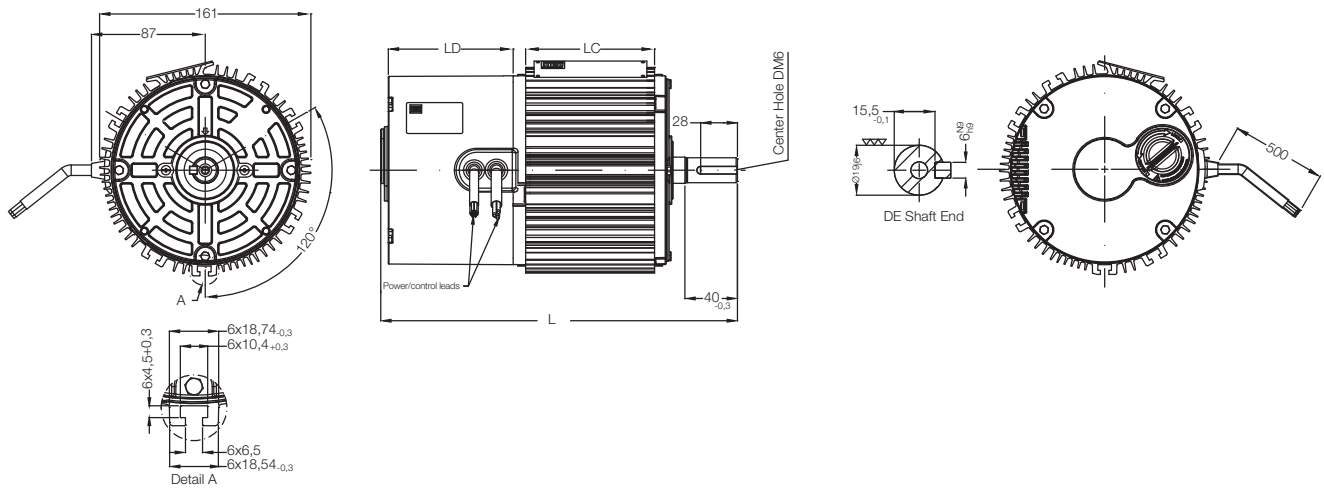

### B5L mounting (FF-165)

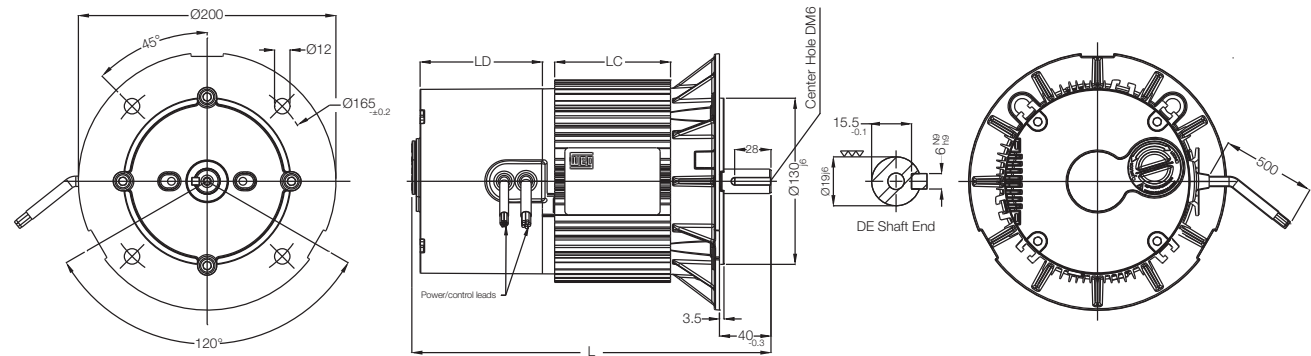

### Three-phase Motors External dimensions (in mm)

Model	Net Weight (kg) <sup>3</sup>	LC	LD <sup>2</sup>	L			Package dimensions (L x W x H in mm)		
				B3/B30	B14	B5	B3/B30	B14	B5
IEC80-A	5,8	90	89,1	256,1	269,1	370 x 225 x 220 (40 motors / pallet <sup>1</sup> )	365 x 260 x 270 (36 motors / pallet <sup>1</sup> )		
IEC80-B	6,4								
IEC80-C	8,1								
IEC80-D	8,5	100		266,1	279,1				
IEC80-E	9,9	115		281,1	294,1				
IEC80-F	11,7	135		301,1	314,1				
IEC100-A	17,5	105	95,3	315,8			435 x 270 x 270 (32 motors / pallet <sup>1</sup> )		
IEC100-B	19,5	120		330,8					
IEC100-C	21,0	135		345,8					
IEC100-D	22,5	150		360,8					
IEC100-E	26,0	175		385,8					

- 1) Pallet dimensions (L x W x H): 1200 x 800 x 1120 mm;
- 2) LD is the dimension of the drive in decentralised solution;
- 3) Approximate weight subject to change without notice.
- 4) Dimensions for decentralised solutions can be provided upon request to WEG.

### B3T Mounting

#### Frame 80

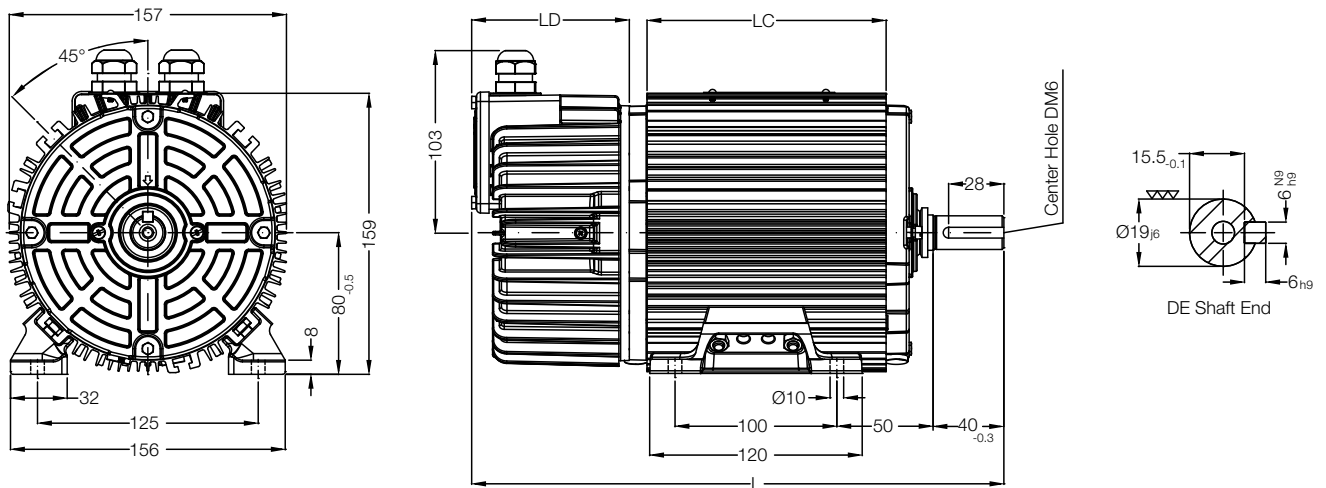

#### Frame 100

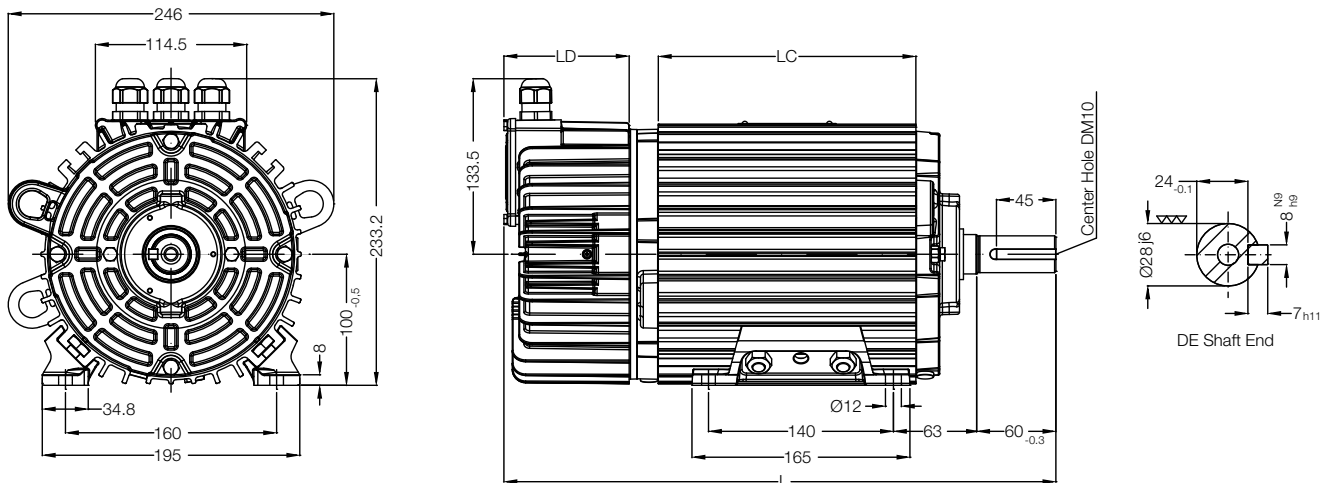

## B30T Mounting (4 x 90°)

### Frame 80

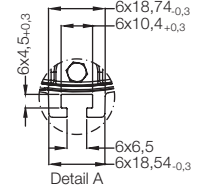
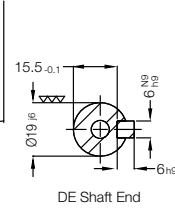
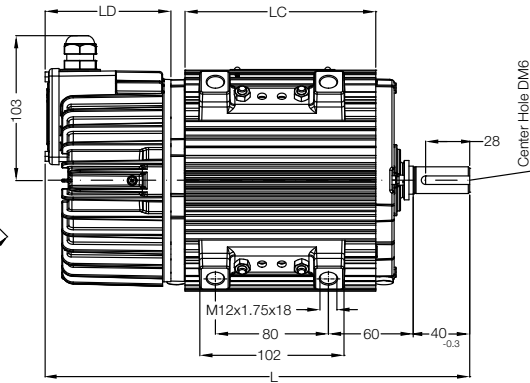
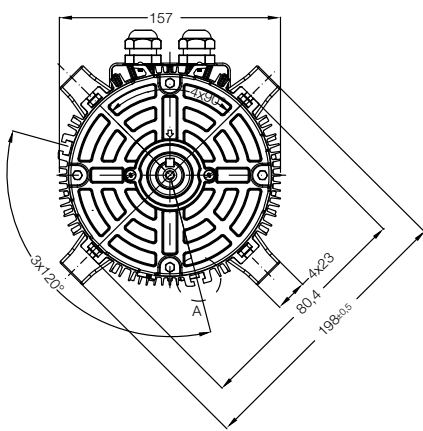

Frames 80 can be supplied with pad mounting or T-Slot (3x120°).

### Frame 100

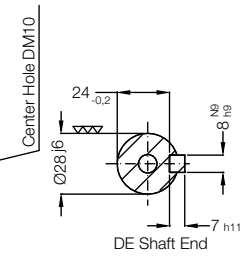
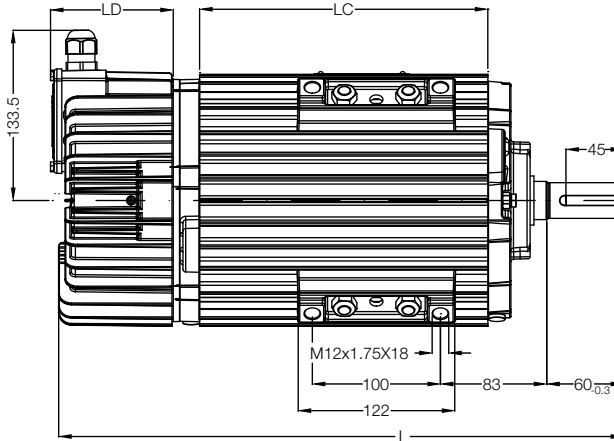
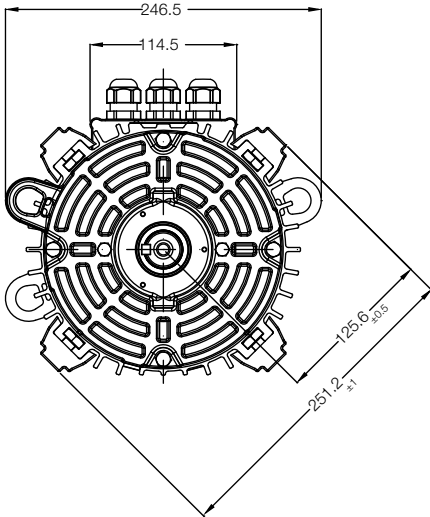

## B5T Mounting

### Frame 80 (FF-165)

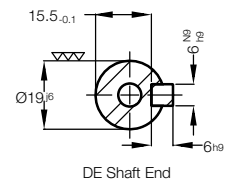
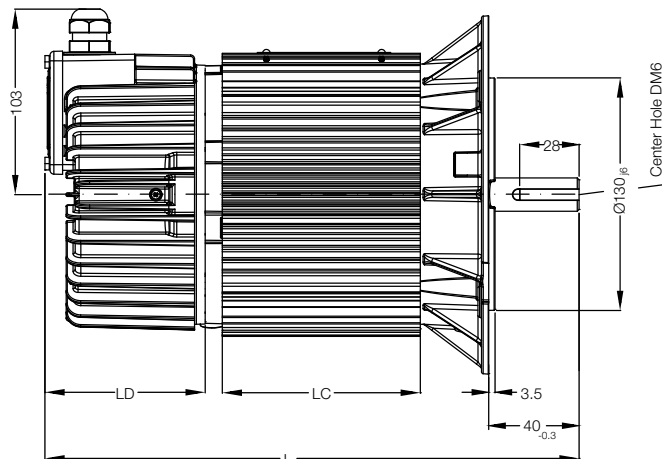
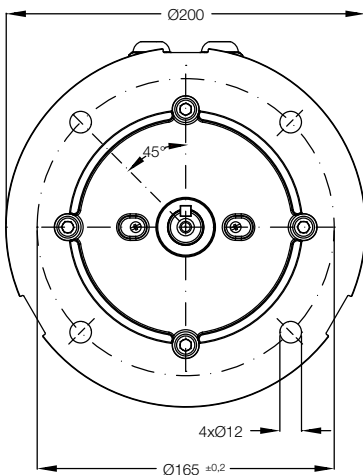



### B5T Mounting

#### Frame 100 (FF-215)

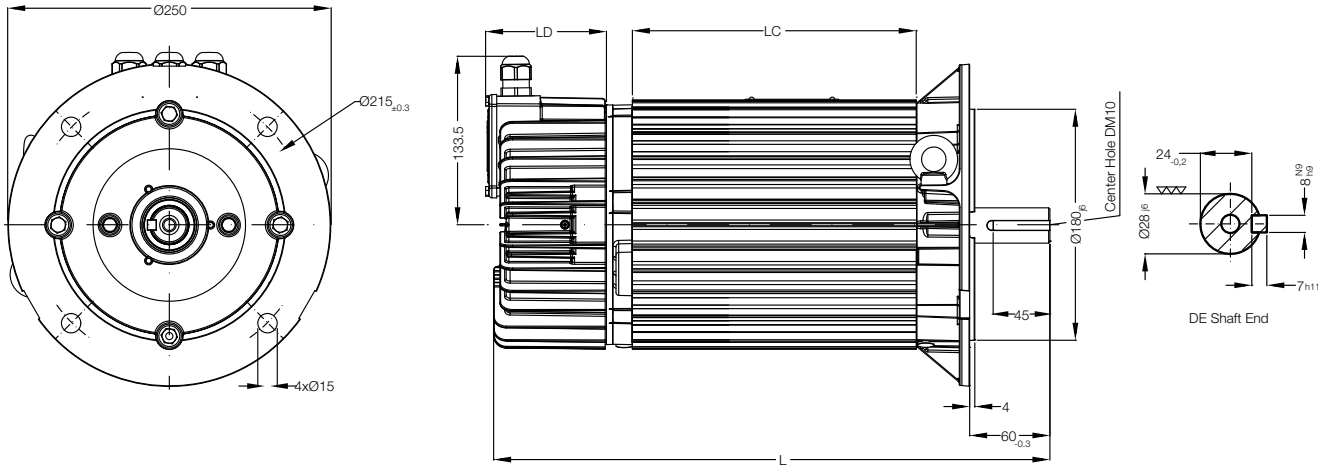

### B14T Mounting

#### Frame 80 (FC-120)

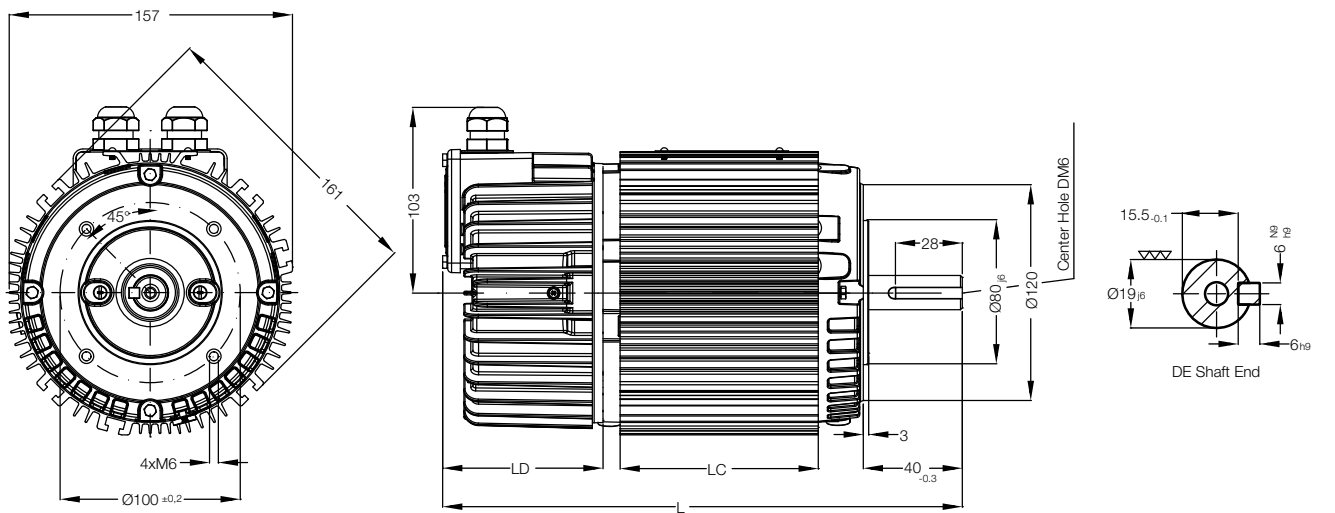

#### Frame 100 (FC-160)

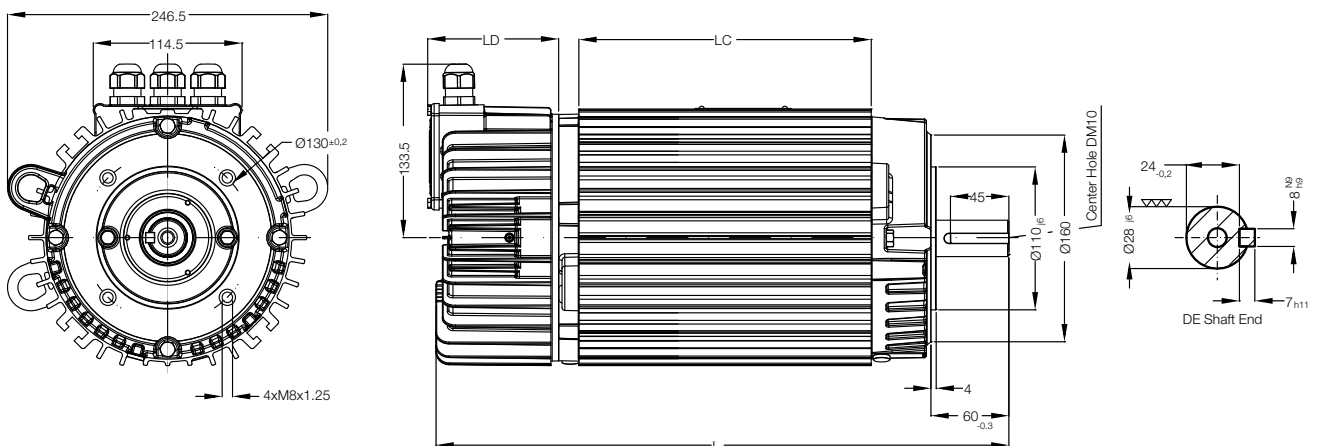

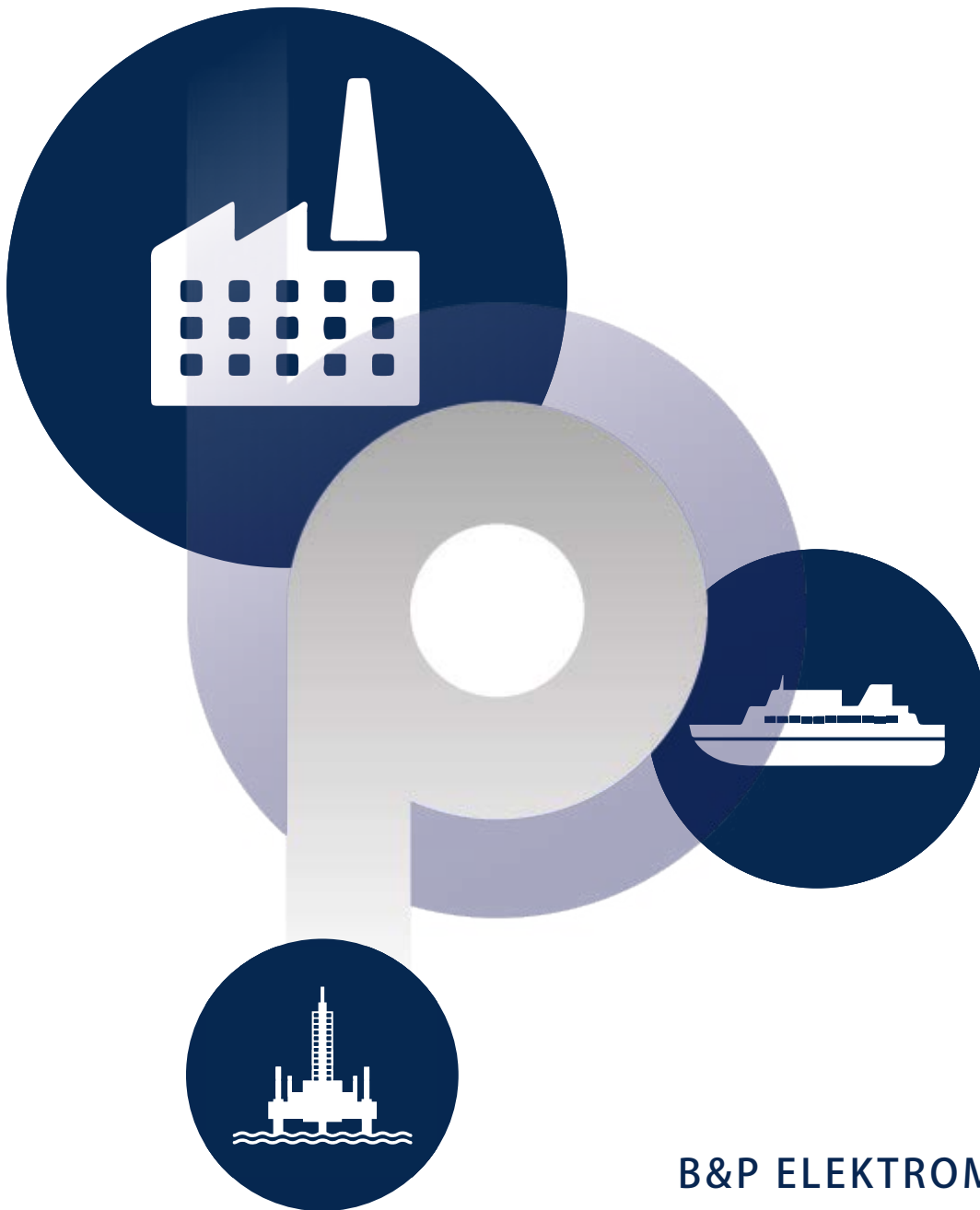

## B&P ELEKTROMOTOREN BV

Ampèrestraat 8F  
4004 KB Tiel

[info@bnpelektromotoren.nl](mailto:info@bnpelektromotoren.nl)

+31 (0)344 616 267

BTW nr. NL819113918B01

KvK nr. 30237800

ING Bank NL60 INGB 0675 304 792



[www.bnpelektromotoren.nl](http://www.bnpelektromotoren.nl)