



B&P Elektromotoren

VACON[®] 20 CP
AC DRIVES

**INSTALLATION, TECHNICAL AND MAINTENANCE
MANUAL**

INDEX

Document code (Original Instructions): DPD00489K

Order code: DOC-INS03976+DLUK

Rev. K

Revision release date: 29.8.18

1. Safety	6
1.1 Signs.....	6
1.2 Units.....	6
1.3 Danger.....	7
1.4 Hot surface warning.....	7
1.5 Warnings.....	8
1.6 Grounding and earth fault protection.....	9
1.7 Insulation system.....	10
1.8 Compatibility with RCDs.....	12
1.9 Cooling System.....	13
2. Receipt of delivery	14
2.1 Type designation code.....	15
2.2 Order codes.....	16
2.3 Unpacking and lifting the AC drive.....	16
2.4 Accessories.....	17
2.4.1 Disposal.....	17
3. Mounting	18
3.1 Dimensions.....	18
3.1.1 Enclosure MS2 three-phase version.....	18
3.1.2 Enclosure MS2 single-phase version.....	19
3.1.3 Enclosure MS3.....	20
3.2 Cooling.....	21
3.3 Environment temperature.....	21
3.4 Heatsink assembly instructions.....	21
3.5 Installation spacing.....	24
3.6 Power loss thermal characteristics.....	25
3.7 Dimensioning an external heatsink.....	26
4. Power cabling	29
4.1 Circuit breaker.....	31
4.2 UL standards on cabling.....	31
4.3 Description of the terminals.....	32
4.3.1 MS2 three-phase version power connections.....	32
4.3.2 MS2 single-phase version power connections.....	33
4.3.3 MS3 power connections.....	34
4.4 Cable dimensioning and selection.....	35
4.4.1 Cable and fuse sizes, enclosures MS2 to MS3.....	35
4.4.2 Cable and fuse sizes, enclosures MS2 to MS3, North America.....	36
4.5 Brake resistor cables.....	37
4.6 Control cables.....	37
4.7 Cable installation.....	37
5. Control unit	39
5.1 Control unit cabling.....	42
5.1.1 Control cable sizing.....	42
5.1.2 Standard I/O terminals.....	43
5.1.3 Relay terminals.....	44
5.1.4 Safe Torque off (STO) terminals.....	44
5.1.5 Description of additional echo connectors.....	45
5.1.6 Led handling.....	49

5.1.7	Selection of terminal functions with dip switches	50
5.2	Fieldbus connection	51
5.2.1	Modbus RTU protocol	52
5.2.2	Preparation for use through RS485.....	53
6.	Commissioning	54
6.1	Commissioning of the drive	55
6.2	Changing EMC protection class.....	56
6.2.1	Changing EMC protection class - MS2 three-phase version	56
6.2.2	Changing EMC protection class - MS2 single-phase version	58
6.2.3	Changing EMC protection class - MS3	59
6.3	Running the motor	60
6.3.1	Cable and motor insulation checks	60
6.4	Maintenance	61
6.4.1	Recharging capacitors in stored units.....	61
7.	Technical data.....	62
7.1	AC drive power ratings.....	62
7.1.1	Mains voltage 3AC 208-240V.....	62
7.1.2	Mains voltage 1AC 208-240V.....	62
7.1.3	Mains voltage 3AC 380-480V.....	63
7.1.4	Definitions of overloadability	63
7.2	Brake resistors	64
7.2.1	Internal brake resistor.....	64
7.2.2	External brake resistor	64
7.3	VACON® 20 CP - technical data	65
7.3.1	Technical information on control connections.....	68
8.	Options.....	70
8.1	VACON® keypad with seven-segment display.....	70
8.2	Text keypad	71
8.3	Menu structure	72
8.4	Using the keypad.....	73
8.4.1	Main menu.....	73
8.4.2	Resetting fault.....	74
8.4.3	Local/Remote control button.....	74
8.4.4	Reference menu.....	75
8.4.5	Monitoring menu	76
8.4.6	Parameter menu	77
8.4.7	System/Fault menu.....	78
8.5	Fault tracing	80
8.6	Option boards	84
8.6.1	Option board installation	85
9.	Safe Torque Off	88
9.1	General description.....	88
9.2	Warnings	89
9.3	Standards	90
9.4	The principle of STO	91
9.4.1	Technical details	92
9.5	Connections.....	93
9.5.1	Safety Capability Cat. 4 / PL e / SIL 3	94
9.5.2	Safety Capability Cat. 3 / PL e / SIL 3	96
9.5.3	Safety Capability Cat. 2 / PL d / SIL 2	96
9.5.4	Safety Capability Cat. 1 / PL c / SIL 1.....	97
9.6	Commissioning	98
9.6.1	General wiring instructions	98
9.6.2	Checklist for commissioning	98

9.7	Parameters and fault tracing	99
9.8	Maintenance and diagnostics	99

1. SAFETY

This manual contains clearly marked warning information which is intended for your personal safety and to avoid any unintentional damage to the product or connected appliances.

Please read the warning information carefully.

VACON® CP is a Cold Plate drive designed to control asynchronous AC motors and permanent magnet motors. The product is intended to be installed in a restricted access location and for a general purpose use.

Only VACON® authorized, trained and qualified personnel are allowed to install, operate and maintain the drive.

1.1 SIGNS

The cautions and warnings are marked as follows:



	= DANGEROUS VOLTAGE!
	= HOT SURFACE!
	= WARNING or CAUTION

Table 1. Warning signs.

1.2 UNITS

The dimensions used in this manual conform to International Metric System units, otherwise known as SI (Système International d’Unités) units. For the purpose of the equipment’s UL certification, some of these dimensions are accompanied by their imperial equivalents.

length	1 mm	0.0394 inch	25.4	inch
Weight	1 kg	2.205 lb	0.4536	pound
Speed	1 min ⁻¹	1 rpm	1	revolution per minute
Temperature	1 °C (T1)	33.8 °F (T2)	T2 = T1 x 9/5 + 32	Fahrenheit
Torque	1 Nm	8.851 lbf in	0.113	pound-force inches
Power	1 kW	1.341 HP	0.7457	horsepower

Table 2. Unit conversion table.

1.3 DANGER



The **components of the power unit of VACON[®] 20 CP drives are live** when the drive is connected to mains potential. Coming into contact with this voltage is **extremely dangerous** and may cause death or severe injury.



The **motor terminals (U, V, W) are live** when VACON[®] 20 CP Drive is connected to the mains, even if the motor is not running.



After disconnecting the AC drive from the mains, **wait** until the indicators on the keypad go out (if no keypad is attached, see the indicators on the cover). Wait an additional 30 seconds before starting any work on the connections of VACON[®] 20 Cold Plate Drive. After expiration of this time, use measuring equipment to absolutely ensure that no voltage is present. **Always ensure absence of voltage before starting any electrical work!**



The control I/O-terminals are isolated from the mains potential. However, the **relay outputs and other I/O-terminals may have a dangerous control voltage** present even when VACON[®] 20 CP Drive is disconnected from the mains.



During a coast stop (see the Application Manual), the motor is still generating voltage to the drive. Therefore, do not touch the components of the AC drive before the motor has completely stopped. Wait until the indicators on the keypad go out (if no keypad is attached, see the indicators on the cover). Wait an additional 30 seconds before starting any work on the drive.

1.4 HOT SURFACE WARNING



The metal parts of the enclosure may exceed 70°C (158 °F). **Do not touch them due a high risk of being burn.**

1.5 WARNINGS



VACON® 20 CP AC drive is meant for **fixed installations only**.



Only DVC A circuits (Decisive Voltage Class A, according to IEC 61800-5-1) are allowed to be connected to the control unit. This advice aims to protect both the drive and the client-application. VACON® is not responsible for direct or consequential damages resulting from unsafe connections of external circuits to the drive. See 1.7 for more details.



Do not perform any measurements when the AC drive is connected to the mains.



The **touch current** of VACON® 20 CP drives exceeds 3.5mA AC. According to standard EN61800-5-1, **a reinforced protective ground connection** must be ensured. See 1.6.



If the AC drive is used as a part of a machine, the **machine manufacturer is responsible** for providing the machine with a **supply disconnecting device** (EN 60204-1). See 4.1



Only **spare parts** supplied by VACON® can be used.



At power-up, power brake or fault reset, **the motor will start immediately** if the start signal is active, unless the pulse control for Start/Stop logic has been selected. Furthermore, the I/O functionalities (including start inputs) may change if parameters, applications or software are changed. Disconnect, therefore, the motor if an unexpected start can cause danger. This is valid only if STO inputs are energized. For prevention on unexpected restart, use appropriate safety relay connected to the STO inputs.



The **motor starts automatically** after automatic fault reset if the autoreset function is activated. See the Application Manual for more detailed information. This is valid only if STO inputs are energized. For prevention on unexpected restart, use appropriate safety relay connected to the STO inputs.



Before performing any measurement on the motor or the motor cable, disconnect the motor cable from the AC drive.



Do not perform any voltage withstand test on any part of VACON® 20 CP. The tests shall be performed according to a specific procedure. Ignoring this procedure may damage the product.



Do not touch the components on the circuit boards. Static voltage discharge may damage the components.



Check that the **EMC level** of the AC drive corresponds to the requirements of your supply network.



In a domestic environment, this product may cause radio interference, in which case supplementary mitigation measures may be required.



Do not use the internal Brake Resistor in installations above 2000 m altitude.

1.6 GROUNDING AND EARTH FAULT PROTECTION



CAUTION!

The VACON[®] 20 CP AC drive must always be earthed with a grounding conductor connected to the grounding terminal marked with .

Since the touch current exceeds 3.5 mA AC (for the three-phase version), according to EN61800-5-1, the drive shall have a fixed connection and provision of an additional terminal for a second protective grounding conductor of the same cross-sectional area as the original protective grounding conductor.

Three screws (for the three-phase version) are provided for: the ORIGINAL protective grounding conductor, the SECOND protective conductor and the MOTOR protective conductor (the customer can choose the screw for each one). See Figure 1 for the location of the three screws in the two possible options available.

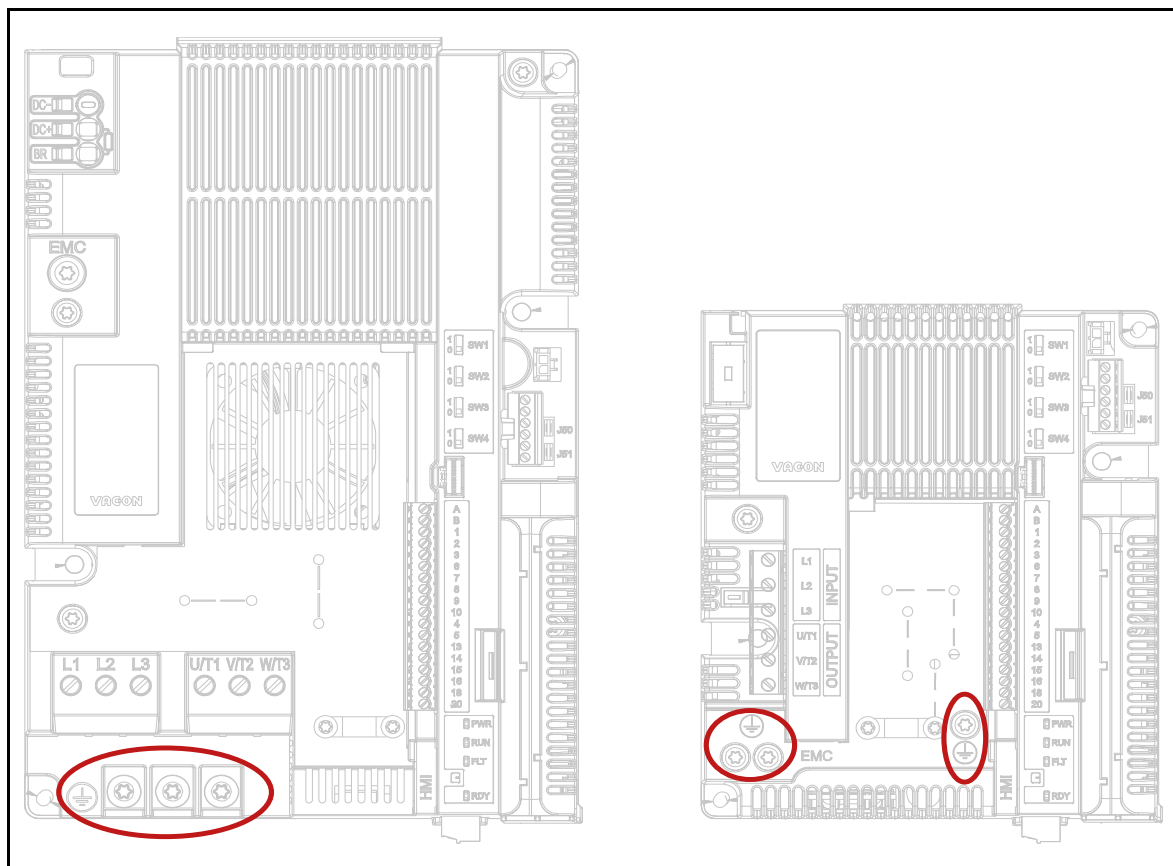

Figure 1. Protective grounding connections MS2 and MS3, three-phase version.

In VACON[®] 20 CP, the phase conductor and the corresponding protective grounding conductor can be of the same cross-sectional area, provided they are made of the same metal (because the cross-sectional area of the phase conductor is less than 16 mm²).

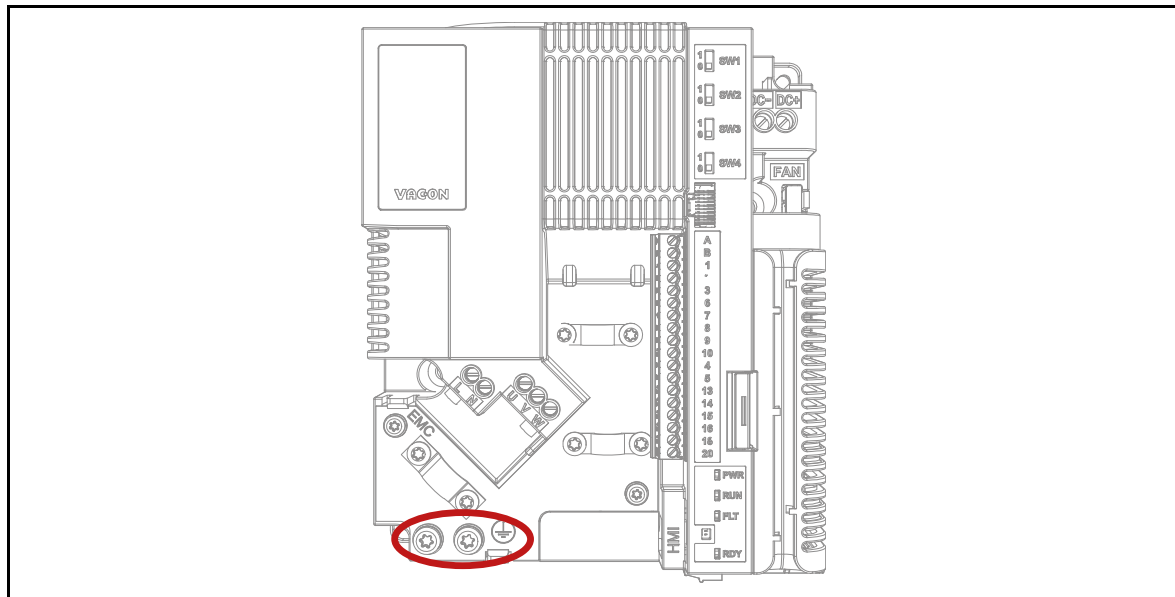

Figure 2. Protective grounding connections MS2, single-phase version.

The cross-sectional area of every protective grounding conductor which does not form a part of the supply cable or cable enclosure shall, in any case, be not less than:

- 2.5 mm² if mechanical protection is provided or
- 4 mm² if mechanical protection is not provided. For cord-connected equipment, provisions shall be made so that the protective grounding conductor in the cord shall, in the case of failure of the strain-relief mechanism, be the last conductor to be interrupted.

However, always follow the local regulations for the minimum size of the protective grounding conductor.

NOTE: Due to the high capacitive currents present in the AC drive, fault current protective switches may not function properly.

1.7 INSULATION SYSTEM



Please, consider carefully the insulation system depicted in Figure 2, before connecting any circuit to the unit.



The control unit of VACON[®] 20 CP fulfils the insulation requirements of the standard IEC 61800-5-1 regarding DVC A circuits and also the strongest insulation requirements of IEC 60950-1 regarding SELV circuits.

A distinction has to be made for the following three groups of terminals, according to the insulation system of VACON[®] 20 CP:

- Mains and motor connections (L1, L2, L3, U, V, W) or (L, N, U, V, W)
- Relays (R01, R02)^(**)
- Control terminals (I/Os, RS485, ST0)

The Control terminals (I/Os, RS485, STO) are isolated from the Mains (the insulation is reinforced, according to IEC 61800-5-1) and **the GND terminals are referred to PE.**

This is important when you need to connect other circuits to the drive and test the complete assembly. Should you have any doubts or questions, please contact your local distributor.

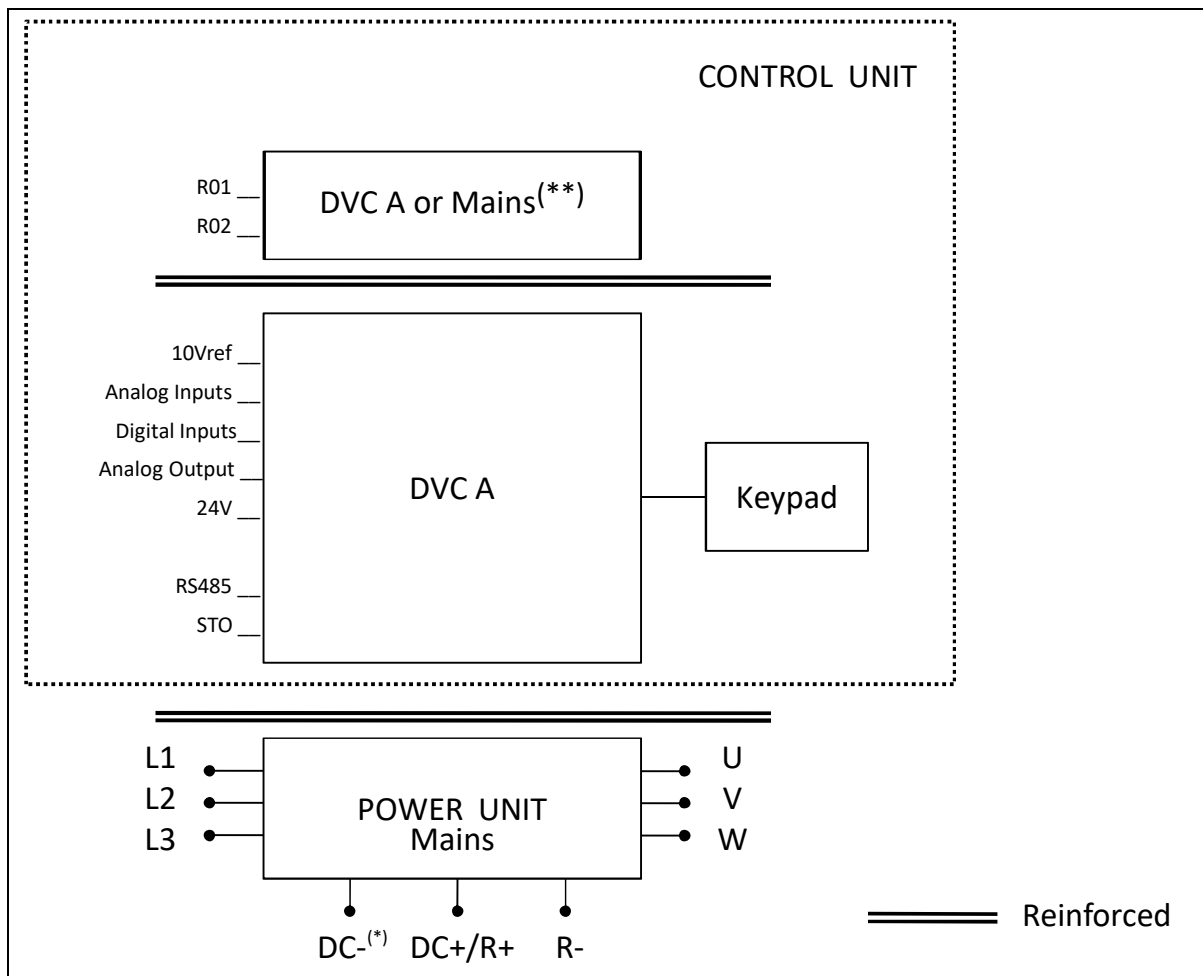

Figure 3. Insulation system (three-phase version).

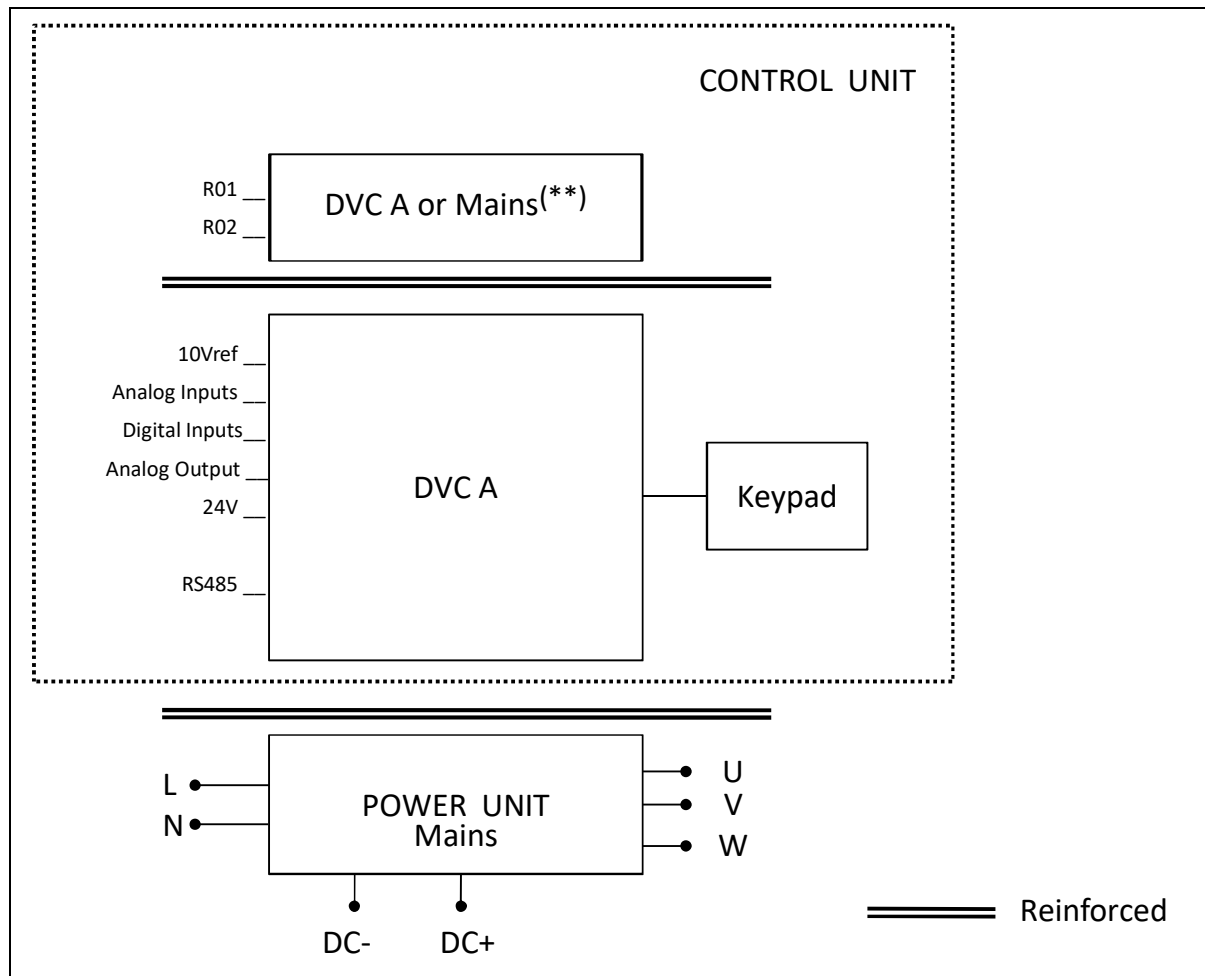

Figure 4. Insulation system (single-phase version).



(*) Only for MS3.



(**) The relays may be used also with DVC A circuits. This is possible only if both relays are used for DVC A circuitry: **to mix Mains and DVC A is not allowed.**

1.8 COMPATIBILITY WITH RCDs



This product can cause a d.c. current in the protective grounding conductor. Where a **residual current-operated protective (RCD) or monitoring (RCM) device** is used for protection in case of direct or indirect contact, only an RCD or RCM of **Type B** is allowed on the supply side of this product.

1.9 COOLING SYSTEM

VACON[®] 20 CP is available as a cold-plate solution. Customers have to enclose it in their own housing and provide a suitable heatsink. However under maximum operating conditions the unit should not exceed the following temperatures:

- Temperature around the polymeric enclosure (of VACON[®] 20 CP): max. 70 °C (158 °F)
- Temperature at the cooling-plate (of VACON[®] 20 CP): max. 85 °C (185 °F)

Please, contact your local distributor if you need further details or support to dimension the cooling system in your final application.

NOTE: Up to 1.5 kW (Voltage range 380-480V) and 0.75 kW (Voltage range 208-240V) the drive is not equipped with main cooling fan.

NOTE! You can download the English and French product manuals with applicable safety, warning and caution information from <https://www.danfoss.com/en/service-and-support/>.

REMARQUE Vous pouvez télécharger les versions anglaise et française des manuels produit contenant l'ensemble des informations de sécurité, avertissements et mises en garde applicables sur le site <https://www.danfoss.com/en/service-and-support/>.

2. RECEIPT OF DELIVERY

Check the correctness of delivery by comparing your order data to the drive information found on the package label. If the delivery does not correspond to your order, contact your supplier immediately. See paragraph 2.4.

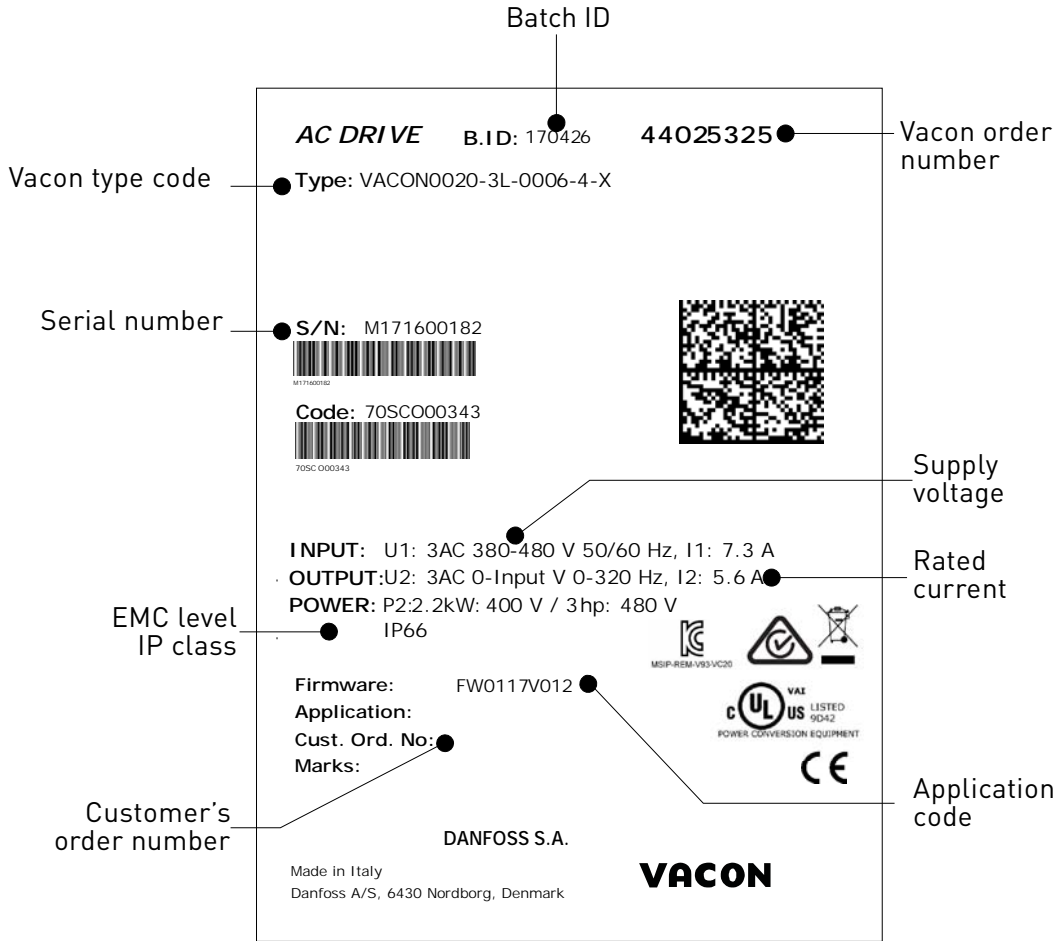

Figure 5. VACON® package label.

2.1 TYPE DESIGNATION CODE

VACON® type designation code is formed of a nine-segment code and optional +codes. Each segment of the type designation code uniquely corresponds to the product and options you have ordered. The format of the code is as follows:

VACON0020-3L-0009-4-CP +xxxx +yyyy

VACON

This segment is common for all products.

0020

Product range:

0020 = Vacon 20

3L

Input/Function:

3L = Three-phase input

1L = Single-phase input

0009

Drive rating in ampere; e.g. 0009 = 9 A

See Table , Table and Table 41 for all the drive ratings

4

Supply voltage:

2 = 208-240 V

4 = 380-480 V

CP

- Cold Plate

+xxxx +yyyy

Additional codes.

Examples of additional codes:

+DBIR

Dynamic Brake Internal Resistance (optional)

2.2 ORDER CODES

The order codes for VACON[®] 20 Cold Plate drive family are shown in the following table:

Enclosure size	Order code	Description
Supply voltage 3AC 208-240V		
MS2	VACON0020-3L-0004-2-CP	0.75 kW - 1.0 HP drive
	VACON0020-3L-0005-2-CP	1.1 kW - 1.5 HP drive
	VACON0020-3L-0007-2-CP	1.5 kW - 2.0 HP drive
MS3	VACON0020-3L-0011-2-CP	2.2 kW - 3.0 HP drive
	VACON0020-3L-0012-2-CP	3.0 kW - 4.0 HP drive
	VACON0020-3L-0017-2-CP	4.0 kW - 5.0 HP drive
Supply voltage 1AC 208-240V		
MS2	VACON0020-1L-0004-2-CP	0.75 kW - 1.0 HP drive
	VACON0020-1L-0005-2-CP	1.1 kW - 1.5 HP drive
	VACON0020-1L-0007-2-CP	1.5 kW - 2.0 HP drive
Supply voltage 3AC 380-480V		
MS2	VACON0020-3L-0003-4-CP	0.75 kW - 1.0 HP drive
	VACON0020-3L-0004-4-CP	1.1 kW - 1.5 HP drive
	VACON0020-3L-0005-4-CP	1.5 kW - 2.0 HP drive
	VACON0020-3L-0006-4-CP	2.2 kW - 3.0 HP drive
	VACON0020-3L-0008-4-CP	3.0 kW - 4.0 HP drive
MS3	VACON0020-3L-0009-4-CP	4.0 kW - 5.0 HP drive
	VACON0020-3L-0012-4-CP	5.5 kW - 7.5 HP drive
	VACON0020-3L-0016-4-CP	7.5 kW - 10.0 HP drive

Table 3. Order codes of VACON[®] 20 Cold Plate.

For all technical details, see chapter 7.

2.3 UNPACKING AND LIFTING THE AC DRIVE

The weights of the AC drives vary according to enclosure size. Note the weights of each individual enclosure size in Table 4 below.

Enclosure	Weight [kg]	Weight [lb]
MS2	2	4.4
MS3	3	6.6

Table 4. Enclosure weights.

VACON[®] 20 Cold Plate drives have undergone scrupulous tests and quality checks at the factory before they are delivered to the customer. However, after unpacking the product, check that no signs of transport damage are to be found on the product and that the delivery is complete.

Should the drive have been damaged during shipping, please contact the cargo insurance company or the carrier in the first instance.

2.4 ACCESSORIES

After lifting the AC drive out, check that the delivery is complete and the following accessories are included in the plastic bag:

Item	Quantity	Purpose
STO terminal connector *	1	Six pin black connector (see Figure 6) to use STO function
M3.5 x 8 TapTite screw	4	Screws for control cable clamps
M1-3 Cable clamp	2	Clamping control cables

*. Included only in the MS2 three-phase version and MS3.

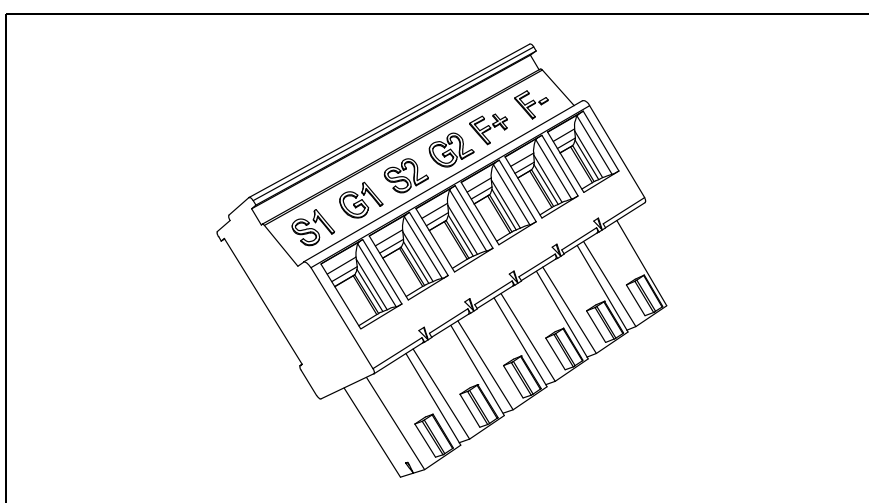

Figure 6. STO connector.

2.4.1 DISPOSAL

	<p>When the device reaches the end of its operating life do not dispose of it as a part of standard household garbage. Main components of the product can be recycled, but some need to be fragmented to separate different types of materials and components that need to be treated as special waste from electrical and electronic components. To ensure environmentally sound and safe recycling treatment, the product can be taken to appropriate recycling center or returned to the manufacturer.</p> <p>Observe local and other applicable laws as they may mandate special treatment for specific components or special treatment may be ecologically sensible.</p>
--	---

3. MOUNTING

The AC drive **can be mounted** on the wall or on the back plane of a cubicle. Ensure that the mounting plane is relatively even. Both enclosure sizes can be mounted in any position (IP20 rating is preserved only if mounted as in the following pictures). The drive shall be fixed with two screws (or bolts, depending on the unit size).

3.1 DIMENSIONS

3.1.1 ENCLOSURE MS2 THREE-PHASE VERSION

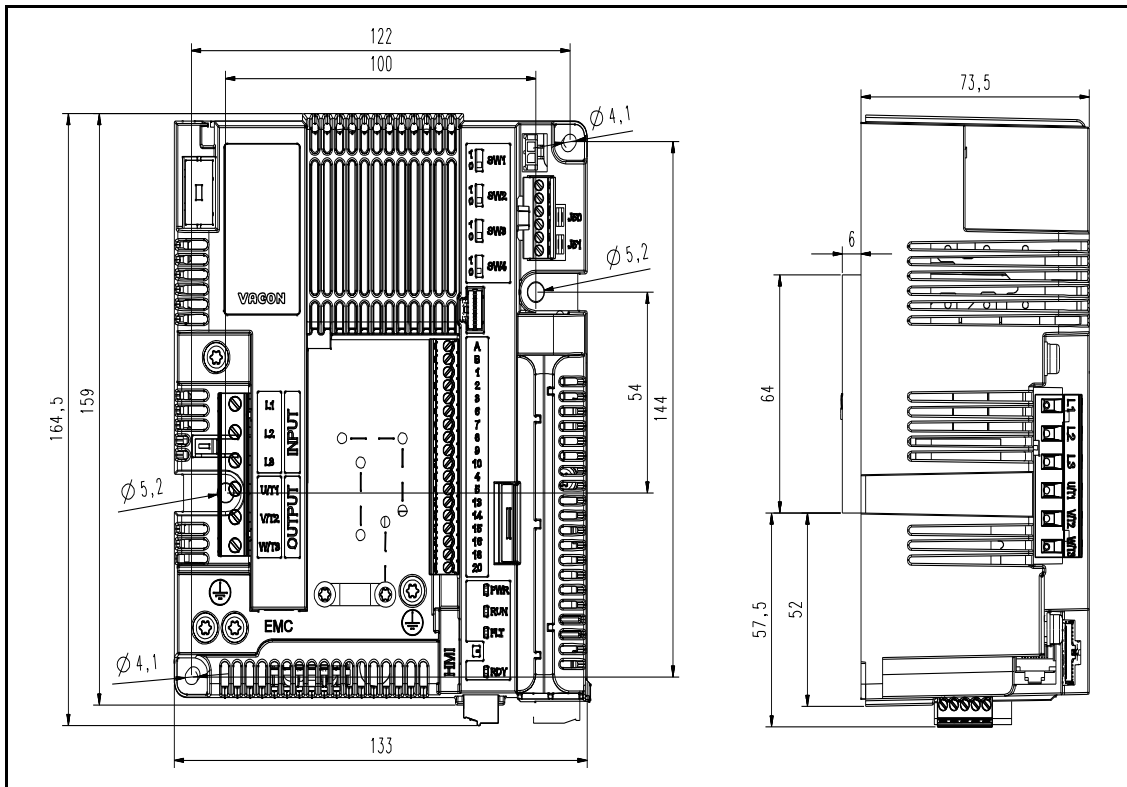

Figure 7. VACON® 20 Cold Plate, MS2 three-phase version.

Table 5.

Enclosure	Dimensions W x H x D	
	[mm]	[in]
MS2	133.0 x 164.5 x 73.5	5.24 x 6.48 x 2.89
MS2 with plate	133.0 x 164.5 x 79.5	5.24 x 6.48 x 3.13

3.1.2 ENCLOSURE MS2 SINGLE-PHASE VERSION

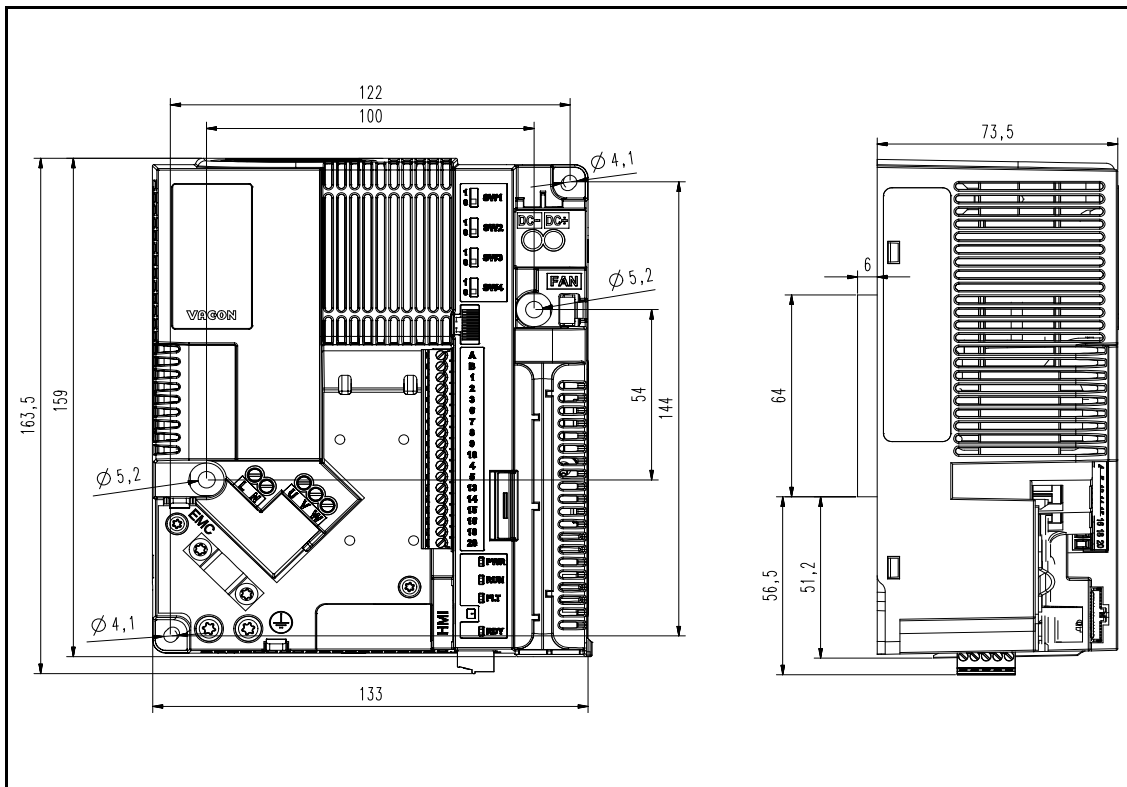

Figure 8. VACON® 20 Cold Plate, MS2 single-phase version.

Table 6.

Enclosure	Dimensions W x H x D	
	[mm]	[in]
MS2	133.0 x 163.5 x 73.5	5.23 x 6.43 x 2.89
MS2 with plate	133.0 x 163.5 x 79.5	5.23 x 6.43 x 3.13

3.1.3 ENCLOSURE MS3

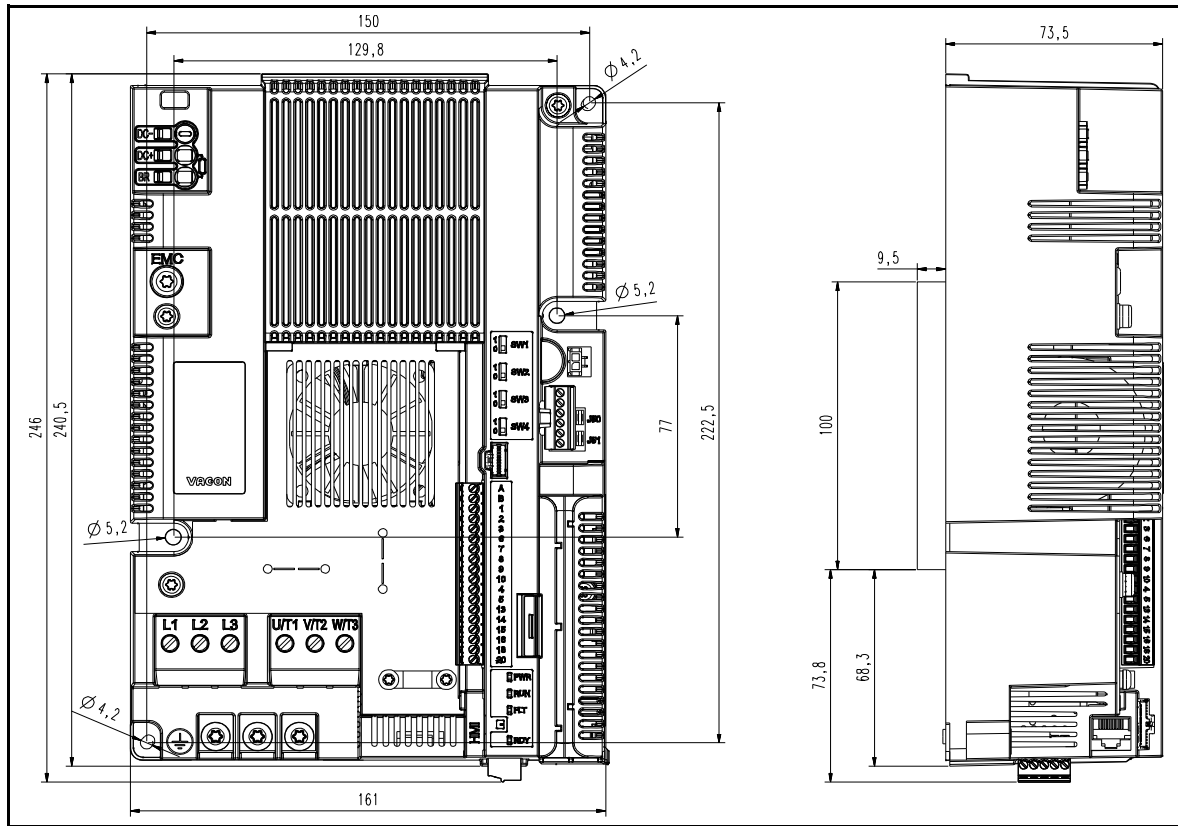

Figure 9. VACON® 20 Cold Plate, MS3.

Table 7.

Enclosure	Dimensions W x H x D	
	[mm]	[in]
MS3	161.0 x 246.0 x 73.5	6.34 x 9.69 x 2.89
MS3 with plate	161.0 x 246.0 x 83.0	6.34 x 9.69 x 3.27

3.2 COOLING

The AC drive produces heat in operation due to the energy dissipation of the electronic components (rectifier and IGBT) and is cooled by a heatsink via the cold plate of the AC drive. The capacity to dissipate this heat mainly depends on the size of the heatsink surface, the environment temperature and the heat transmission resistance. An increase of the heat transmission rate can only be realized to a certain extent by increasing the surface of the heatsink. An additional increase of the heat dissipation by increasing the heatsink is not possible. The AC drive should be mounted with the cold plate on a heatsink with lowest thermal resistance possible.

3.3 ENVIRONMENT TEMPERATURE

The drive environment temperature must not exceed 70 °C (158 °F) for the drive installed location. The aluminium panel of the back of the drive is called "cold plate". The cold plate should never exceed 85 °C (185 °F).



The drive may be damaged if the temperature of the cooling plate exceeds specified tolerance level. Excessive heat can also shorten the performance life of the various AC drive components.

3.4 HEATSINK ASSEMBLY INSTRUCTIONS

The VACON® 20 CP AC drives are designed for installation on surfaces which comply with the specifications listed in this paragraph.

The heatsink surface that is in contact with the AC drive cold plate must be free from dirt and particles. The mating surface flatness must not exceed 50µm (DIN EN ISO 1101) across the entire mating surface, and the roughness less than 6.3 µm (DIN EN ISO 4287). The maximum peak-valley height of the surface shall not exceed 10 µm (DIN EN ISO 4287).

Apply a thermal compound between the heatsink and the AC drive cooling mating surface. The thermal paste assists the drive heat dissipation. We recommend the thermal compounds listed in the following table:

Manufacturer	Type	Model	Recommended spread amount
Wacker Chemie	Silicon paste for heat dissipation	P 12	100 µm Apply the coating evenly across the surface
Fischer Elektronik WLPF	Silicon paste for heat dissipation	WLPF	

Table 8. Recommended cold plate thermal compound.

We recommend screen printing for applying the thermal paste. In certain cases an application by hard rubber roller might be applicable. After mounting the AC drive to the heatsink panel, wipe away any excess compound from around the plate.

Place the VACON® 20 CP on the appropriate heatsink area and tighten the screws as listed in the following table:

Enclosure size	Screw size	Tightening torque N•m (lb•in)
MS2	M5 (according to DIN 7985 - 8.8 (with washer))	2.0 to 2.5 Nm (17.70 to 22.13 lbf•in)
MS3	M5 (according to DIN 7985 - 8.8 (with washer))	2.0 to 2.5 Nm (17.70 to 22.13 lbf•in)

Table 9. Screw size and tightening torque.



Tighten all screws according to specified torques. Failure to do so, may inhibit drive cooling and cause possible damage to the drive.

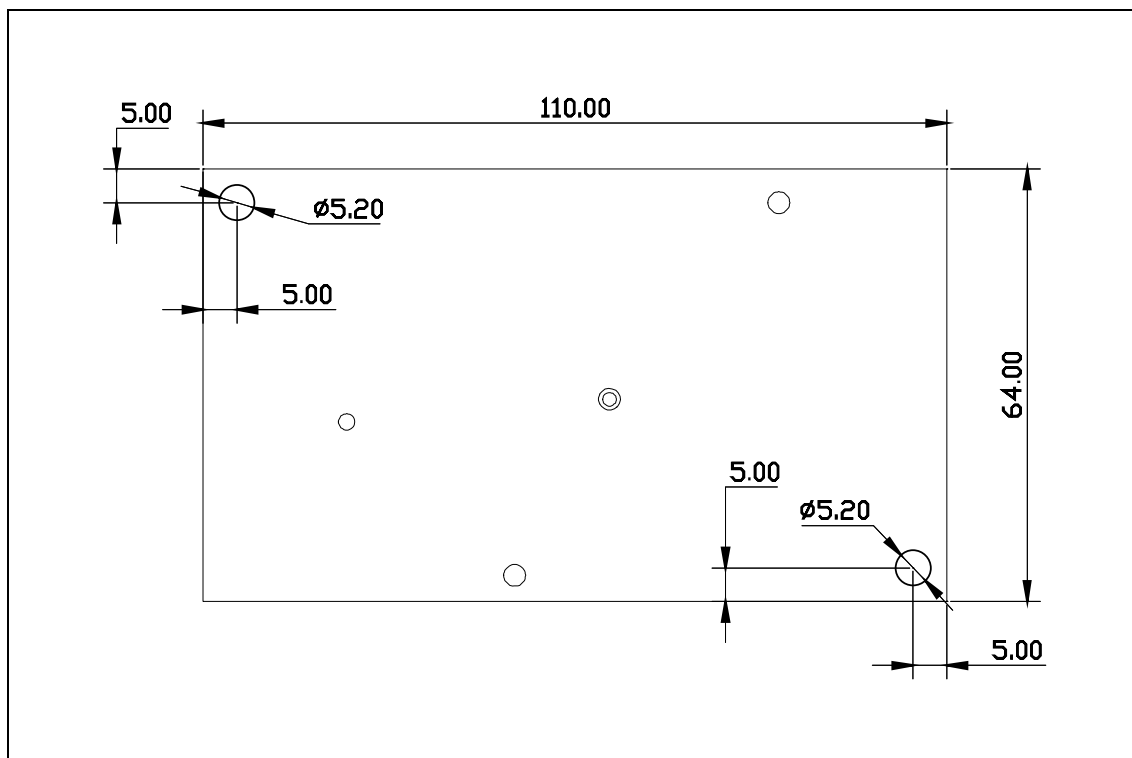

Figure 10. Heatsink plate for MS2 (upper view). The thickness of the plate is 6.0 mm (0.24 in).

Table 10.

Enclosure	Dimensions W x H x D	
	[mm]	[in]
MS2	64.0 x 110.0 x 6.0	2.52 x 4.33 x 0.24

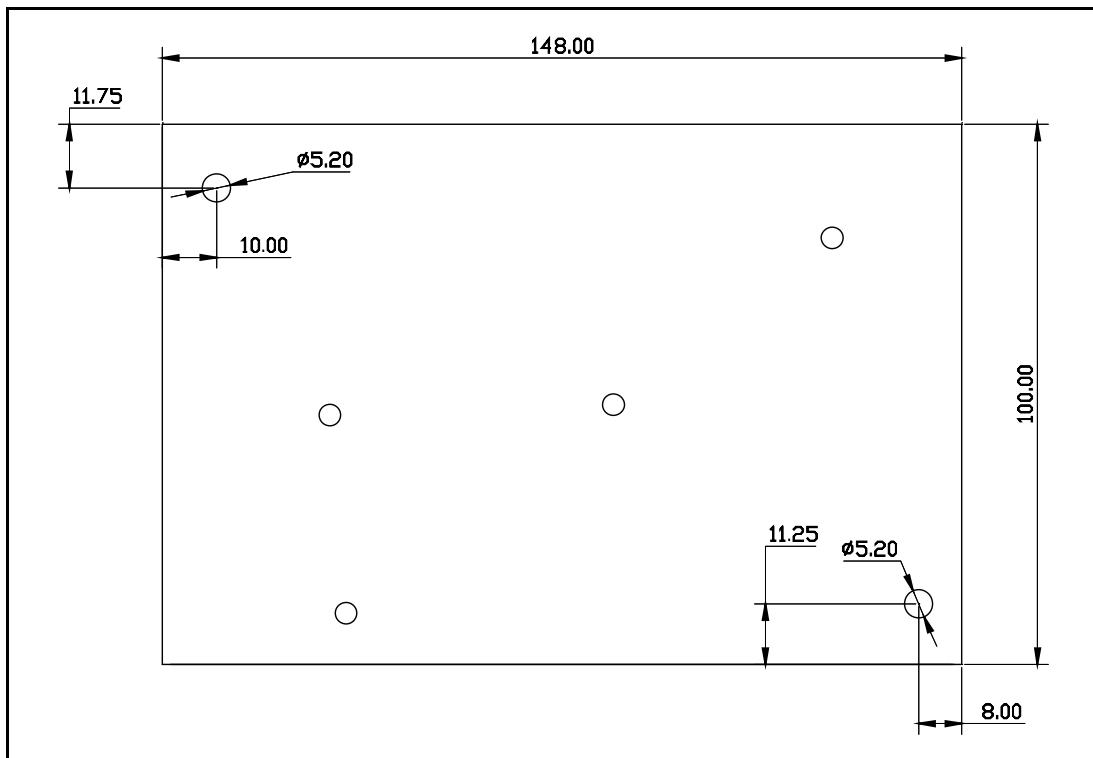

Figure 11. Heatsink plate for MS3 (upper view). The thickness of the plate is 9.5 mm (0.37 in).

Table 11.

Enclosure	Dimensions W x H x D	
	[mm]	[in]
MS3	100.0 x 148.0 x 9.5	3.94 x 5.83 x 0.37

3.5 INSTALLATION SPACING

Enough free must be left space around the AC drive to ensure sufficient air circulation and cooling. Different acts of maintenance may also require a certain amount of free space.

The minimum clearances given in Table 13 must be respected. It is also important to ensure that the temperature of the cooling air does not exceed the maximum environment temperature of the AC drive.

Contact our factory for more information on required clearances in different installations.

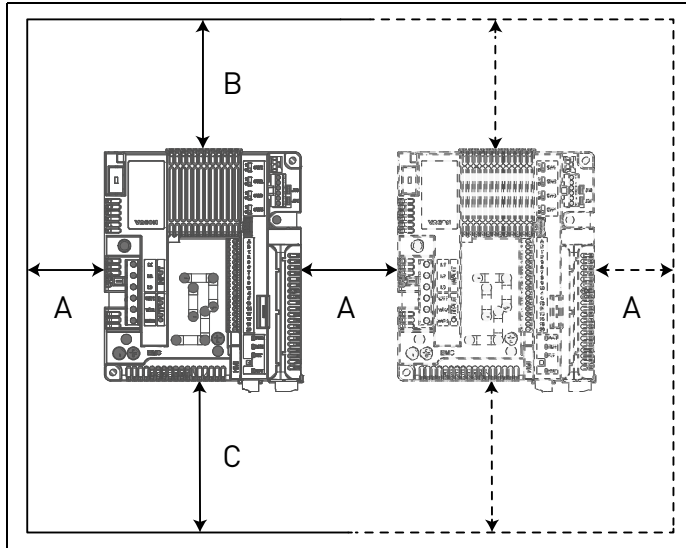

Table 12.

Min clearance mm			
	A		
All types	30	30	30

Table 13. Min. clearances around AC drive.

- A = Clearance left and right from the drive
- B = Clearance above the drive
- C = Clearance underneath the AC drive

Figure 12. Installation space.

3.6 POWER LOSS THERMAL CHARACTERISTICS

In the table below are the thermal characteristics of VACON® 20 CP AC drive at nominal output current. The power loss in stand-by conditions is 12 W for all sizes (supply voltage 24 V, 100 mA).

Mains voltage 3AC 208-240V, 50/60 Hz					
Enclosure	AC drive Type	Rated output current [A]	Cold plate loss [W]	Internal loss [W]	Total loss [W]
MS2	0004	3.7	27	18	45
	0005	4.8	37	21	58
	0007	7.0	58	30	88
MS3	0011	11.0	85	28	113
	0012	12.5	101	37	138
	0017	17.5	146	50	196

Table 14. Drive power loss at rated conditions, voltage range 3AC 208-240V.

Mains voltage 1AC 208-240V, 50/60 Hz					
Enclosure	AC drive Type	Rated output current [A]	Cold plate loss [W]	Internal loss [W]	Total loss [W]
MS2	0004	3.7	31	22	53
	0005	4.8	37	24	61
	0007	7.0	59	31	90

Table 15. Drive power loss at rated conditions, voltage range 1AC 208-240V.

Mains voltage 3AC 380-480V, 50/60 Hz					
Enclosure	AC drive Type	Rated output current [A]	Cold plate loss [W]	Internal loss [W]	Total loss [W]
MS2	0003	2.4	23	16	39
	0004	3.3	31	18	49
	0005	4.3	43	21	64
	0006	5.6	58	25	83
	0008	7.6	84	33	117
MS3	0009	9.0	86	31	117
	0012	12.0	120	37	157
	0016	16.0	171	48	219

Table 16. Drive power loss at rated conditions, voltage range 3AC 380-480V.

3.7 DIMENSIONING AN EXTERNAL HEATSINK

This paragraph describes a useful procedure to select a suitable heatsink for VACON® 20 CP drives. The heatsinks are devices that enhance heat dissipation from a hot surface, usually the case of a heat generating component, to a cooler ambient, usually air. For the following discussion, air is assumed to be the cooling fluid. The primary purpose of a heatsink is to maintain the device temperature below the maximum allowable specified by the device manufacturers. Before discussing the heatsink selection process, it is necessary to define common terms, notations and definitions and establish the concept of a thermal circuit.

Notations and definitions of the terms are as follows:

Symbol	Description
CP_{loss}	Cold plate loss: see Table 14, Table 15 or Table 16 expressed in W
T_{CPmax}	Maximum cold plate temperature expressed in °K (358 °K = 85°C)
T_{amb}	heatsink ambient temperature expressed in °K(°K = °C + 273)
R_{CP}	Equivalent thermal resistance [K/W] of the cold plate.
R_{HSmax}	Thermal resistance of the heatsink [K/W]

Table 17. Terms and definitions for the thermal model.

The purpose of this paragraph is to select an external heatsink by calculating its thermal resistance. The heat transfer principle from the cold plate to the heatsink ambient air is shown in Figure 13.

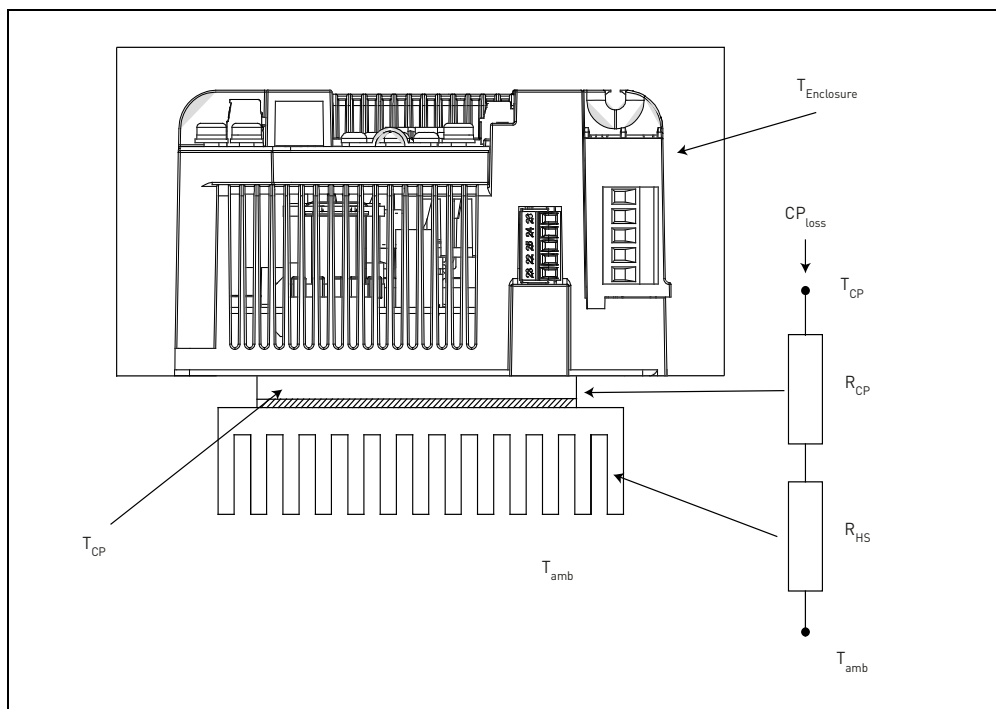

Figure 13. Thermal equivalent circuit.

The formula to calculate the maximum thermal resistance of the heatsink is as follows:

$$R_{HSmax} = \frac{T_{CPmax} - T_{amb}}{CP_{loss}} - R_{CP}$$

For a given ambient temperature T_{amb} the cold plate temperature T_{CPmax} must not exceed the maximum allowable value (85°C). As the R_{CP} is essentially fixed, this condition must be satisfied with a proper heatsink selection. The table below shows the typical values for R_{CP} for VACON® 20 CP:

Enclosure	R_{CP}
MS2	$R_{CP}=0.091$ K/W
MS3	$R_{CP}= 0,055$ K/W

Table 18. Typical values for the equivalent thermal resistances of the cold plate.

Select a heatsink with a smaller thermal resistance than R_{HSmax} . The heatsink dimensions should be closed to the cold plate dimensions.



If the heatsink height and width are much larger than the drive cold plate dimensions, or if multiple drives are installed on one heatsink, it may be necessary to apply correction factors to the thermal resistance value given in the heatsink specification. Contact the heatsink manufacturer.

Note: remember that the heatsink cooling capacity can be reduced over time due to dirt.

In order to choose an heatsink from a catalogue please consider that usually the reported heat resistances are measured under free convection conditions. In this case the heatsink has to be oversized with respect to the cold plate dimensions, otherwise an additional fan must be used to reduce the heatsink resistance and its dimensions. Most heatsink manufacturers give correction factors according to various air flow speeds.

The designing factors which influence the thermal performances of an heatsink are as follows:

- **Spreading resistance:** Spreading resistance occurs when thermal energy is transferred from a small area to a larger area in a substance with finite thermal conductivity. In a heatsink, this means that heat does not distribute uniformly through the heatsink base. The spreading resistance phenomenon is shown by how the heat travels from the heat source location and causes a large temperature gradient between the heat source and the edges of the heatsink. This means that some fins are at a lower temperature than if the heat source were uniform across the base of the heatsink. This non uniformity increases the heatsink's effective thermal resistance.
- **Heatsink manufacturer dimensioning data:** the heatsink thermal resistance given in a catalogue is measured on a temperature sink to ambient differential (ΔT) and since R_{hs} under free convection depends on ΔT with the power law $R_{th} \sim \Delta T^{-0.25}$ (with laminar flow), a correction factor must be considered when the operating ΔT is different from what used by the heatsink manufacturer in the measurement.
- **Surface finishing:** the heatsink dissipation depends on the type of surface finishing of heatsink itself (anodized/black surfaces dissipate differently from polished surfaces).

- **Heatsink attachment/orientation:** heatsink attachment/orientation plays a significant role under natural convection. It is recommended that the heatsink be installed to orient the fins in a direction that will not block air movement under natural convection. Based practical experience, if the heatsink is oriented in a wrong way, the thermal performance will be approximately 25% worse under natural convection condition.



Taking account of the above, we recommend that the calculated R_{HS} is multiplied by 0.7 to obtain a resistance value with a reasonable safety margin in order to ensure triplex drive operation.

Note: to study the heat transfer in other cooling media of different geometry (e.g. cooling plate without fins), please contact your local distributor to receive support in dimensioning method.

4. POWER CABLING

The mains cables are connected to terminals L1, L2 and L3 (three-phase versions) and the motor cables to terminals marked with U, V and W. See principal connection diagram in Figure 14. See also Table 19 for the cable recommendations for different EMC levels.

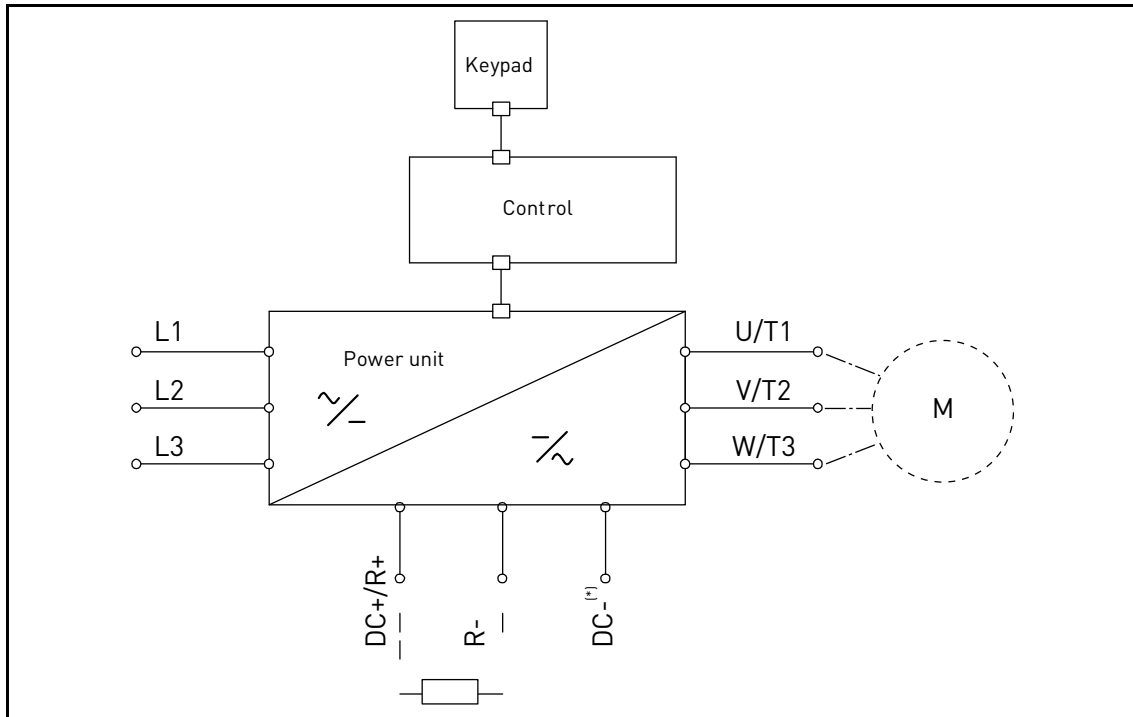

Figure 14. Principal connection diagram (three-phase version).

* only MS3.

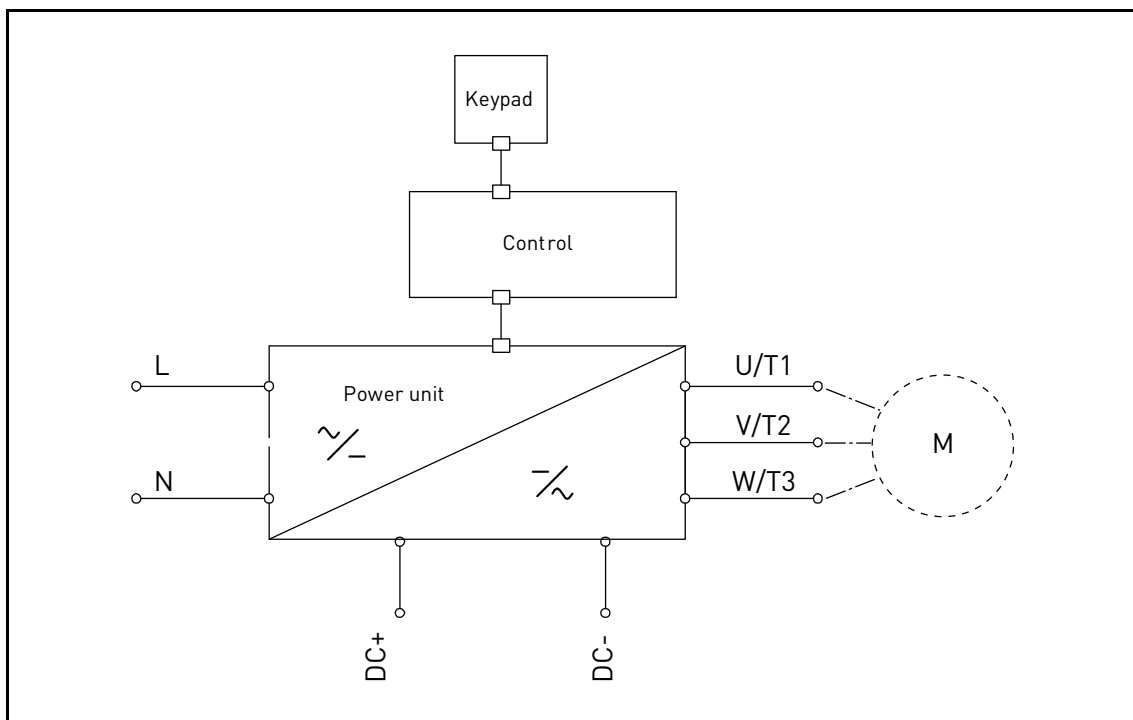

Figure 15. Principal connection diagram (single-phase version)

Use cables with heat resistance in accordance with the application requirements. The cables and the fuses must be dimensioned according to the AC drive nominal OUTPUT current which you can find on the rating plate.

Cable type	EMC levels		
	1 st environment	2 nd environment	
	Category C1 and C2	Category C3	Category C4
Mains cable	1	1	1
Motor cable	3*	2	2
Control cable	4	4	4

Table 19: Cable types required to meet standards.

- 1 = Power cable intended for fixed installation and the specific mains voltage. Shielded cable not required. (MCMK or similar recommended).
- 2 = Symmetrical power cable equipped with concentric protection wire and intended for the specific mains voltage. (MCMK or similar recommended). See Figure 16.
- 3 = Symmetrical power cable equipped with compact low-impedance shield and intended for the specific mains voltage. [MCCMK, EMCMK or similar recommended; Recommended cable transfer impedance (1...30MHz) max. 100mohm/m]. See Figure 16.
- *360° grounding of the shield with cable glands in motor end needed for EMC category C1 and C2.
- 4 = Screened cable equipped with compact low-impedance shield (JAMAK, SAB/ÖZCuY-0 or similar).

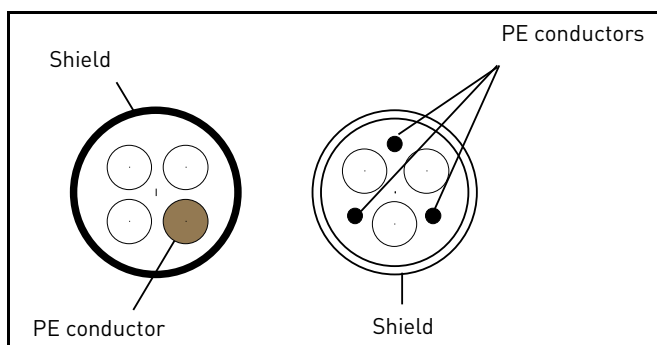

Figure 16. Example with three-phase cable.

NOTE: The EMC requirements are fulfilled at factory defaults of switching frequencies (all enclosures).

NOTE: If safety switch is connected the EMC protection shall be continuous over the whole cable installation.

4.1 CIRCUIT BREAKER

Please disconnect the drive via an external circuit breaker. You have to provide a switching device between supply and main connection terminals.

When connecting the input terminals to the power supply using a circuit breaker, observe that this is of **type B or type C** and ensure it has a **capacity of 1.5 to 2 times the inverter's rated current** (see Chapter 7.1).

NOTE: circuit breaker is not allowed in installations where C-UL is required. Only fuses are recommended.

4.2 UL STANDARDS ON CABLING

To meet the UL (Underwriters Laboratories) regulations, use a UL-approved copper cable with a minimum heat-resistance of 75°C. Use Class 1 wire only.

The units are suitable for use on a circuit capable of delivering no more than 50,000 rms symmetrical amperes, 500V AC maximum, when protected by T or J class fuses.



Integral solid state short circuit protection does not provide branch circuit protection. Branch circuit protection must be provided in accordance with the **National Electrical Code** and any additional local codes.

4.3 DESCRIPTION OF THE TERMINALS

The following pictures describe the power terminals and the typical connections in VACON® 20 CP drives.

4.3.1 MS2 THREE-PHASE VERSION POWER CONNECTIONS

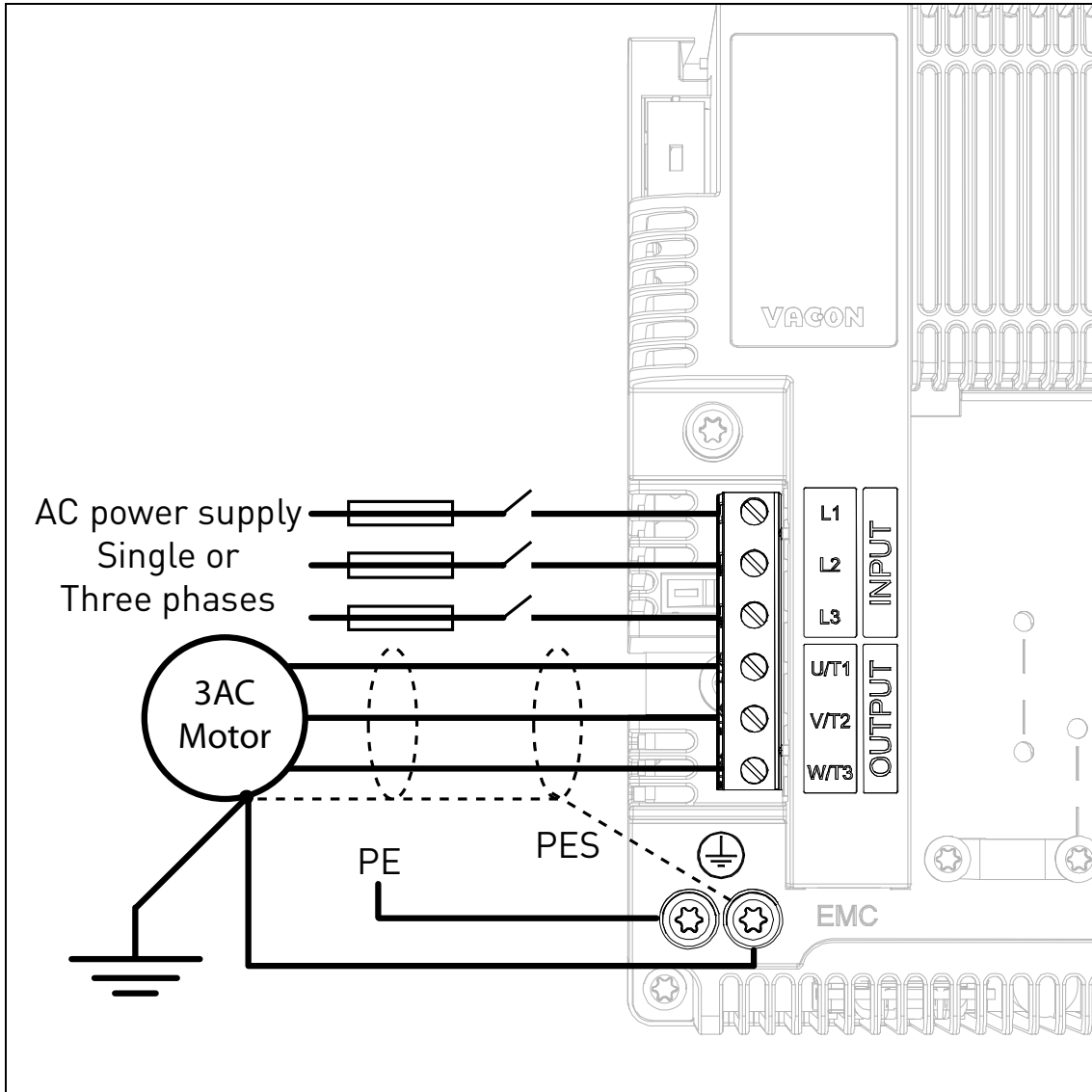

Figure 17. Power connections, MS2 three-phase version.

Terminal	Description
L1 L2 L3	These terminals are the input connections for the power supply. 230 VAC models can be supplied by single-phase voltage by connecting to L1 and L2 terminals (with derating of 50%).
U/T1 V/T2 W/T3	These terminals are for motor connections.

Table 20. Description of VACON® 20CP MS2 power terminals.

4.3.2 MS2 SINGLE-PHASE VERSION POWER CONNECTIONS

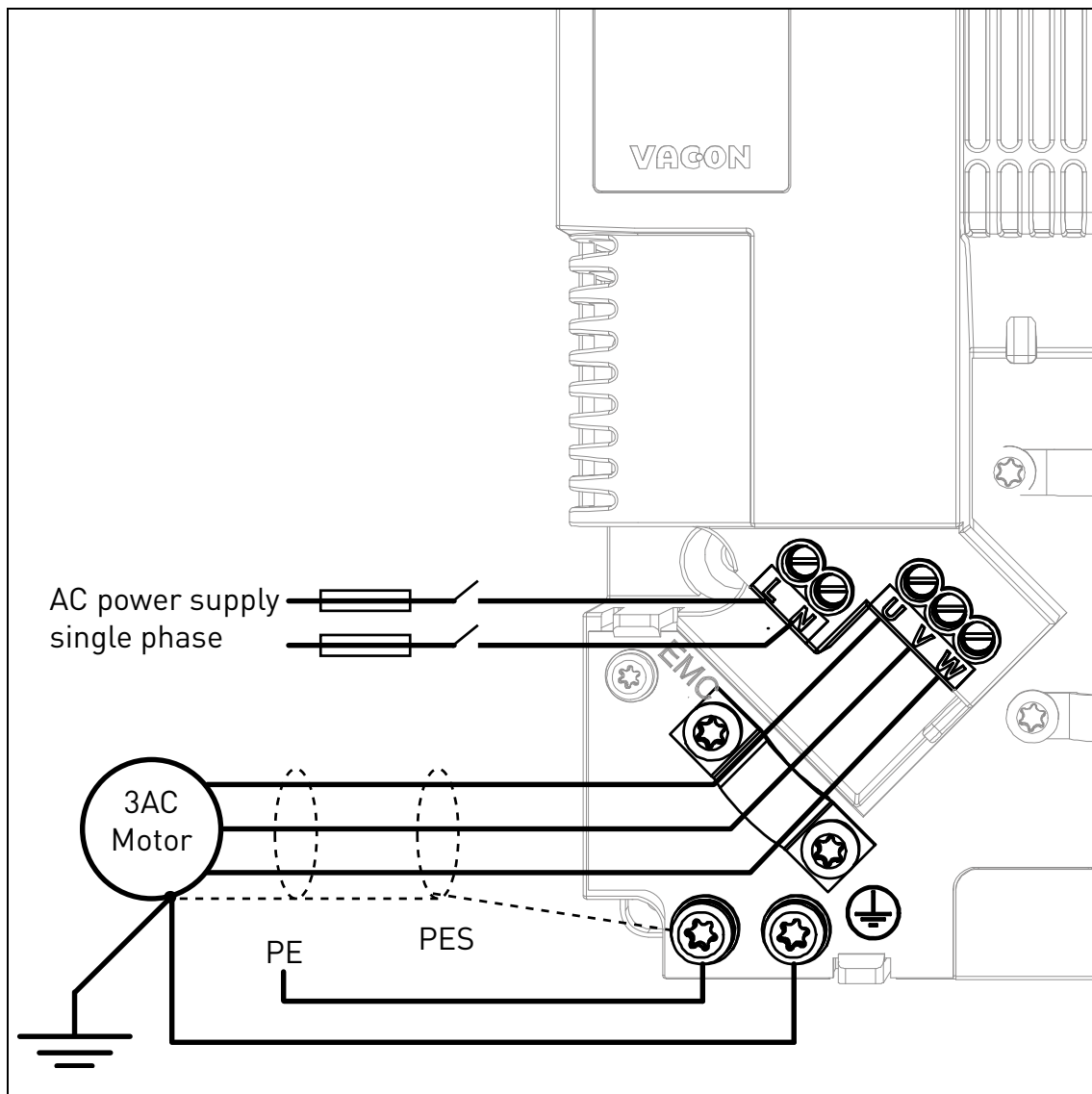

Figure 18. Power connections, MS2 single-phase version.

Terminal	Description
L N	These terminals are the input connections for the power supply. Single-phase 230 VAC voltage has to be connected to L and N terminals.
U V W	These terminals are for motor connections.

Table 21. Description of VACON® 20CP MS2 power terminals (single-phase version).

4.3.3 MS3 POWER CONNECTIONS

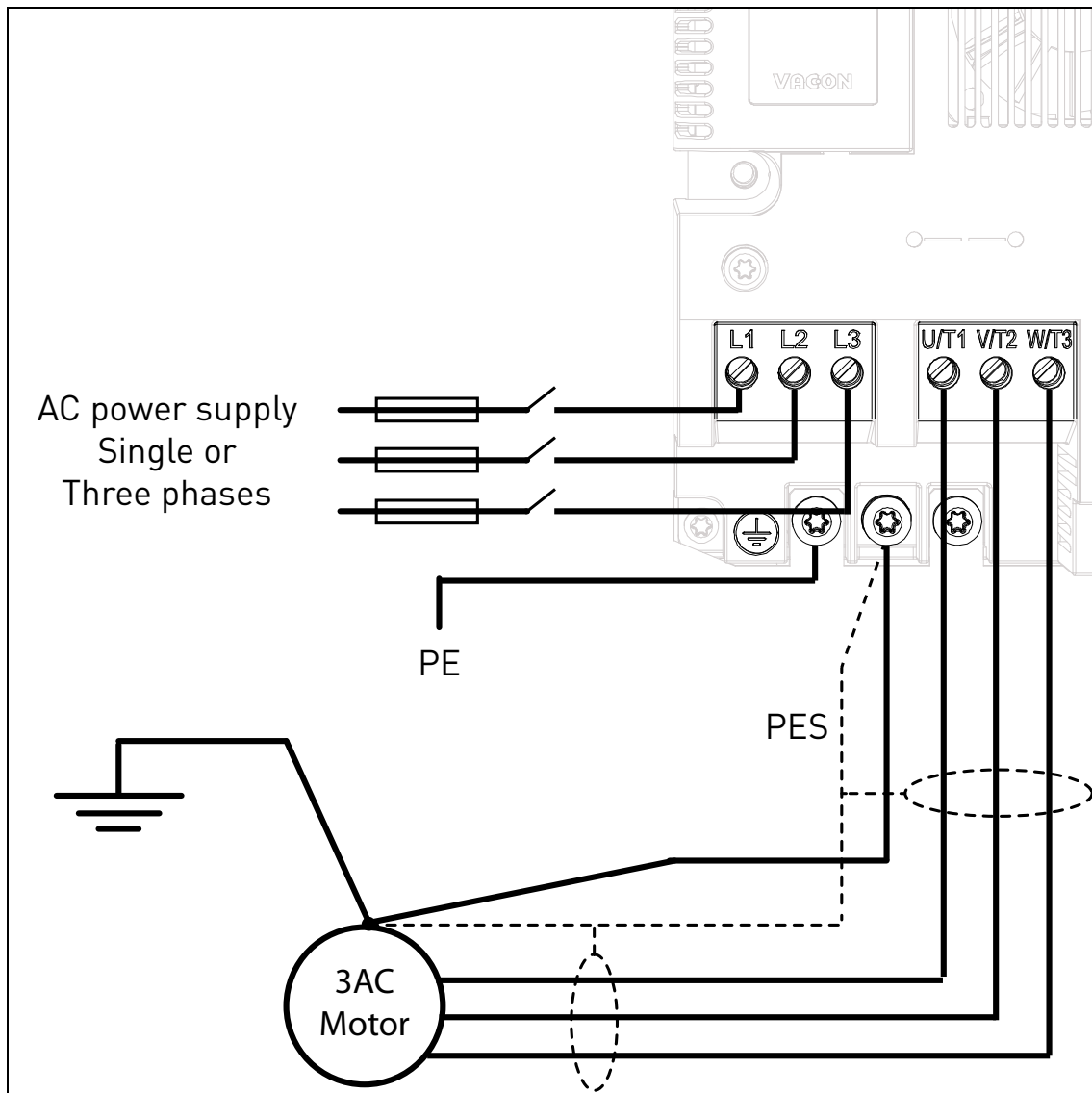

Figure 19. Power connections, MS3.

Terminal	Description
L1 L2 L3	These terminals are the input connections for the power supply. 230 VAC models can be supplied by single-phase voltage by connecting to L1 and L2 terminals (with derating of 50%).
U/T1 V/T2 W/T3	These terminals are for motor connections.

Table 22. Description of VACON® 20CP MS3 power terminals.

4.4 CABLE DIMENSIONING AND SELECTION

Table 23 shows the minimum dimensions of the Cu-cables and the corresponding fuse sizes.

These instructions apply only to cases with one motor and one cable connection from the AC drive to the motor. In any other case, ask the factory for more information.

4.4.1 CABLE AND FUSE SIZES, ENCLOSURES MS2 TO MS3

The recommended fuse types are gG/gL (IEC 60269-1) or class T (UL & CSA). The fuse voltage rating should be selected according to the supply network. The final selection should be made according to local regulations, cable installation conditions and cable specifications. Bigger fuses than those recommended below must not be used.

Check that the fuse operating time is less than 0.4 seconds. Operating time depends on used fuse type and impedance of the supply circuit. Consult the factory about faster fuses. We also recommend high speed J (UL & CSA), aR (UL recognized, IEC 60269-4) and gS (IEC 60269-4) fuse ranges.

Table 23. Cable and fuse sizes for VACON® 20 CP.

Enclosure	Type	I _{INPUT} [A]	Fuse (gG/gL) [A]	Mains and motor cable Cu [mm ²]	Terminal cable size	
					Main terminal [mm ²]	Earth terminal
MS2	0004 2 0003 4 - 0004 4	4.3 3.2 - 4.0	6	3*1.5+1.5	0.2 — 2.5	M4 ring terminal
	0005 2 - 0007 2 0005 4 - 0006 4	6.8 - 8.4 5.6 - 7.3	10	3*1.5+1.5	0.2 — 2.5	M4 ring terminal
	0008 4	9.6	16	3*2.5+2.5	0.2 — 2.5	M4 ring terminal
MS2 1-phase	0004 2	8.3	20	(Mains) 2*1.5+1.5 (Motor) 3*1.5+1.5	0.2 — 2.5 stranded	M4 ring terminal
	0005 2	11.2	20	(Mains) 2*2.5+2.5 (Motor) 3*2.5+2.5	0.2 — 2.5 stranded	M4 ring terminal
	0007 2	14.1	25	(Mains) 2*2.5+2.5 (Motor) 3*2.5+2.5	0.2 — 2.5 stranded	M4 ring terminal
MS3	0011 2 0009 4	13.4 11.5	16	3*2.5+2.5	0.5 — 16.0	M5 ring terminal
	0012 2 0012 4	14.2 14.9	20	3*2.5+2.5	0.5 — 16.0	M5 ring terminal
	0017 2 0016 4	20.6 20.0	25	3*6+6	0.5 — 16.0	M5 ring terminal

The cable dimensioning is based on the criteria of the International Standard **IEC60364-5-52**: Cables must be PVC-isolated; use only cables with concentric copper shield; Max number of parallel cables is 9.

When using cables in parallel, **NOTE HOWEVER** that the requirements of both the cross-sectional area and the max number of cables must be observed.

For important information on the requirements of the grounding conductor, see chapter Grounding and earth fault protection of the standard.

For the correction factors for each temperature, see International Standard **IEC60364-5-52**.

4.4.2 CABLE AND FUSE SIZES, ENCLOSURES MS2 TO MS3, NORTH AMERICA

The recommended fuse types are gG/gL (IEC 60269-1) or class T (UL & CSA). The fuse voltage rating should be selected according to the supply network. The final selection should be made according to local regulations, cable installation conditions and cable specifications. Bigger fuses than those recommended below shall not be used.

Check that the fuse operating time is less than 0.4 seconds. Operating time depends on used fuse type and impedance of the supply circuit. Consult the factory about faster fuses. We also recommend high speed J (UL & CSA), aR (UL recognized, IEC 60269-4) and gS (IEC 60269-4) fuse ranges.

Table 24. Cable and fuse sizes for VACON® 20 CP, North America.

Enclosure	Type	I _{INPUT} [A]	Fuse (class T) [A]	Mains and motor cable Cu	Terminal cable size	
					Main terminal	Earth terminal
MS2	0004 2	4.3	6	AWG14	AWG24-AWG12	AWG17-AWG10
	0003 4 - 0004 4	3.2 - 4.0				
	0005 2 - 0007 2 0005 4 - 0006 4	6.8 - 8.4 5.6 - 7.3	10	AWG14	AWG24-AWG12	AWG17-AWG10
	0008 4	9.6	15	AWG14	AWG24-AWG12	AWG17-AWG10
MS2 1-phase	0004 2	8.3	20	AWG14	AWG24-AWG12	AWG17-AWG10
	0005 2	11.2	20	AWG14	AWG24-AWG12	AWG17-AWG10
	0007 2	14.1	25	AWG14	AWG24-AWG12	AWG17-AWG10
MS3	0011 2	13.4	15	AWG14	AWG20-AWG6	AWG17-AWG10
	0009 4	11.5				
	0012 2	14.2	20	AWG12	AWG20-AWG6	AWG17-AWG10
	0012 4	14.9				
	0017 2	20.6	25	AWG10	AWG20-AWG6	AWG17-AWG10
0016 4	20.0					

The cable dimensioning is based on the criteria of the **Underwriters' Laboratories UL508C**:Cables must be PVC-isolated; Max ambient temperature +30 °C, max temperature of cable surface +70 °C; Use only cables with concentric copper shield; Max number of parallel cables is 9.

When using cables in parallel, **NOTE HOWEVER** that the requirements of both the cross-sectional area and the max number of cables must be observed.

For important information on the requirements of the grounding conductor, see standard Underwriters' Laboratories UL508C.

For the correction factors for each temperature, see the instructions of standard **Underwriters' Laboratories UL508C**.

4.5 BRAKE RESISTOR CABLES

VACON® 20 CP AC drives (three-phase version) are equipped with terminals for an optional external brake resistor. These terminals are 6.3 mm Faston for MS2 and spring-type terminals for MS3. See Figure 21 and Figure 23 for the location of these terminals.

See Table 43 and Table 44 for the resistor ratings.

4.6 CONTROL CABLES

For information on control cables see chapter Control unit cabling.

4.7 CABLE INSTALLATION

- Before starting, check that none of the components of the AC drive is live. Read the warnings in chapter 1 carefully
- Place the motor cables sufficiently far from other cables
- Avoid placing the motor cables in long parallel lines with other cables.
- If the motor cables run in parallel with other cables note the minimum distances between the motor cables and other cables given in table below.

Table 25.

Distance between cables, [m]	Shielded cable, [m]
0.3	≤ 50
1.0	≤ 200

- The given distances also apply between the motor cables and signal cables of other systems.
- The **maximum length** for motor cables is **30m**
- The motor cables should cross other cables at an angle of 90 degrees.
- If cable insulation checks are needed, see chapter Cable and motor insulation checks.

Start the cable installation according to the instructions below:

1	Strip the motor and mains cables as recommended below.
----------	--

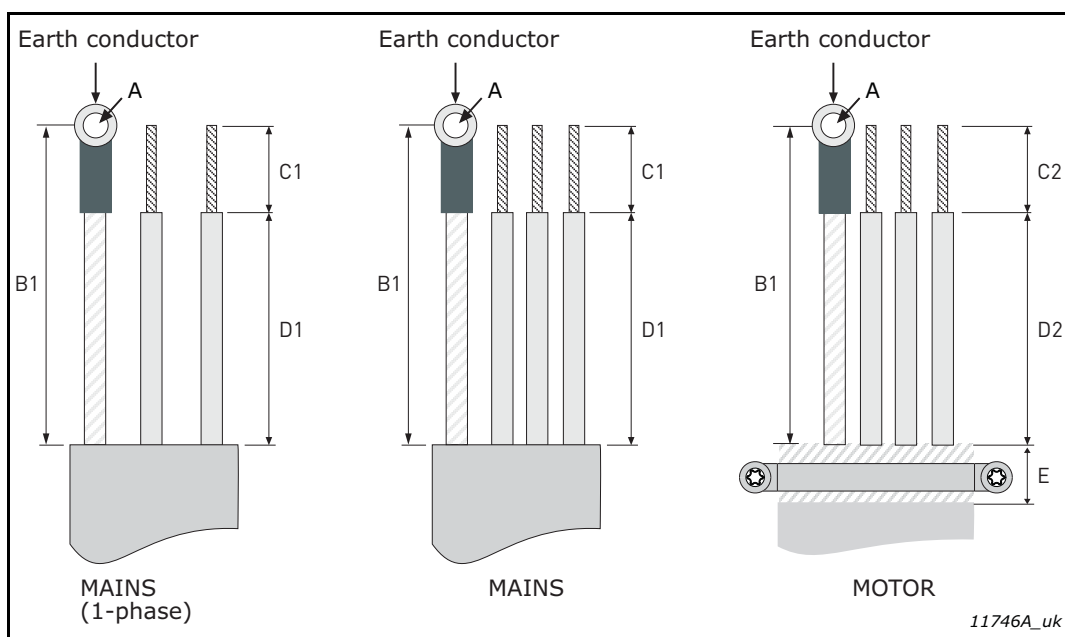

Figure 20. Stripping of cables.

Table 26. Cables stripping lengths [mm].

Enclosure	A1	B1	C1	D1	C2	D2	E
MS2	8	8	8	20	36	20	Leave as short as possible
MS2 1-phase	7	8	8	20	36	20	
MS3	8	8	8	20	36	20	

2	<p>Connect the stripped cables:</p> <ul style="list-style-type: none"> • Expose the shield of both cables in order to make a 360-degree connection with the cable clamp. • Connect the phase conductors of the supply and motor cables into their respective terminals. • Form the rest of the cable shield of both cables into “pigtailed” and make a grounding connection with the clamp. Make the pigtailed just long enough to reach and be fixed to the terminal - no longer.
----------	---

Tightening torques of cable terminals:

Table 27. Tightening torques of terminals

Enclosure	Type	Tightening torque Power and motor terminals		Tightening torque EMC grounding clamps		Tightening torque, Grounding terminals	
		[Nm]	lbs-in.	[Nm]	lbs-in.	[Nm]	lbs-in.
MS2	0003 4—0008 4	0.5—0.6	4.5—5.3	1.5	13.3	2.0	17.7
	0004 2—0007 2						
MS3	0009 4—0016 4	1.2—1.5	10.6—13.3	1.5	13.3	2.0	17.7
	0011 2—0017 2						

5. CONTROL UNIT

The control unit of the AC drive consists of the control board and additional boards (option boards) connected to the slot connectors of the control board. The locations of boards, terminals and switches are presented in Figure 21, Figure 22 and Figure 23.

Number	Meaning
1	Control terminals A-20
2	STO terminals (only in three-phase version)
3	Relay terminals
4	Option board terminals
5	STO Jumpers (only in three-phase version)
6	DIP switches
7	Status LEDs
8	HMI connector (RJ45 keypad connector)*
9	Optional brake resistor terminals
10	Supply voltage connector for main cooling fan
11	Control terminals A-20 echo connector
12	HMI echo connector (keypad connector)
13	DC-bus terminals

Table 28. Locations of components in control unit



* The HMI connector is only to connect the keypad and not for Ethernet communication.

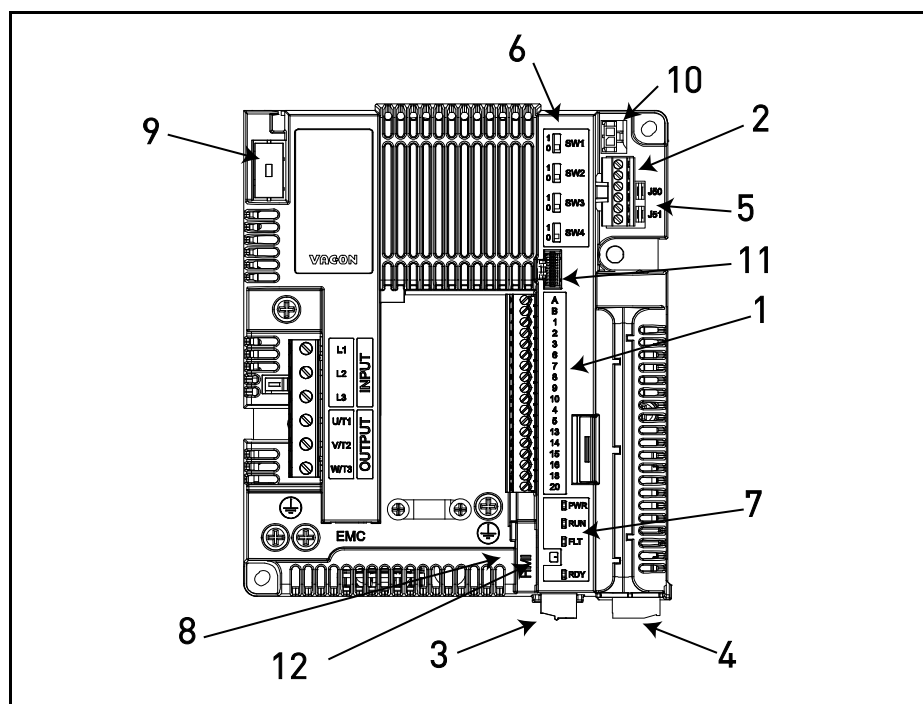

Figure 21. Locations of the components in control unit of MS2 (three-phase version).

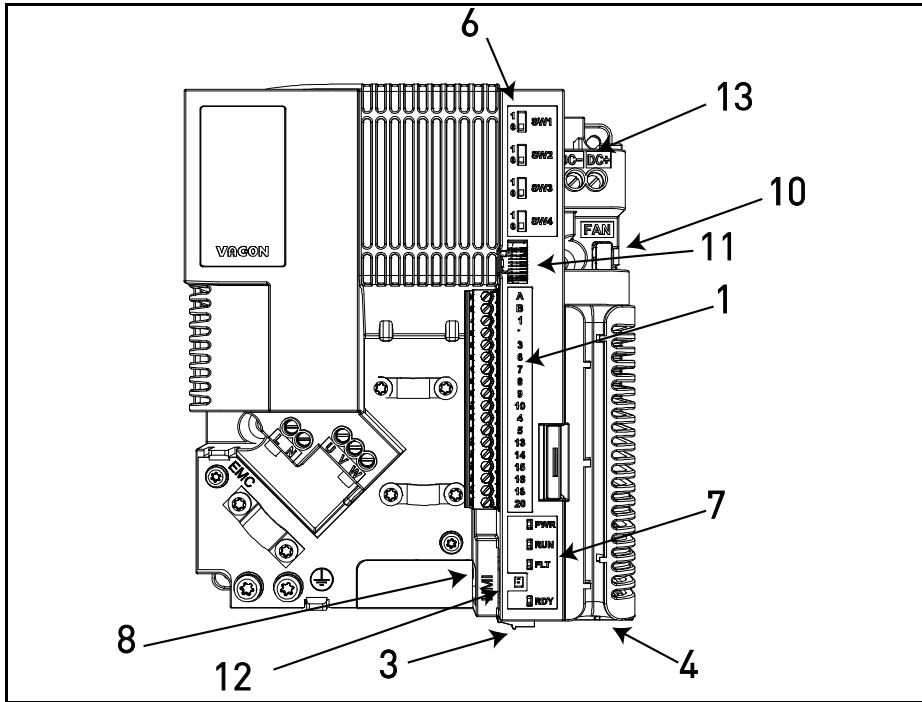

Figure 22. Locations of the components in control unit of MS2 (single-phase version).

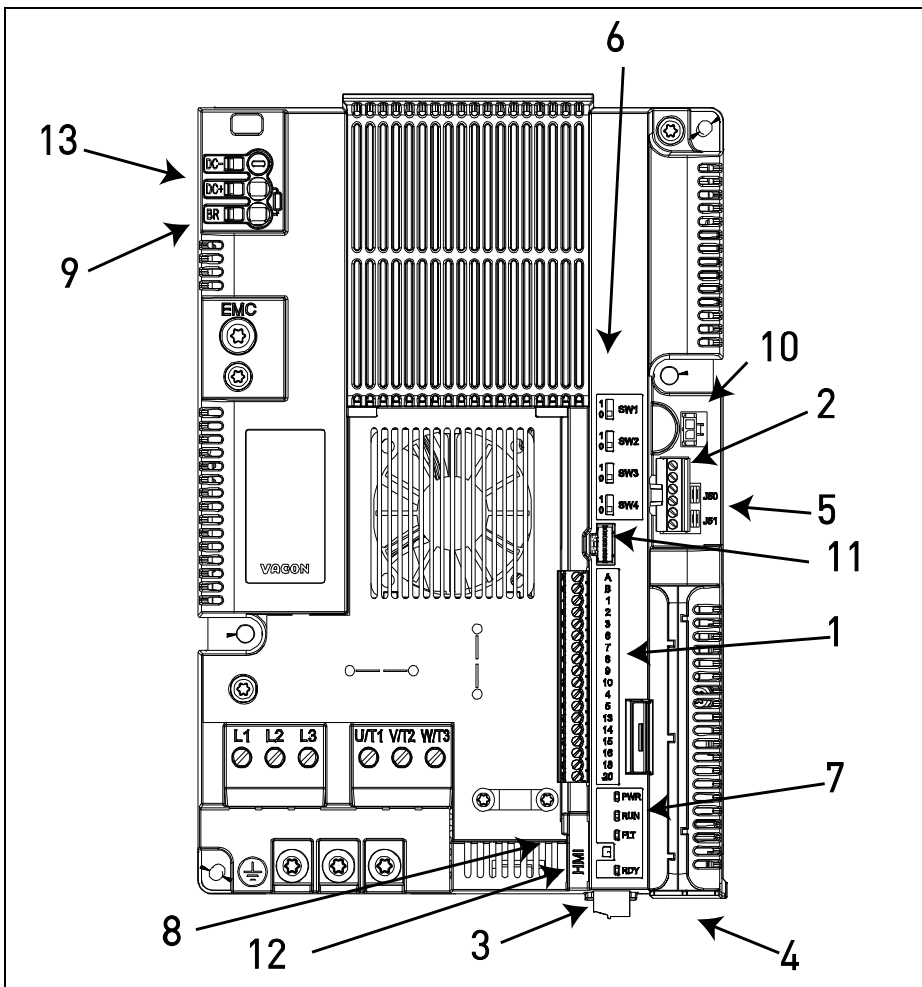

Figure 23. Location of the components in the control unit of MS3.

When delivered from the factory, the control unit of the AC drive contains the standard controlling interface - the control terminals of the control board - unless otherwise specifically ordered. In the following pages you will find the arrangement of the control I/O and the relay terminals, the general wiring diagram and the control signal descriptions.

The control board can be powered externally by connecting an external power source (about 130-150mA at 24VDC are needed to supply the control board without keypad, option board or other loads) between terminal #6 and GND, see chapter 5.1.2. To ensure that the external supply works with any configurations we recommend to use an external supply of +24VDC ±10%, 1000mA overcurrent protected.

This voltage is sufficient for parameter setting and for keeping the control unit active. Note however that the values of the measurements of the main circuit (e.g. DC-link voltage, unit temperature) are not available when the mains is not connected.

In addition to the internal fan, VACON® 20 CP AC drives include an auxiliary fan power supply connector (see 10 in the Figure 21, Figure 22 and Figure 23) for improved air flow and system cooling. The power supply also has automatic thermal switching on/off control: it automatically switches on/off depending on internal cold plate temperature. The electric specifications for the auxiliary fan power supply are shown in the following table:

Terminals	Signals	
	MS2	MS3
FAN+	24VDC ±10% maximum output current 200mA	24VDC ±10% maximum output current 700mA
FAN-	GND	GND

Table 29. Electric specifications for the auxiliary fan power supply.

The connector for the auxiliary fan supply is a Micro-Fit 3.0™ Header, Surface Mount Compatible, Single Row, Vertical with PCB Polarizing Peg by Molex (part number 43650-0215). This connection is echoed in the HMI echo connector. See Figure 21, Figure 22 and Figure 23 for the location of the connectors and Table 35 for the description of the HMI echo terminal.

To connect the auxiliary fan to VACON® 20 CP drives you will need a Micro-Fit 3.0™ Receptacle Crimp Housing, Single Row by Molex® (part number 43645-0200). See the picture below for more details.

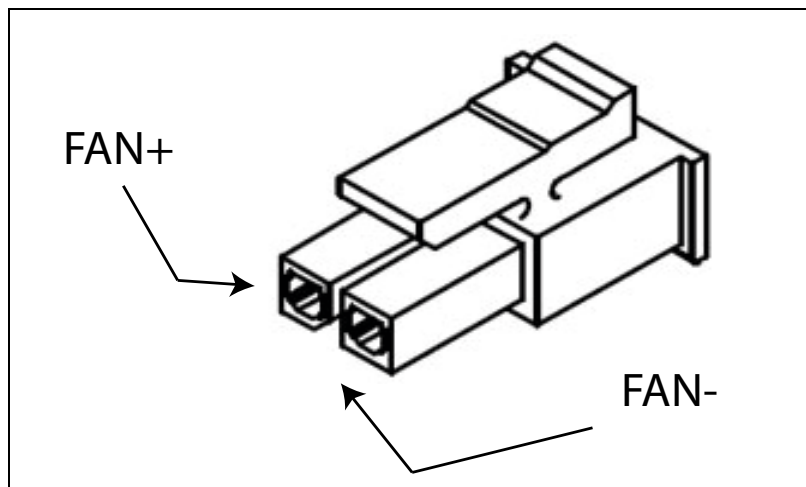

Figure 24. Micro-Fit 3.0™ Housing.

5.1 CONTROL UNIT CABLING

The principal terminal block placement is shown in Figure 25 below. The control board is equipped with 23 fixed control I/O terminals. Additionally, the terminals for the Safe Torque Off (STO) function (see chapter 9) can be seen in the picture below. All signal descriptions are also given in Table 31.

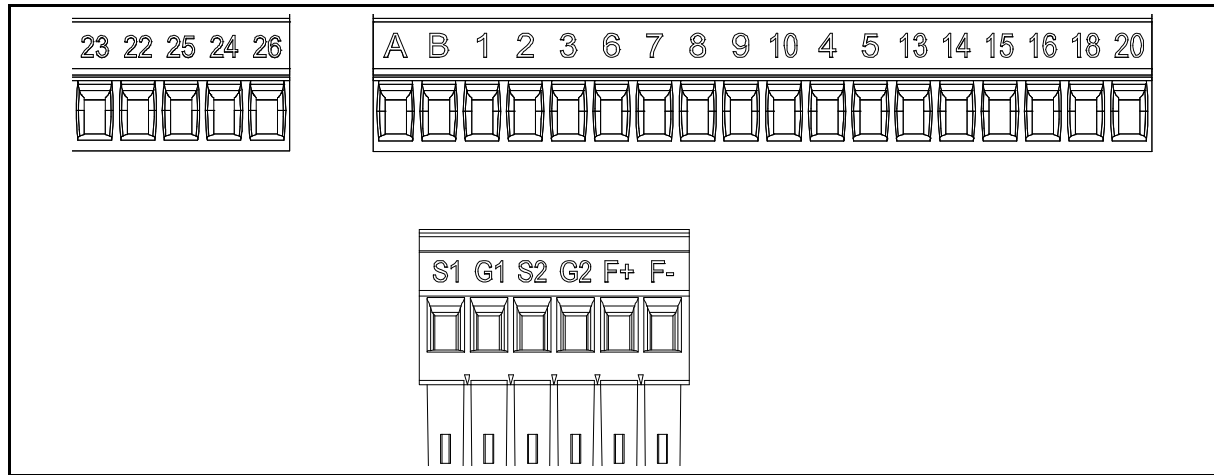

Figure 25. Control terminals.

5.1.1 CONTROL CABLE SIZING

The I/O (control and relays) and STO cables must be screened multi core cables with following cable sizes:

- 0.14...1.5 mm² without ferrules
- 0.25...1.5 mm² with ferrules (no plastic neck)
- 0.25...1.5 mm² with ferrules (with plastic neck)

Find the tightening torques of the I/O (control and relays) and STO terminals in the Table below.

Terminal screw	Tightening torque	
	Nm	lbs-in.
I/O terminals and STO terminals (screw M2)	0.22 min 0.25 max	1.95 min 2.21 max

Table 30. Control cable tightening torques.

5.1.2 STANDARD I/O TERMINALS

The terminals of the *Standard I/O* are described below. For more information on connections, see chapter 7.3.1.

The terminals shown on shadowed background are assigned for signals with optional functions selectable with DIP switches. For more information, see chapter 5.1.7.

Table 31. Control I/O terminal signals and connection example.

The diagram illustrates the connection of external components to the control unit terminals. A reference potentiometer (1...10kΩ) is connected to terminals A and B. A remote reference (4...20mA/0...10V) is connected to terminals 1 and 2. A voltage measurement point X1 is connected to terminals 4 and 5. The diagram also shows several digital input terminals (DI1-DI6) and a digital output terminal (DO1+).

Standard I/O terminals		
Terminal		Signal
A	RS485_A	Serial bus, negative
B	RS485_B	Serial bus, positive
1	+10 Vref	Reference output
2	AI1+	Analogue input, voltage or current
3	GND	I/O signal ground
6	24Vout	24V aux. voltage
7	DIN COM	Digital inputs common
8	DI1	Digital input 1
9	DI2	Digital input 2
10	DI3	Digital input 3
4	AI2+	Analogue input, voltage or current
5	GND	I/O signal ground
13	DO1-	Digital output 1 common
14	DI4	Digital input 4
15	DI5	Digital input 5
16	DI6	Digital input 6
18	A01+	Analogue signal (+output)
20	DO1+	Digital output 1

5.1.3 RELAY TERMINALS

Table 32. I/O terminal signals for relays and connection example.

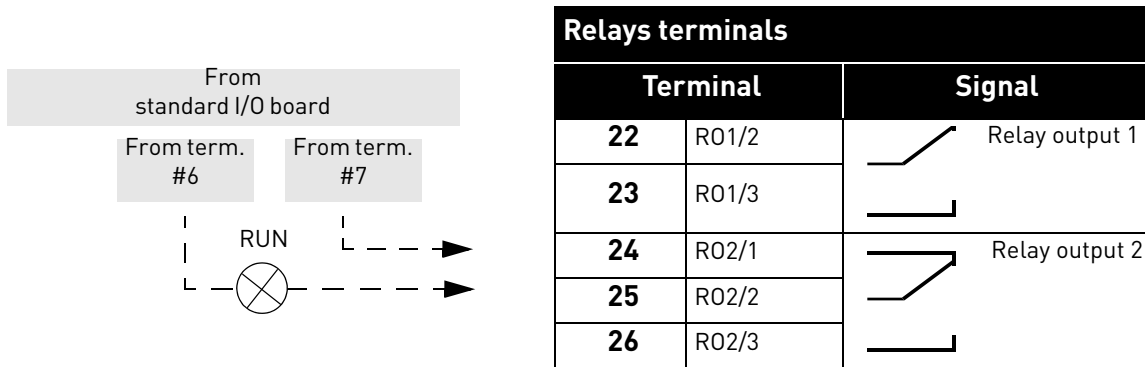

5.1.4 SAFE TORQUE OFF (STO) TERMINALS

For more information on the functionalities of the Safe Torque Off (STO), see chapter 9. This function is available only in the three-phase version.

Table 33. I/O terminal signals for the STO functions.

Safe Torque Off terminals	
Terminal	Signal
S1	Isolated digital input 1 (inter-changeable polarity); +24V ±20% 10...15mA
G1	
S2	Isolated digital input 2 (inter-changeable polarity); +24V ±20% 10...15mA
G2	
F+	Isolated feedback (CAUTION! Polarity to be respected); +24V ±20%
F-	Isolated feedback (CAUTION! Polarity to be respected); GND

5.1.5 DESCRIPTION OF ADDITIONAL ECHO CONNECTORS

In this paragraph you will find the description of the additional echo connectors for the I/O terminals and for the HMI.

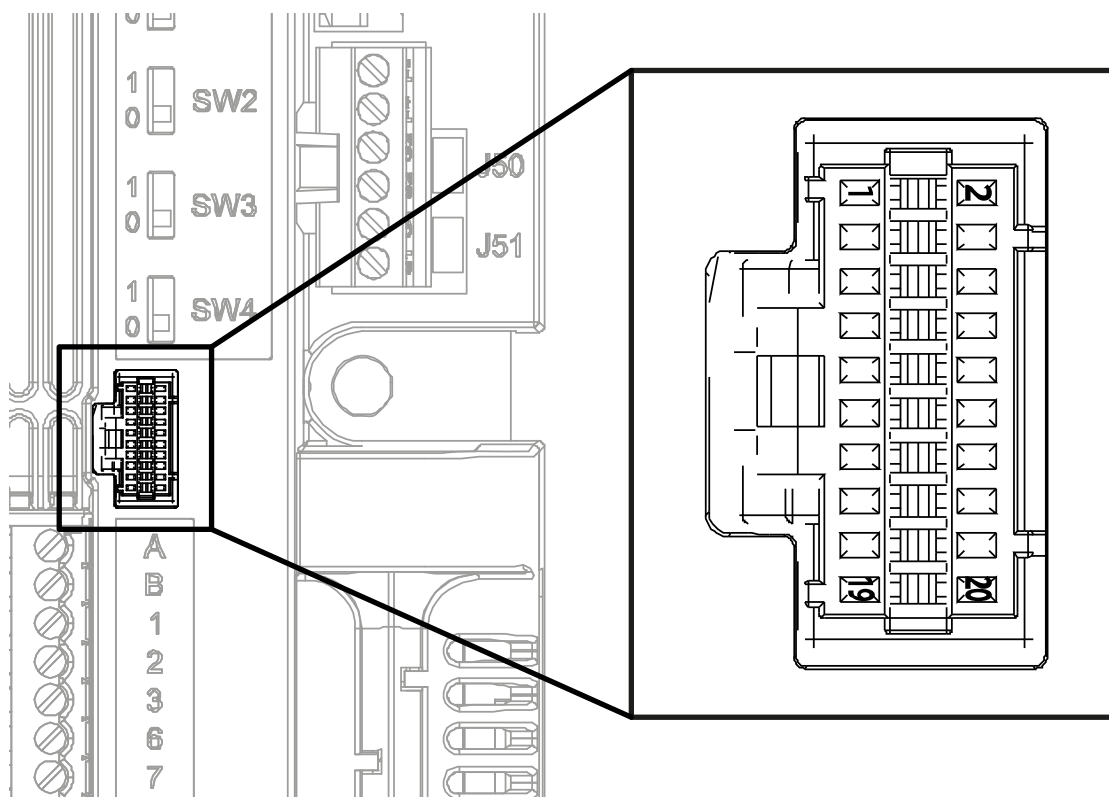

Figure 26. The I/O remote echo connector mounted on the control board.

In Figure 26 the view of Molex[®] connector for the I/O terminals is shown. In the control unit the position of this connector is numbered with 11 as shown in Figure 21 and Figure 23. The type of this connector is Pico-Clasp[™] Wire-to Board PCB Header, Dual Row, Right Angle. The code by Molex[®] is: 501571-2007.

It mates with Pico-Clasp[™] Wire-to Board Receptacle Housing (crimp housing), Dual Row, 20 Circuits. The code by Molex[®] is: 501189-2010. See Figure 27.

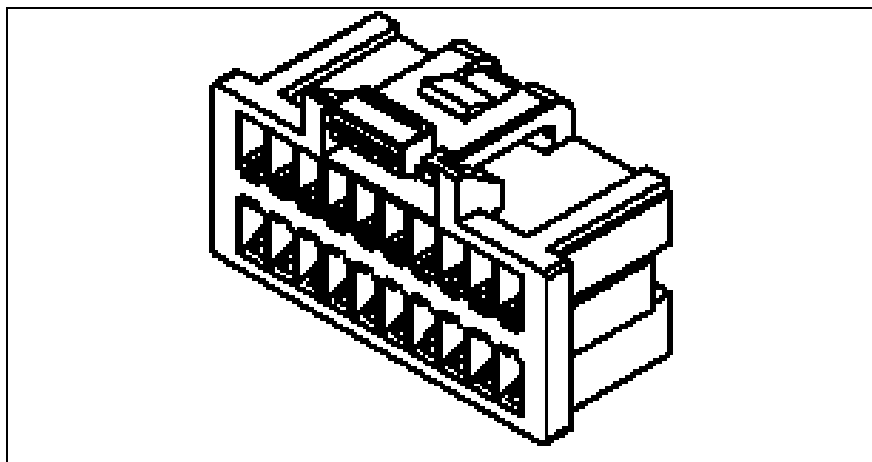

Figure 27. Receptacle housing for I/O remote echo connector.

To connect I/Os to the control unit through echo terminals this connector has to be used. In the following table, the correspondence between the pins of this connector and the VACON[®] 20 CP terminals is shown.

Pin number	Signal	Description
1	RS485_B	Serial bus, positive
2	DI2	Digital input 2
3	RS485_A	Serial bus, negative
4	DI3	Digital input 3
5	NC	not connected
6	AI2+	
7	NC	not connected
8	GND	
9	+10Vref	
10	DO1-	common for digital output 1
11	AI1+	
12	DI4	Digital input 4
13	GND	
14	DI5	Digital input 5
15	24Vout	
16	DI6	Digital input 6
17	DIN COM	
18	AO1+	Analogue output 1
19	DI1	Digital input 1
20	DO1+	Digital output 1

Table 34. I/O remote connector description.

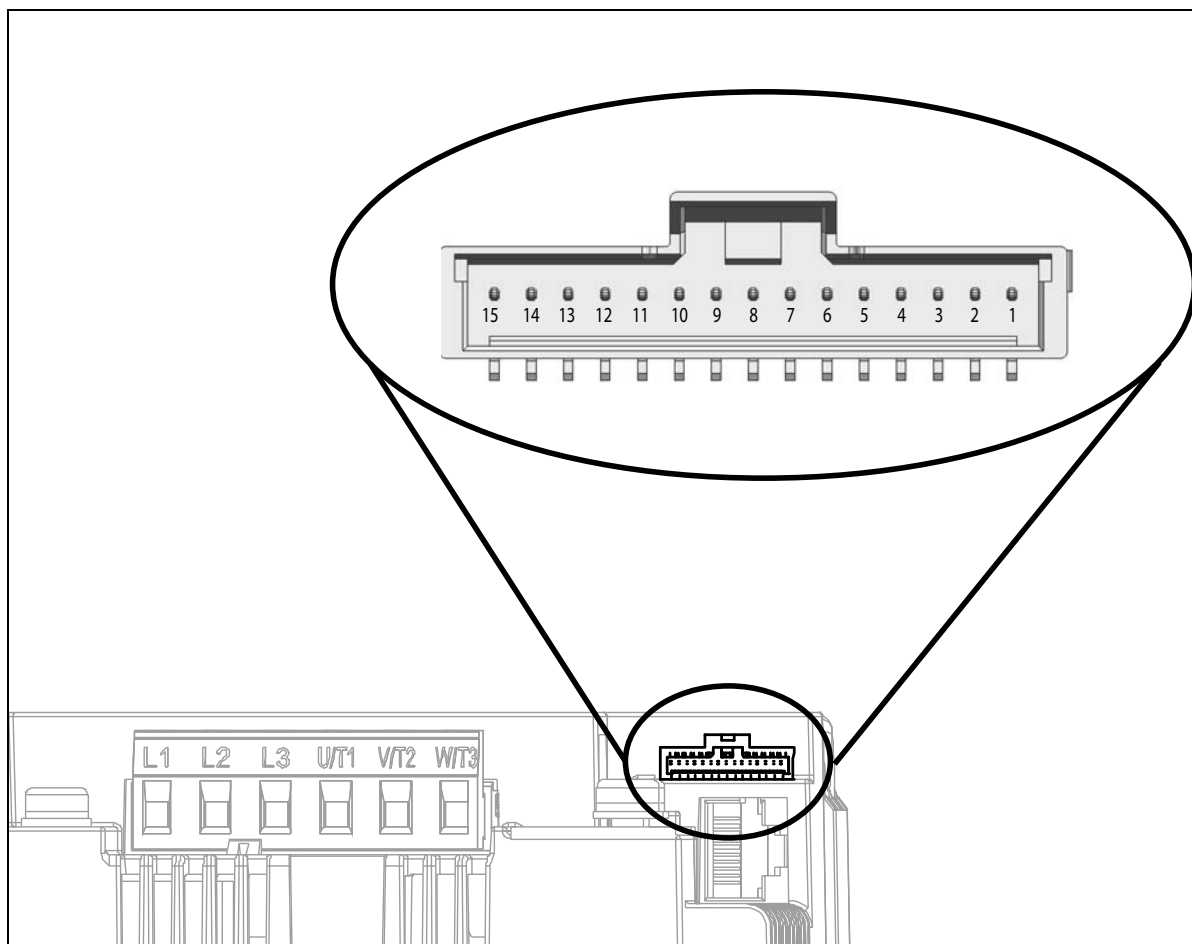

Figure 28. HMI remote connector.

In Figure 28 the view of Molex[®] connector for the HMI terminals is shown. In the control box the position of this connector is numbered with 8, as shown in Figure 21 and Figure 23. The type of connector is Pico-Clasp[™] Wire-to-Board Header, Surface Mount, Single Row, Vertical, with Positive Lock. The code by Molex[®] is: 501331-1507.

It mates with Pico-Clasp[™] Wire-to Board Female Housing (crimp housing), Single Row, with Positive lock, 15 Circuits. The code by Molex[®] is: 501330-1500.

To connect HMI to the control unit through echo terminals this connector has to be used. In the following table, the correspondence between the pins of this connector and the VACON[®] 20 CP HMI terminals is shown.

Pin number in RJ45 connector	Pin number of echo connector	Signal	Description
2	15	+24V	Panel supply
6	14	+3.3V	Panel supply
5	13	GND	ground

Table 35. HMI remote connector description with RJ45 correspondences.

Pin number in RJ45 connector	Pin number of echo connector	Signal	Description
1	12	Keyp_TX+	RS422 (connection for panel communication)
4	11	Keyp_TX-	
3	10	Keyp_RX+	
7	9	Keyp_RX-	
8	8	Led_CTRL1	Control signal for LED1
-	7	Led_CTRL2	Control signal for LED2
-	6	Led_CTRL3	Control signal for LED3
-	5	FAN+	External FAN+{+24V}
-	4	FAN-	GND for external FAN
-	3	nc	not connected
-	2	nc	not connected
-	1	nc	not connected

Table 35. HMI remote connector description with RJ45 correspondences.

5.1.6 LED HANDLING

As VACON® 20 Cold plate is often without the keypad, on the plastic cover of the drive there are 4 status LEDs. See the picture below.

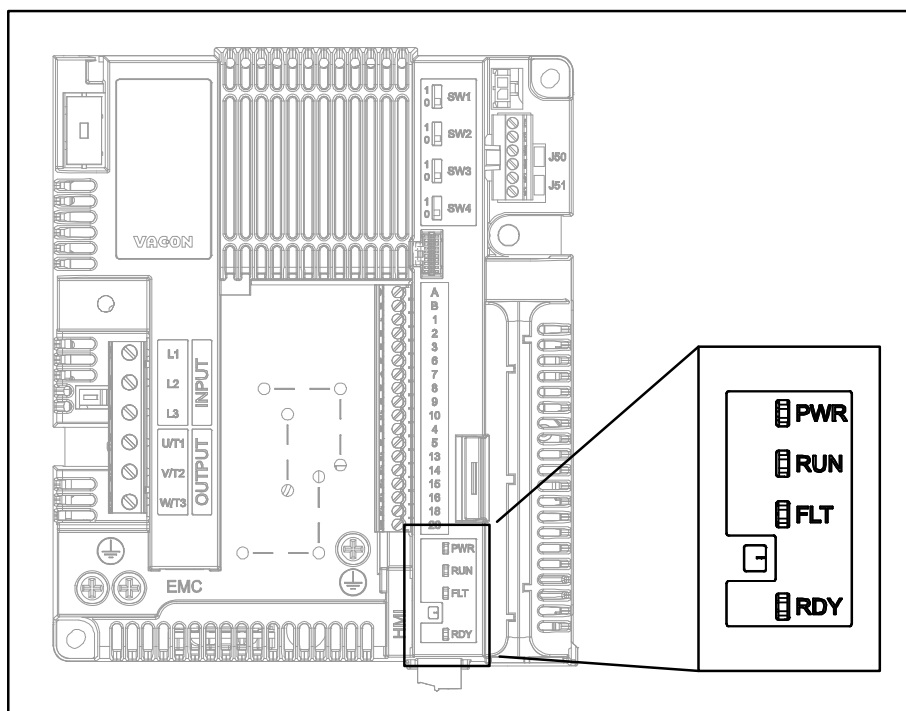

Figure 29. LED position on the MS2 cover.

Led "PWR" (orange led) means the drive is supplied by mains.

Led "RUN" (green led) means the drive is running.

Led "FLT" (red led) means the drive is experiencing a fault.

Led "RDY" (orange led) means the drive is ready and no fault is present. When a Warning is active, the led starts blinking.

5.1.7 SELECTION OF TERMINAL FUNCTIONS WITH DIP SWITCHES

VACON® 20 Cold Plate drive embodies four so-called *switches* that allow for two functional selections each. The shadowed terminals in Table 31 can be functionally modified with the dip switches.

The switches have two positions: 0 and 1. See Figure 30 to locate the switches and make appropriate selections for your requirements.

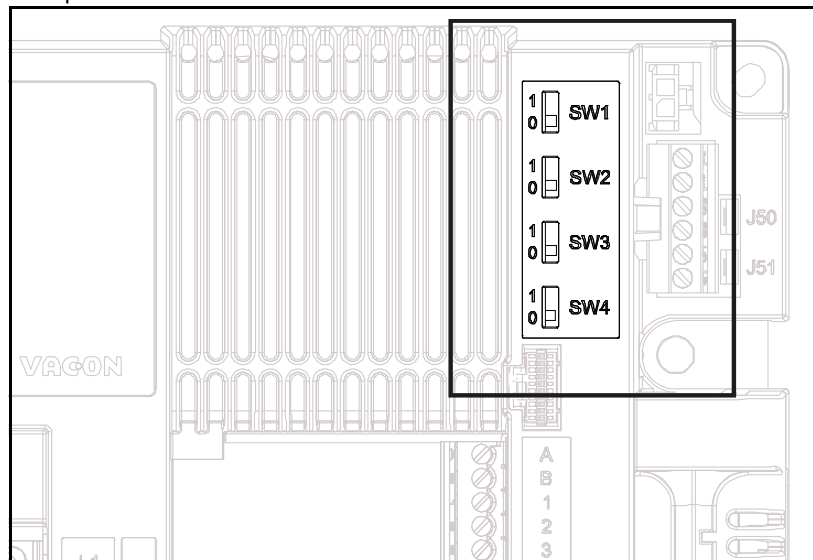

Figure 30. Dip switches

5.1.7.1 Switch SW1

The digital inputs (terminals 8-10 and 14-16) on the standard I/O board can be **isolated** from ground by setting the *dip switch SW1* to position '1'. See Figure 30. Locate the switch and set it in the desired position. The switch in the position "0" means that the common of digital input have been connected to the ground. The default position is "0".

5.1.7.2 Switches SW2 and SW3

Analogue inputs can be used as either current inputs or voltage inputs. The signal type is selected with two switches on the control board.

The switch SW2 is related to analogue input AI1. In position "1" the analogue input AI1 works in voltage mode. In position "0" the analogue input works in current mode. The default position for SW2 is "1".

The voltage range is 0...10V and the current is 0/4.....20 mA.

The switch SW3 is related to analogue input AI2. In the position "1" the analogue input AI2 works in voltage mode. In the position "0" the analogue input works in current mode. The default position for SW3 is "0".

The voltage range is 0...10V and the current is 0/4.....20 mA.

5.1.7.3 Switch SW4

The switch SW4 is related to the RS485 connection. It's used for bus termination. The bus termination must be set to the first and to the last device on the network. The switch SW4 in position "0" means that termination resistance is connected and the termination of the bus has been set. If the VACON® 20 CP is the last device on the net, this switch must be set to "0" position. The default position for SW4 is "0".

5.2 FIELDBUS CONNECTION

Modbus is a communication protocol developed by Modicon systems. In other words, it is a way of sending information between electronic devices. The device requesting the information is called the Modbus Master and the devices supplying information are Modbus Slaves. In a standard Modbus network, there is one Master and up to 247 Slaves, each with a unique Slave Address from 1 to 247. The Master can also write information to the Slaves. Modbus is typically used to transmit signals from instrumentation and control devices back to a main controller or data gathering system.

The Modbus communication interface is built around messages. The format of these Modbus messages is independent of the type of physical interface used. The same protocol can be used regardless of the connection type. Thanks to this, Modbus allows for the easy upgrade of the hardware structure of an industrial network, without the need for significant changes in the software. A device can also communicate with several Modbus nodes at once, although they are connected with different interface types, without the need to use a different protocol for every connection.

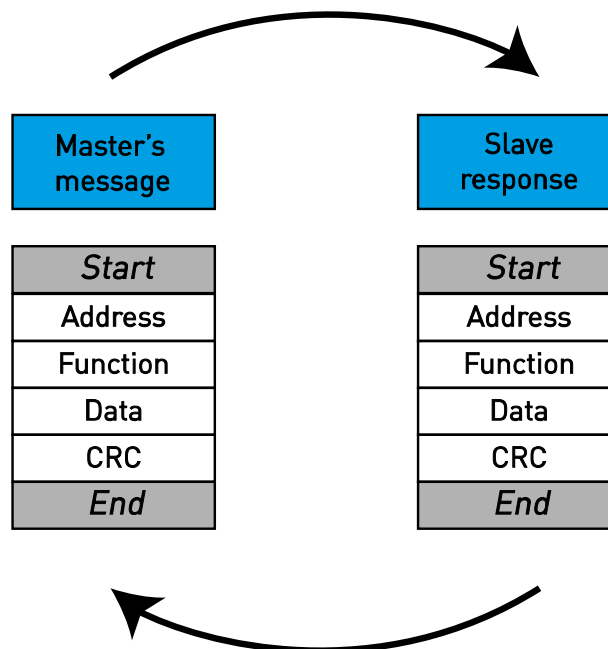

Figure 31. Basic structure of Modbus frame.

On simple interfaces such as RS485, the Modbus messages are sent in plain form over the network. In this case the network is dedicated to Modbus.

Each Modbus message has the same structure. Four basic elements are present in each message. The sequence of these elements is the same for all messages, to make it easy to parse the content of the Modbus message. A conversation is always started by a master in the Modbus network. A Modbus master sends a message and — depending on the contents of the message — a slave takes action and responds to it. There can be more masters in a Modbus network. The address in the message header is used to define which device should respond to a message. All other nodes on the Modbus network ignore the message if the address field doesn't match their own address.

5.2.1 MODBUS RTU PROTOCOL

Connections and communications	Interface	RS-485
	Data transfer method	RS-485 MS/TP, half-duplex
	Transfer cable	STP (shielded twisted pair), type Belden 9841 or similar
	Connector	2.5 mm ²
	Electrical isolation	Functional
	Modbus RTU	As described in "Modicon Modbus Protocol Reference Guide"
	Baud rate	300, 600, 1200, 2400, 4800, 9600, 19200, 38400 and 57600 baud
	Addresses	1 to 247

Table 36.

VACON® 20 CP drive is equipped with Modbus support as standard. The AC drive can be connected to fieldbus through RS485. The connection for RS485 is on the standard I/O (terminals A and B). See Figure 32.

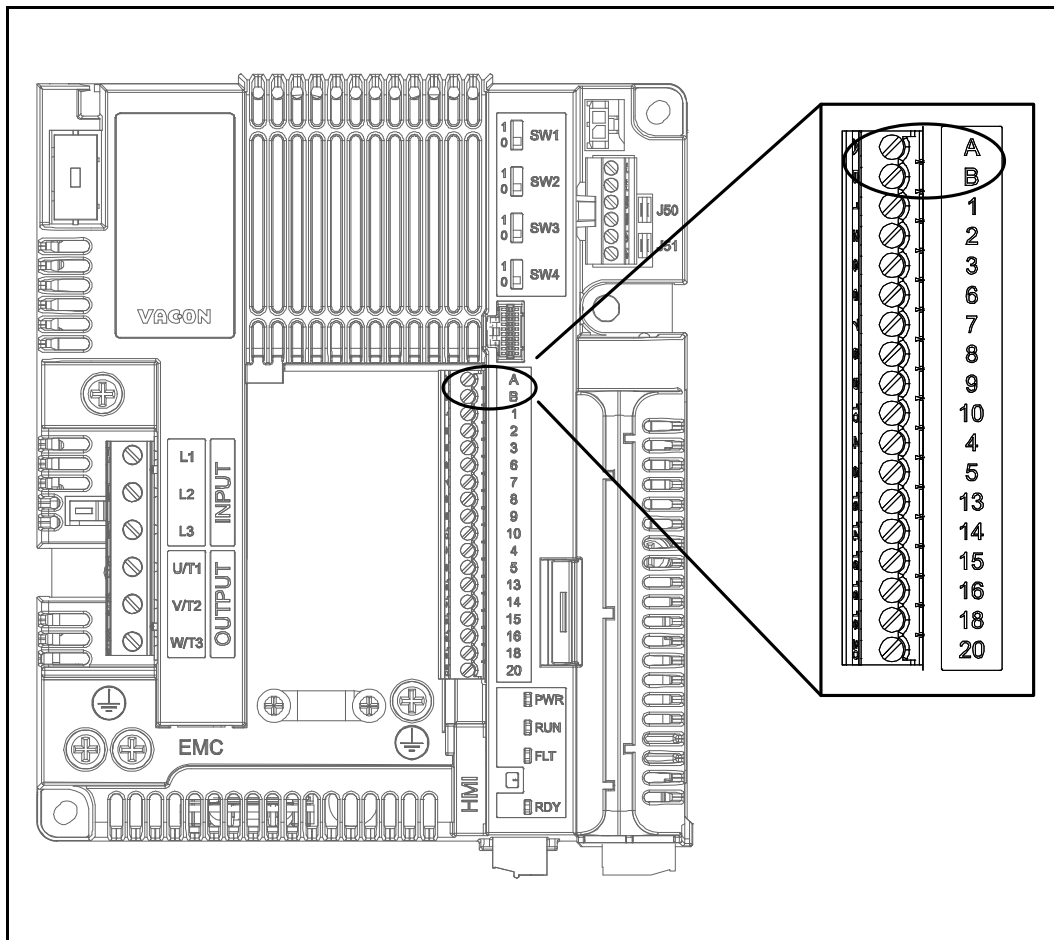
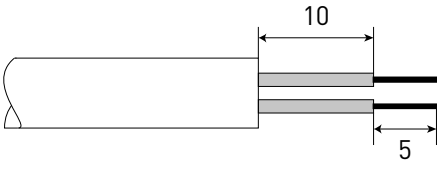
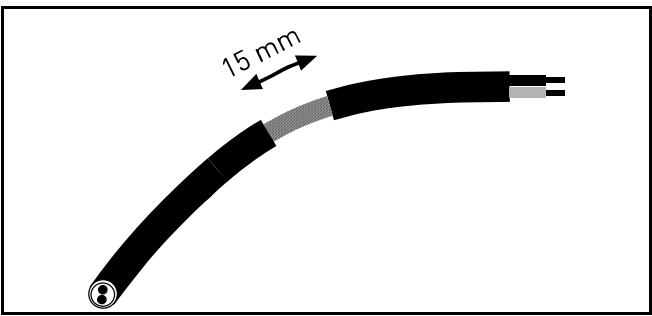
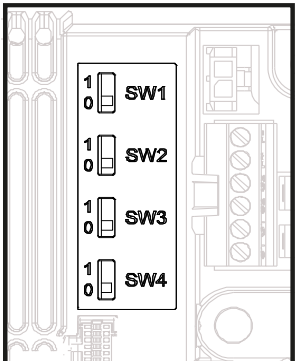

Figure 32. Position of the RS485 terminals on the I/O standard terminal connector.

5.2.2 PREPARATION FOR USE THROUGH RS485

<p>1</p>	<p>Strip about 15 mm of the RS485 cable (see specification on Table 36) and cut off the grey cable shield. Remember to do this for both bus cables (except for the last device).</p> <p>Leave no more than 10 mm of the cable outside the terminal block and strip the cables at about 5 mm to fit in the terminals. See picture below.</p>  <p>Also strip the cable now at such a distance from the terminal that you can fix it to the enclosure with the grounding clamp. Strip the cable at a maximum length of 15 mm. Do not strip the aluminium cable shield!</p> 
<p>2</p>	<p>Then connect the cable to its appropriate terminals on VACON® 20 CP AC drive standard terminal block, terminals A and B (A = negative, B = positive).</p>
<p>3</p>	<p>Using the cable clamp included in the supply of the drive, ground the shield of the RS485 cable to the enclosure of the AC drive.</p>
<p>4</p>	<p>If VACON® 20 Cold Plate drive is the last device on the bus, the bus termination must be set. Locate the switches to the right of the control terminals (see Figure 30) and turn the SW4 switch to position "0". Biasing is built in the termination resistor.</p> 
<p>5</p>	<p>NOTE: When planning the cable runs, remember to keep the distance between the fieldbus cable and the motor cable at a minimum of 30 cm.</p>
<p>6</p>	<p>The bus termination must be set for the first and the last device of the fieldbus line. We recommend that the first device terminated is the Master device.</p>

6. COMMISSIONING

Before commissioning, note the following directions and warnings:



Internal components and circuit boards of VACON[®] 20 CP drive (except for the galvanically isolated I/O terminals) are live when it is connected to mains potential. **Coming into contact with this voltage is extremely dangerous and may cause death or severe injury.**



The motor terminals **U, V, W** and the brake resistor terminals **are live** when VACON[®] 20 CP drive is connected to mains, **even if the motor is not running.**



The control I/O-terminals are isolated from the mains potential. However, the **relay outputs and other I/O-terminals may have a dangerous control voltage** present even when VACON[®] 20 CP drive is disconnected from mains.



Do not make any connections to or from the AC drive when it is connected to the mains.



After disconnecting the AC drive from the mains, **wait** until the indicators on the cover go out. Wait additional 30 seconds before doing any work on the connections of VACON[®] 20 CP drive. Do not open the unit before this time has expired. After expiration of this time, use a measuring equipment to absolutely ensure that no voltage is present. **Always ensure absence of voltage before starting any electrical work!**

6.1 COMMISSIONING OF THE DRIVE

Read carefully the safety instructions in Chapter 1 and above and follow them.

After the installation:

Table 37.

<input type="checkbox"/>	Check that both the AC drive and the motor are grounded.
<input type="checkbox"/>	Check that the mains and motor cables comply with the requirements given in chapter 4.
<input type="checkbox"/>	Check that the control cables are located as far as possible from the power cables, see chapter 4.4.
<input type="checkbox"/>	Check that the shields of the shielded cables are connected to protective earth marked with \oplus .
<input type="checkbox"/>	Check the tightening torques of all terminals.
<input type="checkbox"/>	Check that the wires do not touch the electrical components of the drive.
<input type="checkbox"/>	Check that the common inputs of digital input groups are connected to +24V or ground of the I/O terminal.
<input type="checkbox"/>	Check the quality and quantity of cooling air.
<input type="checkbox"/>	Check the inside of the AC drive for condensation.
<input type="checkbox"/>	Check that all Start/Stop switches connected to the I/O terminals are the in Stop-position.
<input type="checkbox"/>	Before connecting the AC drive to mains: Check mounting and condition of all fuses and other protective devices.

6.2 CHANGING EMC PROTECTION CLASS

If your supply network is an IT (impedance-grounded) system but your AC drive is EMC-protected according to class C1 or C2 you need to modify the EMC protection of the AC drive to EMC-level T (C4). This is done as described below:



Warning! Do not perform any modifications on the AC drive when it is connected to mains.

6.2.1 CHANGING EMC PROTECTION CLASS - MS2 THREE-PHASE VERSION

1

Remove the three screws on the EMC plate from the unit.

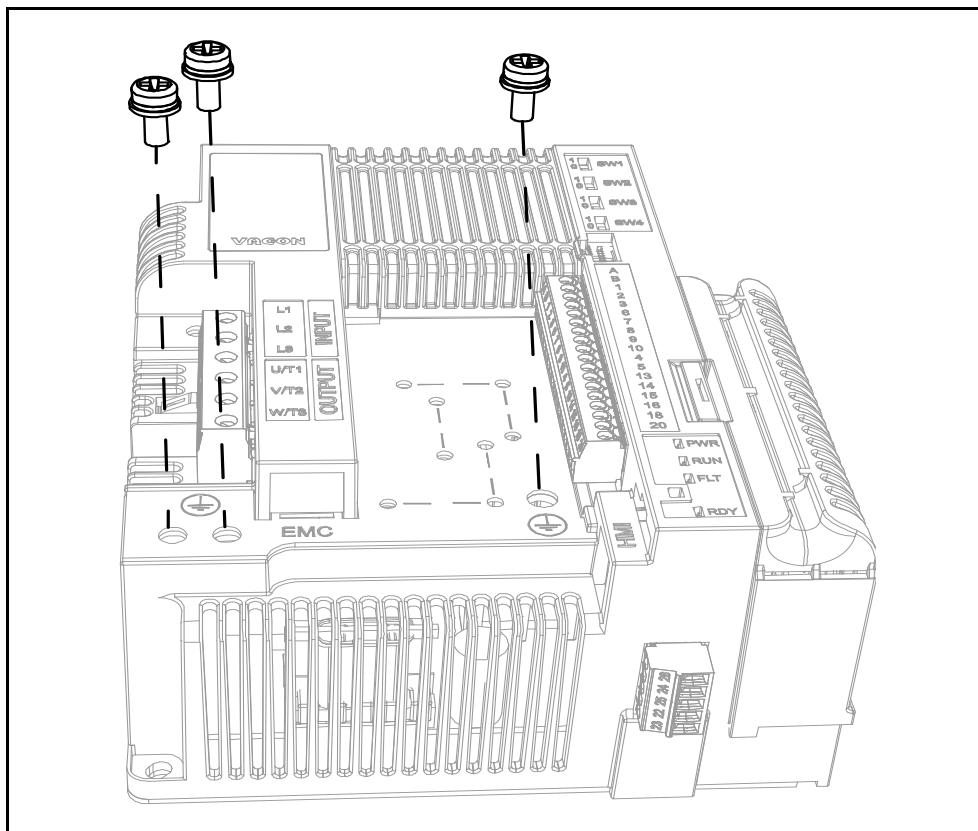

Figure 33. Changing of the EMC class in MS2 (three-phase version).

2 Remove the EMC plate from the unit. Then lift the plate with pliers to disconnect the EMC plate from the ground. See Figure 34.
Then reconnect the EMC plate to the unit.

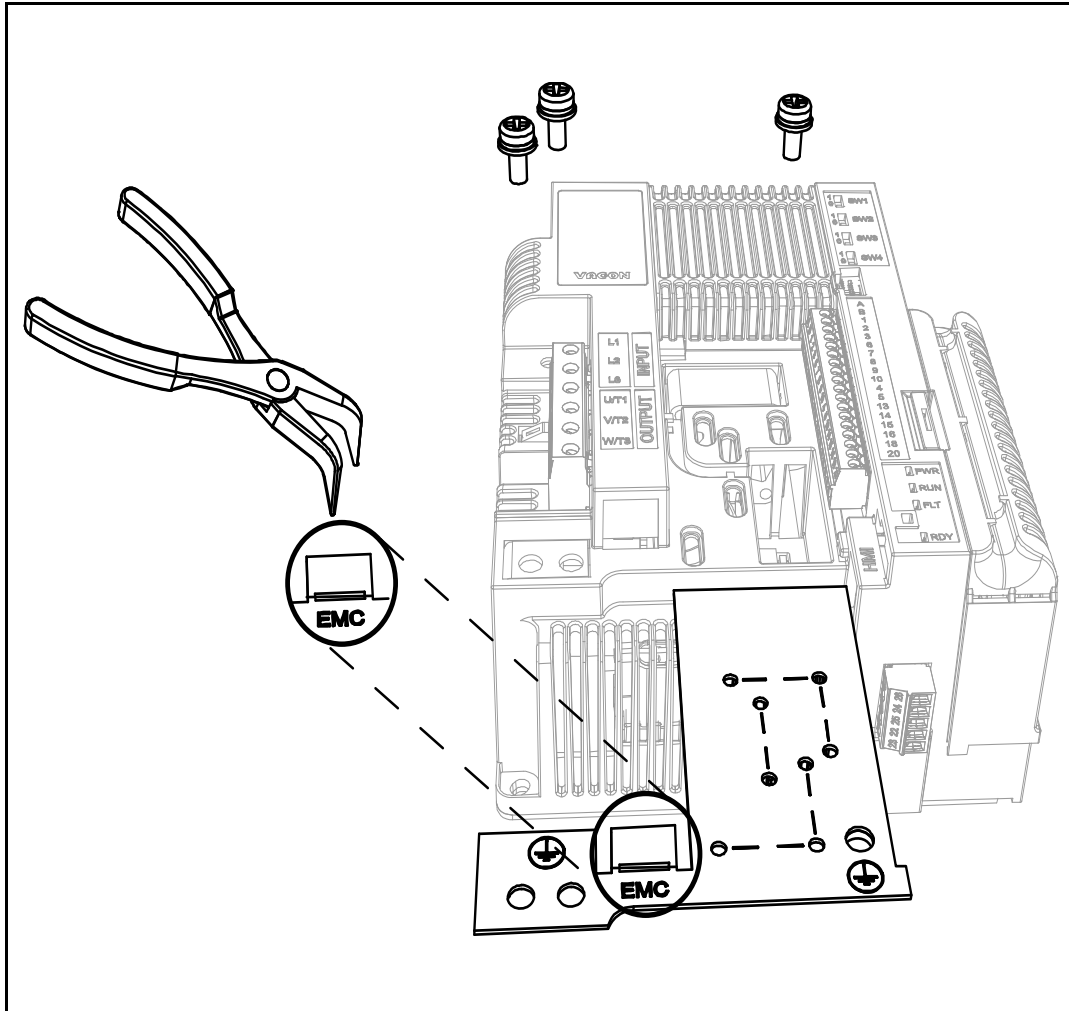

Figure 34. Changing of the EMC class in MS2 (three-phase version).

6.2.2 CHANGING EMC PROTECTION CLASS - MS2 SINGLE-PHASE VERSION

1 Remove the EMC screw as shown in the Figure 35.

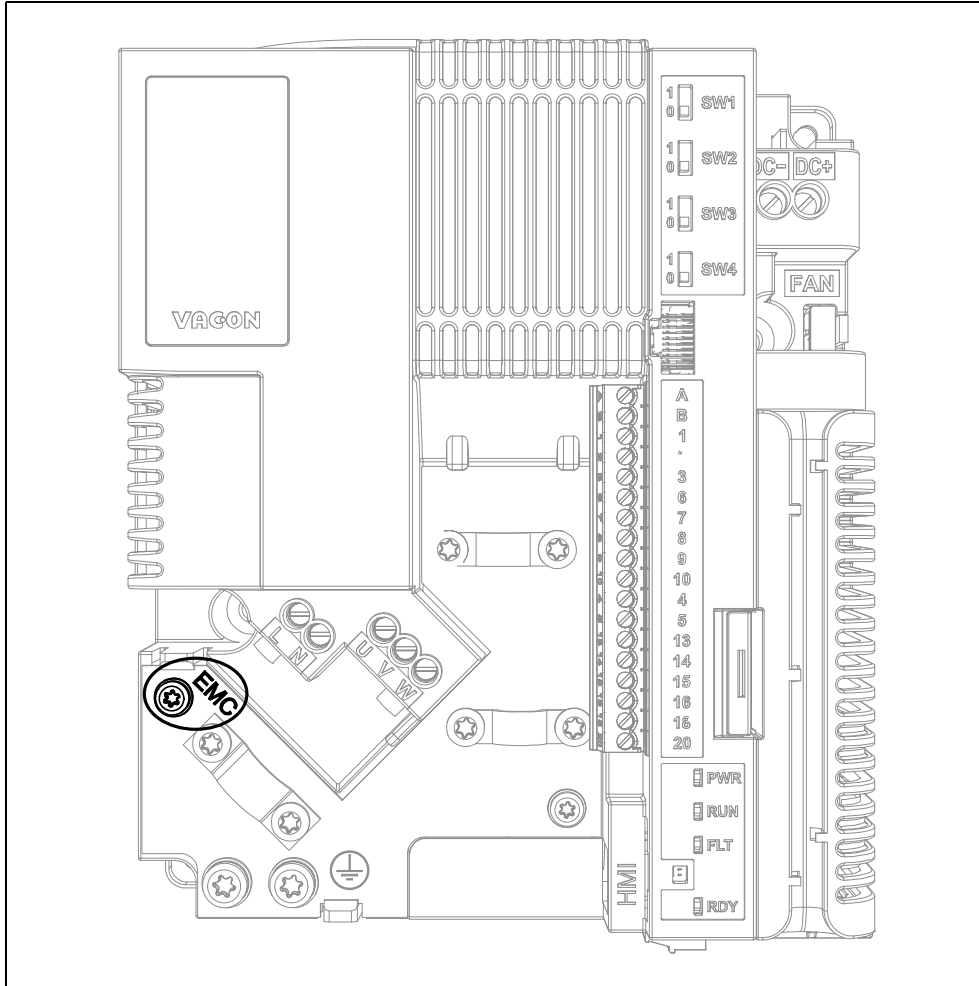

Figure 35. Changing the EMC class in the MS2 (single-phase version).

6.2.3 CHANGING EMC PROTECTION CLASS - MS3

1

Remove the EMC screw as shown in the Figure 36.

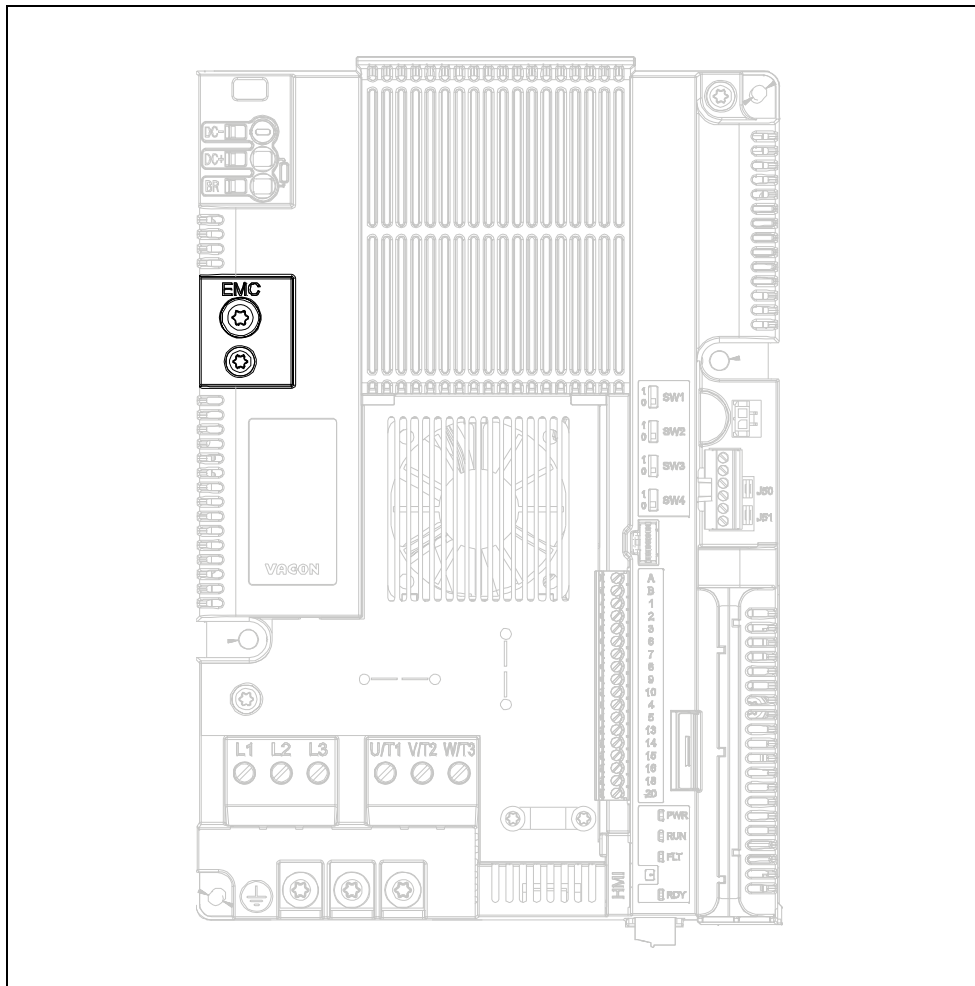

Figure 36. Changing the EMC class in the MS3.

CAUTION! Before connecting the AC drive to mains make sure that the EMC protection class settings of the drive are appropriately made.

6.3 RUNNING THE MOTOR

MOTOR RUN CHECK LIST



Before starting the motor, check that the motor is **mounted properly** and ensure that the machine connected to the motor allows the motor to be started.



Set the maximum motor speed (frequency) according to the motor and the machine connected to it.



Before reversing the motor make sure that this can be done safely.



Make sure that no power correction capacitors are connected to the motor cable.



Make sure that the motor terminals are not connected to mains potential.

6.3.1 CABLE AND MOTOR INSULATION CHECKS

1. Motor cable insulation checks

Disconnect the motor cable from terminals U, V and W of the AC drive and from the motor. Measure the insulation resistance of the motor cable between each phase conductor as well as between each phase conductor and the protective ground conductor. The insulation resistance must be $>1\text{M}\Omega$ at ambient temperature of 20°C .

2. Mains cable insulation checks

Disconnect the mains cable from terminals L1 (L), L2 (N) and L3 of the AC drive and from the mains. Measure the insulation resistance of the mains cable between each phase conductor as well as between each phase conductor and the protective ground conductor. The insulation resistance must be $>1\text{M}\Omega$ at ambient temperature of 20°C .

3. Motor insulation checks

Disconnect the motor cable from the motor and open the bridging connections in the motor connection box. Measure the insulation resistance of each motor winding. The measurement voltage must equal at least the motor nominal voltage but not exceed 1000 V. The insulation resistance must be $>1\text{M}\Omega$ at ambient temperature of 20°C .

6.4 MAINTENANCE

In normal conditions, the AC drive is maintenance-free. However, regular maintenance is recommended to ensure trouble-free operation and longevity of the drive. We recommend the table below is followed for maintenance intervals.

Table 38.

Maintenance interval	Maintenance action
Regularly and according to general maintenance interval	<ul style="list-style-type: none"> Check tightening torques of terminals
6...24 months (depending on environment)	<ul style="list-style-type: none"> Check input and output terminals and control I/O terminals. Check for corrosion on terminals and other surfaces Check door filter in case of cabinet installation
24 months	<ul style="list-style-type: none"> Clean heatsink
12...24 months	<ul style="list-style-type: none"> Charge capacitors, only after long storage times or long down times without supply: contact your nearest Danfoss service center

6.4.1 RECHARGING CAPACITORS IN STORED UNITS

When complete AC Drive units are stored without any voltage being applied to them, the recharging of the capacitors should be done at least every 12 months, by connecting the power supply to the unit and then keeping the unit powered up for a minimum of one hour.

If the storing time is much longer than one year, the recharging of the capacitors has to be done in a way that possible high leakage current through the capacitors is limited. The best alternative is to use a DC-power supply with an adjustable current limit. The current limit has to be set, for example, to 50...200mA and the DC-power supply has to be connected to the DC+/DC- terminals of the DC link.

Power up instruction for MS02 (three-phase) unit without DC+/DC- terminals:

- The DC supply is connected between the two input phases L1 and L2.
- The DC voltage has to be adjusted up to the nominal DC voltage level of the unit ($1.35 \times U_n$ AC) and has to be supplied for at least one hour.

If a DC voltage is not available and the unit has been stored much longer than one year de-energized, consult the manufacturer before connecting the power.

7. TECHNICAL DATA

7.1 AC DRIVE POWER RATINGS

7.1.1 MAINS VOLTAGE 3AC 208-240V

Table 39. Power ratings of VACON® 20 CP, supply voltage 3AC 208-240V.

3AC 208-240V							
	AC drive type	Input current [A]	Loadability			Motor shaft power	
			Rated continuous current I_N [A]	50% overload current [A]	Max current I_S	230V	230V
						[kW]	[HP]
MS2	0004	4.3	3.7	5.6	7.4	0.75	1.0
	0005	6.8	4.8	7.2	9.6	1.1	1.5
	0007	8.4	7.0	10.5	14.0	1.5	2.0
MS3	0011	13.4	11.0	16.5	22.0	2.2	3.0
	0012	14.2	12.5	18.8	25.0	3.0	4.0
	0017	20.6	17.5	26.3	35.0	4.0	5.0

NOTE: The rated currents in given ambient temperatures (in Table) are achieved only when the switching frequency is equal to or less than the factory default.

7.1.2 MAINS VOLTAGE 1AC 208-240V

Table 40. Power ratings of VACON® 20 CP, supply voltage 1AC 208-240V.

Mains Voltage 1AC 208-240V, 50/60 Hz							
	AC drive type	Input current [A]	Loadability			Motor shaft power	
			Rated continuous current I_N [A]	50% overload current [A]	Max current I_S	230V	230V
						[kW]	[HP]
MS2	0004	8.3	3.7	5.6	7.4	0.75	1.0
	0005	11.2	4.8	7.2	9.6	1.1	1.5
	0007	14.1	7.0	10.5	14.0	1.5	2.0

NOTE: The rated currents in given ambient temperatures (in Table) are achieved only when the switching frequency is equal to or less than the factory default.

7.1.3 MAINS VOLTAGE 3AC 380-480V

Mains Voltage 3AC 380-480V, 50/60 Hz							
	AC drive type	Input current [A]	Loadability			Motor shaft power	
			Rated continuous current I_N [A]	50% overload current [A]	Max current I_S	400V	480V
						[kW]	[HP]
MS2	0003	3.2	2.4	3.6	4.8	0.75	1.0
	0004	4.0	3.3	5.0	6.6	1.1	1.5
	0005	5.6	4.3	6.5	8.6	1.5	2.0
	0006	7.3	5.6	8.4	11.2	2.2	3.0
	0008	9.6	7.6	11.4	15.2	3.0	4.0
MS3	0009	11.5	9.0	13.5	18.0	4.0	5.0
	0012	14.9	12.0	18.0	24.0	5.5	7.5
	0016	20	16.0	24.0	32.0	7.5	10.0

Table 41. Power ratings of VACON® 20 CP, supply voltage 3AC 380-480V.

NOTE: The rated currents in given ambient temperatures (in Table 41) are achieved only when the switching frequency is equal to or less than the factory default.

7.1.4 DEFINITIONS OF OVERLOADABILITY

Overloadability =Following continuous operation at rated output current I_N , the AC drive supplies 150% * I_N for 1 min, followed by a period of at least 9 min at I_N or below.

Example: If the duty cycle requires 150% rated current for 1 min in every 10 min, the remaining 9 min must be at rated current I_N or less.

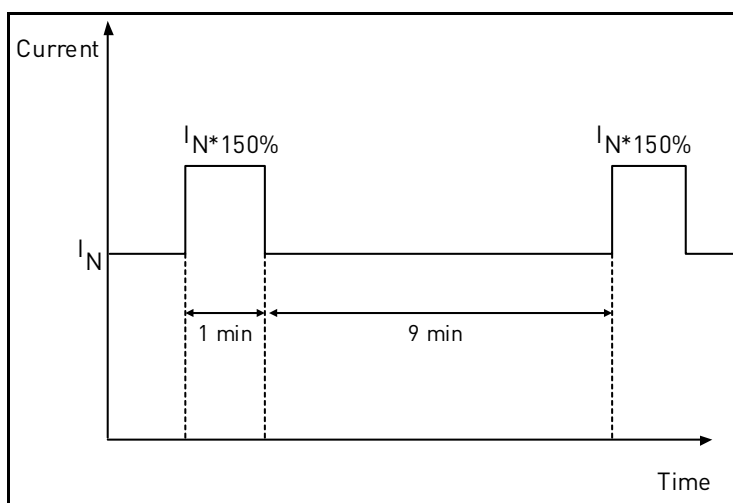

Figure 37. High overload.

7.2 BRAKE RESISTORS

7.2.1 INTERNAL BRAKE RESISTOR

Internal brake resistor is available with following plus code:

+DBIR (Dynamic Brake Internal Resistance)

Table 42. Internal brake resistor rating, 3AC 380-480V

Internal Brake Resistor	Technical data
MS2	1500 Ohm 460 W
MS3	not available

7.2.2 EXTERNAL BRAKE RESISTOR

Make sure that the resistance is higher than the minimum resistance defined. The power handling capacity must be sufficient for the application. Brake chopper is available only in three-phase version.

Recommended brake resistor values for VACON® 20 CP AC drives:

Mains Voltage 3AC 208-240 V, 50/60 Hz		
Enclosure	Type	Minimum Resistance recommended [Ohm]
MS2	0004	50
	0005	50
	0007	50
MS3	0011	25
	0012	25
	0017	25

Table 43. External brake resistor ratings, 3AC 208-240V.

Mains Voltage 3AC 380-480 V, 50/60 Hz		
Enclosure	Type	Minimum Resistance recommended [Ohm]
MS2	0003	100
	0004	100
	0005	100
	0006	100
	0008	100
MS3	0009	50
	0012	50
	0016	50

Table 44. External brake resistor ratings, 3AC 380-480V.

7.3 VACON® 20 CP - TECHNICAL DATA

Table 45. VACON® 20 Cold Plate technical data.

Mains connection	Input voltage U_{in}	3AC 208...240V 1AC 208...240V 3AC 380...480V
	Input voltage tolerance	-15%...+10% continuously
	Input frequency	50/60 Hz
	Input frequency tolerance	45...66 Hz
	Protection class	I
	Connection to mains	Once per minute or less
	Starting delay	4 s
	Supply network	IT and TN-networks (cannot be used with corner earthed networks)
	Short-circuit current	Maximum short-circuit current has to be <50kA
	DC connection	Available as standard in MS2 single-phase enclosures and MS3
Motor connection	Output voltage	0... U_{in}
	Rated output current	I_N : Enclosure temperature max. +70°C. See Chapter 7.1.
	Overload output current	1.5 x I_N (1 min/10 min)
	Starting current	I_S for 2 s every 20 s ($I_S = 2.0 * I_N$)
	Output frequency	0...320 Hz
	Frequency resolution	0.01 Hz
	Protection class	I
	Motor characteristics	AC squirrel cage motors Permanent magnet motors
	Cable type	Screened motor cable
	Cable maximum length	30 m
Control characteristics	Switching frequency	Programmable 2...16 kHz; Default 6 kHz. Automatic switching frequency derating in case of overheating
	Frequency reference: Analogue input Panel reference	Resolution $\pm 0.05\%$ (11-bit), accuracy $\pm 1\%$ Resolution 0.01 Hz
	Field weakening point	8...320 Hz
	Acceleration time	0.1...3000 sec
	Deceleration time	0.1...3000 sec
	Braking	Brake chopper standard in all three-phase enclosures. External brake resistor optional.
Control connections	See Chapter 5.	

Table 45. VACON® 20 Cold Plate technical data.

Communication interface	Fieldbus	Standard: Serial communication (RS485/Modbus); Optional: CANopen; Profibus DP, Lonworks, DeviceNet, Profinet IO, Ethernet IP, Modbus TCP, EtherCAT, AS-interface
	Status indicators	Drive status indicators (LED) on front side (POWER, RUN, FAULT, READY)
	Enclosure operating temperature	-10°C (no frost)...+70°C
	Storage temperature	-40°C...+85°C
	Relative humidity	0 to 95% R _H , non-condensing, non-corrosive, no dripping water
	Pollution degree	PD2
	Altitude	100% load capacity (no derating) up to 1,000m; derating 1% / 100m at 1,000...3,000m
Ambient conditions	Degree of protection	MS2 (three-phase version): IP00 MS2 (single-phase version): IP20 MS3: IP20
	Stationary vibration: Sinusoidal	MS2 (three-phase version): 3 Hz ≤ f ≤ 9Hz: 10mm 9 Hz ≤ f ≤ 200Hz: 3g [3M7 acc. to IEC 60721-3-3]
		MS2 (single-phase version) and MS3: 3 Hz ≤ f ≤ 8.43 Hz: 7.5 mm 8.43 Hz ≤ f ≤ 200 Hz: 2g [3M6 acc. to IEC 60721-3-3]
	Shock/Bump:	MS2 (three-phase version): 25g / 6 ms [3M7 acc. to IEC 60721-3-3]
		MS2 (single-phase version) and MS3: 25g / 6 ms [3M6 acc. to IEC 60721-3-3]
EMC	2004/108/EC	
Directives	Low Voltage	2006/95/EC
	RoHS	2002/95/EC
	WEEE	2012/19/EC

Table 45. VACON® 20 Cold Plate technical data.

Standards	Immunity	EN61800-3: 2004 + A1: 2011, 1 st and 2 nd environment	
	Emissions	3-phase version	Category C2 as standard for conducted and radiated emissions
		1-phase version	Category C1 as standard for conducted emissions
			Category C2 as standard for radiated emissions. It can be C1 with a suitable enclosure and cabling.
		The drive can be modified to category C4.	
Production quality	Safety	EN 61800-5-1	
	ISO 9001		
Approvals	Functional Safety	TÜV - Tested	
	Electrical Safety	TÜV - Tested	
	EMC	TÜV - Tested	
Declaration of Conformity	USA, Canada	cURus approval, file number E171278	
	Korea	KC mark	
	Australia	RCM Declaration of Conformity	
	Europe	EC Declaration of Conformity	
Protections	Undervoltage trip limit	Depends on supply voltage (0.8775*supply voltage): Supply voltage 400 V: Trip limit 351 V Supply voltage 480 V: Trip limit 421 V Supply voltage 240 V: Trip limit 211 V	
	Earth fault protection	Yes	
	Mains supervision	Yes	
	Motor phase supervision	Yes (not available in 1-phase version)	
	Overcurrent protection	Yes	
	Unit overtemperature protection	Yes	
	Motor overload protection	Yes	
	Motor stall protection	Yes	
	Motor underload protection	Yes	
	Short-circuit protection of +24V and +10V reference voltages	Yes	
	Thermal motor protection	Yes (by PTC with option card)	

7.3.1 TECHNICAL INFORMATION ON CONTROL CONNECTIONS

Table 46. Technical information on standard I/O terminals.

Standard I/O terminals		
Terminal	Signal	Technical information
A	RS485	Differential receiver/transmitter Set bus termination with dip switches (see Chapter 5)
B	RS485	
1	Reference output	+10V, $\pm 5\%$; Maximum current 10 mA
2	Analogue input, voltage or current	Analogue input channel 1 0- +10V ($R_i = 200 \text{ k}\Omega$) 0/4-20 mA ($R_i = 250 \Omega$) Resolution 0.05 %, accuracy ± 1 % Selection V/mA with dip-switches (see Chapter 5). Default 0- +10V
3	I/O ground	Ground for reference and controls (connected internally to enclosure earth through $2\text{M}\Omega$)
6	24V aux. voltage	+24V, $\pm 10\%$, max volt. ripple < 100mVrms; max. 100 mA Short-circuit protected Can be used with an external power supply (with a current limiter or fuse protected) to supply the control unit and fieldbus for backup purposes. Dimensioning: max. 1000mA/control unit.
7	DIN COM	Common for digital inputs. Connected to GND with dip-switch SW1. See Chapter 5
8	Digital input 1	Positive or negative logic $R_i = \text{min. } 4\text{k}\Omega$ 15...30V = "1" 0...5V = "0"
9	Digital input 2	
10	Digital input 3	
4	Analogue input, voltage or current	Analogue input channel 2 0- +10V ($R_i = 200 \text{ k}\Omega$) 0/4-20 mA ($R_i = 250 \Omega$) Resolution 0.05%, accuracy ± 1 % Selection V/mA with dip-switches (see Chapter 5). Default 0/4-20 mA
5	I/O ground	Ground for reference and controls (connected internally to enclosure earth through $2\text{M}\Omega$)
13	Digital output common	Common for digital output 1 (DO1-)
14	Digital input 4	Positive or negative logic $R_i = \text{min. } 4\text{k}\Omega$ 15...30V = "1" 0...5V = "0"
15	Digital input 5	
16	Digital input 6	
18	Analogue signal (+output)	Analogue output channel 1, 0-10V (30mA max) Resolution 0.1%, accuracy ± 2.5 % Short-circuited protected.
20	Digital Output 1	Open Collector max 35V / 50mA (DO1+)

Table 47. Technical information on relays.

Relay terminals		
Terminal	Signal	Technical information
22	Relay output 1*	Switching capacity 250VAC/3A (only earthed network allowed)
23		
24	Relay output 2*	Switching capacity NO 250VAC/5A NC 250VAC/3A (only earthed network allowed)
25		
26		

* If 230VAC is used as control voltage from the output relays, the control circuitry must be powered with a separate isolation transformer to limit short circuit current and overvoltage spikes. This is to prevent welding on the relay contacts. Refer to standard EN 60204-1, section 7.2.9

8. OPTIONS

8.1 VACON® KEYPAD WITH SEVEN-SEGMENT DISPLAY

The text keypad is an option available for VACON® 20 CP. The control keypad is the interface between the VACON® 20 CP AC drive and the user.

Main Switch only for AC voltage. Do not use for DC voltage.

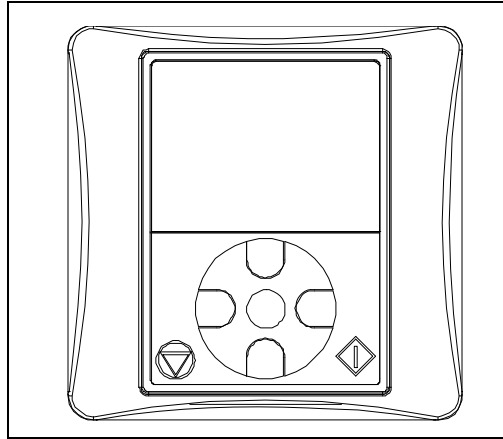

Figure 38. Text keypad.

Order code	Description	Type of option
VACON-PAN-HMTX-MC06-CP	Handheld/Magnetic fixing IP66 text keypad w/ cable, l=1m/39.37 inches	Loose option

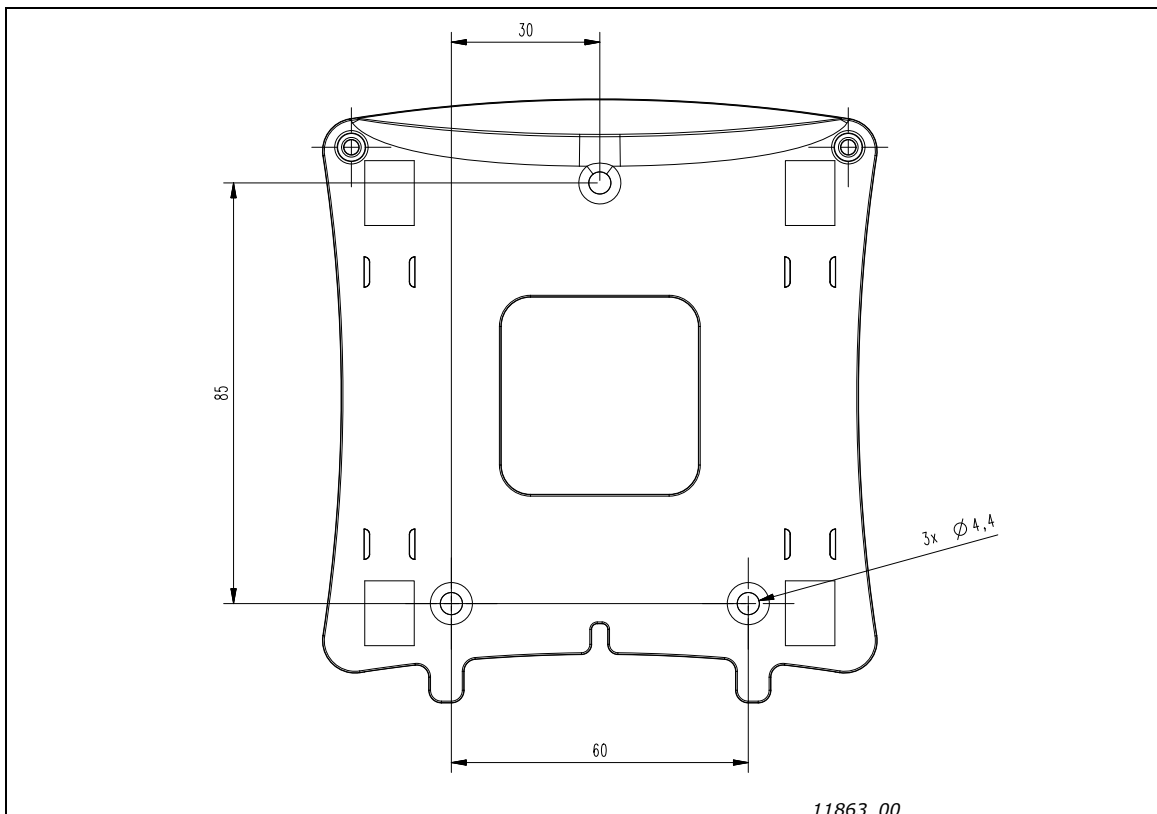

Figure 39. Display holder dimensions for wall-mounting

With the keypad it is possible to control the speed of the motor, to supervise the state of the drive and to set the AC drive's parameters. The button section of the text keypad is shown in the following picture.

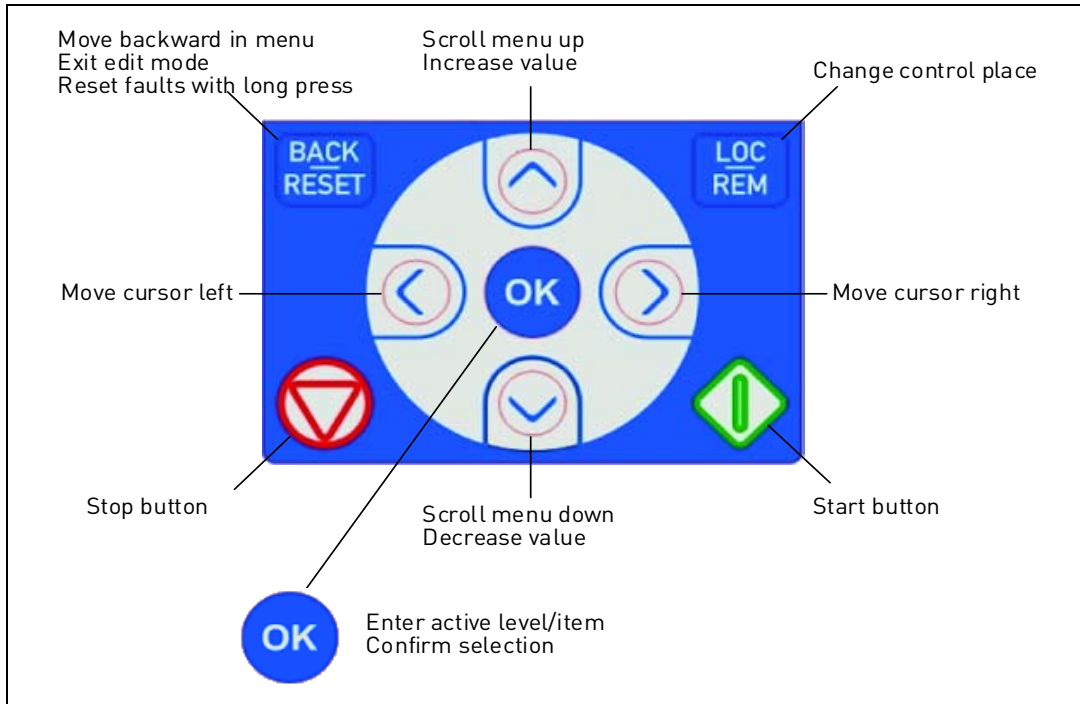

Figure 40. Keypad buttons.

8.2 TEXT KEYPAD

The keypad display indicates the status of the motor and the drive and any irregularities in motor or drive functions. On the display, the user can see the information about his present location in the menu structure and the item displayed.

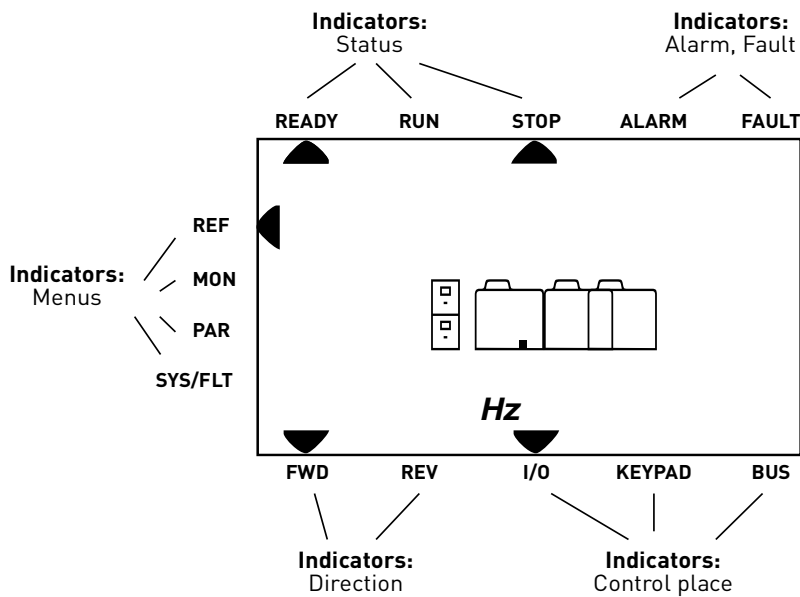

Figure 41. Keypad display.

8.3 MENU STRUCTURE

The data on the control keypad are arranged in menus. Use the Up and Down arrows to move between the menus. Enter the group/item by pressing the OK button and return to the former level by pressing the Back/Reset button. The arrows on the left of the display show the active menu. In Figure 41 the REF menu is active. The table below shows the structure of the main menu:

Reference (REF)	Reference from Keypad
Monitor (MON)	Monitoring values
Parameters (PAR)	Application parameters
System/Fault (SYS/FLT)	System Menu
	Active fault
	History fault

Table 48. Keypad menus.

8.4 USING THE KEYPAD

This chapter provides you with information on navigating the menus on VACON® 20 CP and editing the values of the parameters.

8.4.1 MAIN MENU

The menu structure of VACON® 20 CP control software consists of a main menu and several submenus. Navigation in the main menu is shown below:

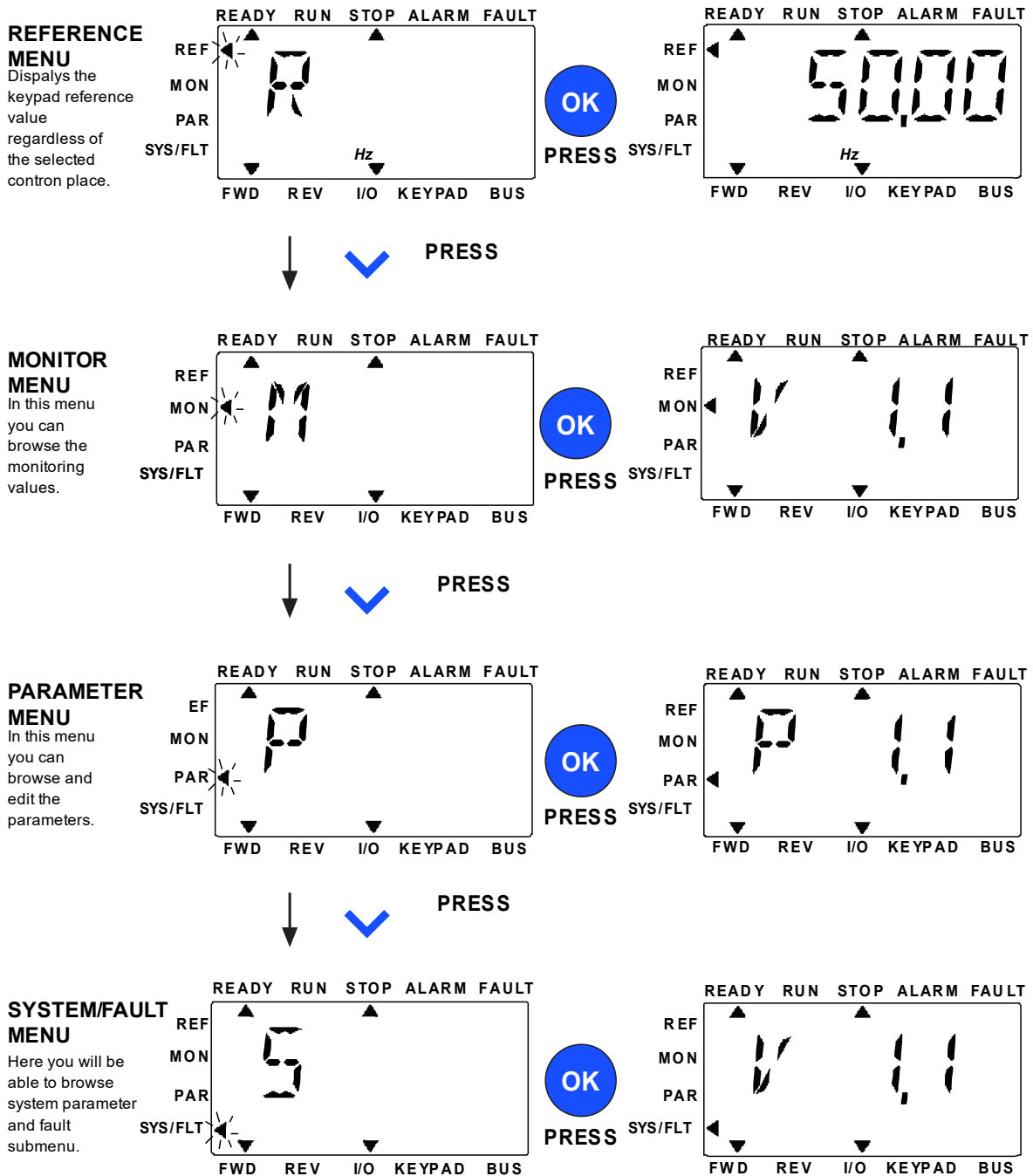

Figure 42. The Main menu of VACON® 20 CP.

8.4.2 RESETTING FAULT

When a fault appears and the drive stops examine the cause of the fault, perform the action advised in the Fault Tracing paragraph and reset the fault by pressing the RESET button.

8.4.3 LOCAL/REMOTE CONTROL BUTTON

The LOC/REM button is used for two functions: to quickly access the Control page and to easily change between the Local (Keypad) and Remote control places.

Control places

The *control place* is the source of control where the drive can be started and stopped. Every control place has its own parameter for selecting the frequency reference source. In the VACON® 20 CP drive, the *Local control place* is always the keypad. The *Remote control place* is determined by parameter (I/O or Fieldbus). The selected control place can be seen on the status bar of the keypad.

Remote control place

I/O and Fieldbus can be used as remote control places.

Local control

Keypad is always used as control place while in local control. Local control has higher priority than remote control. Switching between Local and Remote Control can be done by pressing the LOC/REM-button on the keypad.

8.4.4 REFERENCE MENU

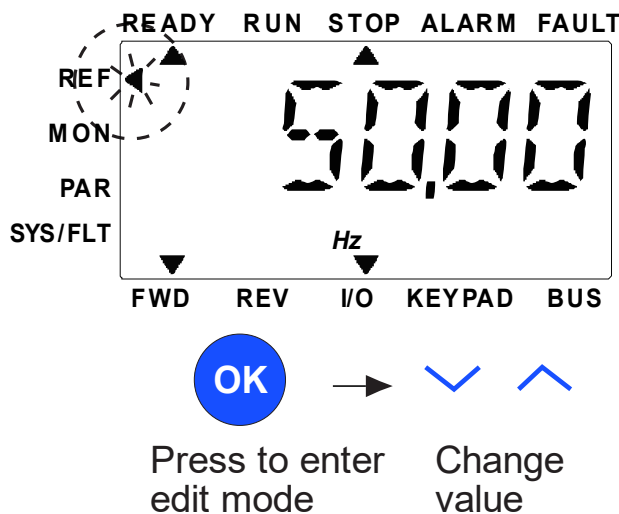

Figure 43. Reference menu.

Move to the reference menu with the UP / DOWN button (see Figure 42). The reference value can be changed with UP / DOWN button as shown in Figure 43.

If the value has big change, first press Left and Right buttons to select the digit which has to be changed, then press Up button to increase and Down button to decreases the value in the selected digit. The changing reference frequency will be taken into use immediately without pressing OK.

NOTE! LEFT and RIGHT buttons can be used to change the direction in Ref menu in local control mode.

8.4.5 MONITORING MENU

Monitoring values are actual values of measured signals as well as status of some control settings. It is visible in VACON® 20 CP display, but it can not be edited. The monitoring values are listed in the Application Manual.

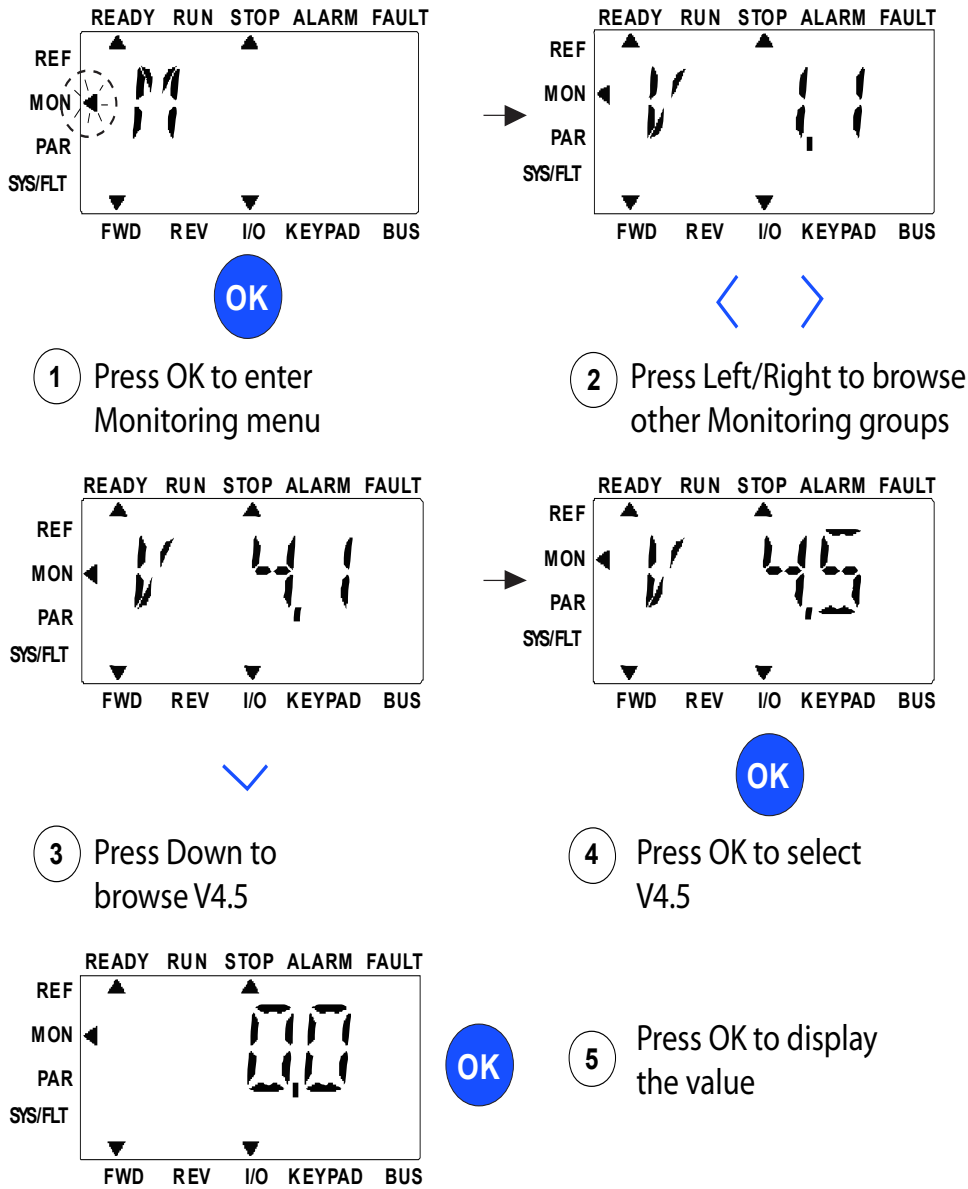

Figure 44. Monitoring menu.

Pressing Left/Right button to change the actual parameter to the first parameter of the next group, to browse monitor menu from V1.x to V2.1 to V3.1 to V4.1. After entering the desired group, the monitoring values can be browsed by pressing UP/DOWN button, as shown in Figure 44. In MON menu the selected signal and its value are alternating in the display by pressing OK button.

Note! Turn on drive power, arrowhead of main menu is at MON, V x.x or monitor parameter value of Vx.x is displayed in Panel. Display Vx.x or monitor parameter value of Vx.x is determined by the last show status before power shut down.

8.4.6 PARAMETER MENU

In Parameter menu only the Quick setup parameter list is shown as default. To view the other advanced parameter groups, see the Application Manual. The following figure shows the parameter menu view:

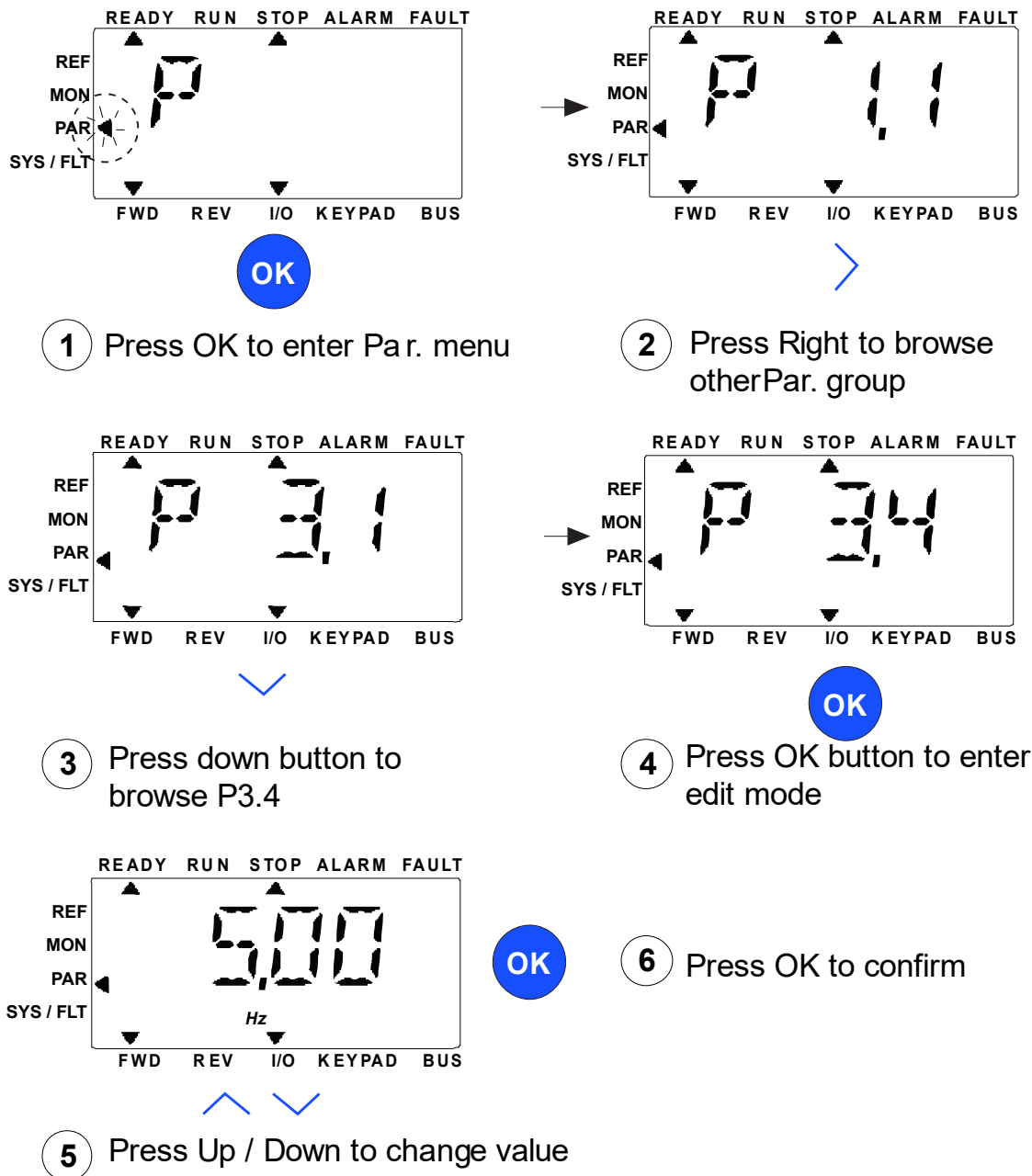

Figure 45. Parameter menu

Change value of a parameter following the procedure below:

1. Locate the parameter.
2. Enter the Edit mode by pressing OK.
3. Set new value with the arrow buttons up/down. You can also move from digit to digit with the arrow buttons left/right if the value is numerical and change then the value with the arrow buttons up/down.
4. Confirm change with OK button or ignore change by returning to previous level with Back/Reset button.

8.4.7 SYSTEM/FAULT MENU

SYS/FLT menu including fault submenu, field bus submenu and system parameter submenu. In system parameter submenu, there are some editable parameter (P) and some not editable parameters (V). The Fault submenu of SYS/FLT menu includes active fault submenu and fault history submenu.

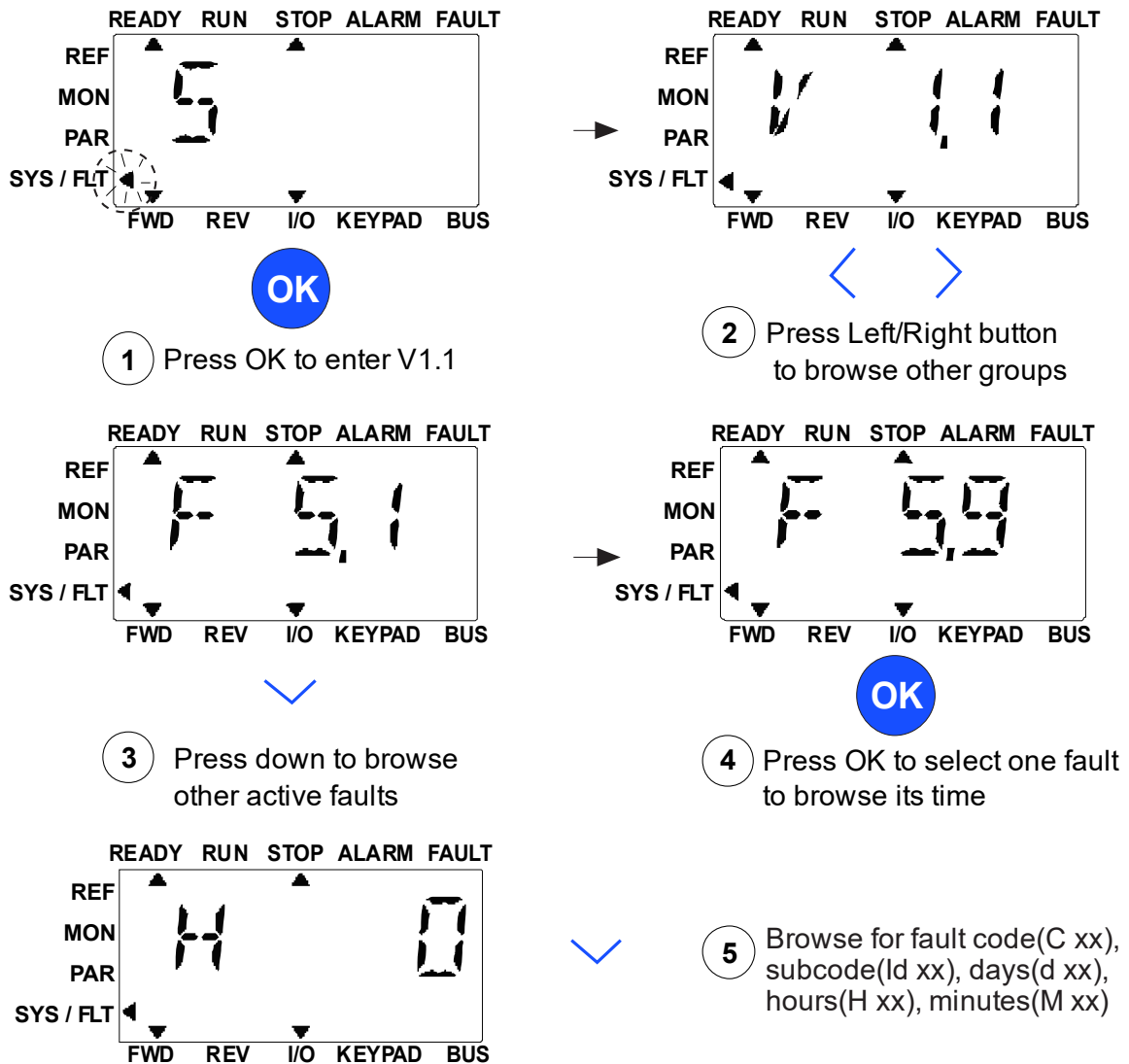

Figure 46. System and Fault menu.

8.4.7.1 Faults

Under this menu, you can find *Active faults*, *Reset faults*, *Fault history*, *Counters* and *Software info*.

In active fault situation, FAULT arrow is blinking and the display is blinking active fault menu item with fault code. If there are several active faults, you can check it by entering the active fault submenu F5.x. F5.1 is always the latest active fault code. The active faults can be reset by pressing BACK / RESET button with long time (>2 s), when the API is in active fault submenu level (F5.x). If the fault cannot be reset, the blinking continues. It is possible to select other display menus during active fault, but in this case the display returns automatically to the fault menu if no button is pressed in 10 seconds. The fault code, subcode and the operating day, hour and minute values at the fault instant are shown in the value menu (operating hours = displayed reading).

Active faults

Menu	Function	Note
Active faults	When a fault/faults appear(s), the display with the name of the fault starts to blink. Press OK to return to the Diagnostics menu. The <i>Active faults</i> submenu shows the number of faults. Select the fault and push OK to see the fault-time data.	The fault remains active until it is cleared with the RESET button or with a reset signal from the I/O terminal or fieldbus or by choosing <i>Reset faults</i> (see below). The memory of active faults can store the maximum of 10 faults in the order of appearance.

Fault history

Menu	Function	Note
Fault history	10 latest faults are stored in the Fault history.	Entering the Fault history and clicking OK on the selected fault shows the fault time data (details).

8.5 FAULT TRACING

Fault code	Fault name	Subcode	Possible cause	Remedy
1	Overcurrent		AC drive has detected too high a current ($>4 \cdot I_H$) in the motor cable: <ul style="list-style-type: none"> sudden heavy load increase short circuit in motor cables unsuitable motor 	Check loading. Check motor. Check cables and connections. Make identification run. Check ramp times.
2	Overvoltage		The DC-link voltage has exceeded the limits defined. <ul style="list-style-type: none"> too short a deceleration time brake chopper is disabled high overvoltage spikes in supply Start/Stop sequence too fast 	Make deceleration time longer. Use brake chopper or brake resistor (available as options). Activate overvoltage controller. Check input voltage.
3	Earth fault		Current measurement has detected that the sum of motor phase current is not zero. <ul style="list-style-type: none"> insulation failure in cables or motor 	Check motor cables and motor.
8	System Fault	84	MPI communication crc error	Reset the fault and restart. Should the fault re-occur, contact the distributor near to you.
		89	HMI receives buffer overflow	Check PC-drive cable. Try to reduce ambient noise
		90	Modbus receives buffer overflow	Check Modbus specifications for time-out. Check cable length. Reduce ambient noise. Check baudrate.
		93	Power identification error	Try to reduce ambient noise. Reset the fault and restart. Should the fault re-occur, contact the distributor near to you.
		97	MPI off line error	Reset the fault and restart. Should the fault re-occur, contact the distributor near to you.
		98	MPI driver error	Reset the fault and restart. Should the fault re-occur, contact the distributor near to you.
		99	Option board driver error	Check contact in option board slot Try to reduce ambient noise; Reset the fault and restart. Should the fault re-occur, contact the distributor near to you.
		100	Option board configuration error	Check contact in option board slot Try to reduce ambient noise; Should the fault re-occur, contact the distributor near to you.

Table 49. Fault codes and descriptions.

Fault code	Fault name	Subcode	Possible cause	Remedy
8	System Fault	101	Modbus buffer overflow	Check Modbus specifications for time-out. Check cable length. Reduce ambient noise. Check baudrate.
		104	Option board channel full	Check contacts in option board slot. Try to reduce ambient noise. Should the fault re-occur, contact the distributor near to you.
		105	Option board memory allocation fail	Check contacts in option board slot. Try to reduce ambient noise. Should the fault re-occur, contact the distributor near to you.
		106	Option board Object queue full	Check contacts in option board slot. Try to reduce ambient noise. Should the fault re-occur, contact the distributor near to you.
		107	Option board HMI queue full	Check contacts in option board slot. Try to reduce ambient noise. Should the fault re-occur, contact the distributor near to you.
		108	Option board SPI queue full	Check contacts in option board slot. Try to reduce ambient noise. Should the fault re-occur, contact the distributor near to you.
		111	Parameter copy error	Check if parameter set is compatible with drive. Do not remove Keypad until copy is finished.
		113	Frequency detective timer overflow	Check keypad contacts. Try to reduce ambient noise. Should the fault re-occur, contact the distributor near to you.
		114	PC control time out fault	Do not close VACON® Live when PC control is active. Check PC-Drive cable. Try to reduce ambient noise.
		115	DeviceProperty data format	Reset the fault and restart. Should the fault re-occur, contact the distributor near to you.
120	Task stack overflow	Reset the fault and restart. Should the fault re-occur, contact the distributor near to you.		

Table 49. Fault codes and descriptions.

Fault code	Fault name	Subcode	Possible cause	Remedy
9	Undervoltage		<p>DC-link voltage is under the voltage limits defined.</p> <ul style="list-style-type: none"> • most probable cause: too low a supply voltage • AC drive internal fault • defect input fuse • external charge switch not closed <p>NOTE! This fault is activated only if the drive is in Run state.</p>	<p>In case of temporary supply voltage break reset the fault and restart the AC drive. Check the supply voltage. If it is adequate, an internal failure has occurred.</p> <p>Contact the distributor near to you.</p>
10	Input phase		Input line phase is missing.	Check supply voltage, fuses and cable.
11	Output phase		Current measurement has detected that there is no current in one motor phase.	Check motor cables and motor.
13	AC drive undertemperature		Too low temperature measured in power unit's heatsink or board. Heatsink temperature is under - 10°C.	Check the ambient temperature.
14	AC drive overtemperature		Too high temperature measured in power unit's heatsink or board. Heatsink temperature is over 100°C.	<p>Check the correct amount and flow of cooling air.</p> <p>Check the heatsink for dust.</p> <p>Check the ambient temperature.</p> <p>Make sure that the switching frequency is not too high in relation to ambient temperature and motor load.</p>
15	Motor stalled		Motor is stalled.	<p>Check motor and load.</p> <p>Insufficient motor power, check motor stall protection parametrization.</p>
16	Motor overtemperature		Motor is overloaded.	<p>Decrease motor load.</p> <p>If no motor overload exists, check the temperature model parameters.</p>
17	Motor underload		Motor is under loaded	Check load. Check underload protection parametrization.
19	Power overload		Supervision for drive power	Drive power is to high: decrease load.
25	Watchdog		<p>Error in the microprocessor monitoring</p> <p>Malfunction</p> <p>Component fault</p>	<p>Reset the fault and restart.</p> <p>If the fault occurs again, please contact your nearest distributor.</p>
27	Back EMF		Protection of unit when starting with rotating motor	<p>Reset the fault and restart.</p> <p>Should the fault re-occur, contact the distributor near to you.</p>
30	STO fault		Safe torque off signal does not allow drive to be set as ready	<p>Reset the fault and restart.</p> <p>Should the fault re-occur, contact the distributor near to you.</p>

Table 49. Fault codes and descriptions.

Fault code	Fault name	Subcode	Possible cause	Remedy
35	Application error	0	Firmware Interface version between Application and Control not matching	Load a compatible application. Please contact your nearest distributor.
		1	Application software flash error	Reload Application
		2	Application header error	Load a compatible application. Please contact your nearest distributor.
41	IGBT temp		IGBT temperature (UnitTemperature + I2T) too high	Check loading. Check motor size. Make identification run.
50	4 mA fault (Analog input)		Selected signal range: 4...20 mA (see Application Manual) Current less than 4 mA Signal line broken detached The signal source is faulty	Check the analog input's current source and circuit.
51	External fault		Error message on digital input. The digital input was programmed as an input for external error messages. The input is active.	Check the programming and check the device indicated by the error message. Check the cabling for the respective device as well.
52	Keypad Communication fault		The connection between the control keypad and the AC drive is broken.	Check keypad connection and keypad cable.
53	Fieldbus communication fault		The data connection between the fieldbus master and fieldbus board is broken	Check installation and fieldbus master.
54	Fieldbus Interface error		Defective option board or slot	Check board and slot.
55	Wrong run command		Wrong run alarm and stop command	Run forward and backward are activated at the same time
56	Temperature		Temperature fault	Board OPTBH is installed and measured temperature is above (or below) the limit
57	Identification		Identification alarm	Motor identification has not been successfully completed
63	Quick Stop		Quick Stop activated	The drive has been stopped with Quick Stop digital input or Quick Stop command by fieldbus

Table 49. Fault codes and descriptions.

8.6 OPTION BOARDS

VACON® 20 CP drive family embodies a wide selection of expander boards with which the available I/O resources of VACON® 20 CP AC drive can be increased and its versatility improved.

There is one board slot (labelled D) on the VACON® 20 CP control unit. To locate the slot, see Chapter 5. Usually, when the AC drive is delivered from the factory, the control unit does not include any option board in the board slot.

The following option boards are supported:

Order Code	Description	Note
OPT-B1-V	Option board with six bidirectional terminals.	With jumper blocks it is possible to use each terminal as digital input or as digital output.
OPT-B2-V	I/O expander board with a thermistor input and two relay outputs.	
OPT-B4-V	I/O expander board with one galvanically isolated analogue input and two galvanically isolated analogue outputs (standard signals 0(4)...20mA).	
OPT-B5-V	I/O expander board with three relay outputs	
OPT-B9-V	I/O expander board with five 42...240 VAC digital inputs and one relay output.	
OPT-BF-V	I/O expander board with analogue output, digital output and relay output.	On the OPTBF board, there is one jumper block for selecting the analogue output mode (mA/V).
OPT-BH-V	Temperature measurement board with three individual channels.	Supported sensors: PT100, PT1000, NI1000, KTY84-130, KTY84-150, KTY84-131
OPT-BK-V	ASi option board	AS-interface option card
OPT-C4-V	Lonworks option board	Pluggable connector with screw terminals
OPT-E2-V	Modbus RTU and N2	screw terminals
OPT-E3-V	Profibus DP option board	Pluggable connector with screw terminals
OPT-E5-V	Profibus DP option board	9-pin Sub-D terminal
OPT-E6-V	CANopen option board	
OPT-E7-V	DeviceNet option board	
OPT-E8-V	OPTE8 Modbus RTU and N2	sub-D9 connector
OPT-E9-V	Dualport Ethernet option board	
OPT-EC-V	EtherCat option board	

Table 50. Option boards supported in VACON® 20 CP.

See the Option boards User's Manual to use and install the option boards.

8.6.1 OPTION BOARD INSTALLATION



NOTE! Do not add or replace option boards or fieldbus boards on an AC drive with the power switched on. This may damage the boards.

1

- Remove the option slot cover.

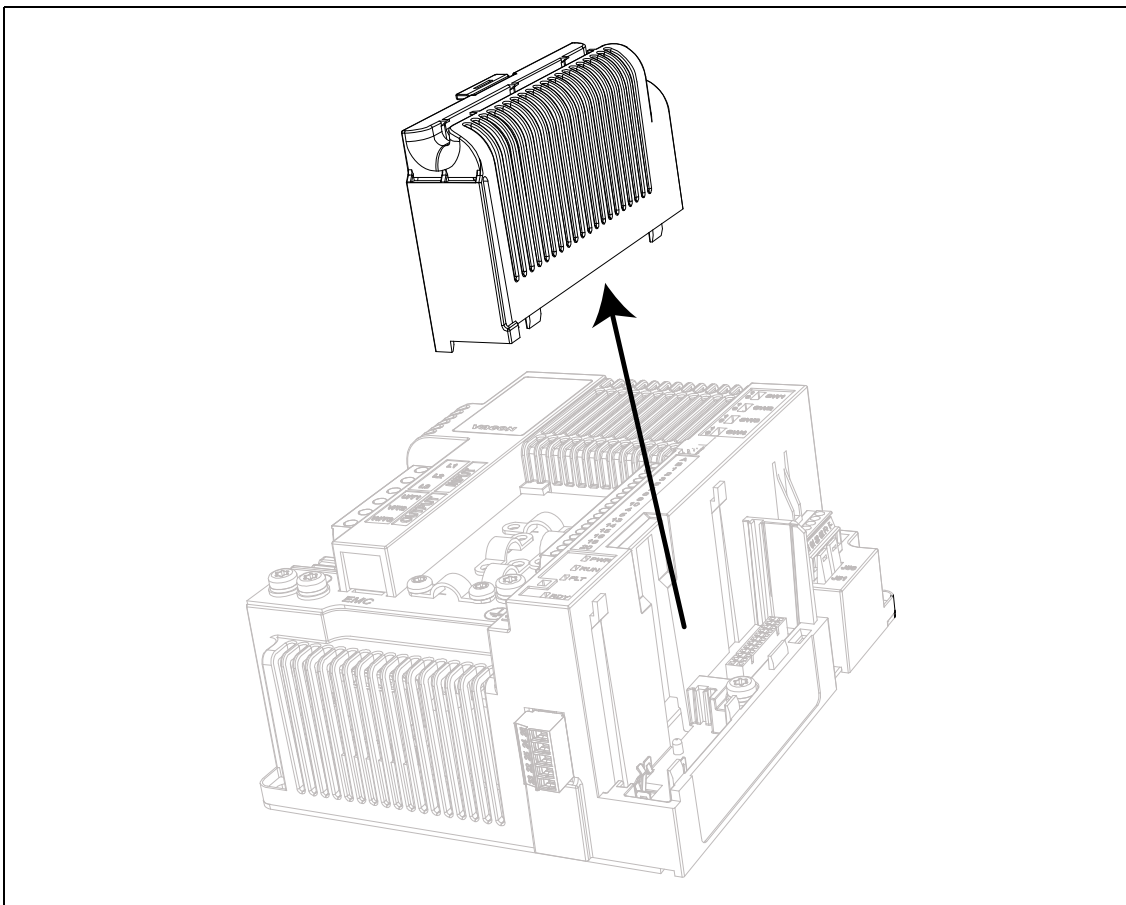

Figure 47. Opening the main cover, MS2 three-phase version example.



The relay outputs and other I/O-terminals may have a dangerous control voltage present even when the drive is disconnected from mains.

2

- Make sure that the sticker on the connector of the board says "dv" (dual voltage). This indicates that the board is compatible with VACON® 20 CP. See below:

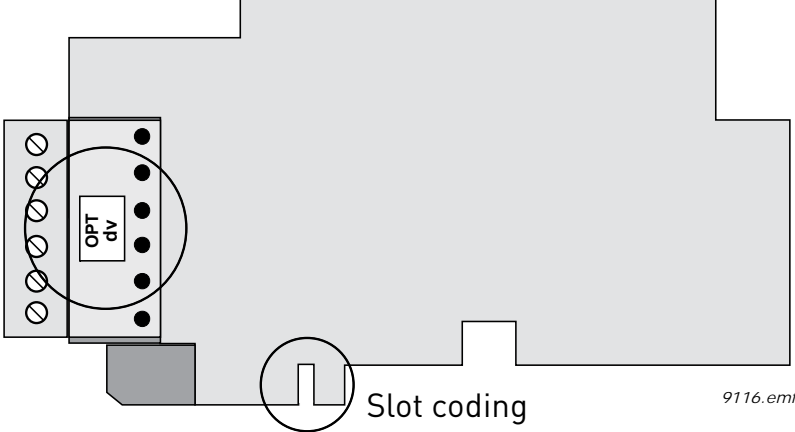

9116.emf

- NOTE:** Incompatible boards cannot be installed on VACON® 20 CP. Compatible boards have a slot coding that enables the placing of the board (see above)

3

- Install the option board into the slot as shown in the picture below.

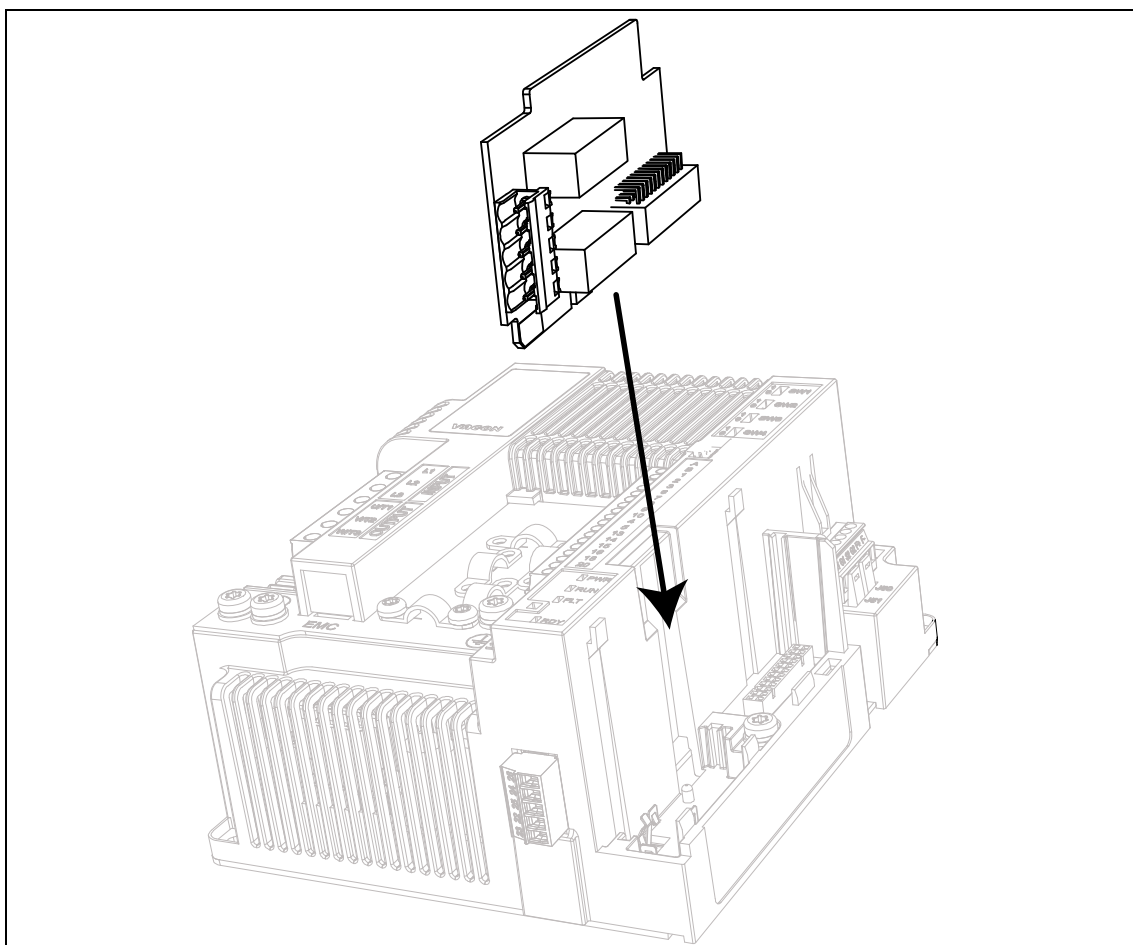

Figure 48. Option board installation.

4

- Mount the option slot cover.

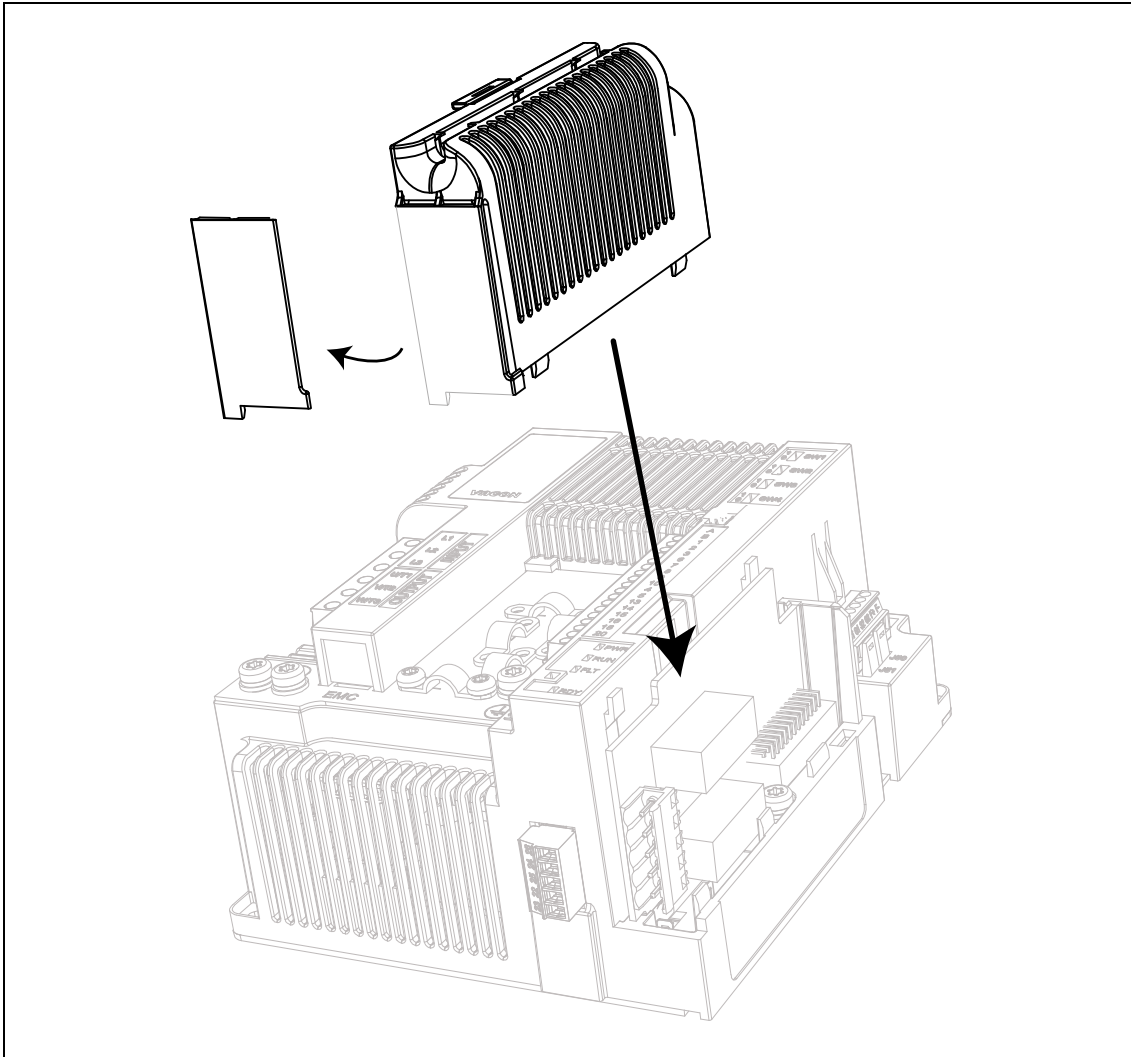

Figure 49. Mounting of the option slot cover: remove the plastic opening for the option board terminals.

9. SAFE TORQUE OFF









This chapter describes the Safe Torque Off (STO) function which is a functional safety feature present in VACON® 20 CP drive products as standard. This function is available only in the three-phase version.

9.1 GENERAL DESCRIPTION

The STO function brings the motor in no-torque-state as defined by 4.2.2.2 of the IEC 61800-5-2: *“Power that can cause rotation (or motion in the case of a linear motor) is not applied to the motor. The Power Drive System (Safety Related) will not provide energy to the motor which can generate torque (or force in the case of a linear motor).”*

Therefore, the STO function is suitable for applications that rely on the immediate removal of power to the actuator, resulting in an uncontrolled coast to stop (activated by an STO demand). **Additional protective measures need to be applied when an application requires a different stop method.**

9.2 WARNINGS

	Designing of safety-related systems requires specialist knowledge and skills. Only qualified people are permitted to install and set up the STO function. The use of STO does not itself ensure safety. An overall risk evaluation is required for ensuring that the commissioned system is safe. Safety devices must be correctly incorporated into the entire system which must be designed in compliance with all relevant standards within the field of industry.
	The information in this manual provides guidance on the use of the STO function. This information is in compliance with accepted practice and regulations at the time of writing. However, the end product/system designer is responsible for ensuring that the end-system is safe and in compliance with relevant regulations.
	When a permanent magnet motor is used and in case of a multiple IGBT power semiconductor failure, when the STO option energizes the drive outputs to the off state, the drive system may still provide an alignment torque which maximally rotates the motor shaft by $180^\circ/p$ (where p is the number of poles of the motor) before the torque production ceases.
	Electronic means and contactors are not adequate for protection against electric shock. The Safe Torque Off function does not disconnect the voltage or the mains from the drive. Therefore hazardous voltages may still be present on the motor. If electrical or maintenance work has to be carried out on electrical parts of the drive or the motor, the drive has to be completely isolated from the main supply, e.g. using an external supply disconnecting switch (see EN60204-1 section 5.3).
	This safety function corresponds to an uncontrolled stop in accordance with stop category 0 of IEC 60204-1. The STO function does not comply with Emergency Switching Off according to IEC 60204-1 (no galvanic insulation from the Mains in case the motor is stopped).
	The STO function is not a prevention of unexpected start-up. To fulfil those requirements, additional external components are required according to appropriate standards and application requirements.
	In circumstances where external influences (e.g. falling of suspended loads) are present additional measures (e.g. mechanical brakes) may be necessary to prevent any hazard.
	STO shall not be used as a control for starting or stopping the drive.

9.3 STANDARDS

The STO function has been designed for use in accordance with the following standards:

Standards
IEC 61508, Parts 1-7
IEC 61800-5-2
IEC 62061
ISO 13849-1
IEC 60204-1

Table 51. Safety Standards.

The STO function has to be applied correctly to achieve the desired level of operational safety. Four different levels are allowed, depending on the use of the STO signals (see the following table).

STO inputs	STO feedback	Cat.	PL	SIL
Both dynamically used(*)	Used	4	e	3
Both statically used	Used	3	e	3
Connected in parallel	Used	2	d	2
Connected in parallel	Not used	1	c	1

Table 52. Four different STO levels. (*) see 9.5.1.

The same values are calculated for SIL and SIL CL. According to EN 60204-1, the emergency stop category is 0.

The SIL value for the safety related system, operating in high demand/continuous mode, is related to the probability of dangerous failure per hour (PFH), reported in the following table.

STO inputs	STO feedback	PFH	PFDav	MTTFd (years)	DCavg
Both dynamically used(*)	Used	8.0 E-10 1/h	7.0 E-05	8314 y	HIGH
Both statically used	Used	8.1 E-10 1/h	7.1 E-05	8314 y	MEDIUM
Connected in parallel	Used	8.1 E-10 1/h	7.1 E-05	8314 y	MEDIUM
Connected in parallel	Not used	9.2 E-10 1/h	8.0 E-05	8314 y	NONE

Table 53. SIL values. (*) see 9.5.1.



The STO inputs must always be supplied by a safety device.

The power supply of the safety device may be external or taken from the drive (as long as this is compliant with the rating specified for terminal 6). See Chapter 5.1.2 for the standard I/O terminal description.

9.4 THE PRINCIPLE OF STO

The STO functionality, such as the technical principles and data (wiring examples and commissioning) will be described in this chapter.

In VACON® 20 CP, the STO function is realized by preventing the propagation of the control signals to the inverter circuit.

The inverter power stage is disabled through redundant disabling paths which start from the two separated and galvanically isolated STO inputs (S1-G1, S2-G2 in Figure 50). In addition, an isolated output feedback is generated to improve the diagnostics of the STO function and to achieve a better safety capability (F+, F- terminals). The values assumed by the STO output feedback are indicated in the following table:

STO inputs	Operating conditions	STO feedback output	Torque at the motor shaft
Both inputs energized with 24V DC	Normal operation	The feedback must be 0V	present (motor on)
Power removed from both inputs	STO demand	The feedback must be 24V	disabled (motor de-energized)
The STO inputs have different values	Failure in demand or due to internal fault	The feedback must be 0V	disabled (motor de-energized)(*)

Table 54. Values of the STO output feedback (and torque on the motor). (*) Only one channel is preventing the drive from moving.

The diagram below is a conceptual schematic diagram and is presented to illustrate the safety function with relevant safety components only shown.

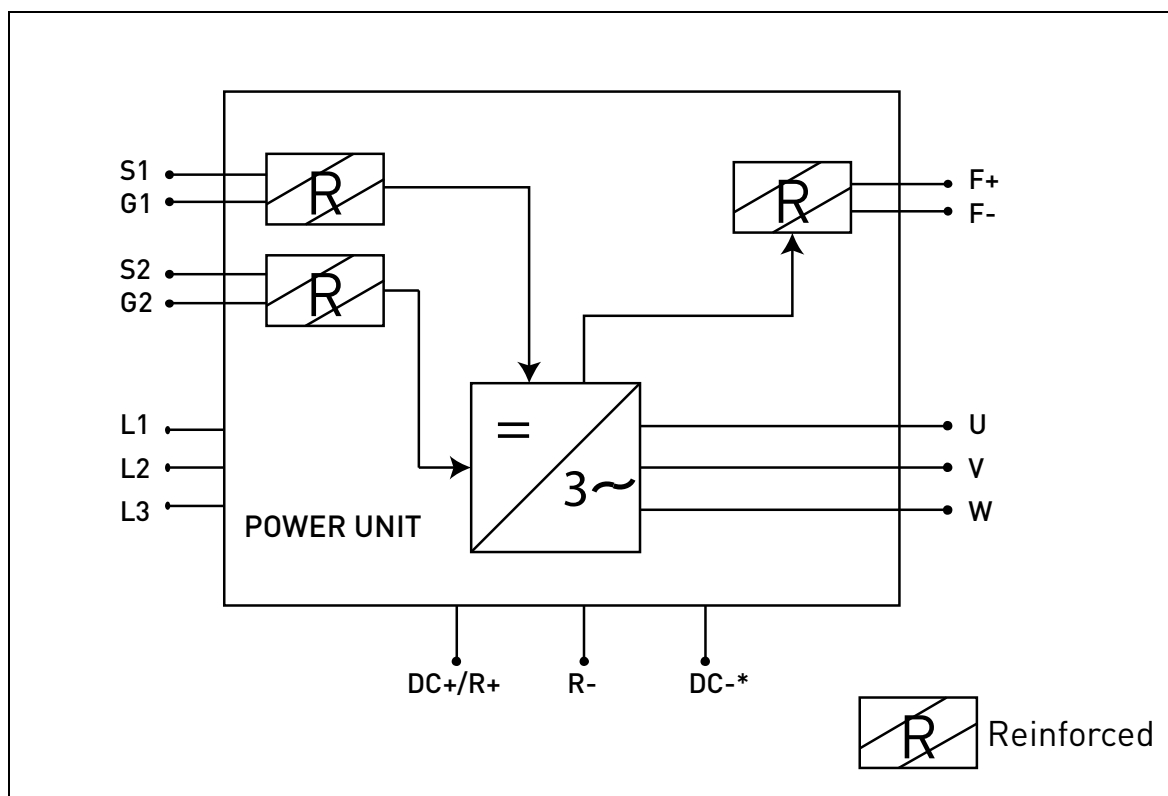

Figure 50. STO function principle. (*) Only for MS3.

9.4.1 TECHNICAL DETAILS

The STO inputs are digital inputs intended for a nominal 24V d.c. input, positive logic (e.g. enabled when high).

Technical information:	Technical values
Maximum voltage range	30V
Typical input current at 24V	10...15 mA
Logic threshold	according to IEC 61131-2 15V...30V = "1" 0V...5V = "0"
Response time at nominal voltage:	
Reaction time	<20ms

Table 55. Electrical data.

The reaction time of the STO function is the amount of time which passes from the moment in which the STO is demanded until the system is in the Safe State. For VACON® 20 CP, the reaction time is 20 ms maximum.

9.5 CONNECTIONS

To make the STO function available and ready to be used, both the STO jumpers have to be removed. They have been located in front of the STO terminal to mechanically prevent the insertion of the STO inputs. For the correct configuration, see the following table and the Figure 51.

Signal	Terminal	Technical information	Data
STO1	S1	Insulated digital input 1 (interchangeable polarity)	24V ±20% 10...15 mA
	G1		
STO 2	S2	Insulated digital input 2 (interchangeable polarity)	24V ±20% 10...15 mA
	G2		
STO feedback	F+	Insulated digital output for STO feedback (CAUTION! Polarity must be respected)	24V ±20% 15 mA max.
	F-		GND

Table 56. STO connector and data signals.

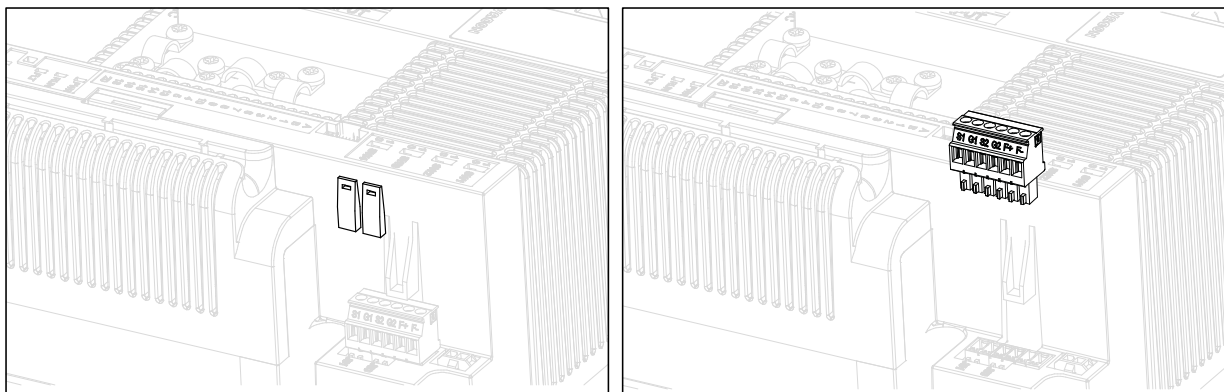

Figure 51. Removing the STO jumpers.

	Make sure that the AC drive is switched off before cabling.
	When the STO function is used, the drive has to be mounted in an enclosure which fulfils the requirements for IP54 .
	Disconnect both the STO jumpers to allow the cabling of the terminals.

The following examples show the basic principles for wiring the STO inputs and the STO output feedback. Local standards and regulations should be always followed in the final design.

9.5.1 SAFETY CAPABILITY CAT. 4 / PL e / SIL 3

For this safety capability, an external safety device must be installed. This must be used to dynamically activate the STO inputs and to monitor the STO output feedback.

The STO inputs are dynamically used when they do not commute together (static use), but according to the following picture (where the inputs are released with delay in turn). The dynamic use of the STO inputs allows detecting faults that may otherwise accumulate.

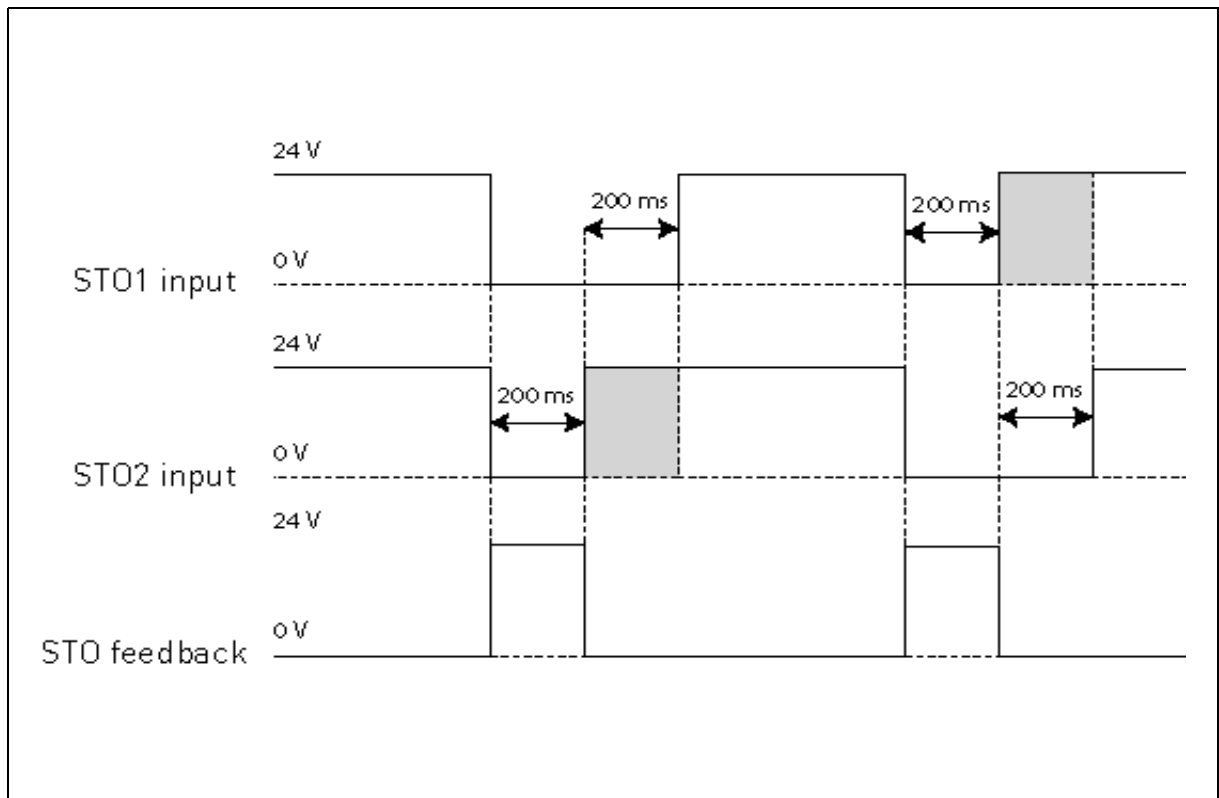

	<p>An emergency push button connected to the STO inputs does not assure the same quality, because no fault detection is performed at a sufficient proof test interval (once a day is recommended).</p>
	<p>The external safety device, which forces the STO inputs and evaluates the STO output feedback, has to be a safe device and it has to fulfil the requirements of the specific application.</p>
	<p>A simple switch cannot be used in this case!</p>

The picture below shows an example of connection for the STO function. The external device has to be connected with 6 wires to the drive.

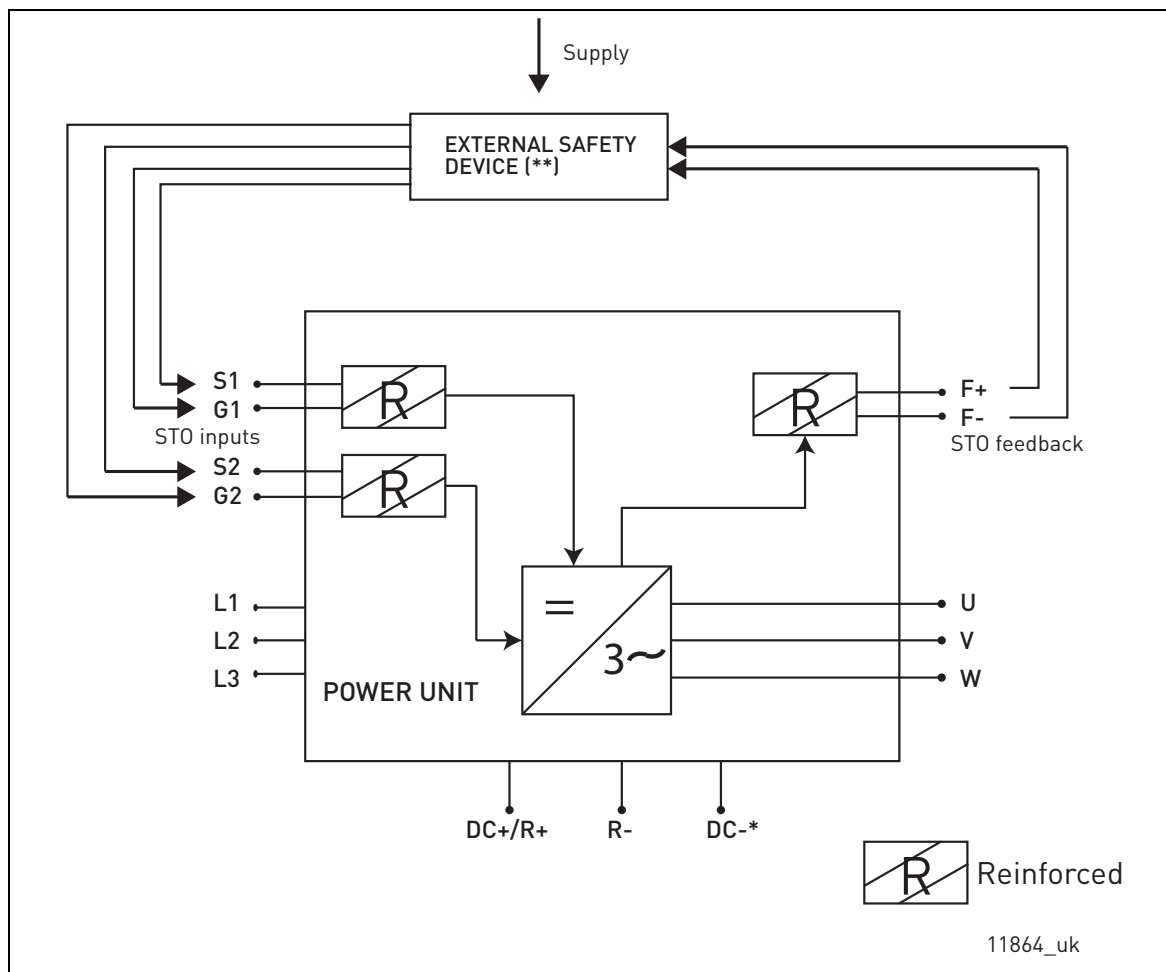

Figure 53. STO example with automatic monitoring of the feedback and both STO inputs used. (*) Only for MS3. (**) The external safety device must feed active voltage to the STO inputs.

The external device has to monitor the STO function in accordance with the Table 54. The device has to periodically de-energize the STO inputs and it has to verify that the STO output feedback assumes the expected value.

Any difference between the expected and the real value has to be considered as a failure and has to drive the system into a Safe State. In case of failure, check the wiring. If the fault recognized by the external safety device persists, **the drive will have to be replaced/repared.**

9.5.2 SAFETY CAPABILITY CAT. 3 / PL e / SIL 3

The safety capability is reduced to Cat. 3 / PL e / SIL 3 if the STO inputs are statically used (which means they are forced to commute together).

Both STO inputs and the STO feedback have to be used. The same warnings and cabling instruction as 9.5.1 apply, except that the proof test interval has to be at least once every three months.

9.5.3 SAFETY CAPABILITY CAT. 2 / PL d / SIL 2

The safety capability is reduced to Cat. 2 / PL d / SIL 2 if the STO inputs are connected in parallel (no redundancy of the STO inputs).

The STO feedback has to be used. The same warnings as 9.5.1 apply, except that the proof test interval has to be at least once a year. The picture below shows an example of connection for the STO function. The external device has to be connected with 4 wires to the drive.

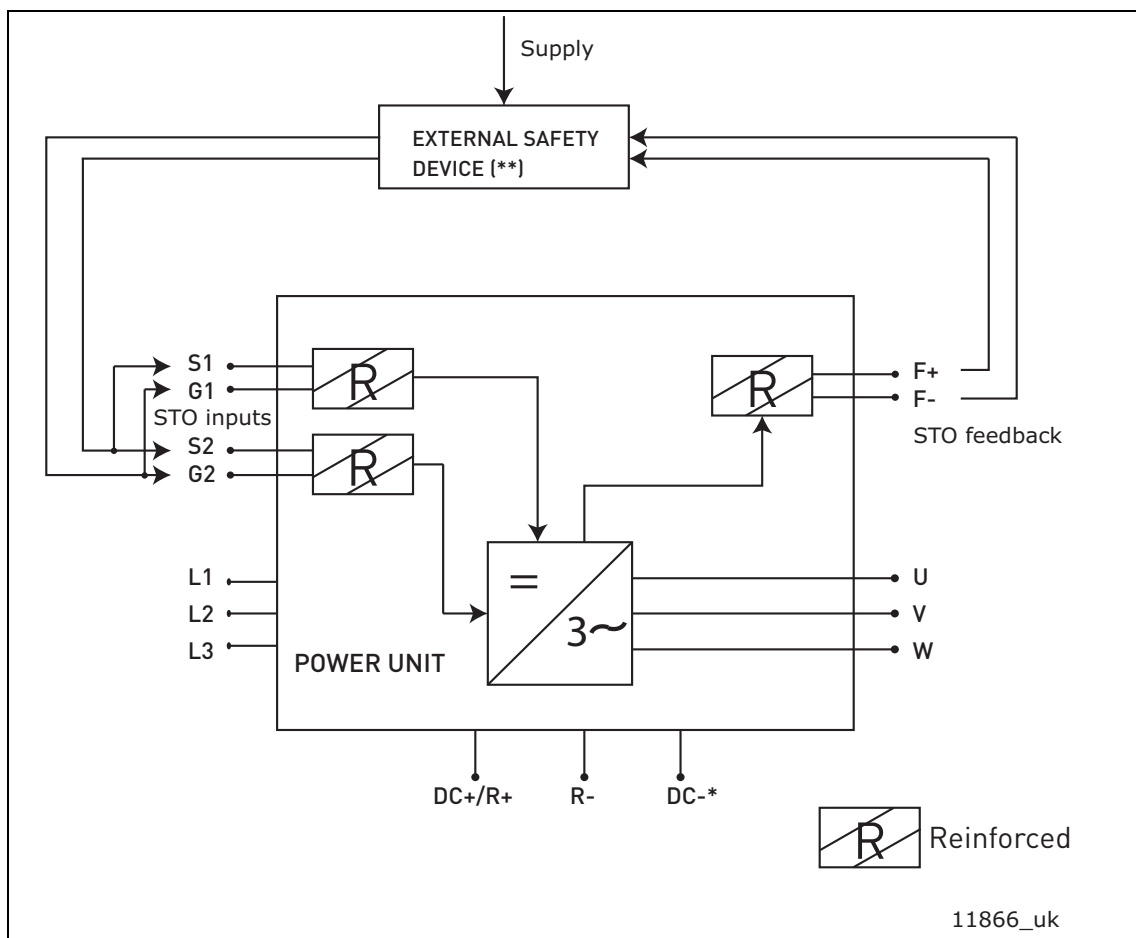





Figure 54. STO Example with automatic monitoring of the feedback and STO inputs connected in parallel. (*) Only for MS3. (**) The external safety device must feed active voltage to the STO inputs.

9.5.4 SAFETY CAPABILITY CAT. 1 / PL c / SIL 1

Without any automatic monitoring of STO output feedback, the safety capability is reduced to Cat. 1 / PL c / SIL 1. The STO inputs (which can be connected in parallel) must be supplied by a safety push button or a safety relay.

	The choice of using the STO inputs (without the automatic monitoring of the output feedback) does not allow the other safety capabilities to be achieved .
	The standards for functional safety require that functional proof tests are performed on the equipment at user-defined intervals. Therefore, this safety capability can be achieved, as long as the STO function is manually monitored at the proof test interval determined by the specific application (once a year can be acceptable).
	This safety capability can be achieved by connecting in parallel the STO inputs externally and by ignoring the use of the STO output feedback.

The picture below shows an example of connection for the STO function. A switch (a safety push button or a safety relay) may be connected with 2 wires to the drive.

When the contacts of the switch are opened, the STO is demanded, the drive indicates F30 (= "Safe Torque Off") and the motor stops by coasting.

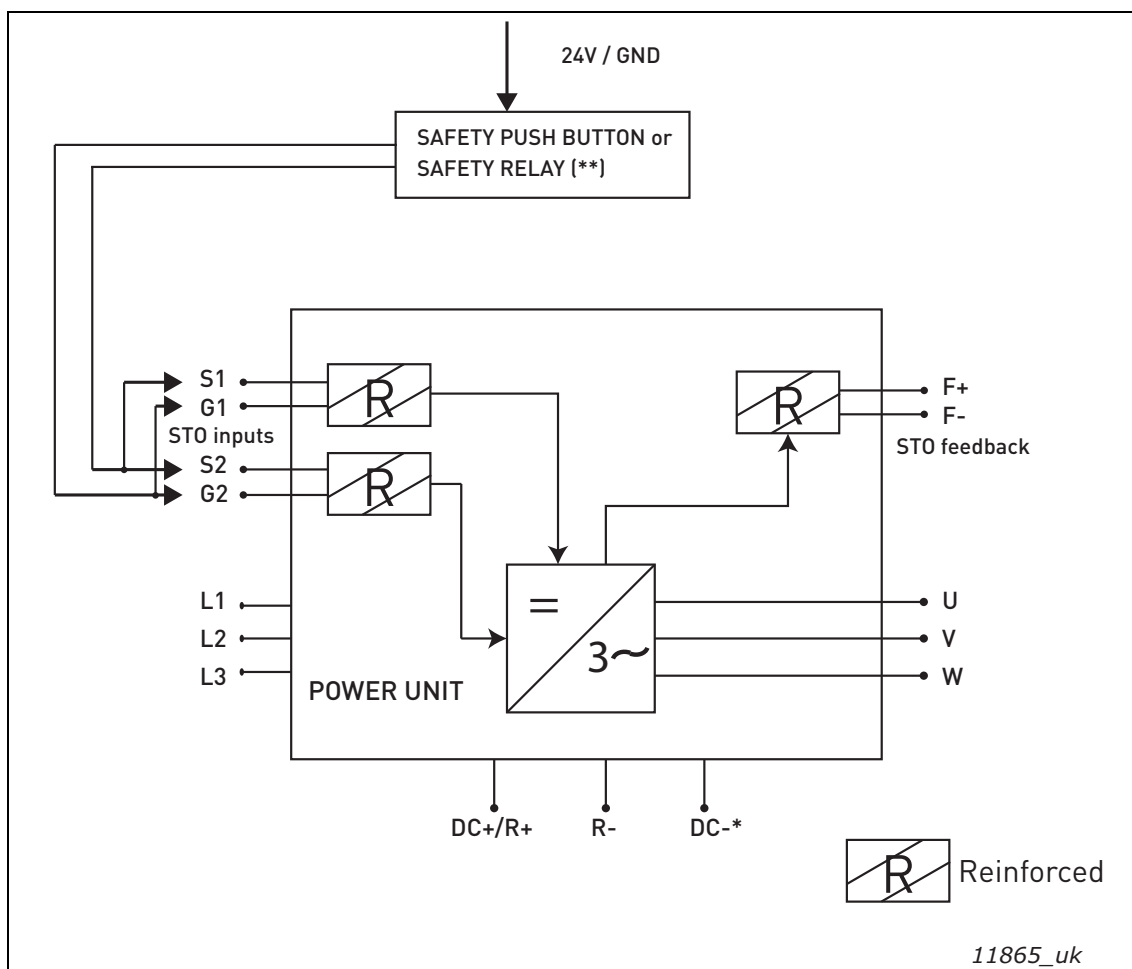



Figure 55. STO example without automatic monitoring of the feedback and STO inputs connected in parallel. (*)Only for MS3. (**) The safety push button or safety relay must feed active voltage to the STO inputs.

9.6 COMMISSIONING

9.6.1 GENERAL WIRING INSTRUCTIONS

	Protect the STO cabling with shielding or an enclosure to exclude external damage.
	Wire ferrules are highly recommended for all STO signals (inputs and feedback).

The wiring should be done according to the general wiring instructions for the specific product. A shielded cable is required. In addition, the voltage drop from the supply point to the load shall not exceed 5% [EN 60204-1 part 12.5].

The following table indicates examples of cables to be used.

STO feedback	Cable size
STO feedback automatically monitored by an external safety device	3 x (2 + 1) x 0,5 mm ² (*)
STO feedback ignored, simply safety device (switch) used	2 x (2 + 1) x 0,5 mm ²

Table 57. Cable types required to meet the standards. (*) Additional wires are needed for restarting the drive after each STO demand.

9.6.2 CHECKLIST FOR COMMISSIONING

Follow the checklist shown in the table below for the steps required to use the STO function.

<input type="checkbox"/>	Carry out a risk assessment of the system to ensure that the use of the STO function is safe and according to the local regulations
<input type="checkbox"/>	Include in the assessment an examination of whether the use of external devices, such as a mechanical brake, are required.
<input type="checkbox"/>	Check if the switch (if used) has been chosen according to the required safety performance target (SIL/PL/Category) set during the risk evaluation
<input type="checkbox"/>	Check if the external device for automatic monitoring of the STO output feedback (if used) has been chosen in accordance with the specific application
<input type="checkbox"/>	Check if the reset function with the STO function (if used) is edge sensitive.
<input type="checkbox"/>	The shaft of a permanent magnet motor might, in an IGBT fault situation, still provide energy before the torque production ceases. This may result in a jerk of max. 180° electrically. Ensure that the system is designed in such a way that this can be accepted.
<input type="checkbox"/>	Check if the degree of protection of the enclosure is at least IP54.
<input type="checkbox"/>	Check if the recommendations on EMC for cables have been followed.
<input type="checkbox"/>	Check if the system has been designed in such a way that enabling of the drive through STO inputs will not lead to an unexpected start of the drive



Table 58. Checklist for commissioning of STO.

<input type="checkbox"/>	Check if only approved units and parts have been used.
<input type="checkbox"/>	Set up a routine to ensure that the functionality of the STO function is being checked at regular intervals.

Table 58. Checklist for commissioning of STO.

9.7 PARAMETERS AND FAULT TRACING



There are no parameters for the STO function itself.

	Before testing the STO function, make sure that the checklist (Table 58) is inspected and completed.
	When STO function is demanded, the drive always generates a fault ("F30") and the motor stops by coasting.
	In the application the STO state can be indicated using a digital output.

To re-enable motor operation, after the STO state, it is necessary to perform the following steps:

- Release the switch or the external device ("F30" is displayed even after this has been released).
- Reset the fault (through a digital input or from the keypad).
- It is possible that a new start command is required for the restart (depending on the application and your parameter settings).

9.8 MAINTENANCE AND DIAGNOSTICS

	If any service or repair has to be conducted on the drive installed, please inspect the checklist given in Table 58.
	During maintenance breaks, or in case of service/repair, ALWAYS make sure that the STO function is available and fully functional by testing it.

The STO function or the STO input/output terminals do not need any maintenance.

The following table shows faults that may be generated by the software that monitors the hardware related to the STO safety function. If you detect any failure in safety functions, including STO, contact your local distributor.

Fault Code	Fault	Cause	Correction
30	STO fault	STO inputs in a different state or both de-energized	Check cabling

Table 59. Fault related to the STO function.

NOTE! See Table 49 for detailed fault code descriptions.

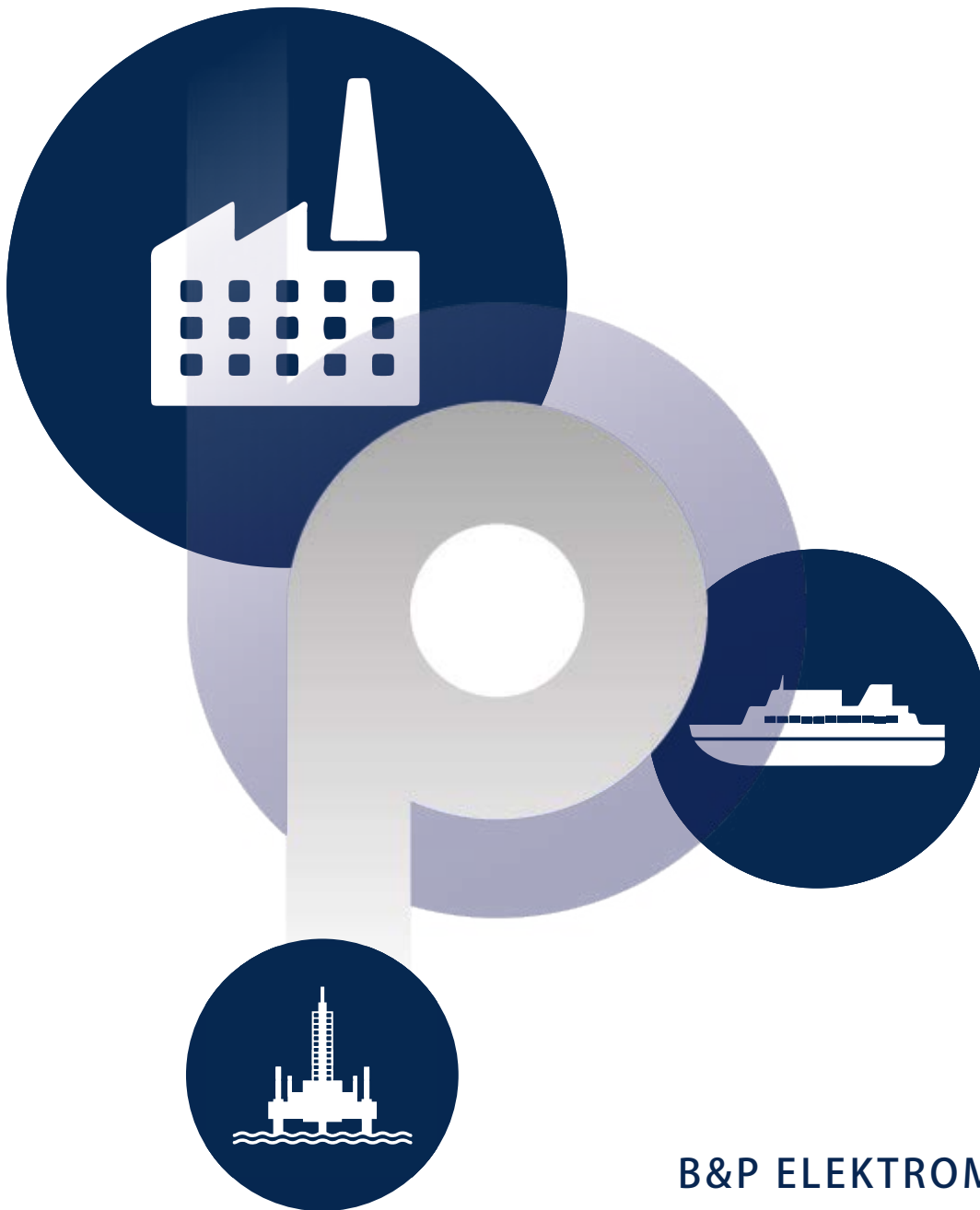

B&P ELEKTROMOTOREN BV

Ampèrestraat 8F
4004 KB Tiel

info@bnpelektromotoren.nl

+31 (0)344 616 267

BTW nr. NL819113918B01

KvK nr. 30237800

ING Bank NL60 INGB 0675 304 792



www.bnpelektromotoren.nl